



**NEW HOLLAND**



# **TD60 – TD70 – TD80 – TD90 – TD95 STRADDLE MOUNT MODEL TRACTORS SERVICE MANUAL**

<b>SECTIONS</b>	
<b>GENERAL</b> .....	<b>00</b>
<b>ENGINE</b> .....	<b>10</b>
<b>CLUTCH</b> .....	<b>18</b>
<b>GEARBOX</b> .....	<b>21</b>
<b>TRANSMISSION OF MOTION</b> .....	<b>23</b>
<b>FRONT MECHANICAL TRANSMISSION</b> .....	<b>25</b>
<b>REAR MECHANICAL TRANSMISSION</b> .....	<b>27</b>
<b>POWER TAKE-OFF</b> .....	<b>31</b>
<b>BRAKES</b> .....	<b>33</b>
<b>HYDRAULIC SYSTEMS</b> .....	<b>35</b>
<b>STEERING</b> .....	<b>41</b>
<b>AXLE AND WHEELS</b> .....	<b>44</b>
<b>ELECTRICAL SYSTEM</b> .....	<b>55</b>
<b>CAB</b> .....	<b>90</b>

**S E R V I C E**

## INTRODUCTION

- ◇ *This manual is divided into sections identified by two-figure numbers. Each section has independent page numbering.  
For ease of reference, these sections have the same numbers and names as the Repairs Rate Book sections.*
- ◇ *The different sections can easily be found by consulting the table of contents on the following pages.*
- ◇ *The document number of the manual and the edition/update dates are given at the bottom of each page.*
- ◇ *Pages updated in the future will be identified by the same document number followed by a two-figure update number (for example: 1st update 603.54.331.01; 2nd update 603.54.331.02; etc.) and the corresponding issue date.  
These pages will be supplemented by a reprint of the updated contents page.*
- ◇ *The information contained in this manual was current on the date printed on each section. As NEW HOLLAND constantly improves its product range, some information may be out of date subsequent to modifications implemented for technical or commercial reasons or to meet legal requirements in different countries.  
In the event of conflicting information, consult the NEW HOLLAND Sales and Service Departments.*

## IMPORTANT WARNINGS

- ◇ *All maintenance and repair work described in this manual must be performed exclusively by NEW HOLLAND service technicians in strict accordance with the instructions given and using any specific tools necessary.*
- ◇ *Anyone who performs the operations described herein without strictly following the instructions is personally responsible for resulting injury or damage to property.*
- ◇ *The Manufacturer and all organisations belonging to the Manufacturer's distribution network, including but not restricted to national, regional or local distributors, will accept no responsibility for personal injury or damage to property caused by abnormal function of parts and/or components not approved by the Manufacturer, including those used for maintenance and/or repair of the product manufactured or marketed by the Manufacturer.  
In any case, the product manufactured or marketed by the Manufacturer is covered by no guarantee of any kind against personal injury or damage to property caused by abnormal function of parts and/or components not approved by the Manufacturer.*

TEXT AND ILLUSTRATIONS ARE THE PROPERTY  
OF NEW HOLLAND ??????????????????



No part of the text or illustrations  
may be reproduced

PRINTED IN ??????

**NEW HOLLAND ?????????? – ???**  
SERVICE – Technical Publications & Special Tools  
Print no. ????.???.????.?? – 06 – 2002

# NEW HOLLAND

## Repair Manual–TD Straddle Mount Series Tractors

---

### CONTENTS

#### GENERAL

#### SECTION 00

##### General Instructions and Health and Safety

##### Chapter 1

Section	Description	Page
00 000	General instructions .....	1
	Notes for spare parts .....	2
	Notes for equipment .....	2
	Safety rules .....	3
	Consumables .....	6

#### ENGINE

#### SECTION 10

##### Engine System

##### Chapter 1

Section	Description	Page
10 000	General specifications .....	2
	Data .....	5
	Torque settings .....	24
	Tools .....	25
	Cross-sectional views .....	28
	Lubrication and cooling system diagrams .....	32
	Troubleshooting .....	35
10 001	Removal – Installation – Overhaul .....	39
	Checks, dimensions and repairs .....	80

#### CLUTCH

#### SECTION 18

##### Clutches

##### Chapter 1

Section	Description	Page
18 000	General Characteristics .....	1
	Tightening Torques .....	2
	Tools .....	3
	Sectional views .....	3–6
	Clutch Troubleshooting .....	7
18 110 10	Removal – Refitting .....	8–15
18 110 30	Overhaul .....	16–19

**<https://www.ebooklibonline.com>**

Hello dear friend!

Thank you very much for reading.

Enter the link into your browser.

The full manual is available for immediate download.

**<https://www.ebooklibonline.com>**

	Checks, measurements and repairs .....	20–21
<b>18 100 40</b>	Adjustments .....	22–23

## GEARBOX

## SECTION 21

### Mechanical Transmission (12x4)

### Chapter 1

Section	Description	Page
<b>21 000</b>	Main data .....	1
	Tightening torques .....	2
	Tools .....	3
	Section views .....	5
	Description and operation .....	8
	Fault diagnosis .....	8
<b>21 110</b>	Removal – Refitting .....	see sect 27

### Reverser (12x12)

### Chapter 2

Section	Description	Page
<b>21 000</b>	Main data .....	1
	Tightening torques .....	2
	Tools .....	3
	Section views .....	3
	Description and operation .....	5
	Fault diagnosis .....	5
<b>21 110</b>	Removal–Refitting .....	6

### Reverser and Creeper (20x12)

### Chapter 3

Section	Description	Page
<b>21 000</b>	Main data .....	1
	Tightening torques .....	2
	Tools .....	3
	Section views .....	4
	Description and operation .....	6
	Fault diagnosis .....	6
<b>21 110</b>	Removal–Refitting .....	7

## DRIVE LINES

## SECTION 23

### Drive Lines

### Chapter 1

Section	Description	Page
<b>23 000</b>	Main specification .....	1
	Torque settings and Tools .....	2
	Cross–Sectional views .....	3
<b>23 101 26</b>	Transmission shafts and guard (Disassembly – Assembly) .....	4
<b>23 101 40</b>	Drive gear housing (Removal – Installation) .....	5–6
<b>23 101 42</b>	Drive gear housing removed (Disassembly – Assembly) .....	7

## FRONT AXLE MECHANICAL TRANSMISSION

## SECTION 25

### Front Axle Mechanical Transmission

### Chapter 1

Section	Description	Page
25 000	Main data .....	1
	Tightening torques .....	4
	Tools .....	6
	Cross-sectional views .....	7
	Description and operation .....	9
	25 100 30	Complete front axle. Removal – Installation .....
25 100 38	Front axle. Removal – Installation .....	14
25 108 46–47	Steering knuckle bearing pins. Replacement .....	24
	Stub axle adjustment .....	25
	Wheel hub bearing adjustment .....	27
	Bevel drive adjustment .....	28
25 102 24	Front axle differential. Overhaul .....	34
25 100 27	Front axle differential with LIM–SLIP. Overhaul .....	35
	Front axle differential with NO SPIN. Overhaul .....	37
44 511 80	Leading drive wheels toe-in check .....	40

## REAR AXLE AND TRANSMISSION

## SECTION 27

### Rear Axle And Transmission

### Chapter 1

Section	Description	Page
27 000	Main specification .....	1
	Torque settings .....	3
	Special tools .....	5
	Sectional views .....	6
	Description and operation .....	7
	Fault finding .....	8
27 100	Removal–Refitting–Overhaul .....	9

## POWER TAKE-OFF

## SECTION 31

### Mechanical Power Take – Off

### Chapter 1

Section	Description	Page
31 000	Main specifications .....	1
	Tools .....	3
	Torque settings .....	4
	Sectional drawings .....	5
	Description and operation .....	8
	Troubleshooting .....	9
	Removal – Refitting .....	10
31 101	Bench overhaul .....	13

## BRAKING SYSTEM

## SECTION 33

### Braking System

### Chapter 1

Section	Description	Page
31 000	Main specifications .....	1
	Tools .....	2
	Torque settings .....	3
	Sectional drawings .....	5
	Description and operation .....	6
	Troubleshooting .....	7
	Removal – Refitting .....	7
31 101	Bench overhaul .....	12

## HYDRAULIC SYSTEM

## SECTION 35

### Rear Mechanical Hydraulic Lift

### Chapter 1

Section	Description	Page
35 000	Main specification .....	1
	Torque settings .....	5
	Tools .....	6
	Sectional views .....	7
	Description and operation .....	9
	Fault diagnosis .....	13
35 114	Removal – Refitting – Overhaul .....	15

### Open Centre System Auxiliary Control Valves

### Chapter 2

Section	Description	Page
35 000	Main data – Tools .....	1
	Sectional views .....	2
	Description and operation .....	3
	Fault diagnosis .....	see 'lift' in chapter 1
35 204	Overhaul .....	6

### Trailer Brake Auxiliary Control Valve

### Chapter 3

Section	Description	Page
35 000	Section views .....	1
	Description and operation .....	1
	Trailer brake remote control valve linkage adjustment .....	6

## STEERING

## SECTION 41

### Steering

### Chapter 1

Section	Description	Page
41 000	Principal data .....	1
	Torque settings .....	3
	Operation .....	7
	Fault diagnosis .....	9
	Tools .....	10
41 204	Hydrostatic steering control valve – Removal–Refitting .....	11
	Hydrostatic steering control valve – Disassembly–Assembly .....	14

	Hydrostatic steering control valve – Bench testing .....	28
41 206	Hydrostatic steering oil pump – Disassembly–Assembly .....	30
41 216	Steering cylinder – Removal–Refitting .....	32

## FRONT AXLE AND WHEELS

## SECTION 44

### Front Axle And Wheels

### Chapter 1

Section	Description	Page
44 000	Principal data .....	1
	Sectional views .....	3
	Torque settings .....	4
	Equipment – Fault diagnosis .....	5
44 101	Removal–Refitting–Overhaul .....	6
44 101	Wheel hub disassembly–assembly .....	9
44 101	Stub axle overhaul .....	12

## ELECTRICAL SYSTEM

## SECTION 55

### Instruments

### Chapter 1

Section	Description .....	Page
55 418	Analogue instruments .....	1
	Introduction .....	1
	Maintenance .....	14

### Components

### Chapter 2

Section	Description .....	Page
55 500	Introduction .....	1
	Component description .....	2

### Starting System

### Chapter 3

Section	Description .....	Page
55 000	Technical information .....	1
	Tightening torques .....	1
	Description and operation .....	2
	Trouble–shooting .....	4
	System tests .....	5
55 201	Removal and re–installation of starter motor .....	7
	Servicing .....	8
	Bench tests .....	10

### Charging System

### Chapter 4

Section	Description .....	Page
55 000	Technical information .....	1
	Tightening torques .....	1
	Description and operation .....	2
	System testing and trouble–shooting .....	4
55 301	Removal, re–installation and servicing .....	10

### Battery

### Chapter 5

<b>Section</b>	<b>Description</b> .....	<b>Page</b>
<b>55 000</b>	Technical information .....	1
	Description and operation .....	1
<b>55 301</b>	Removal and re-installation .....	2
	Battery checking and maintenance .....	3
	Charging the battery .....	4
	Battery problems – Frequent causes .....	7

## **Electrical Circuits**

## **Chapter 6**

<b>Section</b>	<b>Description</b> .....	<b>Page</b>
<b>55 100</b>	Fuses (all versions) .....	2
	Symbols used in electrical circuits .....	3
	Electrical wire colour coding .....	4
	Electrical diagrams	
	General diagrams .....	5
	Start-up circuit .....	6
	Side lights, main and dipped headlights, parking light circuit .....	7
	Direction indicator and hazard warning light circuit .....	8
	Work lamp circuit .....	9
	Windscreen and rear window wiper/washer circuit .....	10
	Heating and air-conditioning system circuit .....	11
	Analogue instrument circuit .....	12

## **BODYWORK AND DRIVER POSITION**

## **SECTION 90**

### **Bodywork And Driver Position**

### **Chapter 1**

<b>Section</b>	<b>Description</b> .....	<b>Page</b>
<b>90 000</b>	Disassembly–Assembly .....	1

## GENERAL INSTRUCTIONS

### IMPORTANT NOTICE

All maintenance and repair operations described in this manual should be carried out exclusively by the FIATA-GRI authorised workshops. All instructions detailed should be carefully observed and special equipment indicated should be used if necessary.

Everyone who carries out service operations described without carefully observing these prescriptions will be directly responsible of deriving damages.

### SHIMMING

At each adjustment, select adjusting shims, measure them individually using a micrometer and then sum up recorded values. Do not rely on measuring the whole shimming set, which may be incorrect, or on rated value indicated for each shim.

### ROTATING SHAFT SEALS

To correctly install rotating shaft seals, observe the following instructions:

- Let the seal soak into the same oil as it will seal for at least half an hour before mounting;
- Thoroughly clean the shaft and ensure that the shaft working surface is not damaged;
- Place the sealing lip towards the fluid. In case of a hydrodynamic lip, consider the shaft rotation direction and orient grooves in order that they deviate the fluid towards the inner side of the seal;
- Coat the sealing lip with a thin layer of lubricant (oil rather than grease) and fill with grease the gap between the sealing lip and the dust lip of double lip seals;
- Insert the seal into its seat and press it down using a flat punch. Do not tap the seal with a hammer or a drift;
- Take care to insert the seal perpendicularly to its seat while you are pressing it. Once the seal is settled, ensure that it contacts the thrust element if required.;
- To prevent damaging the sealing lip against the shaft, place a suitable protection during installation.

### O RINGS

Lubricate the O rings before inserting them into their seats. This will prevent the O rings from rolling over and twine during mounting which will jeopardise sealing.

### SEALERS

Apply one of the following sealers: RTV SILMATE, RHODORSIL CAF 1, or LOCTITE PLASTIC GASKET over the mating surfaces marked with an X.

Before applying the sealer, prepare the surface as follows:

- remove possible scales using a metal brush;
- thoroughly degrease the surfaces using one of the following cleaning agent: trichlorethylene, petrol or a water and soda solution.

### BEARINGS

It is advisable to heat the bearings to 80 to 90°C before mounting them on their shafts and cool them down before inserting them into their seats with external tapping.

### ROLL PINS

When fitting straight roll pins, ensure that the pin notch is oriented in the direction of the effort to stress the pin. Coil roll pins can be installed in any position.

**SECTION 10 – ENGINE****Chapter 1 – Engine****CONTENTS**

<b>Section</b>	<b>Description</b>	<b>Page</b>
<b>10 000</b>	General specification .....	2
	Data .....	5
	Tightening torques .....	24
	Tools .....	25
	Cross-sectional views .....	28
	Lubrication and cooling system diagrams .....	32
	Fault diagnosis .....	35
<b>10 001</b>	Removal – Installation – Overhaul .....	39
	Checks, dimensions and repairs .....	80

GENERAL SPECIFICATION	3-cylinder	4-cylinder
<b>Engine type:</b>		
– TD 60 model normally aspirated – type 8035.05D.639/939 (BOSCH pump) .....	–	–
– TD 70 model turbocharged – type 8035.25C.639/939 (BOSCH pump) .....	–	–
– TD 80 model normally aspirated – type 8045.05R.639/939 (BOSCH pump) .....	–	–
– TD 90 model turbocharged – type 8045.25.639/939 (BOSCH pump) .....	–	–
– TD 95 model turbocharged – type 8045.25L.639/939 (BOSCH pump) .....	–	–
Cycle .....	Diesel, 4–stroke	
Fuel injection .....	Direct	
Number of cylinders in line .....	3	4
Cylinder liners .....	dry force–fitted in cylinder block	dry force–fitted in cylinder block
<b>Piston diameter</b>		
– TD 60 model .....	104 mm	–
– TD 70 model .....	104 mm	–
– TD 80 model .....	–	104 mm
– TD 90 model .....	–	104 mm
– TD 95 model .....	–	104 mm
Piston stroke .....	115 mm	
<b>Total displacement:</b>		
– TD 60 model .....	2931 cm <sup>3</sup>	–
– TD 70 model .....	2931 cm <sup>3</sup>	–
– TD 80 model .....	–	3908 cm <sup>3</sup>
– TD 90 model .....	–	3908 cm <sup>3</sup>
– TD 95 model .....	–	3908 cm <sup>3</sup>
Compression ratio .....	17 to 1 normally aspirated 16.5 to 1 turbocharged	
<b>Maximum power 2000/25 EC at 2500 rpm:</b>		
– TD 60 model .....	43.4 kW (59 HP)	–
– TD 70 model .....	50.7 kW (69 HP)	–
– TD 80 model .....	–	58.8 kW (80 HP)
– TD 90 model .....	–	65.5 kW (89 HP)
– TD 95 model .....	–	69.1 kW (94 HP)
<b>Maximum power ECE R 24 at 2500 rpm:</b>		
– TD 60 model .....	41.2 kW (56 HP)	–
– TD 70 model .....	47.8 kW (65 HP)	–
– TD 80 model .....	–	55.9 kW (76 HP)
– TD 90 model .....	–	63.3 kW (86 HP)
– TD 95 model .....	–	66.9 kW (91 HP)
Fast idling speed .....	2500 rev/min	
Maximum torque (daNm) at 1500 rpm: TD 60 model .....	20.7	–
Maximum torque (daNm) at 1500 rpm: TD 70 model .....	25.0	–
Maximum torque (daNm) at 1500 rpm: TD 80 model .....	–	27.9
Maximum torque (daNm) at 1500 rpm: TD 90 model .....	–	32.0
Maximum torque (daNm) at 1500 rpm: TD 95 model .....	–	33.7
Number of main bearings .....	4	5
Sump .....	Structural, cast iron	

(continued)

GENERAL SPECIFICATION	3-cylinder	4-cylinder
<b>Lubrication</b> ..... Pump drive ..... Engine speed/oil pump speed ratio ..... Oil cleaning ..... Normal oil pressure, with engine hot and at fast idling speed: . Lube pressure relief valve ..... Valve opening pressure ..... For further lubrication data .....	forced, with gear pump camshaft 2:1 mesh filter on oil intake and cartridge filter on delivery line 2.9 to 3.9 bar (3 to 4 kg/cm <sup>2</sup> ) built into pump housing 3.5 bar (3.6 kg/cm <sup>2</sup> ) See page 23	
<b>Cooling system</b> ..... Radiator on TD60, TD70, TD80 and TD90 models ..... Radiator on TD95 models ..... Fan, attached to coolant pump pulley ..... Coolant pump ..... Engine speed/coolant pump speed ratio ..... Temperature control ..... Coolant temperature gauge ..... Temperature ranges corresponding to each section: – initial white section ..... – middle green section ..... – final red section ..... For further cooling system data .....	coolant circulation 3-row vertical pipes with copper fins four-row vertical pipes with copper fins 4-blade steel exhauster fan 6-blade steel exhauster fan (TD95) centrifugal vane-type 1:1,403 Thermostat coloured scale divided into 3 sections from 30° to 65° C from 65° to 105° C from 105° to 115° C See page 23	
<b>Rev counter</b> ..... Rev counter drive ..... Hour counter calibrated for engine speed of .....	incorporated in control panel from gear on camshaft 1800 rev/min	

(continued)

(continued)

GENERAL SPECIFICATIONS	3-cylinder	4-cylinder
<b>Timing</b> .....  Intake: – start: before T.D.C ..... – end: after B.D.C ..... Exhaust: – start: before B.D.C ..... – end: after T.D.C ..... Valve clearance for timing check ..... Valve clearance for normal running (engine cold): – intake ..... – exhaust ..... For further timing data .....	overhead valves operated by a camshaft located in the engine block through tappets, pushrods and rockers. Camshaft is driven by the crankshaft through helical gears.  12° 31°  50° 16°  0.45 mm  0.30 ± 0.05 mm 0.30 ± 0.05 mm  See page 20	
<b>Fuel System</b> Air cleaning .....  Fuel pump .....  Fuel Filter .....  Minimum fuel flow rate with pump shaft rotating at 1600 rev/min. ....  Operated by eccentric cam .....  BOSCH injection pump .....  All-speed governor, incorporated in pump: BOSCH  Automatic advance regulator, incorporated in pump: BOSCH  For further fuel system data:  For fixed advance (pump setting for start of delivery before TDC) – Pressure setting – Injection order, and other information regarding the BOSCH pump	dual cartridge dry air filter with clogged filter indicator, centrifugal pre-filter and automatic dust ejector  double diaphragm  mesh filter in fuel supply pump and replaceable cartridge on delivery line to injection pump.  100 litres/hour  on camshaft  distributor type  centrifugal counterweights  hydraulic  see pages 5 to 15  refer to the data for the relevant engine type in the table on pages 5 to 15	

DATA

Turbocharger (TD95 Model): – . . . . . GARRETT type . . . . .		T25			
Fuel injection pump . . . . . BOSCH pump: – . . . . . TD 60 model . . . . . – . . . . . TD 70 model . . . . . – . . . . . TD 80 model . . . . . – . . . . . TD 90 model . . . . . – . . . . . TD 95 model . . . . . Direction of rotation . . . . . Injection order . . . . .		distributor type with incorporated speed governor and automatic advance regulator  VE 3/12 F 1250 L 976 VE 3/12 F 1150 L 977 VE 4/12 F 1250 L 980 VE 4/12 F 1250 L 982 VE 4/12 F 1150 L 972  anti-clockwise  1–2–3 (TD60 and TD70 Models) 1–3–4–2 (TD80, TD90 and TD95 Models)			
Fuel Injectors: BOSCH . . . . . – Nozzle holder type . . . . . – Nozzle type . . . . . Number of nozzles Diameter of nozzle orifices Pressure setting	5    248–272 bar		6    248–272 bar		
	TD70	TD95	TD60	TD80	TD90
Fuel delivery lines – BOSCH pump – Type . . . . . – Dimensions . . . . . mm	–	–	–	–	–

**ENGINE****Removal – Installation (Operation 10 001 10)****DANGER**

Lift and handle all heavy parts using suitable lifting equipment.

Make sure that assemblies or parts are supported by means of suitable slings and hooks.

Check that no one is in the vicinity of the load to be lifted.

**WARNING**

Always use suitable tools to align holes in parts.  
**NEVER USE FINGERS OR HANDS.**

1. Disconnect the battery negative cable.
2. Drain oil from the transmission/gearbox.
3. Drain the cooling system.

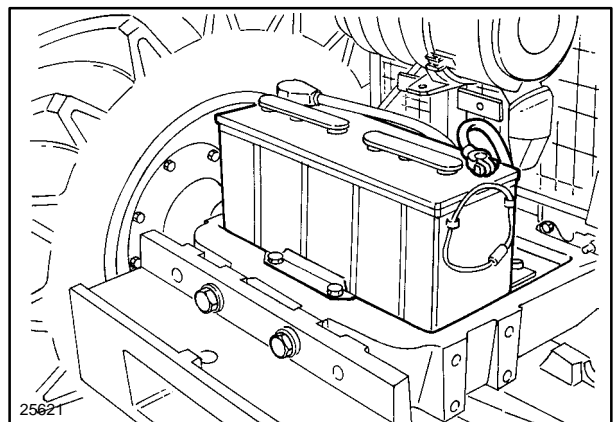

10

4. Unscrew the nut (1) from the weight retaining pin.

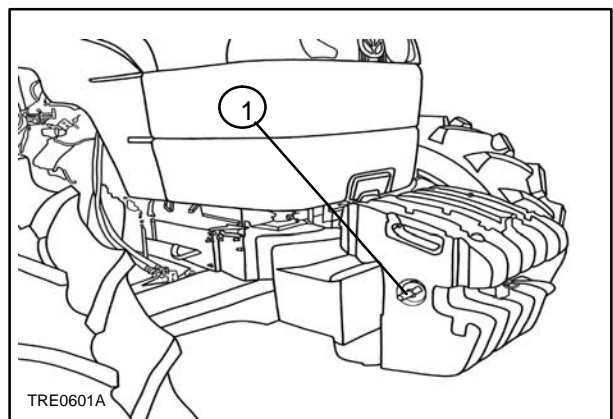

11

5. Remove the weights (1) from the front support.

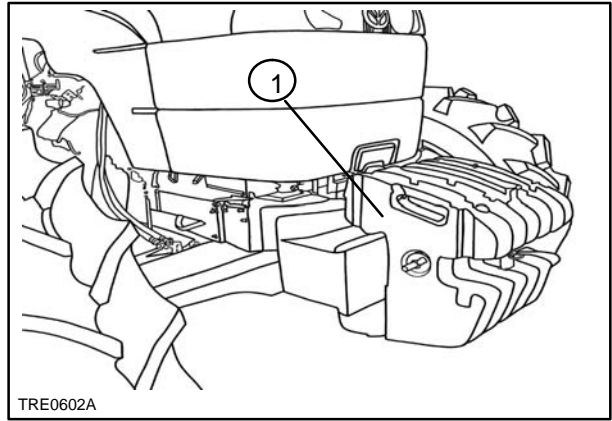

12

6. Remove the exhaust pipe, attach lifting chains to the bonnet (1) and attach the chain to the hoist.

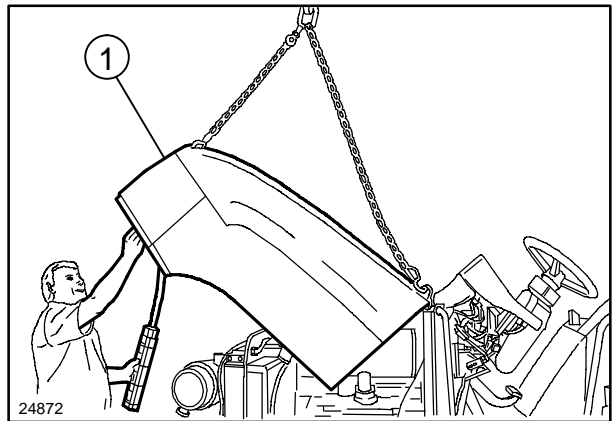

13

7. Disconnect the electrical leads (1) from headlamps (2).

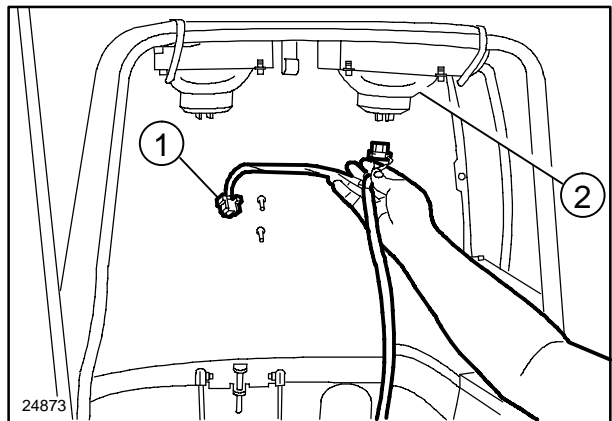

14

8. Detach the gas struts (1) from the bonnet.

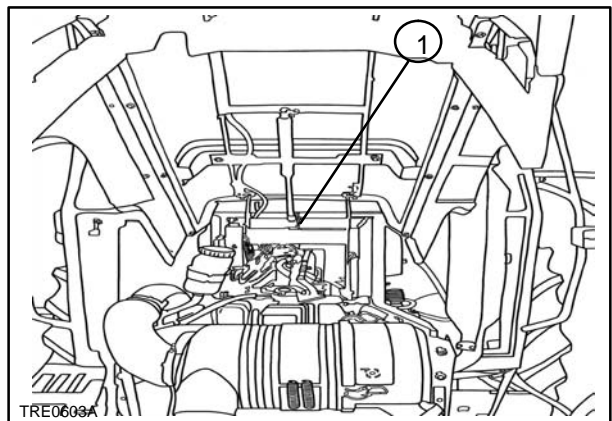

15



**Suggest:**

**If the above button click is invalid.**

**Please download this document**

**first, and then click the above link**

**to download the complete manual.**

**Thank you so much for reading**

9. Remove the four bonnet hinge bolts (1) and lift the bonnet clear.

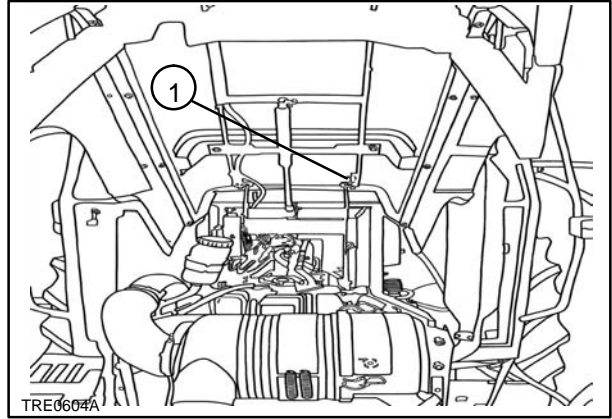

16

10. Remove the wire mesh guard (1) from right-hand side of the fan.

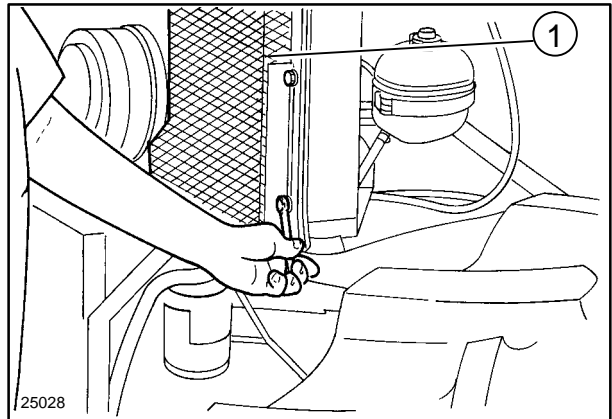

17

11. Disconnect the tachometer cable (1) and remove the retaining ring and sleeve.

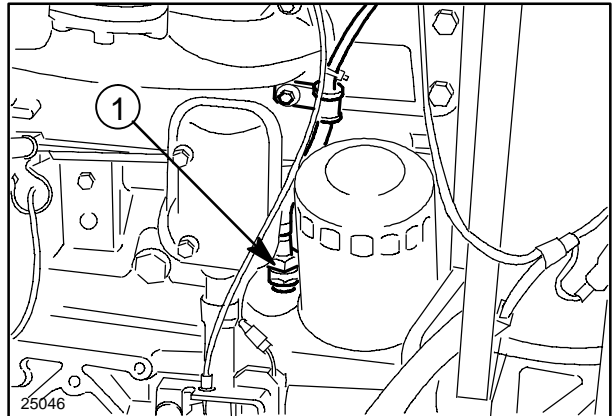

18

12. Detach the throttle control spring (1) and remove the throttle lever (2).

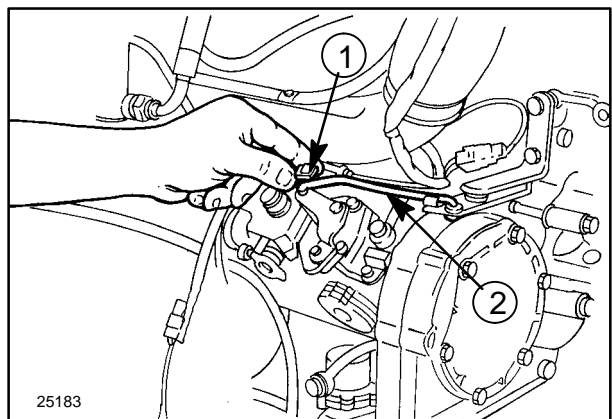

19

**<https://www.ebooklibonline.com>**

Hello dear friend!

Thank you very much for reading.

Enter the link into your browser.

The full manual is available for immediate download.

**<https://www.ebooklibonline.com>**