

# SERVICE MANUAL

**T7.230 / T7.245 / T7.260**

**T7.230 AutoCommand™ / T7.245 AutoCommand™**

**T7.260 AutoCommand™ / T7.270 AutoCommand™**

**Stage IV**

Tractor

Part number 47936454

English

November 2015





## **SERVICE MANUAL**

**T7.230 AutoCommand™, T7.230, T7.245 AutoCommand™, T7.245, T7.260  
AutoCommand™, T7.260, T7.270 AutoCommand™**

# Link Product / Engine

---

<b>Product</b>	<b>Market Product</b>	<b>Engine</b>
T7.230 AutoCommand™	Europe	F4DFE613K*B006
T7.245 AutoCommand™	Europe	F4DFE613J*B006
T7.260 AutoCommand™	Europe	F4DFE613H*B003
T7.270 AutoCommand™	Europe	F4DFE613B*B006
T7.230	Europe	F4DFE613K*B006
T7.245	Europe	F4DFE613J*B006
T7.260	Europe	F4DFE613H*B003

**<https://www.ebooklibonline.com>**

Hello dear friend!

Thank you very much for reading.

Enter the link into your browser.

The full manual is available for immediate download.

**<https://www.ebooklibonline.com>**

# Contents

---

## INTRODUCTION

<b>Engine</b> .....	<b>10</b>
[10.001] Engine and crankcase .....	10.1
[10.216] Fuel tanks .....	10.2
[10.218] Fuel injection system.....	10.3
[10.254] Intake and exhaust manifolds and muffler .....	10.4
[10.500] Selective Catalytic Reduction (SCR) exhaust treatment.....	10.5
[10.400] Engine cooling system .....	10.6
[10.414] Fan and drive .....	10.7
[10.408] Oil cooler and lines.....	10.8
[10.101] Cylinder heads .....	10.9
<b>Clutch</b> .....	<b>18</b>
[18.112] Slip clutch or flywheel damper .....	18.1
<b>Transmission</b> .....	<b>21</b>
[21.113] Powershift transmission .....	21.1
[21.155] Powershift transmission internal components.....	21.2
[21.160] Creeper .....	21.3
[21.166] Overdrive.....	21.4
[21.504] Continuously Variable Transmission (CVT) .....	21.5
[21.505] Continuously Variable Transmission (CVT) external controls.....	21.6
[21.507] Continuously Variable Transmission (CVT) internal components.....	21.7
[21.506] Continuously Variable Transmission (CVT) lubrication system .....	21.8
[21.109] Transmission cooler and lines.....	21.9
<b>Four-Wheel Drive (4WD) system</b> .....	<b>23</b>
[23.202] Electro-hydraulic control .....	23.1
[23.314] Drive shaft.....	23.2

<b>Front axle system .....</b>	<b>25</b>
[25.100] Powered front axle .....	25.1
[25.102] Front bevel gear set and differential .....	25.2
[25.108] Final drive hub, steering knuckles, and shafts .....	25.3
[25.122] Axle suspension control .....	25.4
<b>Rear axle system.....</b>	<b>27</b>
[27.100] Powered rear axle.....	27.1
[27.106] Rear bevel gear set and differential.....	27.2
[27.120] Planetary and final drives .....	27.3
[27.126] Spur gear and final drives.....	27.4
<b>Power Take-Off (PTO).....</b>	<b>31</b>
[31.101] Rear mechanical control .....	31.1
[31.104] Rear electro-hydraulic control.....	31.2
[31.114] Two-speed rear Power Take-Off (PTO) .....	31.3
[31.116] Three-speed rear Power Take-Off (PTO) .....	31.4
[31.119] Four-speed rear Power Take-Off (PTO).....	31.5
[31.146] Front Power Take-Off (PTO) .....	31.6
<b>Brakes and controls .....</b>	<b>33</b>
[33.202] Hydraulic service brakes .....	33.1
[33.110] Parking brake or parking lock .....	33.2
[33.220] Trailer brake hydraulic control.....	33.3
[33.224] Trailer brake pneumatic control .....	33.4
[33.350] Anti-lock Brake System (ABS) .....	33.5
<b>Hydraulic systems.....</b>	<b>35</b>
[35.000] Hydraulic systems.....	35.1
[35.300] Reservoir, cooler, and filters.....	35.2
[35.106] Variable displacement pump .....	35.3
[35.102] Pump control valves.....	35.4

[35.105] Charge pump.....	35.5
[35.230] Priority valves .....	35.6
[35.322] Regulated/Low pressure system.....	35.7
[35.204] Remote control valves .....	35.8
[35.220] Auxiliary hydraulic pump .....	35.9
[35.114] Three-point hitch control valve .....	35.10
[35.160] Front hitch controls and lines .....	35.11
[35.162] Front hitch cylinders and lines .....	35.12
<b>Pneumatic system .....</b>	<b>36</b>
[36.100] Pneumatic system.....	36.1
<b>Hitches, drawbars, and implement couplings.....</b>	<b>37</b>
[37.120] Rear three-point hitch linkage.....	37.1
[37.110] Rear three-point hitch .....	37.2
[37.162] Front hitch.....	37.3
[37.106] Automatic pickup hitch .....	37.4
<b>Frames and ballasting .....</b>	<b>39</b>
[39.100] Frame .....	39.1
<b>Steering.....</b>	<b>41</b>
[41.101] Steering control .....	41.1
[41.106] Tie rods.....	41.2
[41.200] Hydraulic control components.....	41.3
[41.216] Cylinders .....	41.4
[41.432] Autoguidance steering .....	41.5
<b>Wheels .....</b>	<b>44</b>
[44.511] Front wheels.....	44.1
[44.520] Rear wheels.....	44.2
<b>Cab climate control .....</b>	<b>50</b>

[50.100] Heating .....	50.1
[50.104] Ventilation .....	50.2
[50.200] Air conditioning .....	50.3
<b>Electrical systems .....</b>	<b>55</b>
[55.000] Electrical system .....	55.1
[55.100] Harnesses and connectors .....	55.2
[55.640] Electronic modules .....	55.3
[55.015] Engine control system .....	55.4
[55.301] Alternator .....	55.5
[55.302] Battery .....	55.6
[55.011] Fuel tank system .....	55.7
[55.010] Fuel injection system .....	55.8
[55.988] Selective Catalytic Reduction (SCR) electrical system .....	55.9
[55.513] Cab transmission controls .....	55.10
[55.020] Transmission speed sensors .....	55.11
[55.021] Transmission pressure sensors .....	55.12
[55.022] Transmission temperature sensors .....	55.13
[55.023] Transmission position sensors .....	55.14
[55.610] Ground speed control .....	55.15
[55.045] Front axle control system .....	55.16
[55.048] Rear Power Take-Off (PTO) control system .....	55.17
[55.049] Front Power Take-Off (PTO) control system .....	55.18
[55.031] Parking brake electrical system .....	55.19
[55.035] Remote control valve electric control .....	55.20
[55.051] Cab Heating, Ventilation, and Air-Conditioning (HVAC) controls .....	55.21
[55.050] Heating, Ventilation, and Air-Conditioning (HVAC) control system .....	55.22
[55.047] Steering control system .....	55.23
[55.523] Cab hitch controls .....	55.24
[55.130] Rear three-point hitch electronic control system .....	55.25

[55.911] Global Positioning System (GPS) .....	55.26
[55.408] Warning indicators, alarms, and instruments .....	55.27
[55.350] Anti-lock Brake System (ABS) electrical system .....	55.28
[55.512] Cab controls .....	55.29
[55.030] Service brake electrical system .....	55.30
[55.510] Cab or platform harnesses and connectors .....	55.31
[55.DTC] FAULT CODES .....	55.32
<b>Platform, cab, bodywork, and decals .....</b>	<b>90</b>
[90.100] Engine hood and panels .....	90.1
[90.150] Cab .....	90.2



# INTRODUCTION

# Contents

---

## INTRODUCTION

Safety rules .....	3
Safety rules - Ecology and the environment .....	4
Basic instructions - Important notice regarding equipment servicing .....	5
Basic instructions - Shop and assembly .....	6
Torque - Minimum tightening torques for normal assembly .....	8
Torque - Standard torque data for hydraulics .....	13
Hydraulic contamination .....	15
Capacities .....	16
Consumables .....	17

## Safety rules

### Personal safety





This is the safety alert symbol. It is used to alert you to potential personal injury hazards. Obey all safety messages that follow this symbol to avoid possible death or injury.

Throughout this manual you will find the signal words DANGER, WARNING, and CAUTION followed by special instructions. These precautions are intended for the personal safety of you and those working with you.

Read and understand all the safety messages in this manual before you operate or service the machine.

 DANGER indicates a hazardous situation that, if not avoided, will result in death or serious injury.

 WARNING indicates a hazardous situation that, if not avoided, could result in death or serious injury.

 CAUTION indicates a hazardous situation that, if not avoided, could result in minor or moderate injury.

**FAILURE TO FOLLOW DANGER, WARNING, AND CAUTION MESSAGES COULD RESULT IN DEATH OR SERIOUS INJURY.**

### Machine safety

**NOTICE:** Notice indicates a situation that, if not avoided, could result in machine or property damage.

Throughout this manual you will find the signal word Notice followed by special instructions to prevent machine or property damage. The word Notice is used to address practices not related to personal safety.

### Information

**NOTE:** Note indicates additional information that clarifies steps, procedures, or other information in this manual.

Throughout this manual you will find the word Note followed by additional information about a step, procedure, or other information in the manual. The word Note is not intended to address personal safety or property damage.

---

## Safety rules - Ecology and the environment

Soil, air, and water quality is important for all industries and life in general. When legislation does not yet rule the treatment of some of the substances that advanced technology requires, sound judgment should govern the use and disposal of products of a chemical and petrochemical nature.

Familiarize yourself with the relative legislation applicable to your country, and make sure that you understand this legislation. Where no legislation exists, obtain information from suppliers of oils, filters, batteries, fuels, anti-freeze, cleaning agents, etc., with regard to the effect of these substances on man and nature and how to safely store, use, and dispose of these substances.

### Helpful hints

- Avoid the use of cans or other inappropriate pressurized fuel delivery systems to fill tanks. Such delivery systems may cause considerable spillage.
- In general, avoid skin contact with all fuels, oils, acids, solvents, etc. Most of these products contain substances that may be harmful to your health.
- Modern oils contain additives. Do not burn contaminated fuels and or waste oils in ordinary heating systems.
- Avoid spillage when you drain fluids such as used engine coolant mixtures, engine oil, hydraulic fluid, brake fluid, etc. Do not mix drained brake fluids or fuels with lubricants. Store all drained fluids safely until you can dispose of the fluids in a proper way that complies with all local legislation and available resources.
- Do not allow coolant mixtures to get into the soil. Collect and dispose of coolant mixtures properly.
- The air-conditioning system contains gases that should not be released into the atmosphere. Consult an air-conditioning specialist or use a special extractor to recharge the system properly.
- Repair any leaks or defects in the engine cooling system or hydraulic system immediately.
- Do not increase the pressure in a pressurized circuit as this may lead to a component failure.
- Protect hoses during welding. Penetrating weld splatter may burn a hole or weaken hoses, allowing the loss of oils, coolant, etc.

### Battery recycling

Batteries and electric accumulators contain several substances that can have a harmful effect on the environment if the batteries are not properly recycled after use. Improper disposal of batteries can contaminate the soil, groundwater, and waterways. NEW HOLLAND strongly recommends that you return all used batteries to a NEW HOLLAND dealer, who will dispose of the used batteries or recycle the used batteries properly. In some countries, this is a legal requirement.



### Mandatory battery recycling

**NOTE:** *The following requirements are mandatory in Brazil.*

Batteries are made of lead plates and a sulfuric acid solution. Because batteries contain heavy metals such as lead, CONAMA Resolution 401/2008 requires you to return all used batteries to the battery dealer when you replace any batteries. Do not dispose of batteries in your household garbage.

Points of sale are obliged to:

- Accept the return of your used batteries
- Store the returned batteries in a suitable location
- Send the returned batteries to the battery manufacturer for recycling



# **SERVICE MANUAL**

## **Engine**

**T7.230 AutoCommand™, T7.230, T7.245 AutoCommand™, T7.245, T7.260  
AutoCommand™, T7.260, T7.270 AutoCommand™**

## Engine - Remove

### Prior operation:

Separate the front axle and front frame from the engine, for further information refer to **Front frame - Remove (39.100)**

### Prior operation:

Remove the left-hand fuel tank, for further information refer to **Fuel tank - Remove (10.216)**

### Prior operation:

Remove the selective catalytic reduction (SRC) muffler, for further information refer to **Selective Catalytic Reduction (SCR) muffler and catalyst - Remove (10.500)**

### Prior operation:

Remove the engine hood, for further information refer to **Hood - Remove (90.100)**

### ⚠ WARNING

#### Heavy objects!

Lift and handle all heavy components using lifting equipment with adequate capacity. Always support units or parts with suitable slings or hooks. Make sure the work area is clear of all bystanders.

Failure to comply could result in death or serious injury.

W0398A

### ⚠ WARNING

#### Avoid injury!

Handle all parts carefully. Do not place your hands or fingers between parts. Use Personal Protective Equipment (PPE) as indicated in this manual, including protective goggles, gloves, and safety footwear.

Failure to comply could result in death or serious injury.

W0208A

**NOTICE:** Avoid DEF/AdBLUE® contamination of the electrical connector by disconnecting the DEF/AdBLUE® connectors first.

1. Disconnect the radar electrical connector (if fitted).
2. Remove the radar (if fitted).

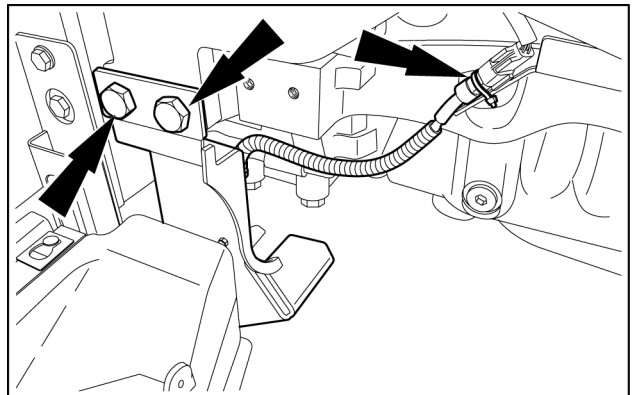

BAIL13TR01648AB 1

### Vehicles with front hitch

2. Disconnect the mid-mount pipes from the mid-mount valve.

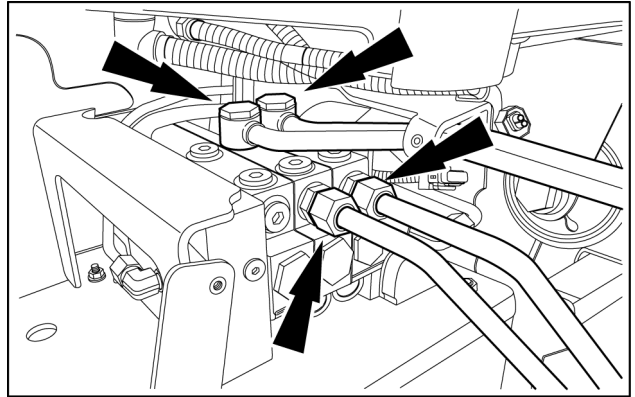

BAIL13TR01645AB 2

3. Remove the front hitch pipes.

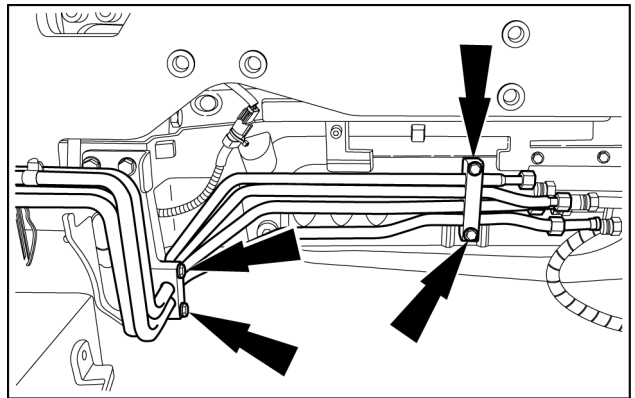

BAIL13TR01647AB 3

4. Remove the starter motor cover.

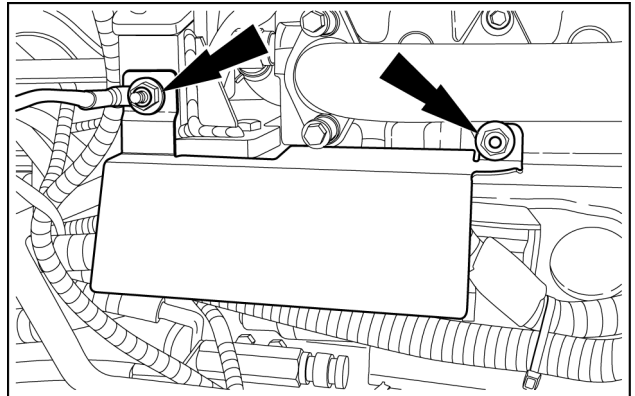

BAIL14TR00276AB 4

5. Remove the oil cooler pipe bracket.

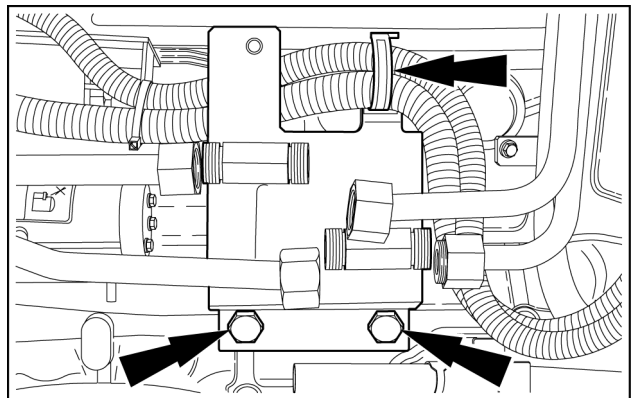

BAIL14TR00277AB 5

6. Detach the fuse box and position it to one side.

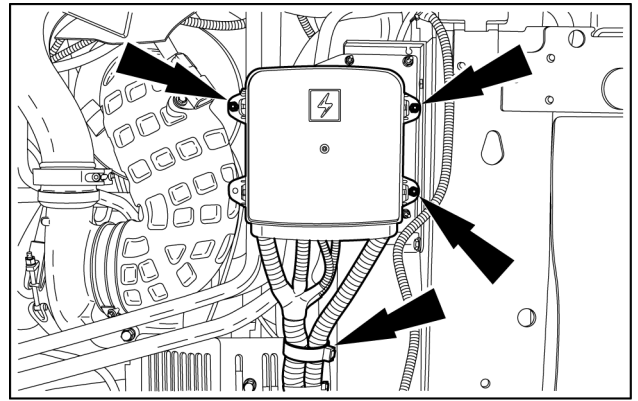

BAIL13TR01663AB 6

7. Disconnect the starter motor positive cables.

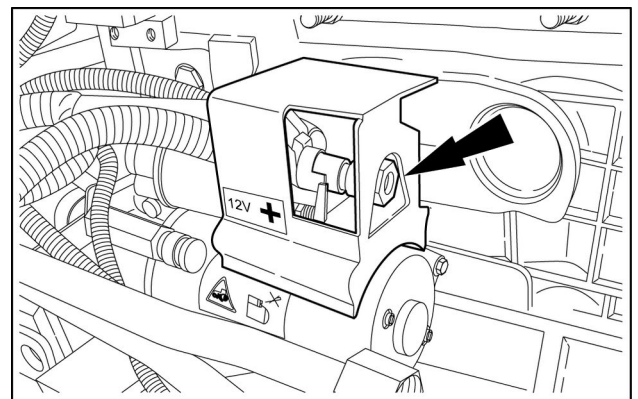

BAIL14TR00278AA 7

8. Disconnect the starter motor electrical connector.

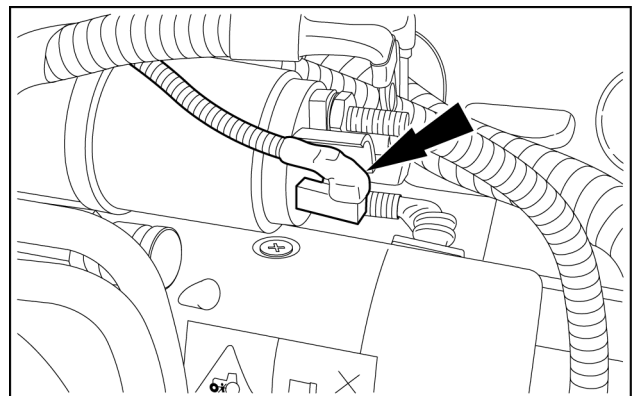

BAIL13TR01660AB 8

9. Disconnect the starter motor negative terminal.

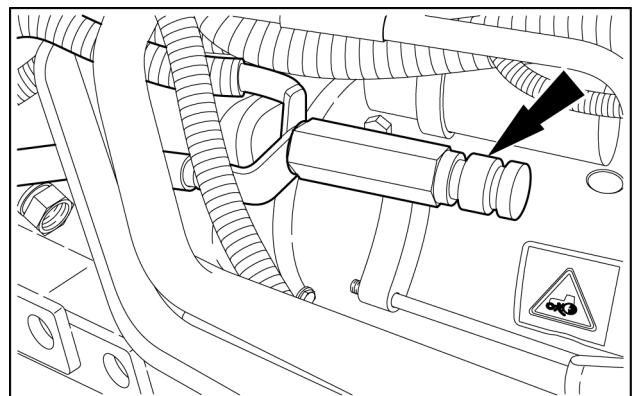

BAIL13TR01661AB 9



**Suggest:**

**If the above button click is invalid.**

**Please download this document**

**first, and then click the above link**

**to download the complete manual.**

**Thank you so much for reading**

10. Disconnect the front axle electrical connectors.

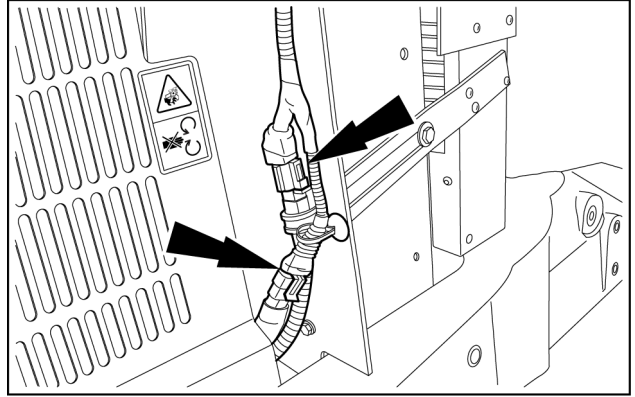

BAIL13TR01683AB 10

11. Disconnect the brake master cylinder oil supply pipes.

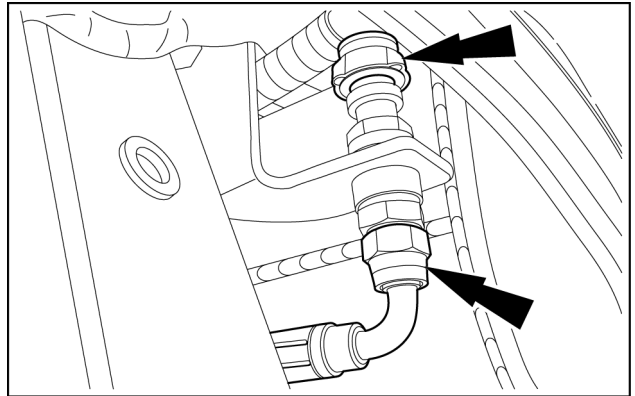

BAIL14TR00279AB 11

12. Disconnect the cab hand rail light electrical connectors (on both sides).

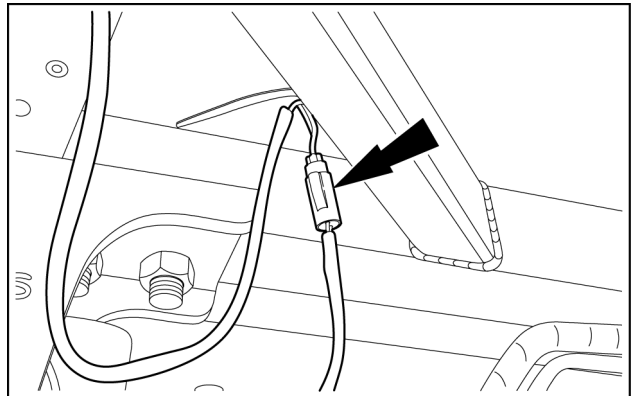

BAIL14TR00280AB 12

13. 1. Disconnect the steering pipes.  
2. Disconnect the brake pipe.

**NOTE:** Mark the hoses to aid installation.

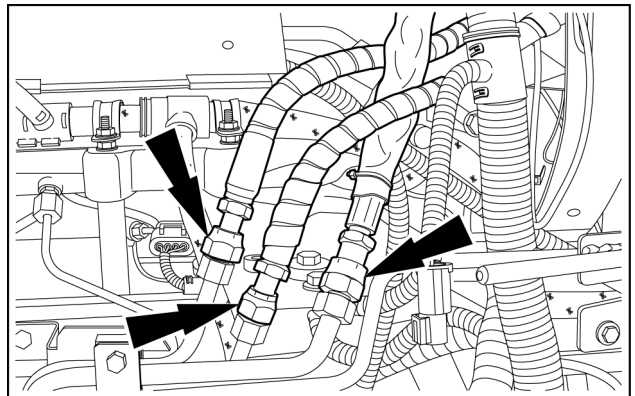

BAIL14TR00281AB 13

**<https://www.ebooklibonline.com>**

Hello dear friend!

Thank you very much for reading.

Enter the link into your browser.

The full manual is available for immediate download.

**<https://www.ebooklibonline.com>**