

SERVICE MANUAL

TD4.70F / TD4.80F / TD4.90F
Tractor

Part number 47913129

English
February 2016





SERVICE MANUAL

**TD4.70F
TD4.80F
TD4.90F**

Contents

INTRODUCTION

Engine.....	10
[10.001] Engine and crankcase	10.1
Clutch	18
[18.100] Clutch mechanical release control	18.1
[18.110] Clutch and components	18.2
Transmission.....	21
[21.114] Mechanical transmission	21.1
[21.160] Creeper	21.2
[21.162] Reverser	21.3
[21.182] Differential.....	21.4
Four-Wheel Drive (4WD) system	23
[23.202] Electro-hydraulic control	23.1
[23.304] Four-Wheel Drive (4WD) gearbox	23.2
Front axle system	25
[25.100] Powered front axle	25.1
[25.102] Front bevel gear set and differential	25.2
[25.108] Final drive hub, steering knuckles, and shafts	25.3
[25.310] Final drives	25.4
Rear axle system.....	27
[27.100] Powered rear axle.....	27.1
[27.106] Rear bevel gear set and differential.....	27.2
Power Take-Off (PTO).....	31
[31.101] Rear mechanical control	31.1
Brakes and controls	33
[33.220] Trailer brake hydraulic control.....	33.1

<https://www.ebooklibonline.com>

Hello dear friend!

Thank you very much for reading.

Enter the link into your browser.

The full manual is available for immediate download.

<https://www.ebooklibonline.com>

[33.202] Hydraulic service brakes	33.2
[33.110] Parking brake or parking lock	33.3
Hydraulic systems.....	35
[35.204] Remote control valves	35.1
[35.114] Three-point hitch control valve	35.2
[35.322] Regulated/Low pressure system.....	35.3
Hitches, drawbars, and implement couplings.....	37
[37.110] Rear three-point hitch	37.1
Steering.....	41
[41.206] Pump	41.1
[41.216] Cylinders	41.2
[41.200] Hydraulic control components.....	41.3
Electrical systems	55
[55.518] Wiper and washer system.....	55.1
[55.301] Alternator.....	55.2
[55.201] Engine starting system	55.3
[55.051] Cab Heating, Ventilation, and Air-Conditioning (HVAC) controls.....	55.4
[55.523] Cab hitch controls	55.5
[55.408] Warning indicators, alarms, and instruments	55.6
[55.302] Battery.....	55.7
[55.100] Harnesses and connectors.....	55.8
Platform, cab, bodywork, and decals.....	90
[90.154] Cab doors and hatches	90.1
[90.151] Cab interior.....	90.2



INTRODUCTION

Contents

INTRODUCTION

International symbols	3
Safety rules	4
Safety rules	16
Personal safety	20
Basic instructions Hardware	21
Torque Specification Tables	22
Basic instructions - Shop and Assembly	27

International symbols

As a guide to the operation of the machine, various universal symbols have been utilized on the instruments, controls, switches, and fuse box. The symbols are shown below with an indication of their meaning.

	Thermostart starting aid		Radio		PTO		Position Control
	Alternator charge	KAM	Keep alive memory	N	Transmission in neutral		Draft Control
	Fuel level		Turn signals		Creeper gears		Accessory socket
	Automatic Fuel shut-off		Turn signals -one trailer		Slow or low setting		Implement socket
	Engine speed (rev/min x 100)		Turn signals -two trailers		Fast or high setting		%age slip
	Hours recorded		Front wind-screen wash/wipe		Ground speed		Hitch raise (rear)
	Engine oil pressure		Rear wind-screen wash/wipe		Differential lock		Hitch lower (rear)
	Engine coolant temperature		Heater temperature control		Rear axle oil temperature		Hitch height limit (rear)
	Coolant level		Heater fan		Transmission oil pressure		Hitch height limit (front)
	Tractor lights		Air conditioner		FWD engaged		Hitch disabled
	Headlamp main beam		Air filter blocked		FWD dis-engaged		Hydraulic and transmission filters
	Headlamp dipped beam		Parking brake		Warning!		Remote valve extend
	Work lamps		Brake fluid level		Hazard warning lights		Remote valve retract
	Stop lamps		Trailer brake		Variable control		Remote valve float
	Horn		Roof beacon		Pressurised! Open carefully		Malfunction! See Operator's Manual
			Warning ! Corrosive substance				Malfunction! (alternative symbol)

Safety rules

IMPORTANT NOTICE

All maintenance and repair operations described in this manual should be carried out exclusively by authorised workshops. All instructions should be carefully observed and special equipment where indicated should be used. Anyone who carries out service operations described without carefully observing these instructions will be directly responsible for any damage caused.

NOTES FOR EQUIPMENT

Equipment shown in this manual is:

- designed expressly for use on these tractors;
- necessary to make a reliable repair;
- accurately built and strictly tested to offer efficient and long-lasting working life.

NOTICES

The words “front”, “rear”, “right hand”, and “left hand” refer to the different parts as seen from the operator’s seat oriented to the normal direction of movement of the tractor.

SAFETY RULES

PAY ATTENTION TO THIS SYMBOL



This warning symbol points out important messages involving personal safety. Carefully read the safety rules contained herein and follow advised precautions to avoid potential hazards and safeguard your safety. In this manual you will find this symbol together with the following key-words:
WARNING -it gives warning about improper repair operations and potential consequences affecting the service technician’s personal safety.
DANGER - it gives specific warning about potential dangers for personal safety of the operator or other persons directly or indirectly involved in the operation.



TO PREVENT ACCIDENTS

Most accidents and personal injuries taking place in workshops are due from non-observance of some essential rules and safety precautions.

The possibility that an accident might occur with any type of machines should not be disregarded, no matter how well the machine in question was designed and built.

A wise and careful service technician is the best precautions against accidents.

Careful observance of this basic precaution would be enough to avoid many severe accidents.

SAFETY RULES

Generalities

- Carefully follow specified repair and maintenance procedures.
- Do not wear rings, wristwatches, jewels, unbuttoned or flapping clothing such as ties, torn clothes, scarves, open jackets or shirts with open zips which could get caught on moving parts. Use approved safety clothing such as anti-slipping footwear, gloves, safety goggles, helmets, etc.
- Wear safety glasses with side guards when cleaning parts using compressed air.
- Damaged or frayed wires and chains are unreliable. Do not use them for lifting or towing.

- Wear suitable protection such as approved eye protection, helmets, special clothing, gloves and footwear whenever welding. All persons standing in the vicinity of the welding process should wear approved eye protection. NEVER LOOK AT THE WELDING ARC IF YOUR EYES ARE NOT SUITABLY PROTECTED.
- Never carry out any repair on the machine if someone is sitting on the operator's seat, except if they are qualified operators assisting in the operation to be carried out.
- Never operate the machine or use attachments from a place other than sitting at the operator's seat or at the side of the machine when operating the fender switches.
- Never carry out any operation on the machine when the engine is running, except when specifically indicated. Stop the engine and ensure that all pressure is relieved from hydraulic circuits before removing caps, covers, valves, etc.
- All repair and maintenance operations should be carried out with the greatest care and attention.
- Disconnect the batteries and label all controls to warn that the tractor is being serviced. Block the machine and all equipment which should be raised.
- Never check or fill fuel tanks or batteries, nor use starting liquid if you are smoking or near open flames as such fluids are flammable.
- The fuel filling gun should always remain in contact with the filler neck. Maintain this contact until the fuel stops flowing into the tank to avoid possible sparks due to static electricity build-up.
- To transfer a failed tractor, use a trailer or a low loading platform trolley if available.
- To load and unload the machine from the transportation means, select a flat area providing a firm support to the trailer or truck wheels. Firmly tie the machine to the truck or trailer platform and block wheels as required by the transporter.
- Always use lifting equipment of appropriate capacity to lift or move heavy components.
- Chains should always be safely fastened. Ensure that fastening device is strong enough to hold the load foreseen. No persons should stand near the fastening point.
- The working area should be always kept CLEAN and DRY. Immediately clean any spillage of water or oil.
- Never use gasoline, diesel oil or other flammable liquids as cleaning agents. Use non-flammable non-toxic proprietary solvents.
- Do not pile up grease or oil soaked rags, as they constitute a great fire hazard. Always place them into a metal container.

START UP

- Never run the engine in confined spaces which are not equipped with adequate ventilation for exhaust gas extraction.
- Never bring your head, body, arms, legs, feet, hands, fingers near fans or rotating belts.

ENGINE

- Always loosen the radiator cap very slowly before removing it to allow pressure in the system to dissipate. Coolant should be topped up only when the engine is stopped.
- Do not fill up fuel tank when the engine is running.
- Never adjust the fuel injection pump when the tractor is moving.
- Never lubricate the tractor when the engine is running.

ELECTRICAL SYSTEMS

- If it is necessary to use auxiliary batteries, cables must be connected at both sides as follows: (+) to (+) and (-) to (-). Avoid short-circuiting the terminals. GAS RELEASED FROM BATTERIES IS HIGHLY FLAMMABLE. During charging, leave the battery compartment uncovered to improve ventilation. Avoid sparks or flames near the battery area. Do no smoke.
- Do not charge batteries in confined spaces.
- Always disconnect the batteries before performing any type of service on the electrical system.



SERVICE MANUAL

Engine

TD4.70F

TD4.80F

TD4.90F

Contents

Engine - 10

[10.001] Engine and crankcase	10.1
-------------------------------------	------



Engine - 10

Engine and crankcase - 001

**TD4.70F
TD4.80F
TD4.90F**

Contents

Engine - 10

Engine and crankcase - 001

SERVICE

Engine

Remove	3
Install	16

Engine - Remove

⚠ DANGER

Heavy objects!

Lift and handle all heavy components using lifting equipment with adequate capacity. Always support units or parts with suitable slings or hooks. Make sure the work area is clear of all bystanders.

Failure to comply will result in death or serious injury.

D0076A

⚠ CAUTION

Pinch hazard!

Always use suitable tools to align mating parts. DO NOT use your hand or fingers.

Failure to comply could result in minor or moderate injury.

C0044A

To access the clutch it is necessary to separate the engine complete with the front axle from the transmission.

Proceed as follows:

1. Disconnect the negative battery lead **(1)** .

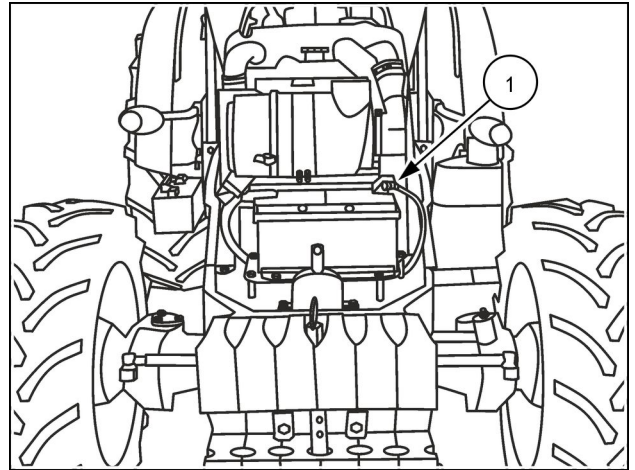

AKU 1

2. Drain off the oil from the gearbox/transmission casing.
3. Drain off the coolant from the engine cooling system.
4. Remove the exhaust pipe. Attach lifting chains **(2)** to the bonnet **(1)** and attach the chain to the hoist.

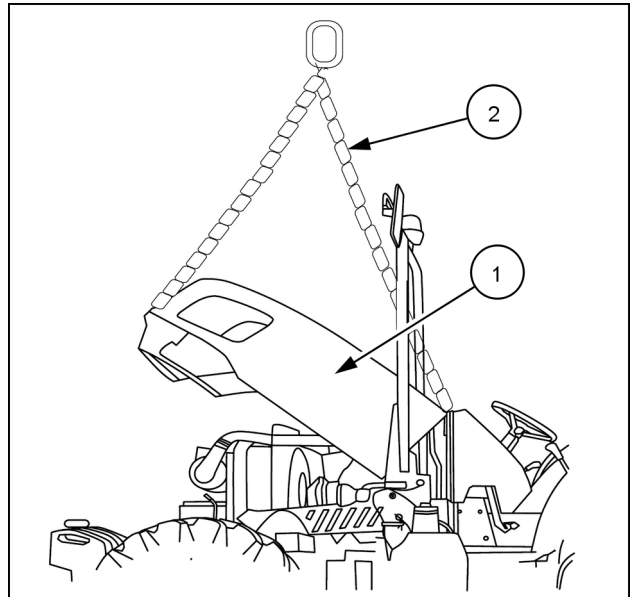

KAPUTKALDIRMA 2

5. Disconnect the electrical connection **(1)** of bonnet.

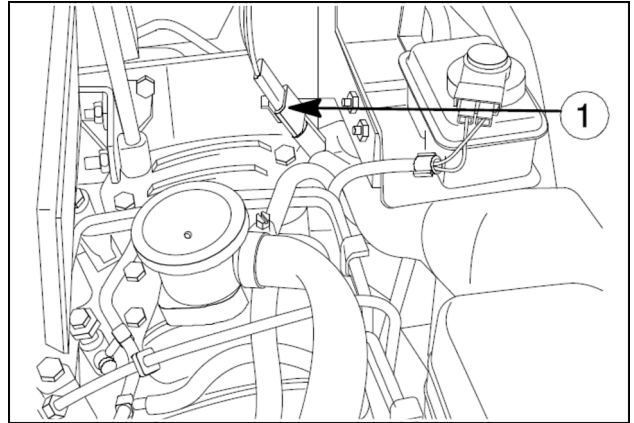

CLUTCH3 3

6. Detach the gas strut **(1)** from the bonnet.

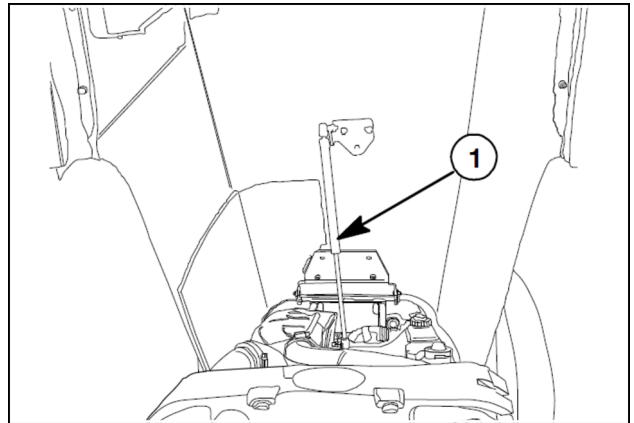

CLUTCH4 4

7. Remove the two bonnet hinge bolts **(1)** and take out the spacers **(2)** lift the bonnet clear.

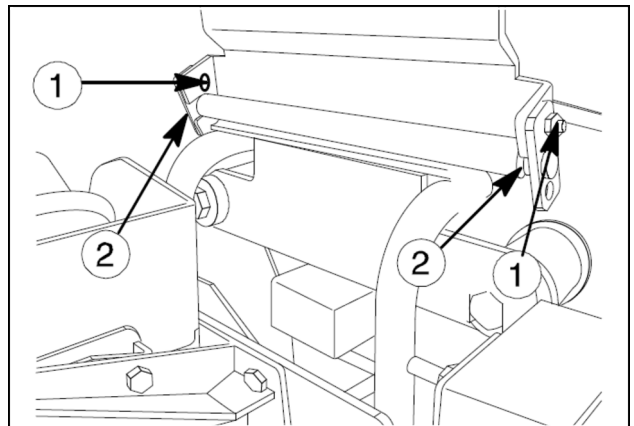

CLUTCH5 5

8. Disconnect the two retaining bolts of the guard **(1)** both on the right and left hand side of the engine.

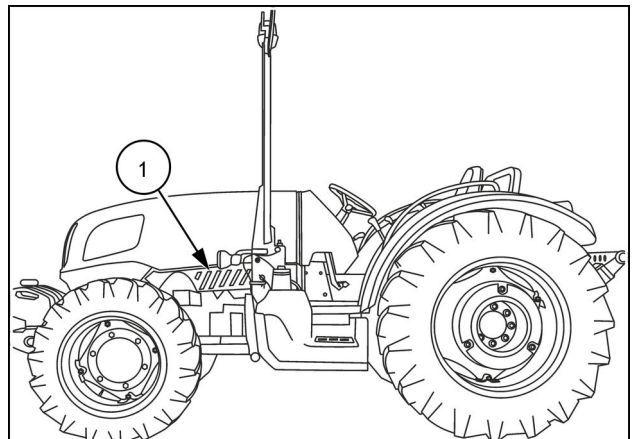

SOLDAN 6

9. Unscrew the nut **(1)** from the weight retaining pin. Remove the weights from the front support.

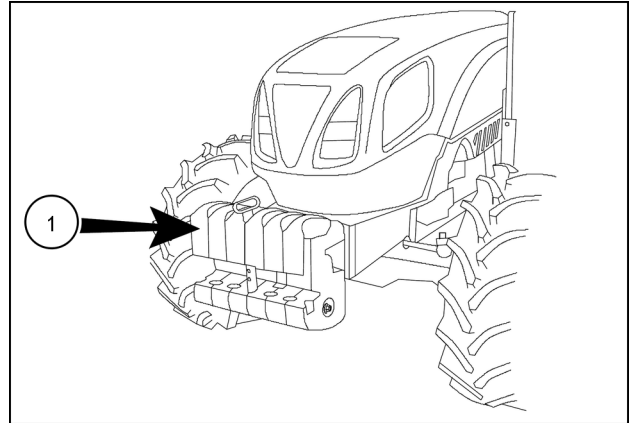

AGIRLIKLAR 7

10. Unscrew the front central and rear retaining bolts on the front axle shaft guard, then remove the guard **(1)**.

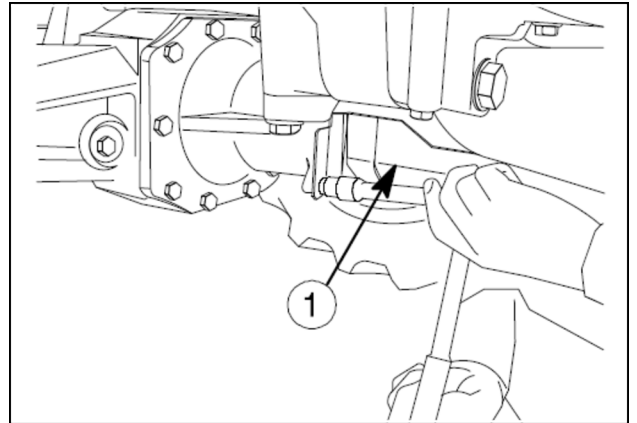

CLUTCH9 8

11. Remove the circlip **(2)** and move the front sleeve **(1)** in the direction indicated by the arrow until it is released from the groove on the front axle

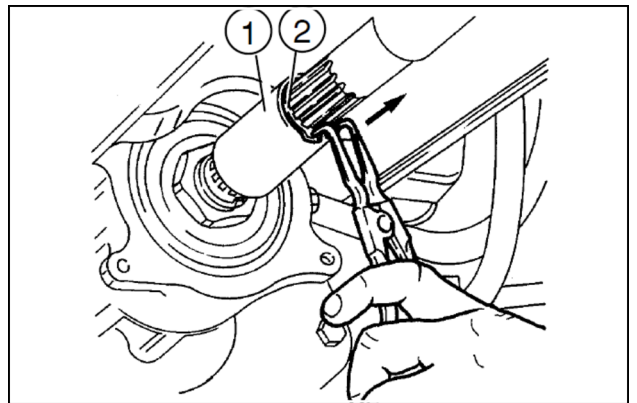

CLUTCH10 9

12. Remove the circlip **(2)** and move the rear sleeve **(1)** in the direction indicated by the arrow until it is released from the groove on the drive.

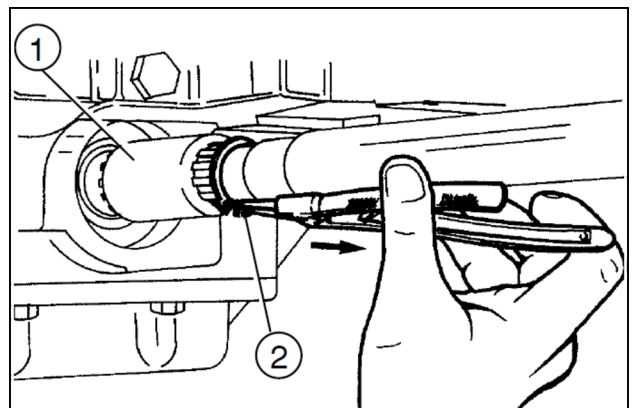

CLUTCH11 10



Suggest:

If the above button click is invalid.

Please download this document

first, and then click the above link

to download the complete manual.

Thank you so much for reading

13. Remove the propeller shaft central support (1) retaining bolts (2) and extract the shaft together with the support.

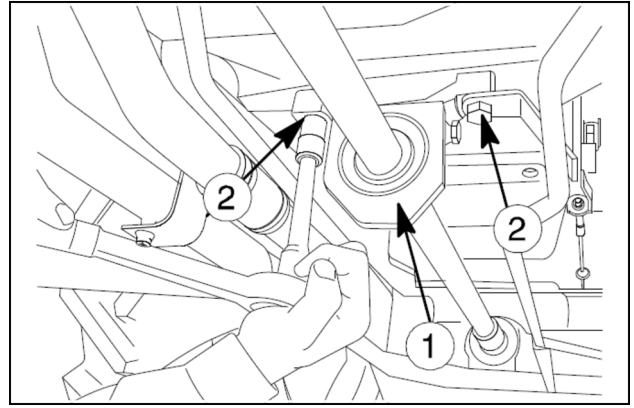

CLUTCH12 11

14. Disconnect the pressure pipe connection (1) of the hydrostatic steering pump.

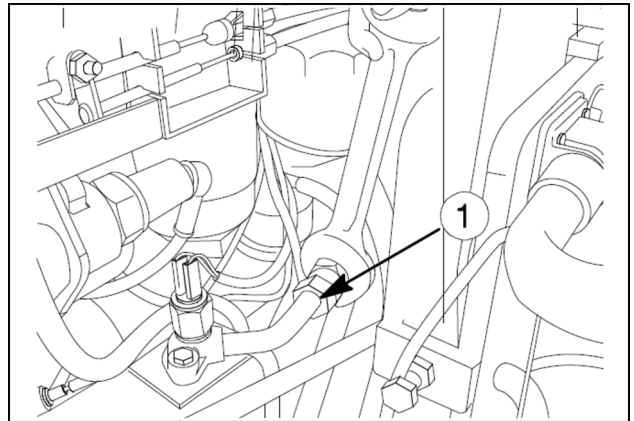

CLUTCH13 12

15. Disconnect the pressure pipe connection (1) of the lift pump.

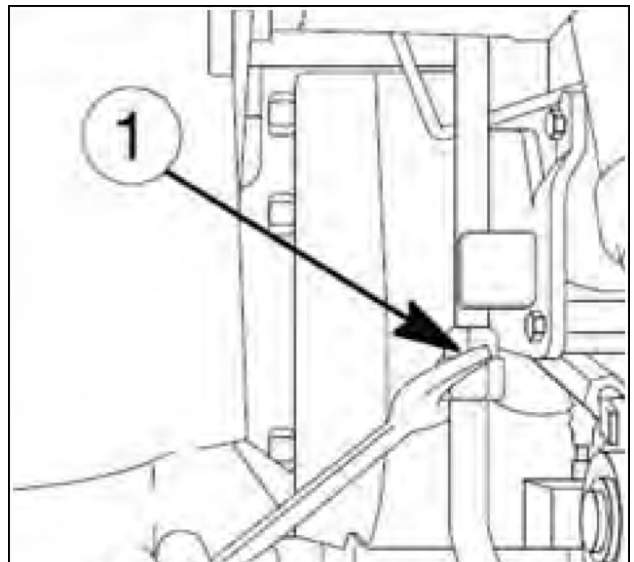

CULTCH13 13

<https://www.ebooklibonline.com>

Hello dear friend!

Thank you very much for reading.

Enter the link into your browser.

The full manual is available for immediate download.

<https://www.ebooklibonline.com>