

# SERVICE MANUAL

**TC5040 / TC5050 / TC5060  
TC5070 / TC5080 / TC5080 Hillside  
Combines**

I/2

Print No. 87734472B





## SERVICE MANUAL

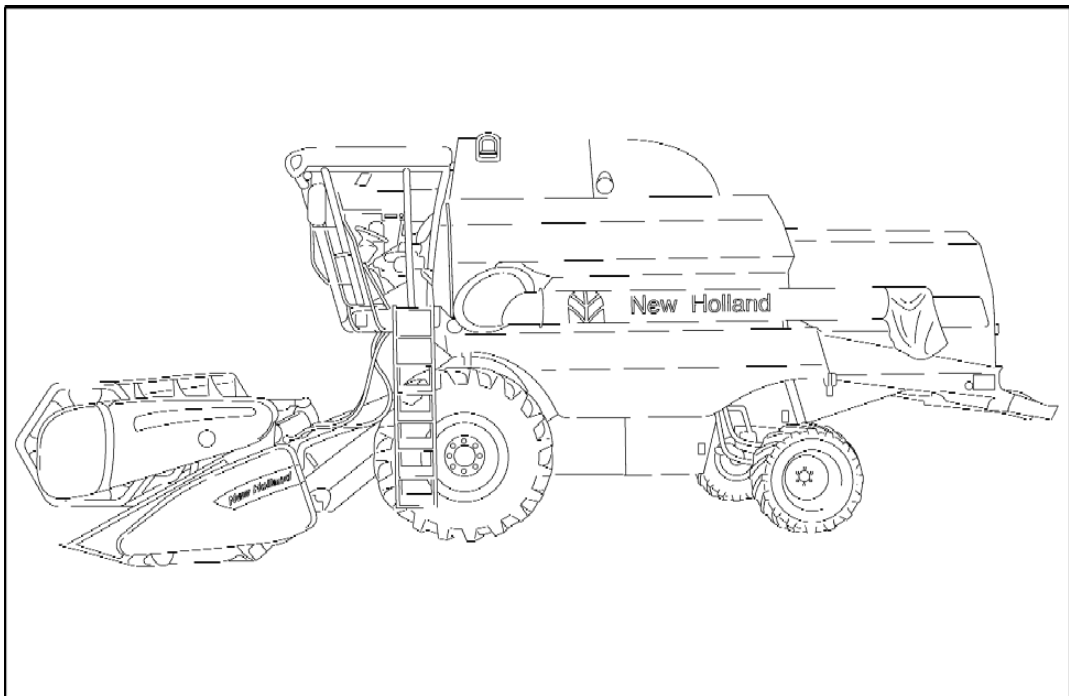

**TC5040 , TC5050 , TC5060 , TC5070 , TC5080 Hillside , TC5080**

# Contents

---

INTRODUCTION	
DISTRIBUTION SYSTEMS.....	A
PRIMARY HYDRAULIC POWER SYSTEM.....	A.10.A
ELECTRICAL POWER SYSTEM .....	A.30.A
ELECTRONIC SYSTEM .....	A.50.A
FAULT CODES.....	A.50.A
POWER TRAIN.....	C
POWER COUPLING Clutch.....	C.10.C
TRANSMISSION Mechanical .....	C.20.B
TRANSMISSION Hydrostatic.....	C.20.F
TRAVELLING.....	D
FRONT AXLE .....	D.10.A
REAR AXLE .....	D.12.A
STEERING Hydraulic.....	D.20.C
SERVICE BRAKE Mechanical .....	D.30.B
SERVICE BRAKE Hydraulic.....	D.30.C
PARKING BRAKE Mechanical .....	D.32.B
BODY AND STRUCTURE .....	E
USER PLATFORM .....	E.34.A
ENVIRONMENT CONTROL Air-conditioning system.....	E.40.C
FRAME POSITIONING .....	F
FRAME LEVELLING .....	F.30.A
TOOL POSITIONING.....	G
LEVELLING .....	G.30.A
CROP PROCESSING.....	K
FEEDING Feeder housing .....	K.25.E
THRESHING Conventional threshing .....	K.40.B
SEPARATING Beating.....	K.42.B

**<https://www.ebooklibonline.com>**

Hello dear friend!

Thank you very much for reading.

Enter the link into your browser.

The full manual is available for immediate download.

**<https://www.ebooklibonline.com>**

SEPARATING Straw walker .....	K.42.E
STORING AND HANDLING Grain storing .....	K.60.B
CLEANING Primary cleaning.....	K.62.B
CLEANING Tailings return system .....	K.62.C
RESIDUE HANDLING Straw chopper.....	K.64.C



# INTRODUCTION

## Foreword

TC5000

### IMPORTANT INFORMATION

All repair and maintenance works listed in this manual must be carried out only by staff belonging to the NEW HOLLAND Service network, strictly complying with the instructions given and using, whenever required, the special tools.

Anyone who carries out the above operations without complying with the prescriptions shall be responsible for the subsequent damages.

The manufacturer and all the organizations of its distribution chain, including - without limitation - national, regional or local dealers, reject any responsibility for damages due to the anomalous behavior of parts and/or components not approved by the manufacturer himself, including those used for the servicing or repair of the product manufactured or marketed by the Manufacturer. In any case, no warranty is given or attributed on the product manufactured or marketed by the Manufacturer in case of damages due to an anomalous behavior of parts and/or components not approved by the Manufacturer.

No reproduction, though partial of text and illustrations allowed

## Foreword

TC5000

### Technical Information

This manual has been produced by a new technical information system. This new system is designed to deliver technical information electronically through CD-ROM and in paper manuals. A coding system called ICE has been developed to link the technical information to other Product Support functions e.g. Warranty.

Technical information is written to support the maintenance and service of the functions or systems on a customers machine. When a customer has a concern on his machine it is usually because a function or system on his machine is not working at all, is not working efficiently, or is not responding correctly to his commands. When you refer to the technical information in this manual to resolve that customers concern, you will find all the information classified using the new ICE coding, according to the functions or systems on that machine. Once you have located the technical information for that function or system then you will find all the mechanical, electrical or hydraulic devices, components, assemblies and sub assemblies for that function or system. You will also find all the types of information that have been written for that function or system, the technical data (specifications), the functional data (how it works), the diagnostic data (fault codes and troubleshooting) and the service data (remove, install adjust, etc.).

By integrating this new ICE coding into technical information , you will be able to search and retrieve just the right piece of technical information you need to resolve that customers concern on his machine. This is made possible by attaching 3 categories to each piece of technical information during the authoring process.

The first category is the Location, the second category is the Information Type and the third category is the Product:

- LOCATION - is the component or function on the machine, that the piece of technical information is going to describe e.g. Fuel tank.
- INFORMATION TYPE - is the piece of technical information that has been written for a particular component or function on the machine e.g. Capacity would be a type of Technical Data that would describe the amount of fuel held by the Fuel tank.
- PRODUCT - is the model that the piece of technical information is written for.

Every piece of technical information will have those 3 categories attached to it. You will be able to use any combination of those categories to find the right piece of technical information you need to resolve that customers concern on his machine.

That information could be:

- the description of how to remove the cylinder head
- a table of specifications for a hydraulic pump
- a fault code
- a troubleshooting table
- a special tool

## How to Use this Manual

This manual is divided into Sections. Each Section is then divided into Chapters. Contents pages are included at the beginning of the manual, then inside every Section and inside every Chapter. An alphabetical Index is included at the end of a Chapter. Page number references are included for every piece of technical information listed in the Chapter Contents or Chapter Index.

Each Chapter is divided into four Information types:

- Technical Data (specifications) for all the mechanical, electrical or hydraulic devices, components and assemblies.
- Functional Data (how it works) for all the mechanical, electrical or hydraulic devices, components and assemblies.
- Diagnostic Data (fault codes, electrical and hydraulic troubleshooting) for all the mechanical, electrical or hydraulic devices, components and assemblies.
- Service data (remove disassembly, assemble, install) for all the mechanical, electrical or hydraulic devices, components and assemblies.

## Sections

Sections are grouped according to the main functions or a systems on the machine. Each Section is identified by a letter A, B, C etc. The amount of Sections included in the manual will depend on the type and function of the machine that the manual is written for. Each Section has a Contents page listed in alphabetic/numeric order. This table illustrates which Sections could be included in a manual for a particular product.

PRODUCT	SECTION												
	A - Distribution Systems												
	B - Power Production												
	C - Power Train												
	D - Travelling												
	E - Body and Structure												
	F - Frame Positioning												
	G - Tool Positioning												
	H - Working Arm												
	J - Tools and Couplers												
	K - Crop Processing												
	L - Field Processing												
Tractors	X	X	X	X	X	X		X	X				
Vehicles with working arms: backhoes, excavators, skid steers, .....	X	X	X	X	X	X	X	X	X				
Combines, forage harvesters, balers, ....	X	X	X	X	X	X	X	X	X	X			
Seeding, planting, floating, spraying equipment, ....	X	X	X	X	X	X	X		X		X		
Mounted equipment and tools, .....					X	X	X		X				

This manual contains these Sections. The contents of each Section are explained over the following pages.

## Contents

INTRODUCTION	
DISTRIBUTION SYSTEMS	A
POWER PRODUCTION	B
POWER TRAIN	C
TRAVELLING	D
BODY AND STRUCTURE	E
TOOL POSITIONING	G
CROP PROCESSING	K

## Section Contents

### SECTION A, DISTRIBUTION SYSTEMS

This Section covers the main systems that interact with most of the functions of the product. It includes the central parts of the hydraulic, electrical, electronic, pneumatic, lighting and grease lubrication systems. The components that are dedicated to a specific function are listed in the Chapter where all the technical information for that function is included.

### SECTION B, POWER PRODUCTION

This Section covers all the functions related to the production of power to move the machine and to drive various devices.

### SECTION C, POWER TRAIN

This Section covers all the functions related to the transmission of power from the engine to the axles and to internal or external devices and additional Process Drive functions.

### SECTION D, TRAVELLING

This Section covers all the functions related to moving the machine, including tracks, wheels, steering and braking. It covers all the axles both driven axles and non-driven axles, including any axle suspension.

### SECTION E, BODY AND STRUCTURE

This Section covers all the main functions and systems related to the structure and body of the machine. Including the frame, the shields, the operator's cab and the platform.

### SECTION G, TOOL POSITIONING

This Section covers all the functions related to the final and/or automatic positioning of the tool once the tool is positioned using the Working Arm or the machine frame.

### SECTION K, CROP PROCESSING

This Section covers all the functions related to crop processing.



# SERVICE MANUAL

## DISTRIBUTION SYSTEMS

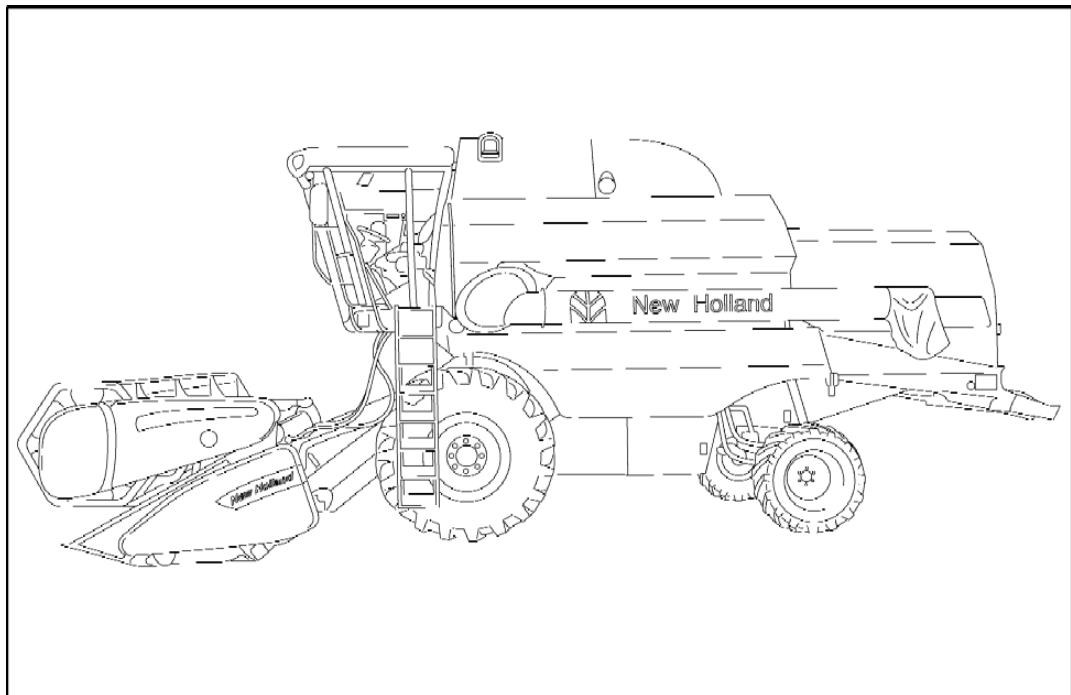

**TC5000**

## PRIMARY HYDRAULIC POWER SYSTEM - Torque

TC5000

Union nuts

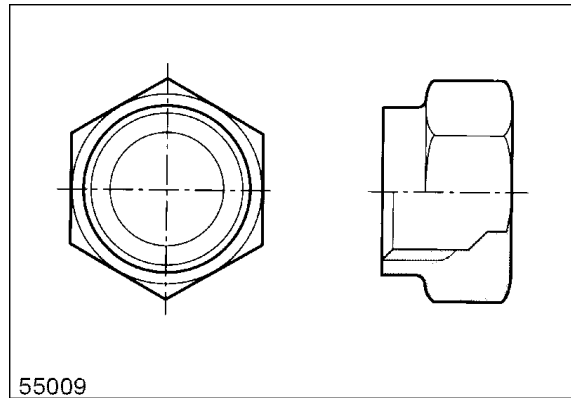

55009 1

Ferrules

The ferrule must be pre-assembled on the tube. Tighten the union nut as specified in the table below. The ferrule and screw thread are greased.

Tube outer diameter mm (inch)	Torque Nm (lb.ft)	
	Minimum	Maximum
8 (0.32)	15 (11)	20 (15)
10 (0.4)	25 (18)	30 (22)
12 (0.47)	35 (26)	40 (29)
16 (0.63)	50 (37)	55 (40)
18 (0.71)	60 (44)	70 (51)
22 (0.87)	100 (74)	110 (81)
28 (1.10)	110 (81)	120 (88)

Metric fittings

Unions

Are suitable for use with union nuts and ferrules and ball-type nipples.

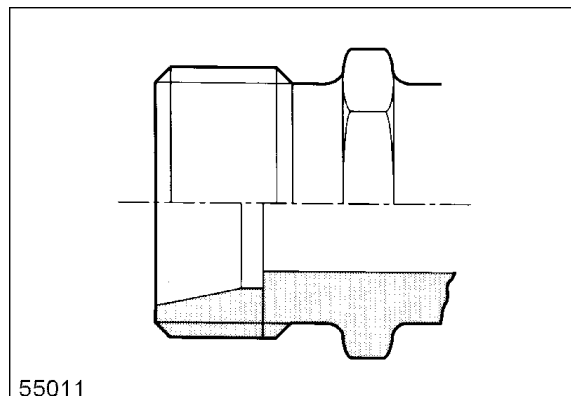

55011 2

Connections

Are screwed in ISO metric thread - tolerance class 6H - with a tightening torque as specified in the table below.

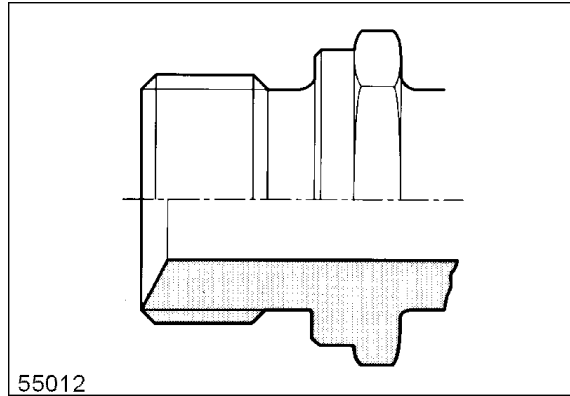

55012

55012 3

Tube outer diameter mm (inch)	Torque Nm (lb.ft)	
	Minimum	Maximum
8 (0,32)	40 (29)	45 (33)
10 (0,40)	65 (48)	70 (51)
12 (0,47)	80 (59)	85 (63)
16 (0,63)	100 (74)	120 (88)
18 (0,71)	120 (88)	140 (103)
22 (0,87)	200 (147)	220 (164)
28 (1,10)	350 (257)	380 (280)

Swivel nut with ball-type nipple

Are suitable for use with female unions

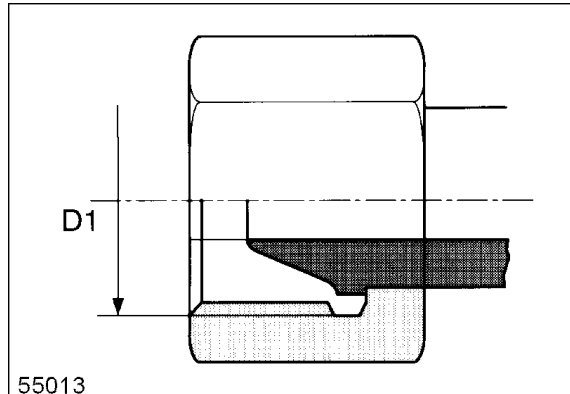

55013

55013 4

D1 6H	Torque Nm (lb.ft)	
	Minimum	Maximum
M14 x 1.5	-	-
M16 x 1.5	15 (11)	20 (15)
M18 x 1.5	20 (15)	25 (18)
M24 x 1.5	30 (22)	35 (26)
M26 x 1.5	-	-
M30 x 2	-	-
M36 x 2	-	-

## Hydraulic pump - General specification

TC5000

The hydraulic system is equipped with two pumps for models without lateral flotation, and with three pumps for models with lateral flotation.

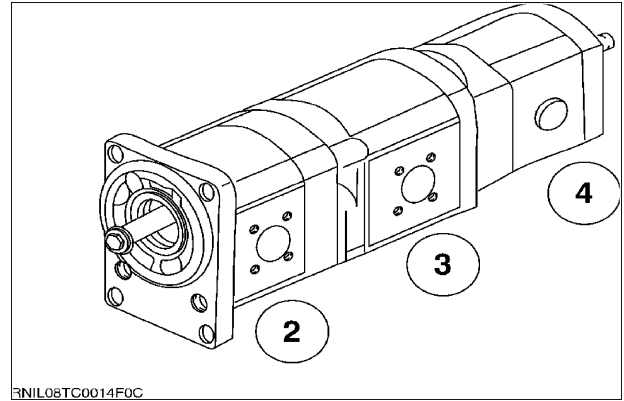

RN1L08TC0014F0C

RN1L08TC0014F0C 1

### Main hydraulic pump (2)

Type	Silence gear type
Direction of rotation	Right -hand rotation
Maximum pressure	<b>280 bar ( 4061 psi)</b>
Maximum speed	<b>3000 rpm</b>
Output per revolution	<b>16 cc/rev.</b>
Maximum oil flow	<b>48 l/min ( 10.5 gal/min)</b>

### Hydraulic pump (steering circuit) (3)

Type	Silence gear type
Direction of rotation	Right-hand rotation
Maximum pressure	<b>280 bar ( 4061 psi)</b>
Maximum speed	<b>3000 rpm</b>
Output per revolution	<b>5.5 cc/rev.</b>
Maximum oil flow	<b>16.5 l/min ( 3.6 gal/min)</b>

### Hydraulic pump (lateral flotation circuit) (4)

Type:	Gear type
Direction of rotation	Right-hand rotation
Maximum pressure	<b>230 bar ( 3336 psi)</b>
Maximum speed	<b>3000 rpm</b>
Output per revolution	<b>2 cc/rev.</b>
Maximum oil flow	<b>6 l/min ( 1.3 gal/min)</b>

# PRIMARY HYDRAULIC POWER SYSTEM - Overview

TC5000

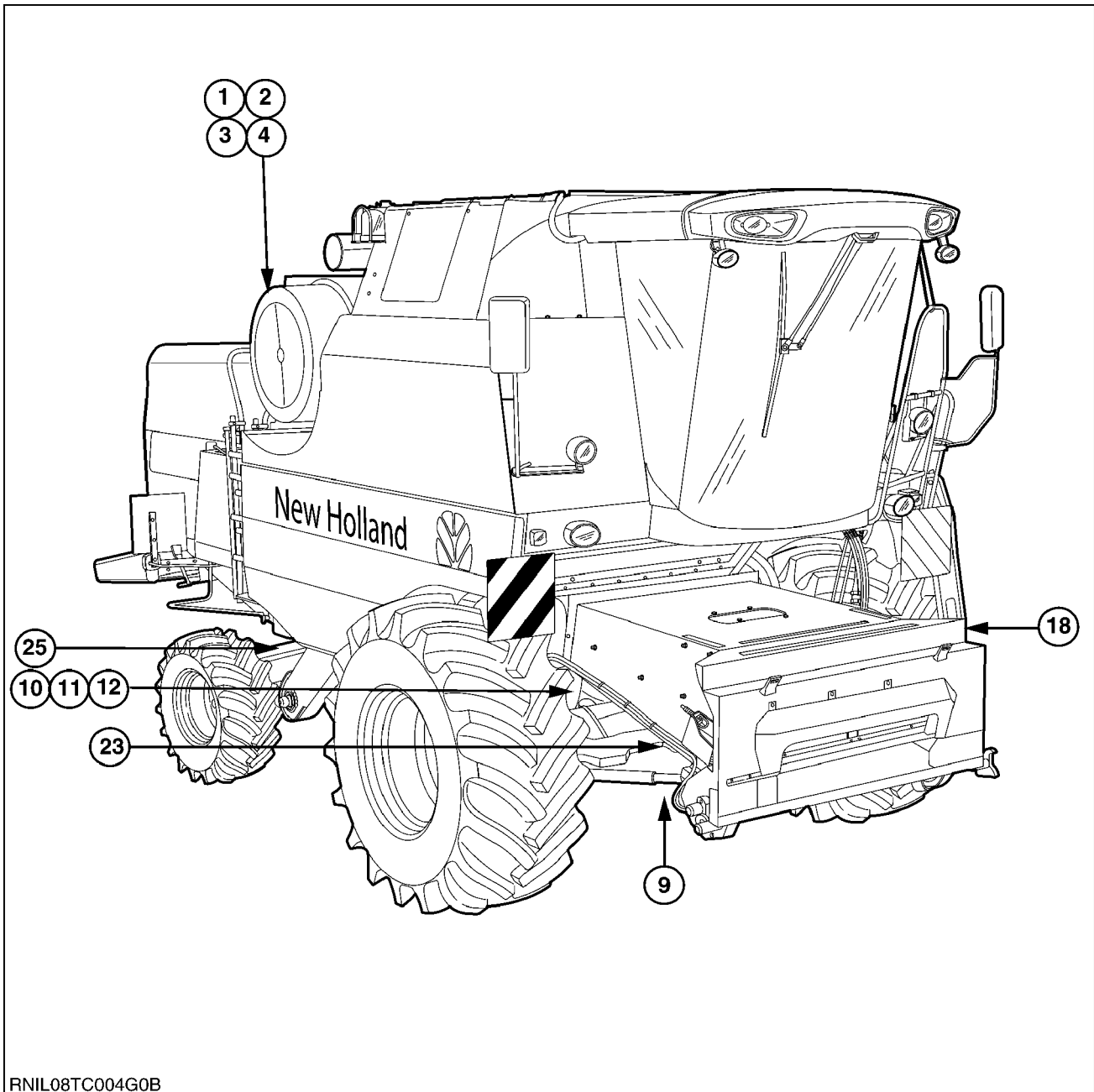

RNIL08TC004G0B

RNIL08TC004G0B 1

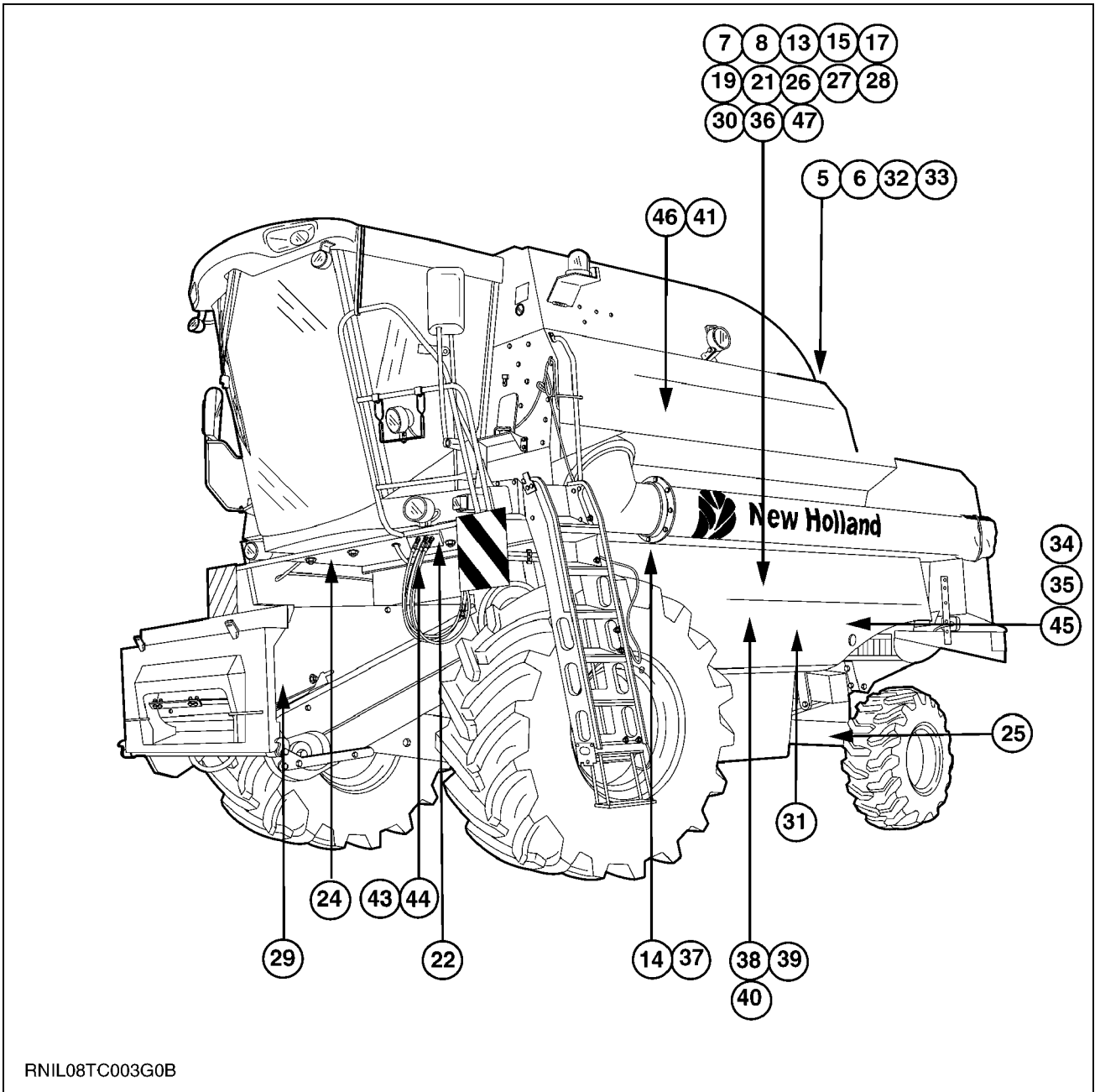

RNIL08TC003G0B

## PRIMARY HYDRAULIC POWER SYSTEM - Component localisation

TC5000

**NOTE:** To find the location of those components, refer to **PRIMARY HYDRAULIC POWER SYSTEM - Overview (A.10.A)**.

### For units without lateral flotation:

Main hydraulic pump (2), steering circuit pump (3).

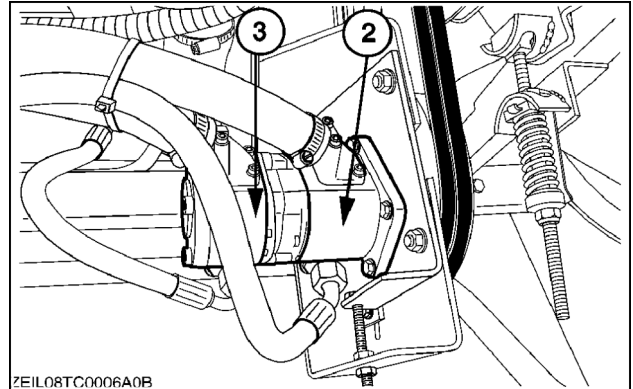

ZEIL08TC0006A0B 1

### For units with lateral flotation (optional):

Main hydraulic pump (2), steering circuit pump (3), lateral flotation pump (4).

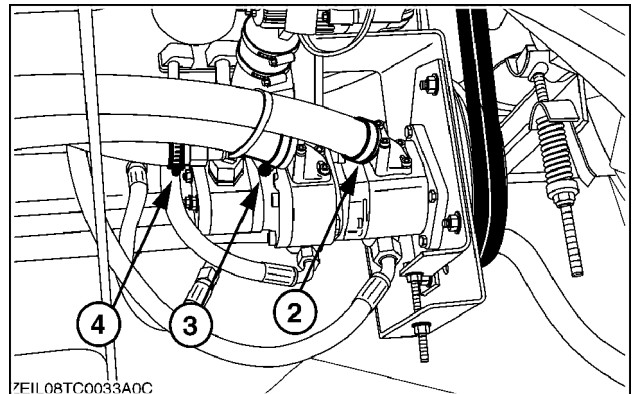

ZEIL08TC0033A0C 2

Oil tank (5), filler cap with filter (6), breather with filter and non-return valve (33), low pressure filter (32).

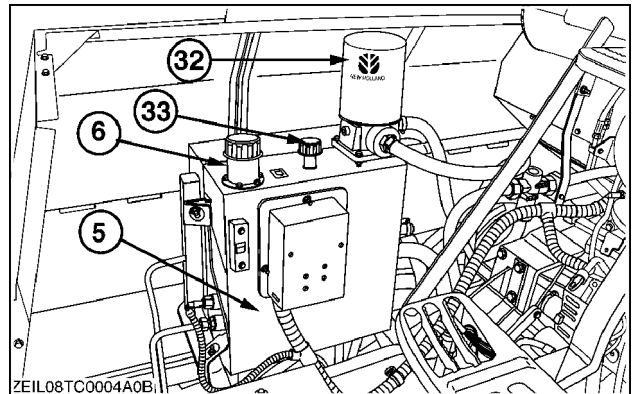

ZEIL08TC0004A0B 3



**Suggest:**

**If the above button click is invalid.**

**Please download this document**

**first, and then click the above link**

**to download the complete manual.**

**Thank you so much for reading**

**Valve stack**

**Hydrostatic drive unit without lateral flotation:**

Header height control valve (8), pilot valve (42), unloading tube valve (13), reel vertical adjustment valve (15), reel horizontal adjustment valve (17).

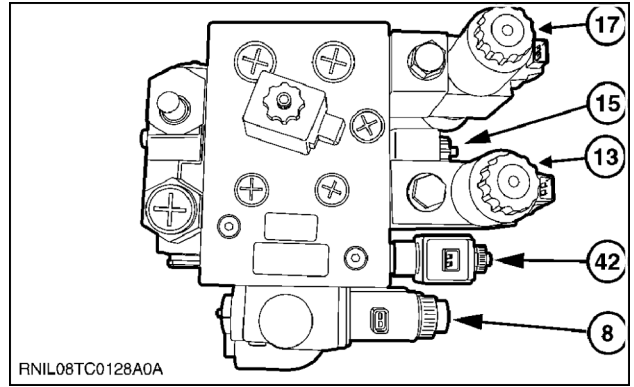

RNIL08TC0128A0A 4

**Hydrostatic drive with lateral flotation:**

Header height control valve (8), pilot valve (42), unloading tube control valve (13), reel vertical adjustment valve (15), reel horizontal adjustment valve (17), lateral flotation control valve (28), load sensing valve (27).

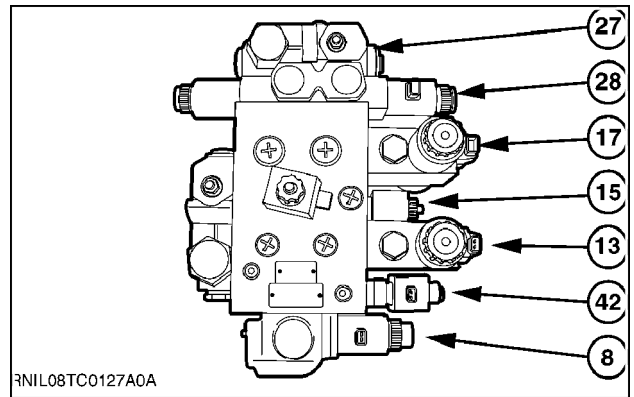

RNIL08TC0127A0A 5

**Mechanical drive unit without lateral flotation:**

Header height control valve (8), pilot valve (42), unloading tube valve (13), reel vertical adjustment valve (15), reel horizontal adjustment valve (17), drive variator valve (47).

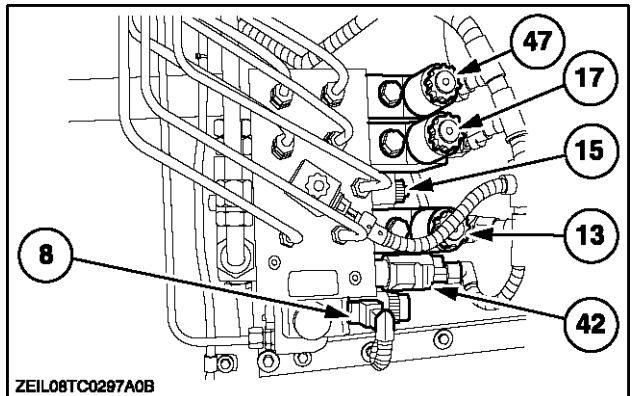

ZEIL08TC0297A0B 6

Header lift cylinders (9).

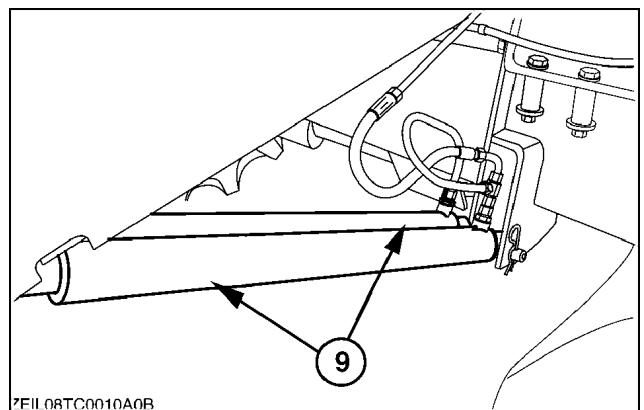

ZEIL08TC0010A0B 7

**<https://www.ebooklibonline.com>**

Hello dear friend!

Thank you very much for reading.

Enter the link into your browser.

The full manual is available for immediate download.

**<https://www.ebooklibonline.com>**