

SERVICE MANUAL

T7.220 / T7.235 / T7.250 / T7.260 / T7.270 Auto Command
T7.220 / T7.235 / T7.250 / T7.260 Power Command
Tractor

Part number 47524331

English
May 2013





SERVICE MANUAL



**T7.220 AutoCommand , T7.220 Power Command , T7.235 AutoCommand ,
T7.235 Power Command , T7.250 AutoCommand , T7.250 Power Command ,
T7.260 AutoCommand , T7.260 Power Command , T7.270 AutoCommand**

Link Product / Engine

Product	Market Product	Engine
T7.220 Power Command	Europe	F4DFE613L*A
T7.220 Power Command	North America	F4DFE613L*A
T7.220 Power Command	International Region	F4DFE613L*A
T7.235 Power Command	Europe	F4DFE613K*A
T7.235 Power Command	International Region	F4DFE613K*A
T7.235 Power Command	North America	F4DFE613K*A
T7.250 Power Command	North America	F4DFE613J*A
T7.250 Power Command	International Region	F4DFE613J*A
T7.250 Power Command	Europe	F4DFE613J*A
T7.260 Power Command	North America	F4DFE613H*A
T7.260 Power Command	Europe	F4DFE613H*A
T7.260 Power Command	International Region	F4DFE613H*A
T7.220 AutoCommand	Europe	F4DFE613L*A
T7.220 AutoCommand	International Region	F4DFE613L*A
T7.235 AutoCommand	International Region	F4DFE613K*A
T7.235 AutoCommand	Europe	F4DFE613K*A
T7.235 AutoCommand	North America	F4DFE613K*A
T7.250 AutoCommand	North America	F4DFE613J*A
T7.250 AutoCommand	Europe	F4DFE613J*A
T7.250 AutoCommand	International Region	F4DFE613J*A
T7.260 AutoCommand	Europe	F4DFE613H*A
T7.260 AutoCommand	North America	F4DFE613H*A
T7.260 AutoCommand	International Region	F4DFE613H*A
T7.270 AutoCommand	North America	F4DFE613G*A
T7.270 AutoCommand	International Region	F4DFE613G*A
T7.270 AutoCommand	Europe	F4DFE613G*A

<https://www.ebooklibonline.com>

Hello dear friend!

Thank you very much for reading.

Enter the link into your browser.

The full manual is available for immediate download.

<https://www.ebooklibonline.com>

Contents

INTRODUCTION

Engine.....	10
[10.001] Engine and crankcase	10.1
[10.102] Pan and covers	10.2
[10.216] Fuel tanks	10.3
[10.210] Lift pump and lines	10.4
[10.218] Fuel injection system.....	10.5
[10.250] Turbocharger and lines.....	10.6
[10.254] Intake and exhaust manifolds and muffler	10.7
[10.500] Selective Catalytic Reduction (SCR) exhaust treatment.....	10.8
[10.400] Engine cooling system	10.9
[10.414] Fan and drive	10.10
[10.408] Oil cooler and lines.....	10.11
Transmission.....	21
[21.113] Powershift transmission	21.1
[21.155] Powershift transmission internal components.....	21.2
[21.160] Creeper	21.3
[21.166] Overdrive.....	21.4
[21.504] Continuously Variable Transmission (CVT)	21.5
[21.505] Continuously Variable Transmission (CVT) external controls.....	21.6
[21.506] Continuously Variable Transmission (CVT) lubrication system	21.7
[21.507] Continuously Variable Transmission (CVT) internal components	21.8
[21.109] Transmission cooler and lines.....	21.9
Four-Wheel Drive (4WD) system	23
[23.202] Electro-hydraulic control	23.1
[23.314] Drive shaft.....	23.2
Front axle system	25

[25.100] Powered front axle	25.1
[25.102] Front bevel gear set and differential	25.2
[25.108] Final drive hub, steering knuckles, and shafts	25.3
[25.122] Axle suspension control	25.4
Rear axle system.....	27
[27.100] Powered rear axle.....	27.1
[27.106] Rear bevel gear set and differential	27.2
[27.120] Planetary and final drives	27.3
Power Take-Off (PTO).....	31
[31.101] Rear mechanical control	31.1
[31.104] Rear electro-hydraulic control.....	31.2
[31.114] Two-speed rear Power Take-Off (PTO)	31.3
[31.116] Three-speed rear Power Take-Off (PTO)	31.4
[31.119] Four-speed rear Power Take-Off (PTO).....	31.5
[31.146] Front Power Take-Off (PTO)	31.6
Brakes and controls	33
[33.202] Hydraulic service brakes	33.1
[33.110] Parking brake or parking lock	33.2
[33.220] Trailer brake hydraulic control.....	33.3
[33.224] Trailer brake pneumatic control	33.4
[33.350] Anti-lock Brake System (ABS)	33.5
Hydraulic systems.....	35
[35.000] Hydraulic systems.....	35.1
[35.300] Reservoir, cooler, and filters.....	35.2
[35.106] Variable displacement pump	35.3
[35.102] Pump control valves.....	35.4
[35.105] Charge pump.....	35.5
[35.322] Regulated/Low pressure system	35.6

[35.204] Remote control valves	35.7
[35.220] Auxiliary hydraulic pump and lines	35.8
[35.114] Three-point hitch control valve	35.9
[35.160] Front hitch controls and lines	35.10
[35.162] Front hitch cylinders and lines	35.11
Pneumatic system	36
[36.100] Pneumatic system.....	36.1
Hitches, drawbars, and implement couplings.....	37
[37.120] Rear three-point hitch linkage.....	37.1
[37.162] Front hitch.....	37.2
[37.110] Rear three-point hitch	37.3
[37.106] Automatic pickup hitch	37.4
Frames and ballasting	39
[39.100] Frame	39.1
Steering.....	41
[41.101] Steering control	41.1
[41.106] Tie rods.....	41.2
[41.200] Hydraulic control components.....	41.3
[41.216] Cylinders	41.4
[41.432] Autoguidance steering	41.5
Wheels.....	44
[44.511] Front wheels.....	44.1
[44.520] Rear wheels.....	44.2
Cab climate control	50
[50.100] Heating	50.1
[50.104] Ventilation	50.2
[50.200] Air conditioning.....	50.3
Electrical systems	55

- [55.610] Ground speed control 55.1
- [55.000] Electrical system 55.2
- [55.100] Harnesses and connectors..... 55.3
- [55.015] Engine control system..... 55.4
- [55.301] Alternator..... 55.5
- [55.302] Battery..... 55.6
- [55.988] Selective Catalytic Reduction (SCR) electrical system 55.7
- [55.640] Electronic modules..... 55.8
- [55.513] Cab transmission controls..... 55.9
- [55.024] Transmission control system..... 55.10
- [55.020] Transmission speed sensors..... 55.11
- [55.021] Transmission pressure sensors 55.12
- [55.022] Transmission temperature sensors 55.13
- [55.045] Front axle control system 55.14
- [55.048] Rear Power Take-Off (PTO) control system 55.15
- [55.049] Front Power Take-Off (PTO) control system 55.16
- [55.031] Parking brake electrical system 55.17
- [55.035] Remote control valve electric control 55.18
- [55.051] Cab Heating, Ventilation, and Air-Conditioning (HVAC) controls..... 55.19
- [55.050] Heating, Ventilation, and Air-Conditioning (HVAC) control system..... 55.20
- [55.047] Steering control system 55.21
- [55.523] Cab hitch controls 55.22
- [55.130] Rear three-point hitch electronic control system 55.23
- [55.911] Global Positioning System (GPS) 55.24
- [55.680] Autopilot/Autoguidance 55.25
- [55.408] Warning indicators, alarms, and instruments 55.26
- [55.350] Anti-lock Brake System (ABS) electrical system..... 55.27
- [55.032] Trailer brake electrical system 55.28
- [55.030] Service brake electrical system 55.29

[55.DTC] FAULT CODES.....	55.30
Platform, cab, bodywork, and decals.....	90
[90.100] Engine hood and panels	90.1
[90.150] Cab.....	90.2



INTRODUCTION

Contents

INTRODUCTION

Advice - Important notice regarding equipment servicing	3
Foreword - How to use and navigate through this manual	4
Safety rules	9
Safety rules	10
Torque - Minimum tightening torques for normal assembly	12
Torque - Standard torque data for hydraulics	17
General specification - Biodiesel Fuels	19
Capacities	20
<small>T7.220-270 AutoCommand, T7.220-260 Power Command</small>	
Consumables Lubrications and Coolants	21

Advice - Important notice regarding equipment servicing

All repair and maintenance work listed in this manual must be carried out only by qualified dealership personnel, strictly complying with the instructions given, and using, whenever possible, the special tools.

Anyone who performs repair and maintenance operations without complying with the procedures provided herein shall be responsible for any subsequent damages.

The manufacturer and all the organizations of its distribution chain, including - without limitation - national, regional, or local dealers, reject any responsibility for damages caused by parts and/or components not approved by the manufacturer, including those used for the servicing or repair of the product manufactured or marketed by the manufacturer. In any case, no warranty is given or attributed on the product manufactured or marketed by the manufacturer in case of damages caused by parts and/or components not approved by the manufacturer.

The information in this manual is up-to-date at the date of the publication. It is the policy of the manufacturer for continuous improvement. Some information could not be updated due to modifications of a technical or commercial type, or changes to the laws and regulations of different countries.

In case of questions, refer to your Sales and Service Networks.

Foreword - How to use and navigate through this manual

This manual has been produced by a new technical information system. This new system is designed to deliver technical information electronically through web delivery (eTIM), DVD, and paper manuals. A coding system called SAP has been developed to link the technical information to other Product Support functions, e.g., Warranty.

Technical information is written to support the maintenance and service of the functions or systems on a customer's machine. When a customer has a concern on their machine it is usually because a function or system on their machine is not working at all, is not working efficiently, or is not responding correctly to their commands. When you refer to the technical information in this manual to resolve that customer's concern, you will find all the information classified using the SAP coding, according to the functions or systems on that machine. Once you have located the technical information for that function or system, you will then find all the mechanical, electrical or hydraulic devices, components, assemblies, and sub assemblies for that function or system. You will also find all the types of information that have been written for that function or system: the technical data (specifications), the functional data (how it works), the diagnostic data (fault codes and troubleshooting), and the service data (remove, install adjust, etc.).

By integrating SAP coding into technical information, you will be able to search and retrieve just the right piece of technical information you need to resolve that customer's concern on his machine. This is made possible by attaching 3 categories to each piece of technical information during the authoring process.

The first category is the Location, the second category is the Information Type and the third category is the Product:

- LOCATION - the component or function on the machine, that the piece of technical information is going to describe (e.g., Fuel tank).
- INFORMATION TYPE - the piece of technical information that has been written for a particular component or function on the machine (e.g., Capacity would be a type of Technical Data describing the amount of fuel held by the fuel tank).
- PRODUCT - the model for which the piece of technical information is written.

Every piece of technical information will have those three categories attached to it. You will be able to use any combination of those categories to find the right piece of technical information you need to resolve that customer's concern on their machine.

That information could be:

- the procedure for how to remove the cylinder head
- a table of specifications for a hydraulic pump
- a fault code
- a troubleshooting table
- a special tool



SERVICE MANUAL

Engine



**T7.220 AutoCommand , T7.220 Power Command , T7.235 AutoCommand ,
T7.235 Power Command , T7.250 AutoCommand , T7.250 Power Command ,
T7.260 AutoCommand , T7.260 Power Command , T7.270 AutoCommand**

Engine - Disconnect

Prior operation:

Remove the battery, for further information refer to **Battery - Remove (55.302)**

Prior operation:

Drain the engine coolant, for further information refer to **Engine cooling system - Drain fluid (10.400)**

Prior operation:

Discharge the air conditioning system, for further information refer to **Air conditioning - Discharging (50.200)**

Prior operation:

Remove the selective catalytic reduction (SCR) exhaust line, for further information refer to **Exhaust pipes - Remove (10.254)**

Prior operation:

Remove the front AoH converter, for further information refer to **Air-over-Hydraulic (AoH) converter - Remove (33.350)**

Prior operation:

Remove the front wheels, for further information refer to **Front wheels - Remove (44.511)**

⚠ WARNING

Heavy objects!

Lift and handle all heavy components using lifting equipment with adequate capacity. Always support units or parts with suitable slings or hooks. Make sure the work area is clear of all bystanders.

Failure to comply could result in death or serious injury.

W0398A

⚠ WARNING

Avoid injury!

Handle all parts carefully. Do not place your hands or fingers between parts. Use Personal Protective Equipment (PPE) as indicated in this manual, including protective goggles, gloves, and safety footwear.

Failure to comply could result in death or serious injury.

W0208A

1. Using suitable lifting equipment support the front weights.

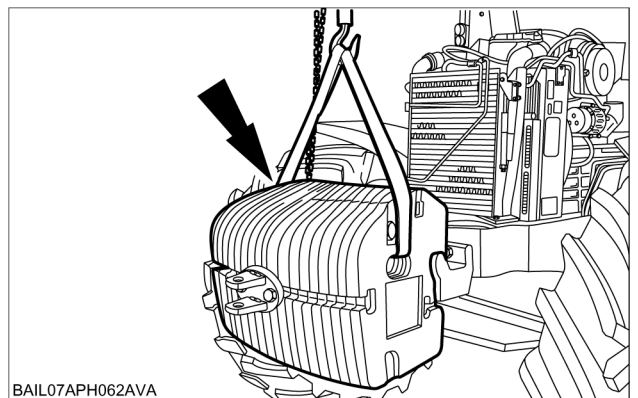

BAIL07APH062AVA

BAIL07APH062AVA 1

2. Disconnect and remove the front weights from the weight carrier.

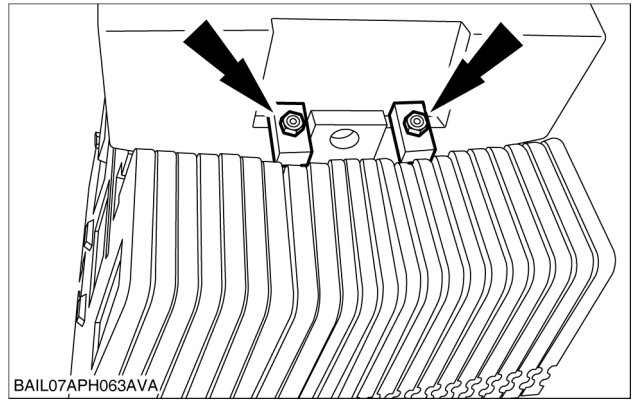

BAIL07APH063AVA 2

3. Disconnect the air conditioning hoses (1) and detach the bracket (2).

NOTE: Cap all open connections to prevent contamination of the system.

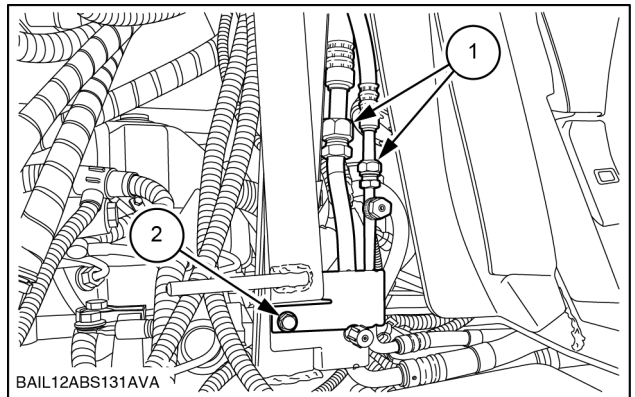

BAIL12ABS131AVA 3

4. Detach the air conditioning pipe bracket from the engine frame.

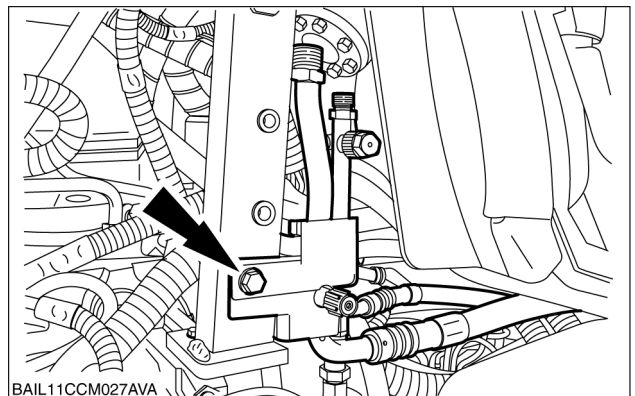

BAIL11CCM027AVA 4

5. Remove the front AoH bracket lower bolts.

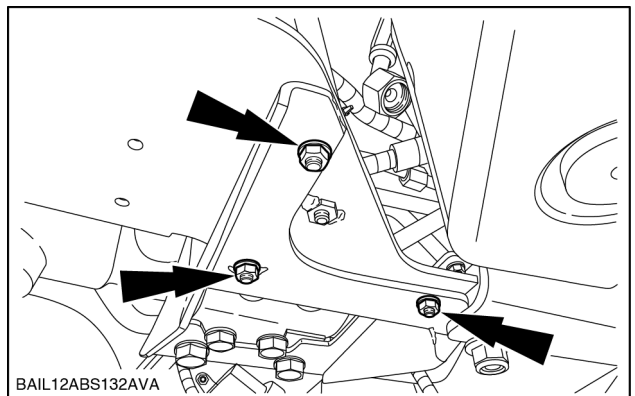

BAIL12ABS132AVA 5

6. Detach the pipe bracket and remove the AoH bracket.

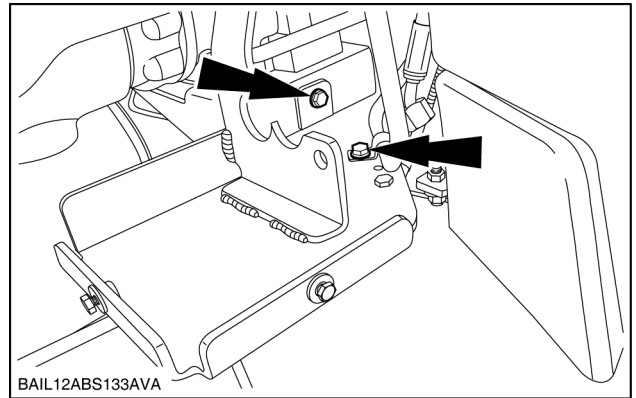

BAIL12ABS133AVA 6

7. Disconnect the brake valve supply hose (if fitted).

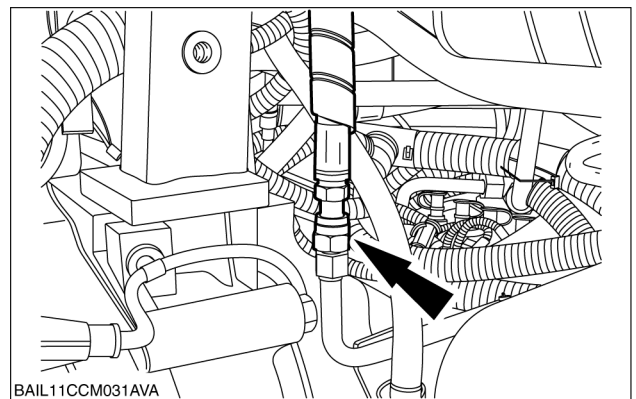

BAIL11CCM031AVA 7

8. Disconnect the flywheel position sensor electrical connector.

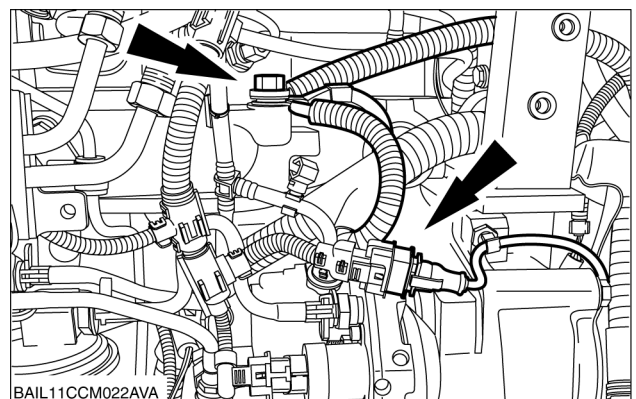

BAIL11CCM022AVA 8

9. Disconnect the steering hoses.

NOTE: Make a note of the position of the hoses to aid installation.

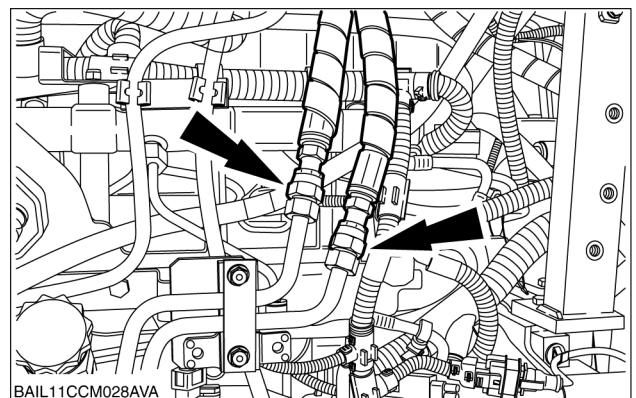

BAIL11CCM028AVA 9



Suggest:

If the above button click is invalid.

Please download this document

first, and then click the above link

to download the complete manual.

Thank you so much for reading

10. Disconnect the fuel supply and return lines.

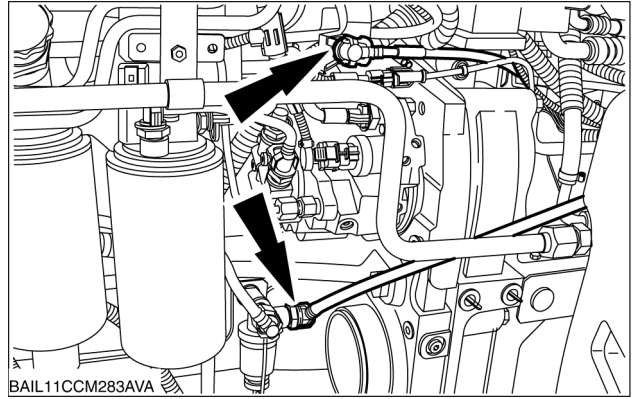

BAIL11CCM283AVA 10

11. Disconnect the diff lock and suspension pipes.

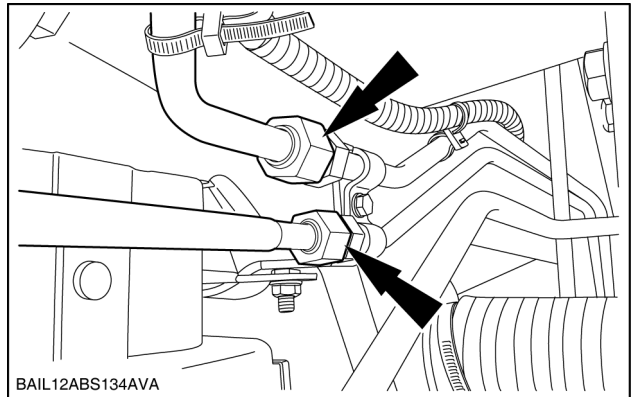

BAIL12ABS134AVA 11

12. Disconnect the trailer brake air supply pipe.

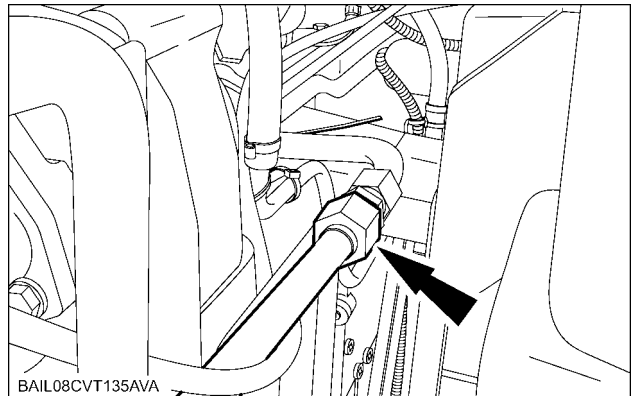

BAIL08CVT135AVA 12

13. Disconnect the heater supply hose from the rear of the engine cylinder head.

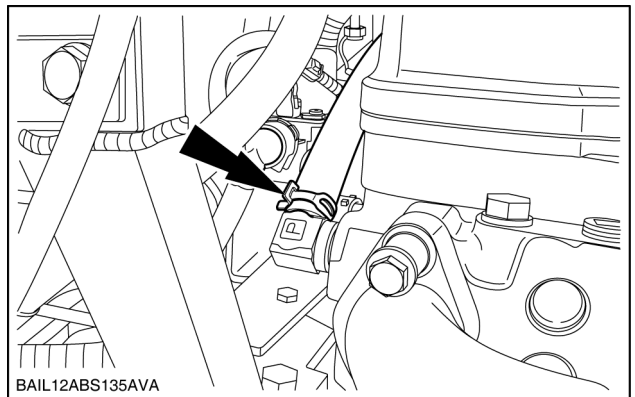

BAIL12ABS135AVA 13

<https://www.ebooklibonline.com>

Hello dear friend!

Thank you very much for reading.

Enter the link into your browser.

The full manual is available for immediate download.

<https://www.ebooklibonline.com>