

SERVICE MANUAL

T7.170 / T7.185 / T7.200 / T7.210

Auto Command Tractors

T7.170 / T7.185 / T7.200 / T7.210

Range Command / Power Command Tractors

1/4

Print No. 84477609A





SERVICE MANUAL



**T7.170 AutoCommand , T7.170 Power Command , T7.170 Range Command ,
T7.185 AutoCommand , T7.185 Power Command , T7.185 Range Command ,
T7.200 AutoCommand , T7.200 Power Command , T7.200 Range Command ,
T7.210 AutoCommand , T7.210 Power Command , T7.210 Range Command**

Contents

INTRODUCTION

HYDRAULIC, PNEUMATIC, ELECTRICAL, ELECTRONIC SYSTEMS A

PRIMARY HYDRAULIC POWER SYSTEM.....	A.10.A
PRIMARY HYDRAULIC POWER SYSTEM Closed center mechanical remote valve ...	A.10.B
PRIMARY HYDRAULIC POWER SYSTEM Electro-hydraulic remote valve.....	A.10.C
SECONDARY HYDRAULIC POWER SYSTEM.....	A.12.A
HYDRAULIC COMMAND SYSTEM.....	A.14.A
PNEUMATIC SYSTEM.....	A.20.A
ELECTRICAL POWER SYSTEM.....	A.30.A
ELECTRONIC SYSTEM.....	A.50.A
FAULT CODES.....	A.50.A

ENGINE AND PTO IN..... B

ENGINE.....	B.10.A
FUEL AND INJECTION SYSTEM.....	B.20.A
AIR INTAKE SYSTEM.....	B.30.A
EXHAUST SYSTEM.....	B.40.A
EXHAUST SYSTEM Emissions control.....	B.40.B
ENGINE COOLANT SYSTEM.....	B.50.A

TRANSMISSION, DRIVE AND PTO OUT..... C

TRANSMISSION Semi-Powershift.....	C.20.D
TRANSMISSION Powershift.....	C.20.E
TRANSMISSION Continuously Variable Transmission (CVT).....	C.20.G
ADDITIONAL REDUCERS Overdrive.....	C.30.D
REAR PTO Mechanical.....	C.40.B
REAR PTO Hydraulic.....	C.40.C
FRONT PTO Hydraulic.....	C.42.C

AXLES, BRAKES AND STEERING..... D

FRONT AXLE.....	D.10.A
REAR AXLE.....	D.12.A

<https://www.ebooklibonline.com>

Hello dear friend!

Thank you very much for reading.

Enter the link into your browser.

The full manual is available for immediate download.

<https://www.ebooklibonline.com>

2WD-4WD SYSTEM Hydraulic	D.14.C
STEERING Hydraulic.....	D.20.C
STEERING Autoguidance	D.20.E
SERVICE BRAKE Hydraulic.....	D.30.C
SERVICE BRAKE Pneumatic	D.30.E
PARKING BRAKE Mechanical	D.32.B
PARKING BRAKE Electronic.....	D.32.D
BRAKE CONNECTION Hydraulic.....	D.34.C
SUSPENSION Hydraulic	D.40.C
WHEELS AND TRACKS Wheels.....	D.50.C
FRAME AND CAB	E
FRAME Primary frame	E.10.B
SHIELD	E.20.A
USER CONTROLS AND SEAT	E.32.A
USER PLATFORM	E.34.A
ENVIRONMENT CONTROL Heating, ventilation and air-conditioning.....	E.40.D
HITCH AND WORKING TOOL	H
HITCH Front hitch	H.10.B
HITCH Rear hitch.....	H.10.C
HITCH Electronic draft control.....	H.10.D



INTRODUCTION

Contents

INTRODUCTION

Foreword	3
Foreword	4
Foreword Ecology and the Environment	9
Safety rules	10
Torque	14
Basic instructions	16
Conversion factors	18
Consumables Lubrications and Coolants	19
Capacities	22

Foreword

IMPORTANT INFORMATION

All repair and maintenance works listed in this manual must be carried out only by staff belonging to the NEW HOLLAND Service network, strictly complying with the instructions given and using, whenever required, the special tools.

Anyone who carries out the above operations without complying with the prescriptions shall be responsible for the subsequent damages.

The manufacturer and all the organizations of its distribution chain, including - without limitation - national, regional or local dealers, reject any responsibility for damages due to the anomalous behavior of parts and/or components not approved by the manufacturer himself, including those used for the servicing or repair of the product manufactured or marketed by the Manufacturer. In any case, no warranty is given or attributed on the product manufactured or marketed by the Manufacturer in case of damages due to an anomalous behavior of parts and/or components not approved by the Manufacturer.

No reproduction, though partial of text and illustrations allowed.

Foreword

Technical Information

This manual has been produced by a new technical information system. This new system is designed to deliver technical information electronically through Web delivery, DVD and in paper manuals. A coding system called ICE has been developed to link the technical information to other Product Support functions e.g. Warranty.

Technical information is written to support the maintenance and service of the functions or systems on a customers machine. When a customer has a concern on his machine it is usually because a function or system on his machine is not working at all, is not working efficiently, or is not responding correctly to his commands. When you refer to the technical information in this manual to resolve that customers concern, you will find all the information classified using the new ICE coding, according to the functions or systems on that machine. Once you have located the technical information for that function or system then you will find all the mechanical, electrical or hydraulic devices, components, assemblies and sub assemblies for that function or system. You will also find all the types of information that have been written for that function or system, the technical data (specifications), the functional data (how it works), the diagnostic data (fault codes and troubleshooting) and the service data (remove, install adjust, etc.).

By integrating this new ICE coding into technical information , you will be able to search and retrieve just the right piece of technical information you need to resolve that customers concern on his machine. This is made possible by attaching 3 categories to each piece of technical information during the authoring process.

The first category is the Location, the second category is the Information Type and the third category is the Product:

- LOCATION - is the component or function on the machine, that the piece of technical information is going to describe e.g. Fuel tank.
- INFORMATION TYPE - is the piece of technical information that has been written for a particular component or function on the machine e.g. Capacity would be a type of Technical Data that would describe the amount of fuel held by the Fuel tank.
- PRODUCT - is the model that the piece of technical information is written for.

Every piece of technical information will have those 3 categories attached to it. You will be able to use any combination of those categories to find the right piece of technical information you need to resolve that customers concern on his machine.

That information could be:

- the description of how to remove the cylinder head
- a table of specifications for a hydraulic pump
- a fault code
- a troubleshooting table
- a special tool

How to Use this Manual

This manual is divided into Sections. Each Section is then divided into Chapters. Contents pages are included at the beginning of the manual, then inside every Section and inside every Chapter. An alphabetical Index is included at the end of a Chapter. Page number references are included for every piece of technical information listed in the Chapter Contents or Chapter Index.

Each Chapter is divided into four Information types:

- Technical Data (specifications) for all the mechanical, electrical or hydraulic devices, components and assemblies.
- Functional Data (how it works) for all the mechanical, electrical or hydraulic devices, components and assemblies.
- Diagnostic Data (fault codes, electrical and hydraulic troubleshooting) for all the mechanical, electrical or hydraulic devices, components and assemblies.
- Service data (remove disassembly, assemble, install) for all the mechanical, electrical or hydraulic devices, components and assemblies.

Sections

Sections are grouped according to the main functions or a systems on the machine. Each Section is identified by a letter A, B, C etc. The amount of Sections included in the manual will depend on the type and function of the machine that the manual is written for. Each Section has a Contents page listed in alphabetic/numeric order. This table illustrates which Sections could be included in a manual for a particular product.

PRODUCT	SECTION										
	A - Hydraulic – Pneumatic – Electrical – Electronic Systems										
	B - Engine and PTO In										
	C - Transmission, Drive and PTO Out										
	D - Axles, Brakes and Steering										
	E - Frame and Cab										
	F - Frame Positioning										
	G - Tool Positioning										
	H - Hitch and Working Tool										
	J - Excavating and Landscaping										
K - Crop Processing											
L - Field Processing											
Tractors	X	X	X	X	X	X		X	X		
Vehicles with working arms: backhoes, excavators, skid steers,	X	X	X	X	X	X	X	X	X		
Combines, forage harvesters, balers,	X	X	X	X	X	X	X	X	X	X	
Seeding, planting, floating, spraying equipment,	X	X	X	X	X	X		X		X	
Mounted equipment and tools,					X	X	X		X		



SERVICE MANUAL

HYDRAULIC, PNEUMATIC, ELECTRICAL, ELECTRONIC SYSTEMS



**T7.170 AutoCommand , T7.170 Power Command , T7.170 Range Command ,
T7.185 AutoCommand , T7.185 Power Command , T7.185 Range Command ,
T7.200 AutoCommand , T7.200 Power Command , T7.200 Range Command ,
T7.210 AutoCommand , T7.210 Power Command , T7.210 Range Command**

Contents

HYDRAULIC, PNEUMATIC, ELECTRICAL, ELECTRONIC SYSTEMS - A

PRIMARY HYDRAULIC POWER SYSTEM	A.10.A
T7.170 AutoCommand , T7.170 Power Command , T7.170 Range Command , T7.185 AutoCommand , T7.185 Power Command , T7.185 Range Command , T7.200 AutoCommand , T7.200 Power Command , T7.200 Range Command , T7.210 AutoCommand , T7.210 Power Command , T7.210 Range Command	
PRIMARY HYDRAULIC POWER SYSTEM Closed center mechanical remote valve	A.10.B
T7.170 AutoCommand , T7.170 Power Command , T7.170 Range Command , T7.185 AutoCommand , T7.185 Power Command , T7.185 Range Command , T7.200 AutoCommand , T7.200 Power Command , T7.200 Range Command , T7.210 AutoCommand , T7.210 Power Command , T7.210 Range Command	
PRIMARY HYDRAULIC POWER SYSTEM Electro-hydraulic remote valve	A.10.C
T7.170 AutoCommand , T7.170 Power Command , T7.170 Range Command , T7.185 AutoCommand , T7.185 Power Command , T7.185 Range Command , T7.200 AutoCommand , T7.200 Power Command , T7.200 Range Command , T7.210 AutoCommand , T7.210 Power Command , T7.210 Range Command	
SECONDARY HYDRAULIC POWER SYSTEM	A.12.A
T7.170 AutoCommand , T7.170 Power Command , T7.170 Range Command , T7.185 AutoCommand , T7.185 Power Command , T7.185 Range Command , T7.200 AutoCommand , T7.200 Power Command , T7.200 Range Command , T7.210 AutoCommand , T7.210 Power Command , T7.210 Range Command	
HYDRAULIC COMMAND SYSTEM	A.14.A
T7.170 AutoCommand , T7.170 Power Command , T7.170 Range Command , T7.185 AutoCommand , T7.185 Power Command , T7.185 Range Command , T7.200 AutoCommand , T7.200 Power Command , T7.200 Range Command , T7.210 AutoCommand , T7.210 Power Command , T7.210 Range Command	
PNEUMATIC SYSTEM	A.20.A
T7.170 AutoCommand , T7.170 Power Command , T7.170 Range Command , T7.185 AutoCommand , T7.185 Power Command , T7.185 Range Command , T7.200 AutoCommand , T7.200 Power Command , T7.200 Range Command , T7.210 AutoCommand , T7.210 Power Command , T7.210 Range Command	
ELECTRICAL POWER SYSTEM	A.30.A
T7.170 AutoCommand , T7.170 Power Command , T7.170 Range Command , T7.185 AutoCommand , T7.185 Power Command , T7.185 Range Command , T7.200 AutoCommand , T7.200 Power Command , T7.200 Range Command , T7.210 AutoCommand , T7.210 Power Command , T7.210 Range Command	
ELECTRONIC SYSTEM	A.50.A
T7.170 AutoCommand , T7.170 Power Command , T7.170 Range Command , T7.185 AutoCommand , T7.185 Power Command , T7.185 Range Command , T7.200 AutoCommand , T7.200 Power Command , T7.200 Range Command , T7.210 AutoCommand , T7.210 Power Command , T7.210 Range Command	
FAULT CODES	A.50.A
T7.170 AutoCommand , T7.170 Power Command , T7.170 Range Command , T7.185 AutoCommand , T7.185 Power Command , T7.185 Range Command , T7.200 AutoCommand , T7.200 Power Command , T7.200 Range Command , T7.210 AutoCommand , T7.210 Power Command , T7.210 Range Command	



HYDRAULIC, PNEUMATIC, ELECTRICAL, ELECTRONIC SYSTEMS - A

PRIMARY HYDRAULIC POWER SYSTEM - 10.A

**T7.170 AutoCommand , T7.170 Power Command , T7.170 Range Command ,
T7.185 AutoCommand , T7.185 Power Command , T7.185 Range Command ,
T7.200 AutoCommand , T7.200 Power Command , T7.200 Range Command ,
T7.210 AutoCommand , T7.210 Power Command , T7.210 Range Command**

Contents

HYDRAULIC, PNEUMATIC, ELECTRICAL, ELECTRONIC SYSTEMS - A

PRIMARY HYDRAULIC POWER SYSTEM - 10.A

TECHNICAL DATA

Power beyond	
Torque	3
Hydraulic pump	
Variable displacement pump - General specification	4
Charge pump	
General specification	5

FUNCTIONAL DATA

PRIMARY HYDRAULIC POWER SYSTEM	
Static description	6
T7.170 Range Command, T7.170 Power Command, T7.185 Range Command, T7.185 Power Command, T7.200 Range Command, T7.200 Power Command, T7.210 Range Command, T7.210 Power Command	
Static description	17
T7.170 AutoCommand, T7.185 AutoCommand, T7.200 AutoCommand, T7.210 AutoCommand	
Hydraulic schema	31
T7.170 AutoCommand, T7.185 AutoCommand, T7.200 AutoCommand, T7.210 AutoCommand	
Power beyond	
Exploded view	35
Hydraulic pump	
Variable displacement pump - Dynamic description	36
Compensator	
Exploded view	38

SERVICE

PRIMARY HYDRAULIC POWER SYSTEM	
Test Using DATAR Equipment	39
Hydraulic pump	
Variable displacement pump - Overhaul	47
Variable displacement pump - Remove	51
Compensator	
Overhaul	54
Filter	
Replace	56

Power beyond - Torque

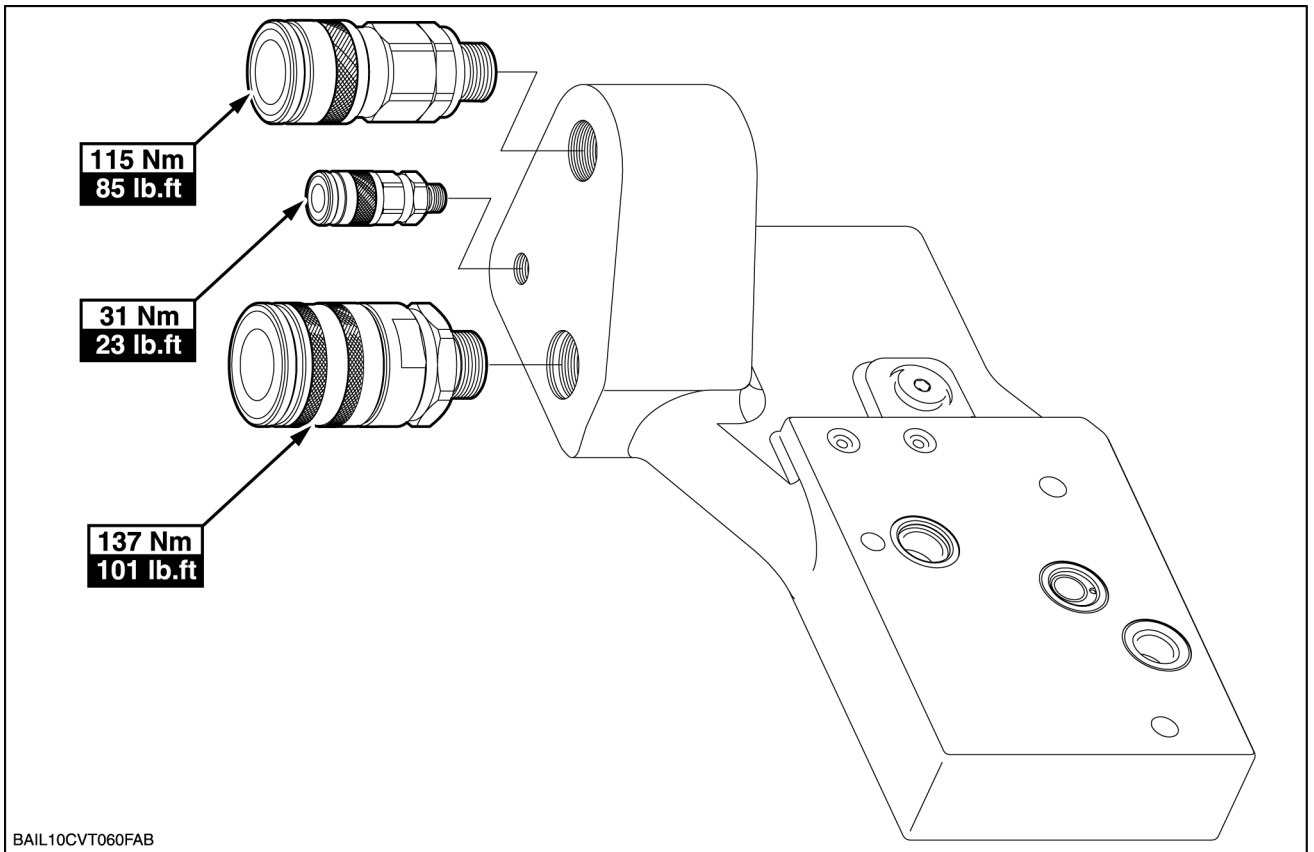

BAIL10CVT060FAB 1

Hydraulic pump Variable displacement pump - General specification

Variable displacement pump

Type	Variable Displacement Closed Centre Load Sensing Piston Pump
Rotation	Clockwise
Pump speed @ engine speed 2400 RPM maximum rated speed (Theoretical)	3000 RPM
Pump speed @ engine speed 2200 RPM	2750 RPM
Output @ engine speed 2200 RPM (Standard flow)	125 l/min (33.0 US gpm)
Output @ engine speed 2200 RPM (High flow)	140 l/min (37.0 US gpm)
Piston Pump displacement (Standard flow)	56 cm³/rev
Piston Pump displacement (High flow)	63 cm³/rev
Low Standby Pressure	26 bar (377.0 psi) ± 1 bar (14.5 psi)
Low Standby Pressure (with Italian trailer brakes)	36 bar (522.0 psi)
High Standby Pressure	210 bar (3045.00 psi) ± 5 bar (72.5 psi)
Maximum system pressure	245 bar (3552.5 psi)± 5 bar (72.5 psi)
Cooler By Pass valve	5.8 bar (84.1 psi).

Charge Pump

Type	Internal rotor gear pump
Charge Pump displacement	74 cm³/rev Standard flow 82 cm³/rev High flow
Output @ engine speed 2200 RPM Standard flow	200 l/min (52.8 US gpm)
Output @ engine speed 2200 RPM Hi flow	225 l/min (59.4 US gpm)
Charge pressure filter dump valve :	
Crack open	10 bar (145.0 psi)
Fully open	15 bar (217.5 psi)
Charge pressure	2 - 4 bar (29.0 - 58.0 psi)
Charge pressure switch closes	1 bar (14.5 psi)

Charge pump - General specification

Charge Pump

Type	Internal rotor gear pump
Charge Pump displacement	74 cm³/rev Standard flow 82 cm³/rev High flow
Output @ engine speed 2200 RPM Standard flow	250 l/min (66 US gpm)
Output @ engine speed 2200 RPM Hi flow	250 l/min (66 US gpm)
Charge pressure filter dump valve :	
Crack open	10 bar (145.0 psi)
Fully open	15 bar (217.5 psi)
Charge pressure	2 - 4 bar (29.0 - 58.0 psi)
Charge pressure switch closes	1 bar (14.5 psi)



Suggest:

If the above button click is invalid.

Please download this document

first, and then click the above link

to download the complete manual.

Thank you so much for reading

PRIMARY HYDRAULIC POWER SYSTEM - Static description

T7.170 Range Command, T7.170 Power Command, T7.185 Range Command, T7.185 Power Command, T7.200 Range Command, T7.200 Power Command, T7.210 Range Command, T7.210 Power Command

The hydraulic systems can be separated into the following circuits :-

High Pressure Circuit

Hydraulic Lift Assembly.

Remote Control Valves.

Trailer Brake (Where Fitted)
Suspended Front Axle.

Front Lift (Where fitted).

Steering Circuit

Steering Motor and Cylinders

Low Pressure Circuit

Independent Power Take Off (PTO).

Differential Lock

Front Wheel Drive engagement

Transmission clutch and synchroniser engagement

Creeper engagement (Where fitted)

Front PTO (Where fitted)

50 kph engagement (Where fitted)

Lubrication Circuit

PTO Clutch Plates

Transmission Clutch Plates.

Transmission Shaft Pressure Lube
Pump Drive Gear Bearing.

Hydraulic Lift Cross Shaft

Options/Configurations			
Hydraulic Pump/ HPL/ Remote Valve Options			
	Less Hydraulic Trailer Brakes	With Hydraulic Trailer Brakes	Hydraulic Trailer Brake Italy
	Variable Displacement Pump.		
	EDC		
Mechanical Remote Valves	2 Non Configurable 2 Configurable 1 Non Configurable + 2 Configurable 2 Non Configurable + 2 Configurable		

<https://www.ebooklibonline.com>

Hello dear friend!

Thank you very much for reading.

Enter the link into your browser.

The full manual is available for immediate download.

<https://www.ebooklibonline.com>