

SERVICE MANUAL

T4.85 / T4.95 / T4.105 / T4.115

With Hi-Lo Transmission

**With Mechanical or Power Shuttle Transmission
Tractor**

With Hi-Lo Transmission PIN ZxJT0xxxx and above

With Mechanical or Power Shuttle Transmission PIN ZxJT5xxxx and above

Part number 47840679

English

March 2015

Replaces part number 47561948





SERVICE MANUAL

T4.105 less cab, with hi-lo transmission [ZxJT0xxxx] , T4.105 less cab, with mechanical or power shuttle transmission [ZxJT5xxxx] , T4.105 with cab, with hi-lo transmission [ZxJT0xxxx] , T4.105 with cab, with mechanical or power shuttle transmission [ZxJT5xxxx] , T4.115 less cab, with hi-lo transmission [ZxJT0xxxx] , T4.115 less cab, with mechanical or power shuttle transmission [ZxJT5xxxx] , T4.115 with cab, with hi-lo transmission [ZxJT0xxxx] , T4.115 with cab, with mechanical or power shuttle transmission [ZxJT5xxxx] , T4.85 less cab, with hi-lo transmission [ZxJT0xxxx] , T4.85 less cab, with mechanical or power shuttle transmission [ZxJT5xxxx] , T4.85 with cab, with hi-lo transmission [ZxJT0xxxx] , T4.85 with cab, with mechanical or power shuttle transmission [ZxJT5xxxx] , T4.95 less cab, with hi-lo transmission [ZxJT0xxxx] , T4.95 less cab, with mechanical or power shuttle transmission [ZxJT5xxxx] , T4.95 with cab, with hi-lo transmission [ZxJT0xxxx] , T4.95 with cab, with mechanical or power shuttle transmission [ZxJT5xxxx]

Link Product / Engine

| Product | Market Product | Engine |
|--|----------------|----------------|
| T4.105 less cab, with mechanical or power shuttle transmission [ZxJT5xxxx] | North America | F5DFL413J*A002 |
| T4.105 with cab, with mechanical or power shuttle transmission [ZxJT5xxxx] | North America | F5DFL413J*A002 |
| T4.105 less cab, with hi-lo transmission [ZxJT0xxxx] | North America | F5DFL413L*A001 |
| T4.105 with cab, with hi-lo transmission [ZxJT0xxxx] | North America | F5DFL413L*A001 |
| T4.85 less cab, with mechanical or power shuttle transmission [ZxJT5xxxx] | North America | F5DFL413L*A002 |
| T4.85 with cab, with mechanical or power shuttle transmission [ZxJT5xxxx] | North America | F5DFL413L*A002 |
| T4.85 less cab, with hi-lo transmission [ZxJT0xxxx] | North America | F5DFL413J*A001 |
| T4.85 with cab, with hi-lo transmission [ZxJT0xxxx] | North America | F5DFL413J*A001 |
| T4.95 less cab, with mechanical or power shuttle transmission [ZxJT5xxxx] | North America | F5DFL413K*A002 |
| T4.95 with cab, with mechanical or power shuttle transmission [ZxJT5xxxx] | North America | F5DFL413K*A002 |
| T4.95 less cab, with hi-lo transmission [ZxJT0xxxx] | North America | F5DFL413K*A001 |
| T4.95 with cab, with hi-lo transmission [ZxJT0xxxx] | North America | F5DFL413K*A001 |

<https://www.ebooklibonline.com>

Hello dear friend!

Thank you very much for reading.

Enter the link into your browser.

The full manual is available for immediate download.

<https://www.ebooklibonline.com>

Contents

INTRODUCTION

| | |
|--|-------|
| Engine..... | 10 |
| [10.001] Engine and crankcase | 10.1 |
| [10.216] Fuel tanks | 10.2 |
| [10.501] Exhaust Gas Recirculation (EGR) - Diesel Particulate Filter (DPF) exhaust treatment | 10.3 |
| [10.400] Engine cooling system | 10.4 |
| [10.414] Fan and drive | 10.5 |
| [10.310] Aftercooler..... | 10.6 |
| Clutch | 18 |
| [18.100] Clutch mechanical release control | 18.1 |
| [18.104] Clutch hydraulic release control..... | 18.2 |
| [18.110] Clutch and components | 18.3 |
| Transmission..... | 21 |
| [21.130] Mechanical transmission external controls..... | 21.1 |
| [21.112] Power shuttle transmission..... | 21.2 |
| [21.110] Master clutch housing | 21.3 |
| [21.134] Power shuttle transmission external controls | 21.4 |
| [21.154] Power shuttle transmission internal components | 21.5 |
| [21.160] Creeper | 21.6 |
| [21.162] Reverser | 21.7 |
| [21.168] Hi-Lo unit..... | 21.8 |
| [21.109] Transmission cooler and lines..... | 21.9 |
| [21.118] Transmission/Rear drive | 21.10 |
| [21.148] Transmission/Rear drive internal components | 21.11 |
| [21.AAA] Transmission generic sub-group | 21.12 |
| Four-Wheel Drive (4WD) system | 23 |

| | |
|---|-----------|
| [23.101] Mechanical control | 23.1 |
| [23.202] Electro-hydraulic control | 23.2 |
| [23.314] Drive shaft..... | 23.3 |
| Front axle system | 25 |
| [25.100] Powered front axle | 25.1 |
| [25.102] Front bevel gear set and differential | 25.2 |
| [25.108] Final drive hub, steering knuckles, and shafts | 25.3 |
| [25.400] Non-powered front axle | 25.4 |
| Rear axle system..... | 27 |
| [27.106] Rear bevel gear set and differential..... | 27.1 |
| [27.120] Planetary and final drives | 27.2 |
| [27.100] Powered rear axle..... | 27.3 |
| Power Take-Off (PTO)..... | 31 |
| [31.101] Rear mechanical control | 31.1 |
| [31.104] Rear electro-hydraulic control..... | 31.2 |
| [31.110] One-speed rear Power Take-Off (PTO) | 31.3 |
| [31.114] Two-speed rear Power Take-Off (PTO) | 31.4 |
| [31.146] Front Power Take-Off (PTO) | 31.5 |
| Brakes and controls | 33 |
| [33.202] Hydraulic service brakes | 33.1 |
| [33.110] Parking brake or parking lock | 33.2 |
| Hydraulic systems..... | 35 |
| [35.000] Hydraulic systems..... | 35.1 |
| [35.104] Fixed displacement pump..... | 35.2 |
| [35.160] Front hitch controls and lines | 35.3 |
| [35.204] Remote control valves | 35.4 |
| [35.114] Three-point hitch control valve | 35.5 |
| [35.116] Three-point hitch cylinder | 35.6 |

| | |
|---|-----------|
| [35.701] Front loader arm hydraulic system | 35.7 |
| [35.723] Front loader bucket hydraulic system | 35.8 |
| Hitches, drawbars, and implement couplings..... | 37 |
| [37.100] Drawbars and towing hitches | 37.1 |
| [37.110] Rear three-point hitch | 37.2 |
| [37.120] Rear three-point hitch linkage..... | 37.3 |
| [37.162] Front hitch..... | 37.4 |
| [37.166] Front hitch linkage..... | 37.5 |
| Steering..... | 41 |
| [41.101] Steering control | 41.1 |
| [41.106] Tie rods..... | 41.2 |
| [41.200] Hydraulic control components..... | 41.3 |
| [41.206] Pump | 41.4 |
| [41.216] Cylinders | 41.5 |
| Wheels..... | 44 |
| [44.511] Front wheels..... | 44.1 |
| [44.520] Rear wheels | 44.2 |
| Cab climate control | 50 |
| [50.100] Heating | 50.1 |
| [50.104] Ventilation | 50.2 |
| [50.200] Air conditioning..... | 50.3 |
| Electrical systems | 55 |
| [55.100] Harnesses and connectors..... | 55.1 |
| [55.201] Engine starting system | 55.2 |
| [55.301] Alternator..... | 55.3 |
| [55.302] Battery..... | 55.4 |
| [55.640] Electronic modules | 55.5 |
| [55.048] Rear Power Take-Off (PTO) control system | 55.6 |

| | |
|--|-----------|
| [55.408] Warning indicators, alarms, and instruments | 55.7 |
| [55.DTC] FAULT CODES..... | 55.8 |
| Front loader and bucket..... | 82 |
| [82.100] Arm..... | 82.1 |
| [82.300] Bucket..... | 82.2 |
| [82.AAA] Front loader and bucket generic sub-group | 82.3 |
| Platform, cab, bodywork, and decals | 90 |
| [90.150] Cab..... | 90.1 |
| [90.151] Cab interior..... | 90.2 |
| [90.160] Cab interior trim and panels..... | 90.3 |
| [90.154] Cab doors and hatches | 90.4 |
| [90.110] Operator platform less cab | 90.5 |
| [90.100] Engine hood and panels | 90.6 |
| [90.102] Engine shields, hood latches, and trims | 90.7 |



INTRODUCTION

Safety rules SAFETY REGULATIONS

TO PREVENT ACCIDENTS

Most accidents or injuries that occur in workshops are the result of non-observance of simple and fundamental safety regulations.

For this reason, IN MOST CASES THESE ACCIDENTS CAN BE AVOIDED: by foreseeing possible causes and consequently acting with the necessary caution and care.

Accidents may occur with all types of vehicle, regardless of how well it was designed and built.

A careful and judicious service technician is the best guarantee against accidents.

Precise observance of the most basic safety rule is normally sufficient to avoid many serious accidents.

DANGER: Never carry out any cleaning, lubrication or maintenance operations when the engine is running.

GENERAL

- Carefully follow specified repair and maintenance procedures.
- Do not wear rings, wristwatches, jewellery, unbuttoned or loose articles of clothing such as: ties, torn clothing, scarves, open jackets or shirts with open zips that may remain entangled in moving parts.
It is advised to wear approved safety clothing, e.g: non-slip footwear, gloves, safety goggles, helmets, etc.
- Do not carry out repair operations with someone sitting in the driver's seat, unless the person is a trained technician who is assisting with the operation in question.
- Operate the vehicle and use the implements exclusively from the driver's seat.
- Do not carry out operations on the vehicle with the engine running, unless specifically indicated.
- Stop the engine and ensure that all pressure is relieved from hydraulic circuits before removing caps, covers, valves, etc.
- All repair and maintenance operations must be carried out using extreme care and attention.
- Service steps and platforms used in a workshop or in the field should be built in compliance with the safety rules in force.
- Disconnect the batteries and label all controls to indicate that the vehicle is being serviced. Block the machine and all equipment which should be raised.
- Do not check or fill fuel tanks, accumulator batteries, nor use starting liquid when smoking or near naked flames, as these fluids are inflammable.
- Brakes are inoperative if manually released for repair or maintenance purposes.
In such cases, the machine should be kept constantly under control using blocks or similar devices.
- The fuel nozzle should always be in contact with the filling aperture. Maintain this position until filling operations are completed in order to avoid possible sparks caused by the accumulation of static electricity.
- Only use specified towing points for towing the tractor, connect parts carefully. Make sure that all pins and/or locks are secured in position before applying traction.
Never remain near the towing bars, cables or chains that are operating under load
- Transport vehicles that cannot be driven using a trailer or a low-loading platform trolley, if available.
- When loading or unloading the vehicle from the trailer (or other means of transport), select a flat area capable of sustaining the trailer or truck wheels, firmly secure the tractor to the truck or trailer and lock the wheels in the position.
- Electric heaters, battery-chargers and similar equipment must only be powered by auxiliary power supplies with efficient ground insulation to avoid electrical shock hazards.
- Always use suitable hoisting or lifting devices when raising or moving heavy parts.
- Take extra care if bystanders are present.
- Never pour gasoline or diesel oil into open, wide and low containers.
- Never use gasoline, diesel oil or other inflammable liquids as cleaning agents. Use non-flammable non-toxic proprietary solvents.
- Wear safety goggles with side guards when cleaning parts with compressed air.
- Limit the air pressure to a maximum of **2.1 bar (30.5 psi)**, according to local regulations.

INTRODUCTION

- Do not run the engine in confined spaces without suitable ventilation.
- Do not smoke, use naked flames, or cause sparks in the area when fuel filling or handling highly inflammable liquids.
- Never use naked flames for lighting when working on the machine or checking for leaks.
- All movements must be carried out carefully when working under, on or near the vehicle and wear protective equipment: helmets, goggles and special footwear.
- When carrying out checks with the engine running, request the assistance of an operator in the driver's seat. The operator must maintain visual contact with the service technician at all times.
- If operating outside the workshop, position the vehicle on a flat surface and lock in position. If working on a slope, lock the vehicle in position and move to a flat area as soon as is safely possible.
- Damaged or bent chains or cables are unreliable. Do not use them for lifting or towing. Always use suitable protective gloves when handling chains or cables.
- Chains should always be safely secured. Ensure that fastening device is strong enough to hold the load foreseen. No persons should stop near the fastening point, trailing chains or cables.
- Maintenance and repair operations must be carried out in a CLEAN and DRY area, eliminate any water or oil spillage immediately.
- Do not create piles of oil or grease--soaked rags as they represent a serious fire hazard; store them in a closed metal container.
Before starting the vehicle or implements, make sure that the driver's seat is locked in position and always check that the area is free of persons or obstacles.
- Empty pockets of all objects that may fall unobserved into the vehicle parts when disassembled.
- In the presence of protruding metal parts, use protective goggles or goggles with side guards, helmets, special footwear and gloves.
- Handle all parts carefully, do not put your hands or fingers between moving parts, wear suitable safety clothing -- safety goggles, gloves and shoes.

WELDING OPERATIONS

- When welding, use protective safety devices: tinted safety goggles, helmets, special overalls, gloves and footwear. All persons present in the area where welding is taking place must wear tinted goggles.
NEVER LOOK AT THE WELDING ARC IF YOUR EYES ARE NOT SUITABLY PROTECTED.
- Where possible, remove the part or tool that requires arc welding from the tractor.
- Disconnect both battery leads. Isolate the cable ends to avoid contact with each other and the tractor.
- Position the welder ground clamp as near as possible to the area where welding is taking place.
- Remove the electronic control units located on the tractor if welding is to be carried out near these control units.
- Never allow welding cables to lay on, near or across any electrical wiring or electronic component while welding is in progress.
- Metal cables tend to fray with repeated use. Always use suitable protective devices (gloves, goggles, etc.) when handling cables.

START UP

- Never start the engine in confined spaces that are not equipped with adequate ventilation for exhaust gas extraction.
- Never place the head, body, limbs, feet, hands or fingers near fans or rotating belts.

ENGINE

- Always loosen the radiator cap slowly before removing it to allow any remaining pressure in the system to be discharged. Coolant should be topped up only when the engine is stopped or idle if hot.
- Never fill up with fuel when the engine is running, especially if hot, in order to prevent the outbreak of fire as a result of fuel spillage
- Never check or adjust fan belt tension when the engine is running.
Never adjust the fuel injection pump when the vehicle is moving.

- Never lubricate the vehicle when the engine is running.

ELECTRICAL SYSTEMS

- If it is necessary to use auxiliary batteries, remember that both ends of the cables must be connected as follows: (+) with (+) and (-) with (-).
- Avoid short-circuiting the terminals. **GAS RELEASED FROM BATTERIES IS HIGHLY INFLAMMABLE.**
- During charging, leave the battery compartment uncovered to improve ventilation.
- Never check the battery charge using "jumpers" (metal objects placed on the terminals).
- Avoid sparks or flames near the battery zone to prevent explosion hazards.
- Before servicing operations, check for fuel or current leaks. Eliminate any eventual leaks before starting work.
- Never charge batteries in confined spaces. Make sure that there is adequate ventilation in order to prevent accidental explosion hazards as a result of the accumulation of gases released during charging operations.
- Always disconnect the battery before performing any kind of servicing on the electrical system.

HYDRAULIC SYSTEMS

- Some fluid slowly coming out from a very small port can be almost invisible and be strong enough to penetrate the skin. Check for leaks using a piece of cardboard, **NEVER USE HANDS.**
- If any liquid penetrates skin tissue, call for medical aid immediately
- Serious skin infections may result if medical attention is not given.
- Use the specific tools when checking pressure values on the hydraulic system.

WHEELS AND TYRES

- Check that the tyres are correctly inflated at the pressure specified by the manufacturer. Periodically check possible damages to the rims and tyres.
- Stand away from (at the side of) the tire when checking inflation pressure.
- Only check pressure when the vehicle is unloaded and the tires are cold, to avoid incorrect readings as a result of over--pressure.
- Do not re--use parts of recovered wheels as incorrect welding or brazing may heat the material, causing it to weaken and eventually damage or break the wheel.
- Never cut, nor weld a rim with the inflated tyre assembled.
- When removing the wheels, lock both the front and rear vehicle wheels.
- Always position support stands when raising the vehicle, in order to conform to current safety regulations.
- Deflate the tyre before removing any object caught into the tyre tread.
- Never inflate tires using inflammable gases; this could cause an explosion and put operator safety at risk.

REMOVAL AND RE-FITTING

- Lift and handle all heavy parts using suitable lifting equipment and make sure that all slings and hooks are correctly secured.
- Handle all parts carefully during lifting operations, keep an eye on the personnel working near the load to be lifted. Never insert hands or fingers between parts, always wear approved accident prevention clothing (goggles, gloves and work boots).
- Avoid twisting chains or metal cables and always wear safety gloves when handling cables or chains.



SERVICE MANUAL

Engine

T4.105 less cab, with hi-lo transmission [ZxJT0xxxx] , T4.105 less cab, with mechanical or power shuttle transmission [ZxJT5xxxx] , T4.105 with cab, with hi-lo transmission [ZxJT0xxxx] , T4.105 with cab, with mechanical or power shuttle transmission [ZxJT5xxxx] , T4.115 less cab, with hi-lo transmission [ZxJT0xxxx] , T4.115 less cab, with mechanical or power shuttle transmission [ZxJT5xxxx] , T4.115 with cab, with hi-lo transmission [ZxJT0xxxx] , T4.115 with cab, with mechanical or power shuttle transmission [ZxJT5xxxx] , T4.85 less cab, with hi-lo transmission [ZxJT0xxxx] , T4.85 less cab, with mechanical or power shuttle transmission [ZxJT5xxxx] , T4.85 with cab, with hi-lo transmission [ZxJT0xxxx] , T4.85 with cab, with mechanical or power shuttle transmission [ZxJT5xxxx] , T4.95 less cab, with hi-lo transmission [ZxJT0xxxx] , T4.95 less cab, with mechanical or power shuttle transmission [ZxJT5xxxx] , T4.95 with cab, with hi-lo transmission [ZxJT0xxxx] , T4.95 with cab, with mechanical or power shuttle transmission [ZxJT5xxxx]

Engine - Remove

1. Remove the engine hood (1), as indicated in **Hood - Remove (90.100)**.
2. Remove the battery, as described in **Battery - Remove (55.302)**.
3. Remove the tank, as described in **Fuel tank - Remove (10.216)**.
4. Loosen the retaining bolts (1). Remove the front wheel fenders (2) (if any). Do this on both sides.

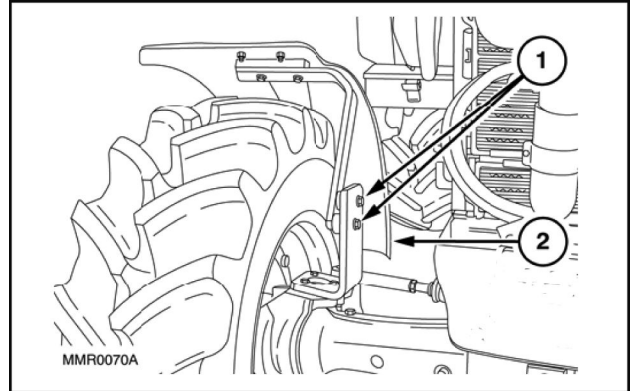

WLAPL4S10C104A 1

5. Recover the refrigerant from the system via the fittings (1) and (2) using the specific tool **380000315**. Detach the two lines by disconnecting any support straps.

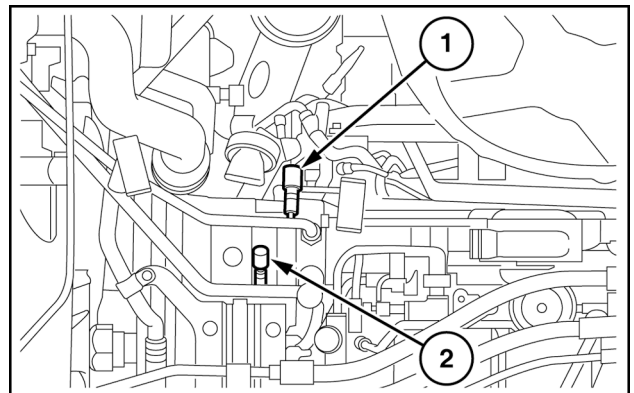

WLAPL4S10C106AA 2

6. Then detach the lower pipe (3) on the condenser (1). Free the pipe from any straps or clamps. Disconnect the sensor (2). Place the pipe on the cab.

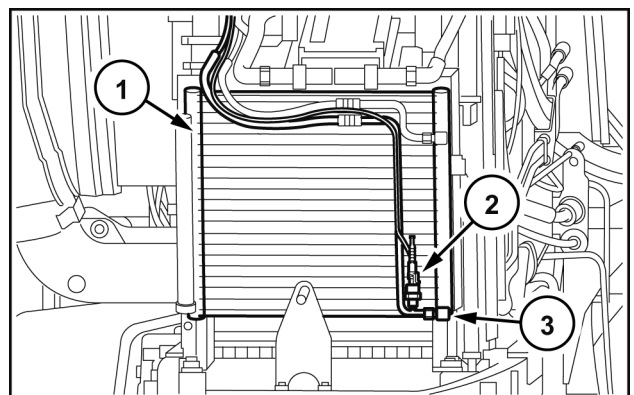

WLAPL4S10C107A 3

7. Raise the rear of the tractor with a hydraulic jack. Place a mechanical jack stand under the reduction gear case. Use a pneumatic gun to remove the retaining nuts of the left-hand rear wheel. Then remove the wheel.

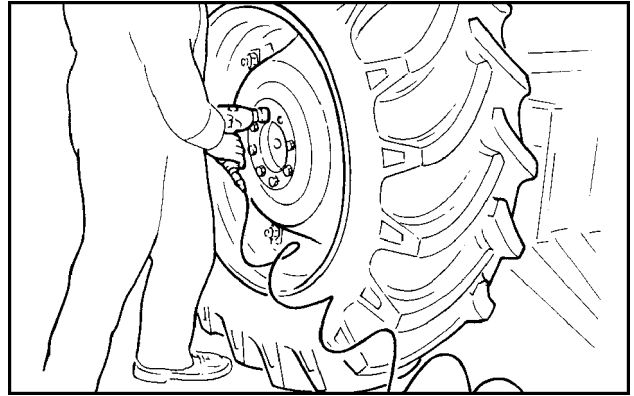

WLAPL4S10C110A 4

8. Unscrew the front, central, and rear retaining bolts on the guard of the front axle control shaft. Then remove the guard (1).

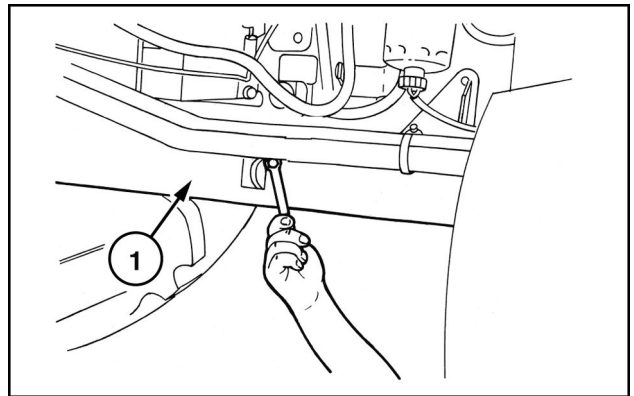

WLAPL4S10C112AA 5

9. Remove the circlip (2) and move the front sleeve (1) in the direction indicated by the arrow until it is released from the groove on the front axle.

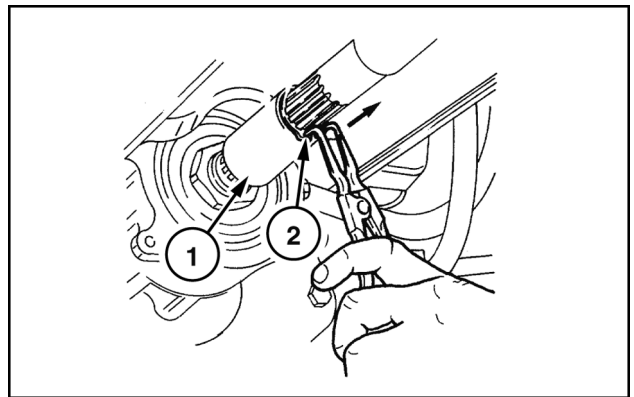

WLAPL4S10C113AA 6

10. Remove the bolts that secure the central support (1) of the drive shaft. Remove the shaft complete with the support. Also remove the shim that adjusts the clearance of the shaft on the back.

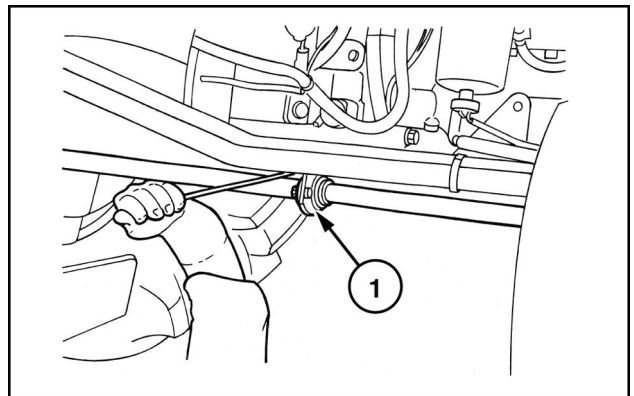

WLAPL4S10C115AA 7

11. Loosen the union of the radiator coolant return line of the cab heater. Drain and collect the engine coolant.

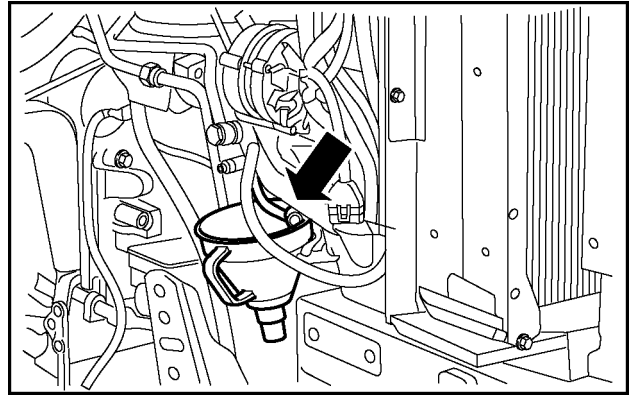

WLAPL4S10C116A 8

12. Place a suitable container under the drain plug (1) for the gearbox-transmission oil. Loosen the plug. Drain the oil.

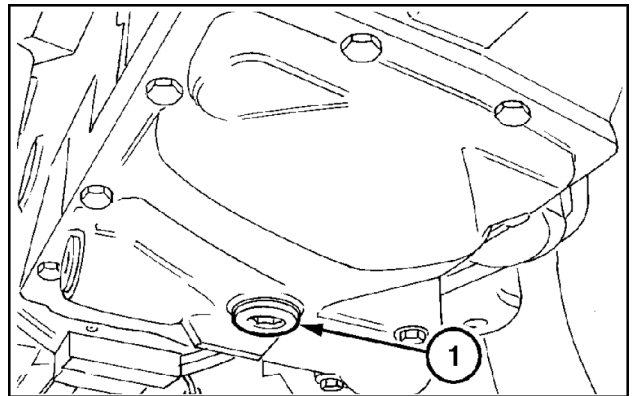

MOIL13TR00197AA 9

13. Remove the brakes reservoir heat shield (1).

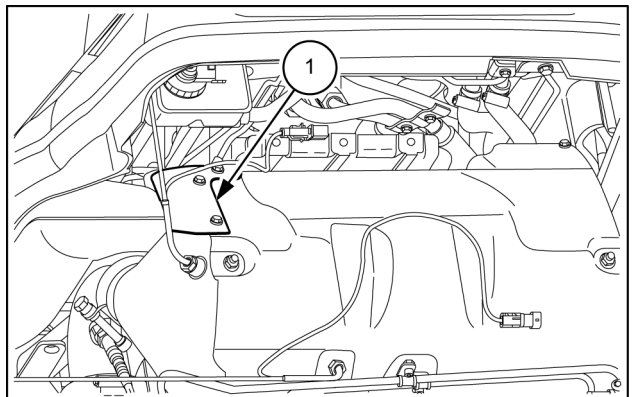

MOIL12APL98 10

14. Loosen the fixing clamp (1) to the filter DPF and the support clamp (2). Remove the exhaust pipe (3).

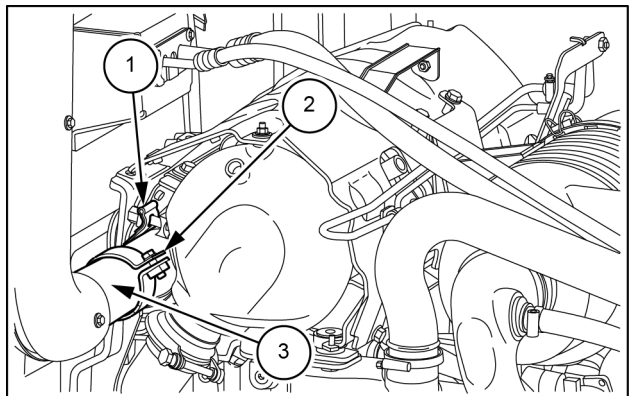

MOIL13TR01798AA 11

15. Loosen the fixing clamps (1). Extract the tubing from the turbine to the radiator intercooler (2). Perform the same operation for the tubing from the radiator intercooler to the engine (3).

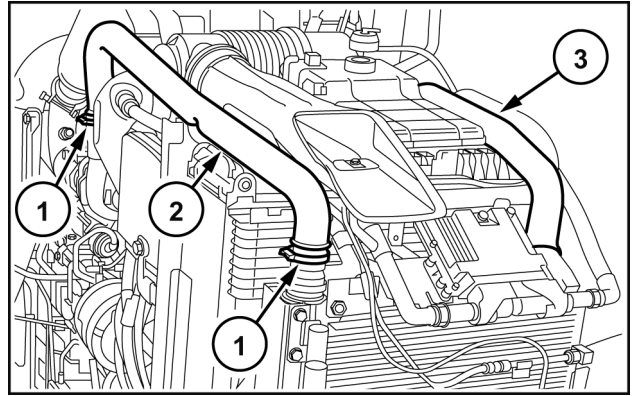

WLAPL4S10C119A 12

16. Loosen the clamp (2) that fastens the air intake duct to the turbine. Then free the air cleaner (4) together with the support bracket (3) from the screws that secure it. Disconnect the oil vapor duct (1) on the right-hand side of the engine.

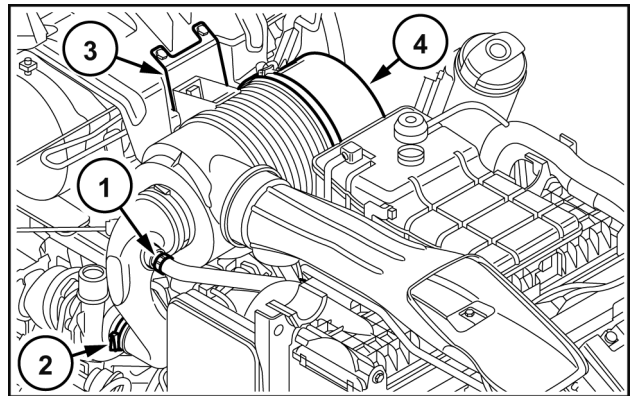

WLAPL4S10C120A 13

17. Free the air cleaner bracket – hood support (1) from the fixing screws and remove it.

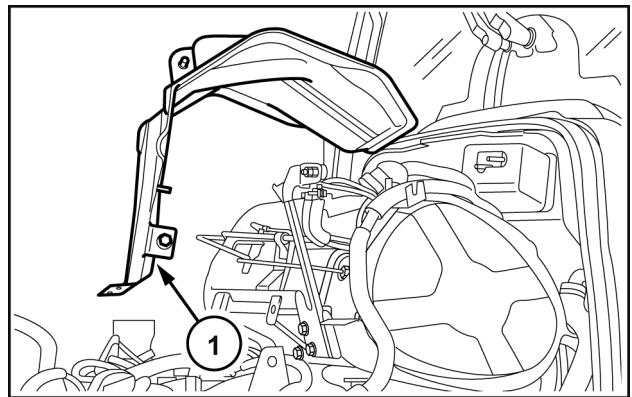

WLAPL4S10C121A 14

ATTENTION: The filter outlet union DPF (1) at its terminal (2) has a decoupler that responds to temperature variations by changing length.

A small misalignment of the axis of the decoupler with respect to the axis of the turbine outlet (3) would produce an adjustment that would no longer be lengthwise, in line with the direction of the tractor, but abnormal transversal adjustment that would impair its durability.



Suggest:

If the above button click is invalid.

Please download this document

first, and then click the above link

to download the complete manual.

Thank you so much for reading

18. Disconnect all of the filter sensors. Loosen the clamp (4). Remove the entire filter together with the sensors, pressure sensing tubes, lambda probe, and heat shrouds by undoing the four screws (5) that secure it on the bottom cradle.

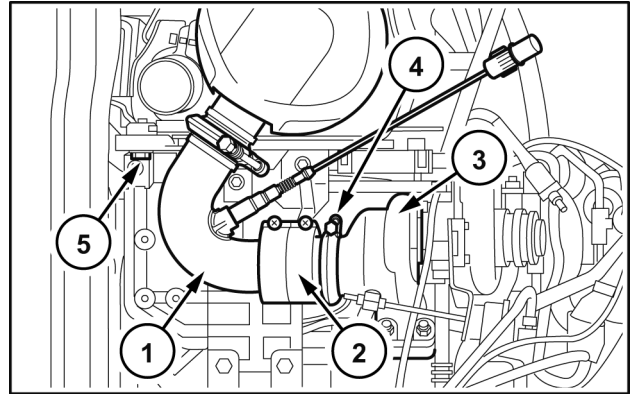

WLAPL4S10C122A 15

ATTENTION: Only if you have to work on the parts underneath the DPF filter support, it is advisable to remove the support.

The upper part (1) and the right-hand part (2) should be removed as a block, when possible, by removing the fixing screws (3) to the right-hand side of the engine. (These screws work on a vertical slot that allows the support (2) to take on various height positions). Before removal, take some references on the position of the unit on the engine so that, during re-assembly, it is possible to restore it to the exact position in which it was originally found.

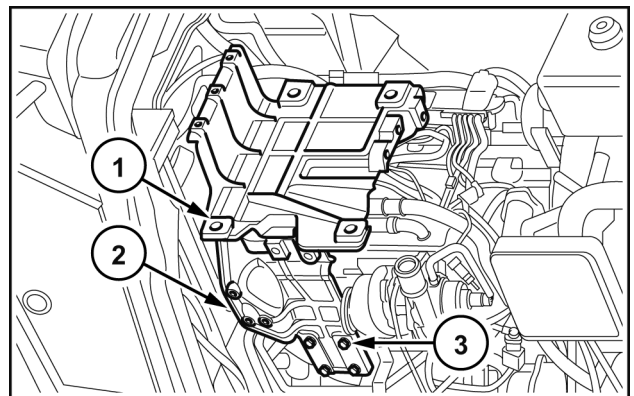

WLAPL4S10C123A 16

19. To remove the rear shield, loosen the two upper screws that fasten the support (4) to the support (1). To remove the left-hand support (5), loosen the two upper screws, the respective centring bushings that secure the left-hand bracket to the support (1). As regards removing the support (1) and (2), there are no special instructions to follow.

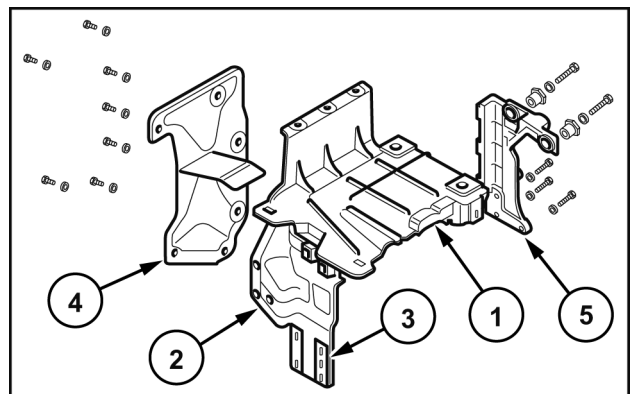

WLAPL4S10C124A 17

<https://www.ebooklibonline.com>

Hello dear friend!

Thank you very much for reading.

Enter the link into your browser.

The full manual is available for immediate download.

<https://www.ebooklibonline.com>