

SERVICE MANUAL

T9.435 / T9.480 / T9.530 / T9.565
T9.600 / T9.645 / T9.700

Tractor

PIN ZFF403001 and above

Part number 47924553

1st edition English

October 2015





SERVICE MANUAL

T9.435 Heavy duty wheeled model [ZFF403001 -] , T9.480 Heavy duty wheeled model [ZFF403001 -] , T9.530 Heavy duty wheeled model [ZFF403001 -] , T9.530 Wheeled scraper model [ZFF403001 -] , T9.565 Heavy duty wheeled model [ZFF403001 -] , T9.600 Heavy duty wheeled model [ZFF403001 -] , T9.600 Wheeled scraper model [ZFF403001 -] , T9.645 Heavy duty wheeled [ZFF403001 -] , T9.645 Standard wheeled model [ZFF403001 -] , T9.645 Wheeled scraper model [ZFF403001 -] , T9.700 Heavy duty wheeled model [ZFF403001 -]

Link Product / Engine

Product	Market Product	Engine
T9.435 Heavy duty wheeled model [ZFF403001 -]	Europe	F2CFE614A*B
T9.480 Heavy duty wheeled model [ZFF403001 -]	Europe	F3HFE613G*B001
T9.530 Heavy duty wheeled model [ZFF403001 -]	Europe	F3HFE613B*B001
T9.530 Wheeled scraper model [ZFF403001 -]	Europe	F3HFE613B*B001
T9.565 Heavy duty wheeled model [ZFF403001 -]	Europe	F3HFE613B*B001
T9.600 Heavy duty wheeled model [ZFF403001 -]	Europe	F3DFE613J*B001
T9.600 Wheeled scraper model [ZFF403001 -]	Europe	F3DFE613J*B001
T9.645 Standard wheeled model [ZFF403001 -]	Europe	F3DFE613G*B001
T9.645 Heavy duty wheeled [ZFF403001 -]	Europe	F3DFE613G*B001
T9.645 Wheeled scraper model [ZFF403001 -]	Europe	F3DFE613G*B001
T9.700 Heavy duty wheeled model [ZFF403001 -]	Europe	F3DFE613F*B001

<https://www.ebooklibonline.com>

Hello dear friend!

Thank you very much for reading.

Enter the link into your browser.

The full manual is available for immediate download.

<https://www.ebooklibonline.com>

Contents

INTRODUCTION

Engine	10
[10.001] Engine and crankcase	10.1
[10.216] Fuel tanks	10.2
[10.202] Air cleaners and lines	10.3
[10.310] Aftercooler.....	10.4
[10.400] Engine cooling system	10.5
[10.414] Fan and drive	10.6
[10.500] Selective Catalytic Reduction (SCR) exhaust treatment.....	10.7
Power coupling	19
[19.110] Flywheel damper	19.1
Transmission	21
[21.113] Powershift transmission	21.1
[21.135] Powershift transmission external controls.....	21.2
[21.155] Powershift transmission internal components.....	21.3
Front axle system	25
[25.100] Powered front axle	25.1
[25.102] Front bevel gear set and differential	25.2
[25.310] Final drives	25.3
Rear axle system	27
[27.100] Powered rear axle.....	27.1
[27.106] Rear bevel gear set and differential	27.2
[27.120] Planetary and final drives	27.3
Power Take-Off (PTO)	31
[31.104] Rear electro-hydraulic control.....	31.1
[31.110] One-speed rear Power Take-Off (PTO)	31.2

[31.220] Gearbox	31.3
Brakes and controls	33
[33.110] Parking brake or parking lock	33.1
[33.202] Hydraulic service brakes	33.2
Hydraulic systems.....	35
[35.000] Hydraulic systems.....	35.1
[35.102] Pump control valves.....	35.2
[35.105] Charge pump.....	35.3
[35.106] Variable displacement pump	35.4
[35.204] Remote control valves	35.5
[35.220] Auxiliary hydraulic pump and lines	35.6
[35.300] Reservoir, cooler, and filters.....	35.7
[35.304] Combination pump units	35.8
[35.600] High flow hydraulics	35.9
Hitches, drawbars, and implement couplings.....	37
[37.100] Drawbars and towing hitches	37.1
Frames and ballasting	39
[39.100] Frame	39.1
[39.110] Drawbar and hitch assembly	39.2
Steering.....	41
[41.101] Steering control	41.1
[41.200] Hydraulic control components.....	41.2
[41.206] Pump	41.3
Cab climate control	50
[50.104] Ventilation	50.1
[50.200] Air conditioning	50.2
[50.300] Cab pressurizing system	50.3

Electrical systems	55
[55.000] Electrical system	55.1
[55.100] Harnesses and connectors.....	55.2
[55.301] Alternator.....	55.3
[55.302] Battery.....	55.4
[55.010] Fuel injection system.....	55.5
[55.014] Engine intake and exhaust system.....	55.6
[55.024] Transmission control system	55.7
[55.045] Front axle control system	55.8
[55.046] Rear axle control system.....	55.9
[55.048] Rear Power Take-Off (PTO) control system	55.10
[55.050] Heating, Ventilation, and Air-Conditioning (HVAC) control system.....	55.11
[55.051] Cab Heating, Ventilation, and Air-Conditioning (HVAC) controls.....	55.12
[55.404] External lighting	55.13
[55.522] Cab Power Take-Off (PTO) controls	55.14
[55.640] Electronic modules	55.15
[55.035] Remote control valve electric control	55.16
[55.130] Rear three-point hitch electronic control system	55.17
[55.988] Selective Catalytic Reduction (SCR) electrical system	55.18
[55.DTC] FAULT CODES.....	55.19
Platform, cab, bodywork, and decals	90
[90.100] Engine hood and panels	90.1
[90.102] Engine shields, hood latches, and trims	90.2
[90.124] Pneumatically-adjusted operator seat.....	90.3
[90.150] Cab.....	90.4
[90.151] Cab interior.....	90.5



INTRODUCTION

Contents

INTRODUCTION

Foreword - Important notice regarding equipment servicing (*)	3
Safety rules (*)	4
Safety rules - Ecology and the environment (*)	5
Torque - Minimum tightening torques for normal assembly (*)	6
Torque - Standard torque data for hydraulics (*)	9
Basic instructions - Shop and assembly (*)	11
Hydraulic contamination (*)	13
Capacities (*)	14

(*) See content for specific models

Foreword - Important notice regarding equipment servicing

T9.	
-----	--

All repair and maintenance work listed in this manual must be carried out only by qualified dealership personnel, strictly complying with the instructions given, and using, whenever possible, the special tools.

Anyone who performs repair and maintenance operations without complying with the procedures provided herein shall be responsible for any subsequent damages.

The manufacturer and all the organizations of its distribution chain, including - without limitation - national, regional, or local dealers, reject any responsibility for damages caused by parts and/or components not approved by the manufacturer, including those used for the servicing or repair of the product manufactured or marketed by the manufacturer. In any case, no warranty is given or attributed on the product manufactured or marketed by the manufacturer in case of damages caused by parts and/or components not approved by the manufacturer.

The manufacturer reserves the right to make improvements in design and changes in specifications at any time without notice and without incurring any obligation to install them on units previously sold. Specifications, descriptions, and illustrative material herein are as accurate as known at time of publication but are subject to change without notice.

In case of questions, refer to your NEW HOLLAND Sales and Service Networks.

Safety rules

T9.

Personal safety





This is the safety alert symbol. It is used to alert you to potential personal injury hazards. Obey all safety messages that follow this symbol to avoid possible death or injury.

Throughout this manual you will find the signal words DANGER, WARNING, and CAUTION followed by special instructions. These precautions are intended for the personal safety of you and those working with you.

Read and understand all the safety messages in this manual before you operate or service the machine.

 DANGER indicates a hazardous situation that, if not avoided, will result in death or serious injury.

 WARNING indicates a hazardous situation that, if not avoided, could result in death or serious injury.

 CAUTION indicates a hazardous situation that, if not avoided, could result in minor or moderate injury.

FAILURE TO FOLLOW DANGER, WARNING, AND CAUTION MESSAGES COULD RESULT IN DEATH OR SERIOUS INJURY.

Machine safety

NOTICE: Notice indicates a situation that, if not avoided, could result in machine or property damage.

Throughout this manual you will find the signal word Notice followed by special instructions to prevent machine or property damage. The word Notice is used to address practices not related to personal safety.

Information

NOTE: Note indicates additional information that clarifies steps, procedures, or other information in this manual.

Throughout this manual you will find the word Note followed by additional information about a step, procedure, or other information in the manual. The word Note is not intended to address personal safety or property damage.

Safety rules - Ecology and the environment

T9.

Soil, air, and water quality is important for all industries and life in general. When legislation does not yet rule the treatment of some of the substances that advanced technology requires, sound judgment should govern the use and disposal of products of a chemical and petrochemical nature.

Familiarize yourself with the relative legislation applicable to your country, and make sure that you understand this legislation. Where no legislation exists, obtain information from suppliers of oils, filters, batteries, fuels, anti-freeze, cleaning agents, etc., with regard to the effect of these substances on man and nature and how to safely store, use, and dispose of these substances.

Helpful hints

- Avoid the use of cans or other inappropriate pressurized fuel delivery systems to fill tanks. Such delivery systems may cause considerable spillage.
- In general, avoid skin contact with all fuels, oils, acids, solvents, etc. Most of these products contain substances that may be harmful to your health.
- Modern oils contain additives. Do not burn contaminated fuels and or waste oils in ordinary heating systems.
- Avoid spillage when you drain fluids such as used engine coolant mixtures, engine oil, hydraulic fluid, brake fluid, etc. Do not mix drained brake fluids or fuels with lubricants. Store all drained fluids safely until you can dispose of the fluids in a proper way that complies with all local legislation and available resources.
- Do not allow coolant mixtures to get into the soil. Collect and dispose of coolant mixtures properly.
- The air-conditioning system contains gases that should not be released into the atmosphere. Consult an air-conditioning specialist or use a special extractor to recharge the system properly.
- Repair any leaks or defects in the engine cooling system or hydraulic system immediately.
- Do not increase the pressure in a pressurized circuit as this may lead to a component failure.
- Protect hoses during welding. Penetrating weld splatter may burn a hole or weaken hoses, allowing the loss of oils, coolant, etc.

Battery recycling

Batteries and electric accumulators contain several substances that can have a harmful effect on the environment if the batteries are not properly recycled after use. Improper disposal of batteries can contaminate the soil, groundwater, and waterways. NEW HOLLAND strongly recommends that you return all used batteries to a NEW HOLLAND dealer, who will dispose of the used batteries or recycle the used batteries properly. In some countries, this is a legal requirement.



Mandatory battery recycling

NOTE: *The following requirements are mandatory in Brazil.*

Batteries are made of lead plates and a sulfuric acid solution. Because batteries contain heavy metals such as lead, CONAMA Resolution 401/2008 requires you to return all used batteries to the battery dealer when you replace any batteries. Do not dispose of batteries in your household garbage.

Points of sale are obliged to:

- Accept the return of your used batteries
- Store the returned batteries in a suitable location
- Send the returned batteries to the battery manufacturer for recycling



SERVICE MANUAL

Engine

T9.435 Heavy duty wheeled model [ZFF403001 -] , T9.480 Heavy duty wheeled model [ZFF403001 -] , T9.530 Heavy duty wheeled model [ZFF403001 -] , T9.530 Wheeled scraper model [ZFF403001 -] , T9.565 Heavy duty wheeled model [ZFF403001 -] , T9.600 Heavy duty wheeled model [ZFF403001 -] , T9.600 Wheeled scraper model [ZFF403001 -] , T9.645 Heavy duty wheeled [ZFF403001 -] , T9.645 Standard wheeled model [ZFF403001 -] , T9.645 Wheeled scraper model [ZFF403001 -] , T9.700 Heavy duty wheeled model [ZFF403001 -]

Contents

Engine - 10

[10.001] Engine and crankcase	10.1
[10.216] Fuel tanks	10.2
[10.202] Air cleaners and lines	10.3
[10.310] Aftercooler.....	10.4
[10.400] Engine cooling system	10.5
[10.414] Fan and drive	10.6
[10.500] Selective Catalytic Reduction (SCR) exhaust treatment.....	10.7



Engine - 10

Engine and crankcase - 001

T9.435 Heavy duty wheeled model [ZFF403001 -] , T9.480 Heavy duty wheeled model [ZFF403001 -] , T9.530 Heavy duty wheeled model [ZFF403001 -] , T9.530 Wheeled scraper model [ZFF403001 -] , T9.565 Heavy duty wheeled model [ZFF403001 -] , T9.600 Heavy duty wheeled model [ZFF403001 -] , T9.600 Wheeled scraper model [ZFF403001 -] , T9.645 Heavy duty wheeled [ZFF403001 -] , T9.645 Standard wheeled model [ZFF403001 -] , T9.645 Wheeled scraper model [ZFF403001 -] , T9.700 Heavy duty wheeled model [ZFF403001 -]

Contents

Engine - 10

Engine and crankcase - 001

SERVICE

Engine

Change fluid - Changing engine oil and filter (*)	3
Remove - 9L (*)	6
Install - 9L (*)	15
Remove - 13L single turbo (*)	24
Install - 13L single turbo (*)	34
Remove - 13L dual stage turbo (*)	44
Install - 13L dual stage turbo (*)	52
Service instruction - 13L single turbo valve cover access (*)	60
Service instruction - 13L dual stage turbo, valve cover access (*)	63

(*) See content for specific models

Engine - Change fluid - Changing engine oil and filter

T9.

NOTE: Reduce to 300 hours or less if **NEW HOLLAND AMBRA UNITEK MASTERGOLD SBL CJ-4** is not used.

Change the engine oil and filter every 600 hours or once a year or before storage, whichever occurs first. Your dealer has approved oil and filters. Do not use other types of oil or filters.

NOTE: For best results change the oil and filter while the engine is still warm to the touch from operation (not hot). The tractor must be on a level surface.

Remove the engine side shields.

9L engine

1. Remove the oil pan drain plug and drain the oil from the engine into a container.
2. After all oil has drained, install new washer 98474302 on drain plug, center washer on plug and install drain plug. Torque drain plug to **30 N·m (22 lb ft)**.
3. Clean the area around the filter head and housing on the left side of the engine. Place a container under the oil filter and turn the filter housing counterclockwise to loosen with a **51 mm (2 in)** wrench. After all oil has drained from the filter, remove the housing with filter.

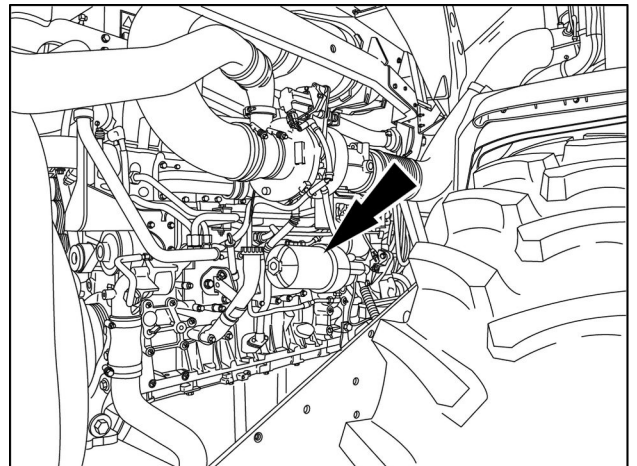

RAIL13TR04406AA 1

4. Install the new filter cartridge and O-ring. Lightly oil new O-ring.
4. Reinstall the filter assembly onto the tractor. Do not over tighten or O-ring will leak.

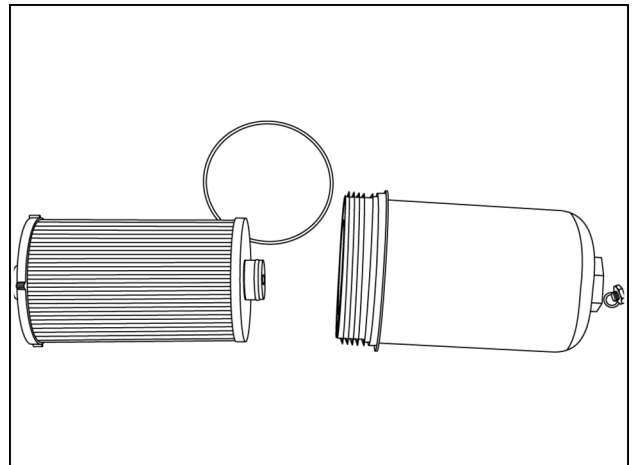

RCPH10FWD928BAM 2



Suggest:

If the above button click is invalid.

Please download this document

first, and then click the above link

to download the complete manual.

Thank you so much for reading

5. Fill with new oil into the engine oil fill **(1)**.

NOTE: Total oil refill capacity will be determined by how completely the crankcase drains. Do not fill above the high mark on the dipstick **(2)** when refilling.

6. Operate the engine for five minutes at **1000 RPM**. Check for oil leaks at the filter base and drain plug.
7. Stop the engine. Wait approximately five minutes for the oil to return to the oil pan. Check the oil level on the dipstick **(2)** and add oil if needed.

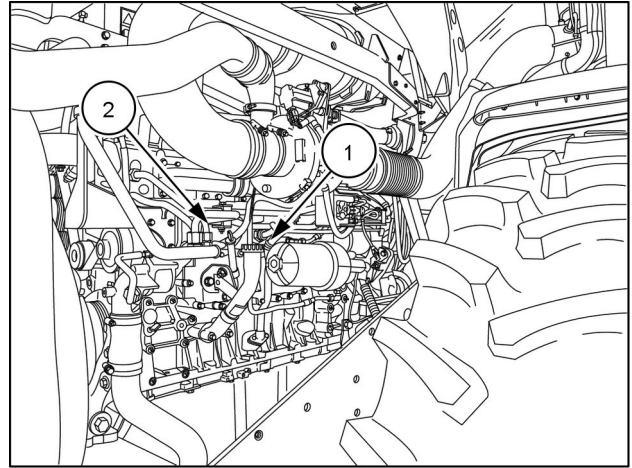

RAIL13TR0406AA 3

13L engines

1. Remove the oil pan drain plug and drain the oil from the engine into a container.
2. After all oil has drained, install new washer 98474302 on drain plug, center washer on plug and install drain plug. Torque drain plug to **30 N·m (22 lb ft)**.
3. Place a container under the oil filter on the left side of the engine. Use a **19 mm (0.75 in)** socket to open drain on bottom of housing. This will allow oil to drain from the housing. After oil is drained, turn the filter housing counterclockwise to loosen with a **51 mm (2 in)** wrench and remove the filter housing.

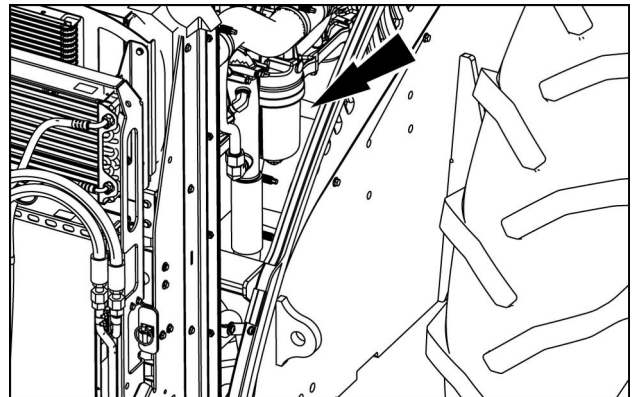

RAIL14TR00085AA 4

4. Install the new filter cartridge and O-ring.
4. Reinstall the filter assembly. Do not over tighten or the O-ring will leak.

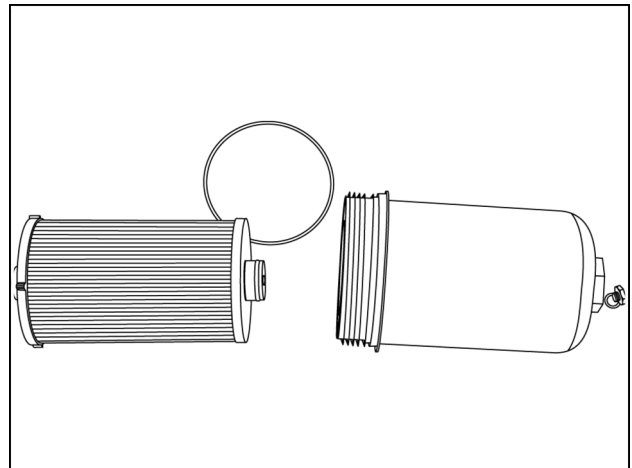

RCPH10FWD928BAM 5

<https://www.ebooklibonline.com>

Hello dear friend!

Thank you very much for reading.

Enter the link into your browser.

The full manual is available for immediate download.

<https://www.ebooklibonline.com>