

SERVICE MANUAL

T3.50F / T3.55F / T3.65F / T3.75F
Tractor

Part number 47977155
English
February 2016





SERVICE MANUAL

T3.50F

T3.55F

T3.65F

T3.75F

Contents

INTRODUCTION

Engine.....	10
[10.001] Engine and crankcase	10.1
[10.106] Valve drive and gears	10.2
[10.101] Cylinder heads	10.3
[10.105] Connecting rods and pistons.....	10.4
[10.103] Crankshaft and flywheel.....	10.5
[10.218] Fuel injection system	10.6
[10.400] Engine cooling system	10.7
[10.414] Fan and drive	10.8
[10.304] Engine lubrication system.....	10.9
Clutch	18
[18.110] Clutch and components	18.1
Transmission.....	21
[21.114] Mechanical transmission	21.1
[21.112] Power shuttle transmission.....	21.2
[21.160] Creeper	21.3
[21.120] Gearbox	21.4
Four-Wheel Drive (4WD) system	23
[23.101] Mechanical control	23.1
[23.202] Electro-hydraulic control	23.2
[23.314] Drive shaft.....	23.3
Front axle system	25
[25.100] Powered front axle	25.1
[25.102] Front bevel gear set and differential	25.2
[25.108] Final drive hub, steering knuckles, and shafts	25.3

<https://www.ebooklibonline.com>

Hello dear friend!

Thank you very much for reading.

Enter the link into your browser.

The full manual is available for immediate download.

<https://www.ebooklibonline.com>

Rear axle system	27
[27.100] Powered rear axle.....	27.1
[27.106] Rear bevel gear set and differential.....	27.2
[27.120] Planetary and final drives.....	27.3
Hydrostatic drive	29
[29.300] Rear hydrostatic transmission.....	29.1
Power Take-Off (PTO)	31
[31.101] Rear mechanical control.....	31.1
[31.225] Clutches.....	31.2
Brakes and controls	33
[33.202] Hydraulic service brakes.....	33.1
[33.110] Parking brake or parking lock.....	33.2
[33.220] Trailer brake hydraulic control.....	33.3
Hydraulic systems	35
[35.525] Auxiliary hydraulic valves and lines.....	35.1
[35.162] Front hitch cylinders and lines.....	35.2
[35.100] Main lift system.....	35.3
Steering	41
[41.101] Steering control.....	41.1
[41.216] Cylinders.....	41.2
Wheels	44
[44.511] Front wheels.....	44.1
Electrical systems	55
[55.000] Electrical system.....	55.1
[55.100] Harnesses and connectors.....	55.2
[55.201] Engine starting system.....	55.3
[55.301] Alternator.....	55.4
[55.302] Battery.....	55.5

[55.013] Engine oil system	55.6
[55.024] Transmission control system	55.7
[55.512] Cab controls.....	55.8
Platform, cab, bodywork, and decals	90
[90.110] Operator platform less cab	90.1



INTRODUCTION

Safety rules

T3.F

WE

Pay attention to this symbol

This warning symbol points out important messages concerning your safety.

Carefully read the following safety regulations and observe advised precautions in order to avoid potential hazards and safeguard your health and safety.

In this manual the symbol is accompanied by the following key-words:

WARNING: Warnings concerning unsuitable repair operations that may jeopardise the safety of Repair personnel.

DANGER: Specific warnings concerning potential hazards for operator safety or for other persons directly or indirectly involved.

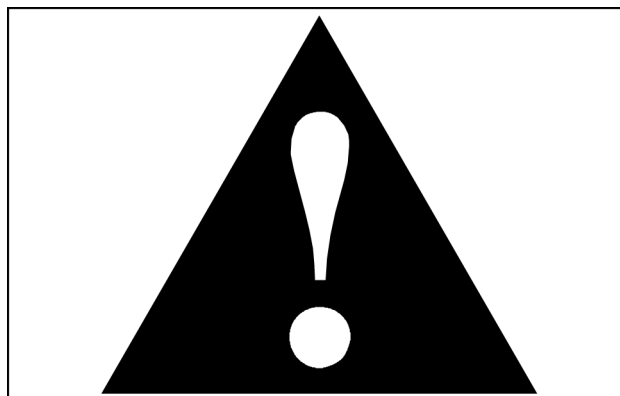

ANIL15TR0707AA 1

To prevent accidents

Most accidents or injuries that occur in workshops are the result of non-observance of simple and fundamental safety regulations. For this reason, **IN MOST CASES THESE ACCIDENTS CAN BE AVOIDED** by foreseeing possible causes and consequently acting with the necessary caution and care.

Accidents may occur with all types of vehicle, regardless of how well it was designed and built.

A careful and judicious service technician is the best guarantee against accidents.

Precise observance of the most basic safety rule is normally sufficient to avoid many serious accidents.

DANGER: Never carry out any cleaning, lubrication or maintenance operations when the engine is running.

Safety rules

General guidelines:

- Carefully follow specified repair and maintenance procedures.
- Do not wear rings, wristwatches, jewels, unbuttoned or flapping clothing such as ties, torn clothes, scarves, open jackets or shirts with open zips which could get caught on moving parts.
Use approved safety clothing such as anti-slipping footwear, gloves, safety goggles, helmets, etc.
- Do not carry out repair operations with someone sitting in the driver's seat, unless the person is a trained technician who is assisting with the operation in question.
- Do not operate the vehicle or use any of the implements from different positions, other than the driver's seat.
- Do not carry out operations on the vehicle with the engine running, unless specifically indicated.
- Stop the engine and ensure that all pressure is relieved from hydraulic circuits before removing caps, covers, valves, etc.
- All repair and maintenance operations must be carried out using extreme care and attention.
- Service steps and platforms used in a workshop or in the field should be built in compliance with the safety rules in force.
- Disconnect the batteries and label all controls to indicate that the vehicle is being serviced. Block the machine and all equipment which should be raised.
- Do not check or fill fuel tanks, accumulator batteries, nor use starting liquid when smoking or near naked flames, as these fluids are inflammable.

INTRODUCTION

- Brakes are inoperative when manually released for repair or maintenance purposes. Use blocks or similar devices to control the machine in these conditions.
- The fuel nozzle should always be in contact with the filling aperture: Maintain this contact until the fuel stops flowing into the tank to avoid possible sparks due to static electricity buildup.
- Only use specified towing points for towing the vehicle. Connect parts carefully. Make sure that all pins and/or locks are secured in position before applying traction. Never remain near the towing bars, cables or chains that are operating under load.
- Transport vehicles that cannot be driven using a trailer or a low-loading platform trolley, if available.
- When loading or unloading the vehicle from the trailer (or other means of transport), select a flat area capable of sustaining the trailer or truck wheels. Firmly secure the vehicle to the truck or trailer and lock the wheels in the position used by the carrier.
- Electric heaters, battery-chargers and similar equipment must only be powered by auxiliary power supplies with efficient ground insulation to avoid electrical shock hazards.
- Always use suitable hoisting or lifting devices when raising or moving heavy parts.
- Take extra care if bystanders are present.
- Never pour petrol or diesel oil into open, wide or low containers.
- Never use gasoline, diesel oil or other inflammable liquids as cleaning agents. Use non-inflammable, non-toxic commercially available solvents.
- Wear safety goggles with side guards when cleaning parts with compressed air.
- Limit the air pressure to a maximum of **2.1 bar**, according to local regulations.
- Do not run the engine in confined spaces without suitable ventilation.
- Do not smoke, use naked flames, or cause sparks in the area when fuel filling or handling highly inflammable liquids.
- All movements must be carried out carefully when working under, on or near the vehicle. Wear suitable safety clothing, i.e., hard hat, safety goggles and special shoes.
- When carrying out checks with the engine running, request the assistance of an operator in the driver's seat. The operator must maintain visual contact with the service technician at all times.
- If operating outside the workshop, position the vehicle on a flat surface and lock in position. If working on a slope, lock the vehicle in position. Move to a flat area as soon as is safely possible.
- If operating outside the workshop, position the vehicle on a flat surface and lock in position. If working on a slope, lock the vehicle in position. Move to a flat area as soon as is safely possible.
- Damaged or bent chains or cables are unreliable. Do not use them for lifting or towing. Always use suitable protective gloves when handling chains or cables.
- Chains should always be safely secured. Make sure that the hitch-up point is capable of sustaining the load in question. Keep the area near the hitch-up point, chains or cables free of all bystanders.
- Maintenance and repair operations must be carried out in a CLEAN and DRY area. Eliminate any water or oil spillage immediately.
- Do not create piles of oil or grease-soaked rags as they represent a serious fire hazard. Always place them into a metal container.
Before starting the tractor or its attachments, check, adjust and block the operator's seat. Also check that there are no persons within the vehicle or implement range of action.
- Empty pockets of all objects that may fall unobserved into the vehicle parts.
- In the presence of protruding metal parts, use protective goggles or goggles with side guards, helmets, special footwear and gloves.
- When welding, use protective safety devices: tinted safety goggles, helmets, special overalls, gloves and footwear. All persons present in the area where welding is taking place must wear tinted goggles. **NEVER LOOK DIRECTLY AT THE WELDING ARC WITHOUT SUITABLE EYE PROTECTION.**
- Metal cables tend to fray with repeated use. Always use suitable protective devices (gloves, goggles, etc.) when handling cables.
- Handle all parts with great care. Do not put your hands or fingers between moving parts. Always wear suitable safety clothing-safety goggles, gloves and shoes.

Starting

- Never run the engine in confined spaces that are not equipped with adequate ventilation for exhaust gas extraction.
- Never place the head, body, limbs, feet, hands or fingers near fans or rotating belts.

Engine

- Always loosen the radiator cap slowly before removing it to allow any remaining pressure in the system to be discharged. Filling up with coolant should only be carried out with the engine stopped or idling (if hot).
- Never fill up with fuel when the engine is running, especially if hot, in order to prevent the outbreak of fire as a result of fuel spillage.
- Never check or adjust fan belt tension when the engine is running.
Never adjust the fuel injection pump when the vehicle is moving.
- Never lubricate the vehicle when the engine is running.

Electrical systems

- If it is necessary to use auxiliary batteries, remember that both ends of the cables must be connected as follows: (+) with (+) and (-) with (-).
Avoid short-circuiting the terminals. **GAS RELEASED FROM BATTERIES IS HIGHLY INFLAMMABLE.** During charging, leave the battery compartment uncovered to improve ventilation. Never check the battery charge using “jumpers” (metal objects placed on the terminals). Avoid sparks or flames near the battery zone. Do not smoke to prevent explosion hazards.
- Before servicing operations, check for fuel or current leaks. Eliminate any eventual leaks before proceeding with work.
- Never charge batteries in confined spaces. Make sure that there is adequate ventilation in order to prevent accidental explosion hazards as a result of the accumulation of gases released during charging operations.
- Always disconnect the batteries before performing any kind of servicing on the electrical system.

Hydraulic systems

- A liquid leaking from a tiny hole may be almost invisible but, at the same time, be powerful enough to penetrate the skin. Therefore, use a piece of cardboard or wood for this purpose. **NEVER DO IT WITH YOUR HANDS:** If any liquid penetrates skin tissue, call for medical aid immediately. Failure to treat this condition with correct medical procedure may result in serious infection or dermatosis.
- In order to check the pressure in the system use suitable instruments.

Wheels and tyres

- Make sure that the tyres are correctly inflated at the pressure specified by the manufacturer. Periodically check possible damages to the rims and tyres.
- Stand away from (at the side of) the tyre when checking inflation pressure.
- Only check pressure when the vehicle is unloaded and the tyres are cold, to avoid incorrect readings as a result of over-pressure.
Do not reuse parts of recovered wheels as improper welding, brazing or heating may weaken the wheel and make it fail.
- Never cut or weld a rim mounted with an inflated tyre.
- To remove the wheels, lock both the front and rear vehicle wheels. After having raised the vehicle, position supports underneath, according to regulations in force.
- Deflate the tyre before removing any object caught in the tyre tread.
- Never inflate tyres using inflammable gases, as this may result in explosions and injury to by standards.



SERVICE MANUAL

Engine

T3.50F

T3.55F

T3.65F

T3.75F

CONSUMABLES INDEX

Consumable	Reference	PAGE
Loctite®	Engine - Install	10.1 / 27
Loctite®	Engine - Install	10.1 / 27
NEW HOLLAND AMBRA AGRIFLU	Engine cooling system - Overview	10.7 / 5
NEW HOLLAND AMBRA AGRIFLU	Engine cooling system - Overview	10.7 / 5

Engine - General specification

T3.F	WE
General specification	3 cylinder
Engine type :	–
T 3.50F model turbocharged – 8035.25A.313T- (BOSCHpompa)	BOSCH 1068-1 T
T 3.55F model turbocharged – 8035.25B.313T (BOSCHpompa)	BOSCH 1068-1
T 3.65F model turbocharged - 8035.25C.313T (BOSCHpompa)	BOSCH 1068-2
T 3.75F model turbocharged - 8035.25D.313T (BOSCHpompa)	BOSCH 1089
Type:	
Fuel injection	Diesel 4 stroke
Number of cylinders in line	Direct 3
Piston diameter	
T 3.50 F model	104 mm
T 3.55 F model	104 mm
T 3.65 F model	104 mm
T 3.75 F model	104 mm
Piston stroke	115 mm
Total displacement :	
T 3.50 F model	2930 cm³
T 3.55 F model	2930 cm³
T 3.65 F model	2930 cm³
T 3.75 F model	2930 cm³
Compression ratio	18:1
Maximum power	
T 3.50 F model	36.8 kW (50 Hp)
T 3.55 F model	40.4 kW (55 Hp)
T 3.65 F model	47.8 kW (65 Hp)
T 3.75 F model	53.0 kW (72 Hp)
Maximum torque	
Maximum torque (Nm) at 1400 d/dak: T 3.50 F model	201 N·m
Maximum torque (Nm) at 1400 d/dak: T 3.55 F model	220 N·m
Maximum torque (Nm) at 1400 d/dak: T 3.65 F model	261 N·m
Maximum torque (Nm) at 1400 d/dak: T 3.75 F model	295 N·m
Number of main bearings	4
Sump	Structural cast iron
Lubrication	Forced, with gear pump
Pump drive	From camshaft
Engine speed / oil pump speed ratio	2:1
Oil cleaning	Mesh filter on oil intake and cartridge filter on delivery line
Normal oil pressure, with engine hot and at fast idling speed:	2.9 - 3.9 bar (42.0 - 56.6 psi)
All models	
Lube pressure relief valve	Built into pump housing
Valve opening pressure	3.5 bar (50.8 psi)
For further lubrication data	See page 19
Cooling system	Coolant circulation
Radiator on T 3.50 F and T 3.55 F models	3 row vertical pipes with copper fins
Radiator on T 3.65 F and T 3.75 F models	4 row vertical pipes with copper fins
Fan, attached to coolant pump pulley T 3.50 F, T 3.55 F, T 3.65F, T 3.75 F models	10 blade steel exhauster fan
Coolant pump	Centrifugal vane-type

General specification	3 cylinder
Engine speed/coolant pump speed ratio	1.403/1
Temperature control	Thermostat
Coolant temperature gauge	Coloured scale, divided into 3 sections
Temperature ranges corresponding to each section:	
Initial white section	30 - 65 °C
Middle green section	65 - 105 °C
Final red section	105 - 115 °C
For further cooling system data	See page 20
Rev counter	Incorporated in instrument panel
Rev counter drive	From gear on camshaft
Timing	Overhead valves operated by a camshaft located in the engine block through tappets, pushrods and rockers. Camshaft is driven by the crankshaft through helical gears.
Intake:	
Start: Before T.D.C	12 °
End: After B.D.C	31 °
Exhaust:	
Start: Before B.D.C	50 °
End: After T.D.C	16 °
Valve clearance for timing check	0.45 mm
Valve clearance for normal running (engine cold):	
Intake	0.25 - 0.35 mm
Exhaust	0.25 - 0.35 mm
For further timing data	For valve timing check see Camshaft - Check (10.106) .
Fuel system	
Air filter	Dual cartridge dry air filter with clogged filter indicator, centrifugal pre-filter and automatic dust ejector
Fuel pump	Double diaphragm
Fuel Filter	Mesh filter in fuel supply pump and replaceable cartridge on delivery line to injection pump.
Minimum fuel flow rate with pump shaft rotating at 1600 RPM	100 L/hour
Operated by eccentric cam	On camshaft
BOSCH injection pump	Distributor type
All-speed governor, incorporated in pump: BOSCH	Centrifugal counterweights
For further fuel system data:	
For fixed advance (pump setting for start of delivery before TDC) – Pressure setting – Injection order, and other information regarding the BOSCH pump	See pages 10 to 99

Technical specifications

Turbocharger	
Holset	HX25
Fuel injection pump	Distributor type with incorporated speed governor and automatic advance regulator
BOSCH pump:	
T 3.50 F model	L 1135
T 3.55 F model	L 1134
T 3.65 F model	L 1136
T 3.75 F model	L 1137
Direction of rotation	Anti-clockwise
Injection order	1-2-3

Engine - Remove

T3.F

WE

⚠ DANGER: Lift and handle all heavy parts using suitable lifting equipment.
Make sure that assemblies or parts are supported by means of suitable slings and hooks.
Check that no one is in the vicinity of the load to be lifted.

⚠ WARNING: Always use suitable tools to align holes in parts.
NEVER USE FINGERS OR HANDS.

1. Disconnect the battery's negative cable (1).
2. Drain oil from the transmission/gearbox.

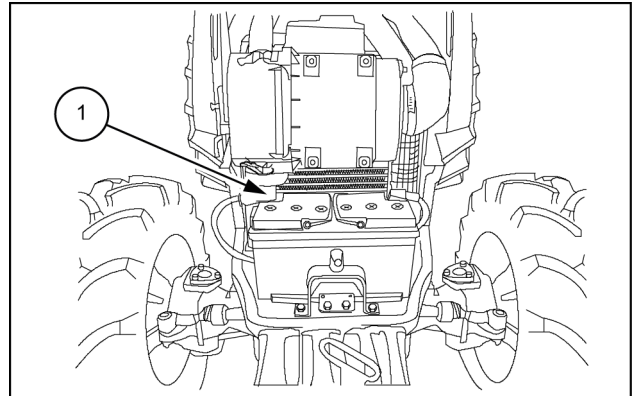

ANIL15TR00007AB 1

3. Unscrew the nut (1) from the weight retaining pin. Remove the weights (2) from the front support.

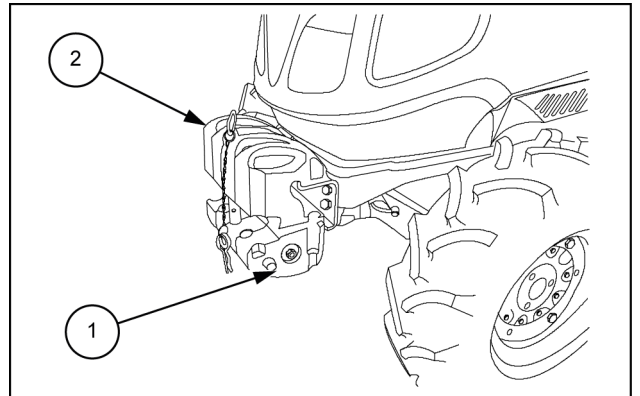

ANIL15TR00008AB 2

4. Detach the gas struts from the bonnet (1). Disconnect the electrical connection of bonnet (1).
5. Remove the guards (2) on the right and left hand side of the engine.

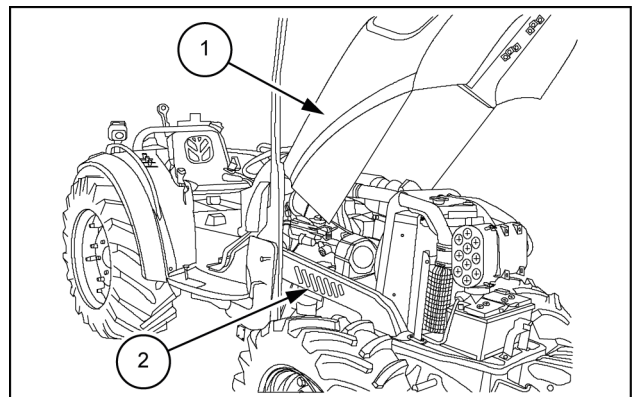

ANIL15TR00009AB 3

6. Detach the throttle and accelerator pedal control cable **(1)** from the pump.

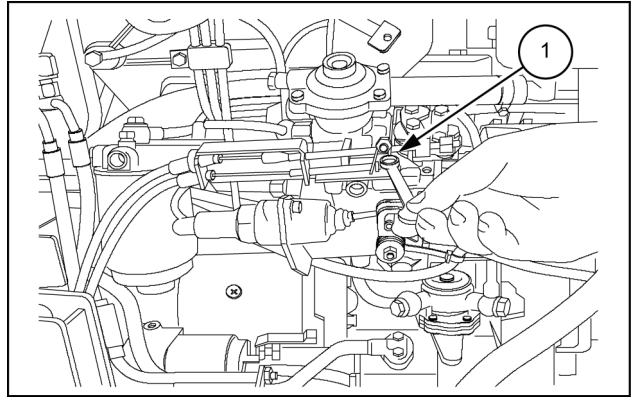

ANIL15TR00010AB 4

7. Remove fuel pipe bolt **(1)** on feeding pump.

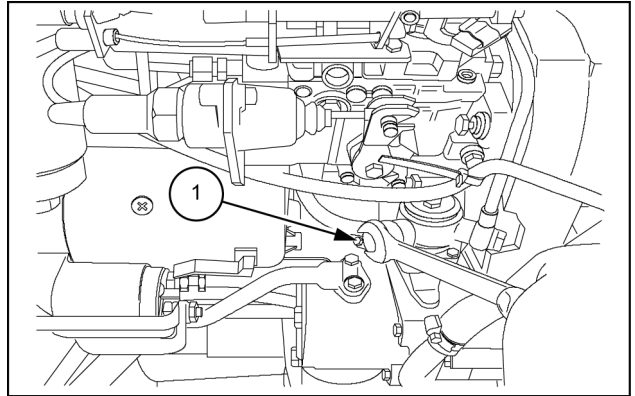

ANIL15TR00011AB 5

8. Disconnect the all electrical connectors.

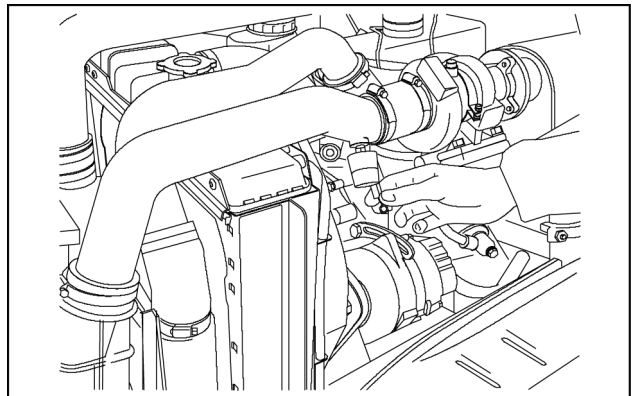

ANIL15TR00012AA 6

9. Disconnect the delivery and return lines **(1)** to the steering cylinders.

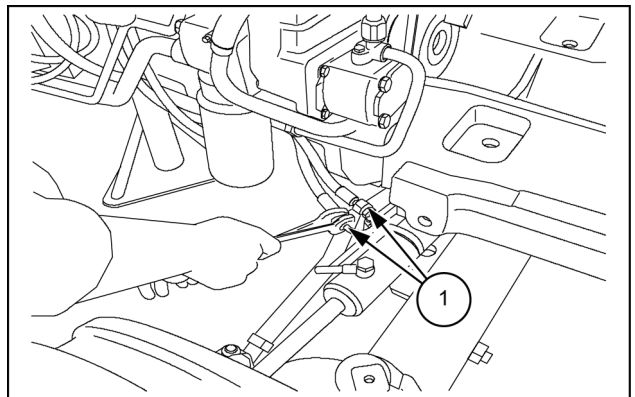

ANIL15TR00013AB 7

10. Remove the hose (1) from the lift pump suction pipe.

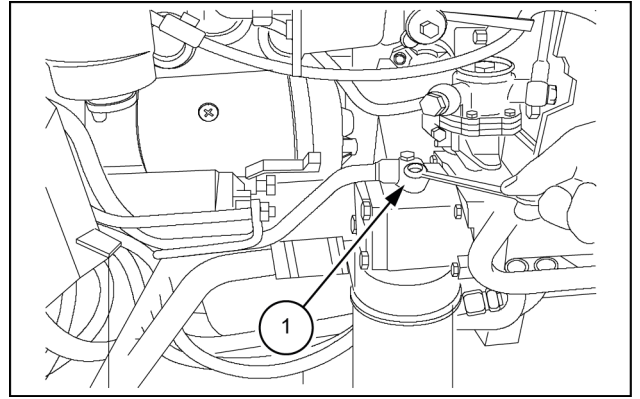

ANIL15TR00014AB 8

11. Disconnect the hydraulic steering hose (1) and pressure indicator (2).

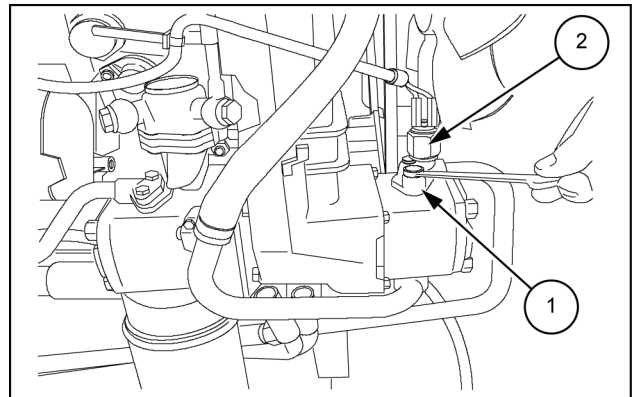

ANIL15TR00015AB 9

12. Remove the front, centre and rear retaining bolts from the front axle drive shaft guard and remove the guard.

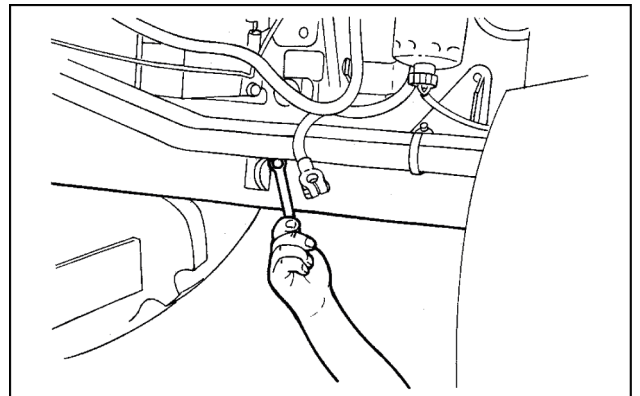

ANIL15TR00016A 10

13. Remove the circlip (2) from the front of the prop shaft and slide the sleeve (1), in the direction shown by the arrow, until it is free of the splines on the front axle.

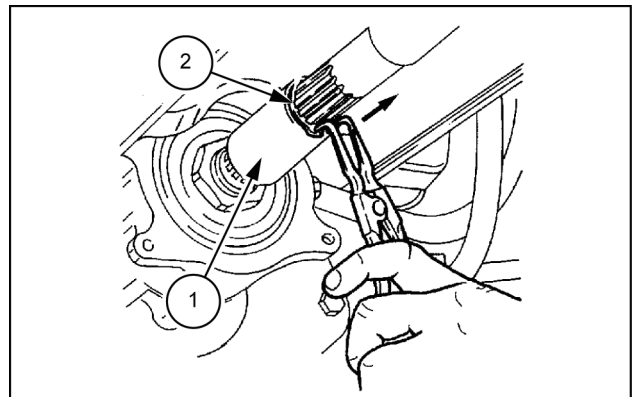

ANIL15TR00017AB 11



Suggest:

If the above button click is invalid.

Please download this document

first, and then click the above link

to download the complete manual.

Thank you so much for reading

14. Remove the circlip (2) from the rear of the prop shaft and slide the sleeve (1), in the direction shown by the arrow, until it is free of the splines on the crankshaft.

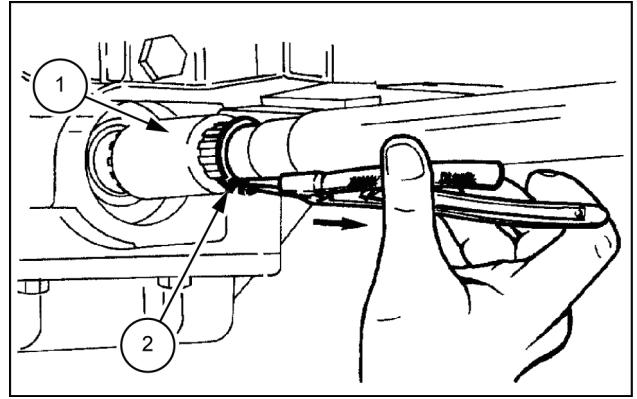

ANIL15TR00018AB 12

15. Remove the middle support bolts (1) from the propeller shaft and remove the shaft complete with support.

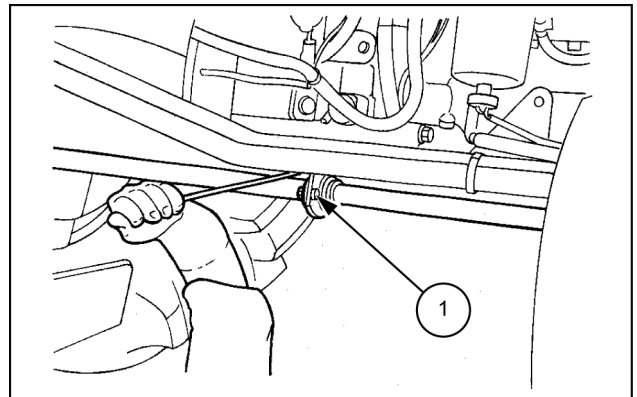

ANIL15TR00019AB 13

16. Remove the cover from the front panel (1).

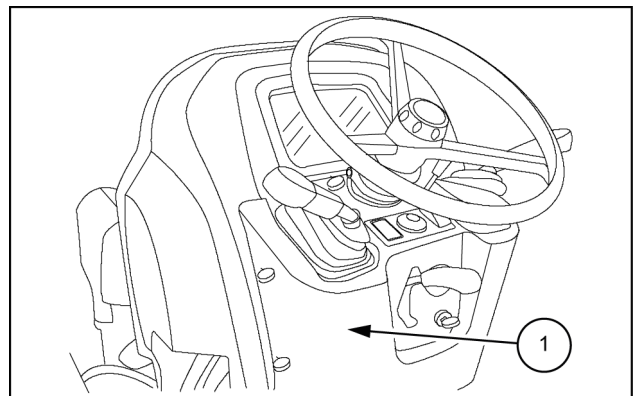

ANIL15TR00020AB 14

17. Remove the four transmission fixing bolts (1).

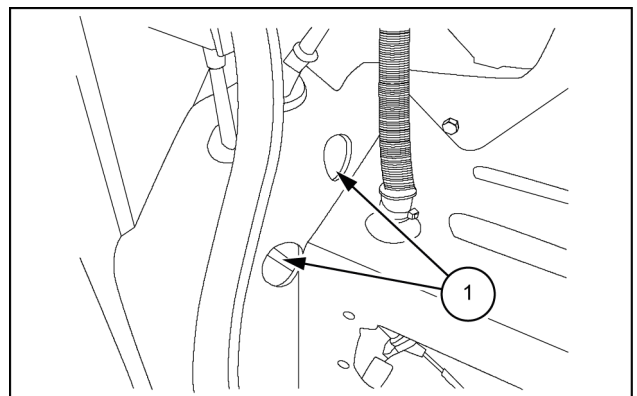

ANIL15TR00021AB 15

<https://www.ebooklibonline.com>

Hello dear friend!

Thank you very much for reading.

Enter the link into your browser.

The full manual is available for immediate download.

<https://www.ebooklibonline.com>