

SERVICE MANUAL

StackCruiser® 102

StackCruiser® 103

StackCruiser® 105

Tier 4B (final)

Bale Wagon

Part number 48190534

1st edition English
September 2017





SERVICE MANUAL

StackCruiser® 102

StackCruiser® 103

StackCruiser® 105

Link Product / Engine

Product	Market Product	Engine
StackCruiser® 102 Self-Propelled Bale Wagon, TIER 4B (FINAL), two-tie, three-wide [YHG651501 -]	North America	F4HFE6138*B004
StackCruiser® 103 Self-Propelled Bale Wagon, TIER 4B (FINAL), three-tie, two-wide [YHG651501 -]	North America	F4HFE6138*B004
StackCruiser® 105 Self-propelled Balewagon, TIER 4B (FINAL). Handles large, rectangular bales only. [YHG651501 -]	North America	F4HFE6138*B004

<https://www.ebooklibonline.com>

Hello dear friend!

Thank you very much for reading.

Enter the link into your browser.

The full manual is available for immediate download.

<https://www.ebooklibonline.com>

Contents

INTRODUCTION

Engine	10
[10.001] Engine and crankcase	10.1
[10.103] Crankshaft and flywheel.....	10.2
[10.202] Air cleaners and lines	10.3
[10.206] Fuel filters	10.4
[10.216] Fuel tanks	10.5
[10.304] Engine lubrication system.....	10.6
[10.310] Aftercooler.....	10.7
[10.400] Engine cooling system	10.8
[10.414] Fan and drive	10.9
[10.419] Stationary air screen	10.10
[10.500] Selective Catalytic Reduction (SCR) exhaust treatment.....	10.11
Power coupling	19
[19.100] Drive shaft.....	19.1
Transmission	21
[21.109] Transmission cooler and lines.....	21.1
[21.114] Mechanical transmission	21.2
[21.130] Mechanical transmission external controls.....	21.3
Front axle system	25
[25.400] Non-powered front axle	25.1
Rear axle system	27
[27.100] Powered rear axle.....	27.1
[27.106] Rear bevel gear set and differential	27.2
Brakes and controls	33
[33.110] Parking brake or parking lock	33.1

[33.120] Mechanical service brakes	33.2
[33.202] Hydraulic service brakes	33.3
Hydraulic systems.....	35
[35.000] Hydraulic systems.....	35.1
[35.102] Pump control valves.....	35.2
[35.104] Fixed displacement pump.....	35.3
[35.106] Variable displacement pump	35.4
[35.300] Reservoir, cooler, and filters.....	35.5
[35.359] Main control valve.....	35.6
[35.820] Hydraulic driven cooling fans	35.7
[35.913] Bale loading hydraulic system	35.8
[35.914] Bale storing and handling hydraulic system.....	35.9
[35.915] Bale unloading hydraulic system.....	35.10
Frames and ballasting	39
[39.100] Frame	39.1
[39.140] Ballasts and supports	39.2
Steering.....	41
[41.101] Steering control	41.1
[41.106] Tie rods.....	41.2
[41.200] Hydraulic control components.....	41.3
Wheels	44
[44.511] Front wheels.....	44.1
[44.520] Rear wheels.....	44.2
Cab climate control	50
[50.100] Heating.....	50.1
[50.104] Ventilation	50.2
[50.200] Air conditioning	50.3
Electrical systems.....	55

[55.000] Electrical system	55.1
[55.010] Fuel injection system.....	55.2
[55.012] Engine cooling system	55.3
[55.014] Engine intake and exhaust system.....	55.4
[55.015] Engine control system.....	55.5
[55.020] Transmission speed sensors.....	55.6
[55.024] Transmission control system.....	55.7
[55.030] Service brake electrical system	55.8
[55.031] Parking brake electrical system.....	55.9
[55.036] Hydraulic system control	55.10
[55.046] Rear axle control system.....	55.11
[55.047] Steering control system	55.12
[55.050] Heating, Ventilation, and Air-Conditioning (HVAC) control system.....	55.13
[55.051] Cab Heating, Ventilation, and Air-Conditioning (HVAC) controls.....	55.14
[55.069] Bale loading electrical system.....	55.15
[55.070] Bale storing and handling electrical system.....	55.16
[55.071] Bale unloading electrical system.....	55.17
[55.100] Harnesses and connectors.....	55.18
[55.201] Engine starting system	55.19
[55.301] Alternator.....	55.20
[55.302] Battery.....	55.21
[55.404] External lighting	55.22
[55.405] External lighting switches and relays	55.23
[55.408] Warning indicators, alarms, and instruments	55.24
[55.512] Cab controls.....	55.25
[55.514] Cab lighting	55.26
[55.518] Wiper and washer system.....	55.27
[55.519] Cab brake controls	55.28

[55.525] Cab engine controls	55.29
[55.640] Electronic modules	55.30
[55.785] Precision farming system	55.31
[55.988] Selective Catalytic Reduction (SCR) electrical system	55.32
[55.DTC] FAULT CODES	55.33
Bale wagons	69
[69.100] Bale loading	69.1
[69.200] Bale storing and handling	69.2
[69.300] Bale unloading	69.3
[69.400] Bale trip assembly	69.4
[69.500] Bale stabilizer and tine arch	69.5
[69.600] Bale return shaft assembly	69.6
Lubrication system	71
[71.460] Grease lubrication system	71.1
Platform, cab, bodywork, and decals	90
[90.105] Machine shields and guards	90.1
[90.116] Fenders and guards	90.2
[90.118] Protections and footboards	90.3
[90.124] Pneumatically-adjusted operator seat	90.4
[90.150] Cab	90.5
[90.151] Cab interior	90.6
[90.154] Cab doors and hatches	90.7
[90.160] Cab interior trim and panels	90.8



INTRODUCTION

Safety rules

Personal safety



This is the safety alert symbol. It is used to alert you to potential personal injury hazards. Obey all safety messages that follow this symbol to avoid possible death or injury.

Throughout this manual you will find the signal words **DANGER**, **WARNING**, and **CAUTION** followed by special instructions. These precautions are intended for the personal safety of you and those working with you.

Read and understand all the safety messages in this manual before you operate or service the machine.

 **DANGER** indicates a hazardous situation that, if not avoided, will result in death or serious injury.

 **WARNING** indicates a hazardous situation that, if not avoided, could result in death or serious injury.

 **CAUTION** indicates a hazardous situation that, if not avoided, could result in minor or moderate injury.

FAILURE TO FOLLOW DANGER, WARNING, AND CAUTION MESSAGES COULD RESULT IN DEATH OR SERIOUS INJURY.

Machine safety

NOTICE: *Notice indicates a situation that, if not avoided, could result in machine or property damage.*

Throughout this manual you will find the signal word **Notice** followed by special instructions to prevent machine or property damage. The word **Notice** is used to address practices not related to personal safety.

Information

NOTE: *Note indicates additional information that clarifies steps, procedures, or other information in this manual.*

Throughout this manual you will find the word **Note** followed by additional information about a step, procedure, or other information in the manual. The word **Note** is not intended to address personal safety or property damage.

Safety rules

General safety rules

Use caution when you operate the machine on slopes. Raised equipment, full tanks and other loads will change the center of gravity of the machine. The machine can tip or roll over when near ditches and embankments or uneven surfaces.

Never permit anyone other than the operator to ride on the machine.

Never operate the machine under the influence of alcohol or drugs, or while you are otherwise impaired.

Pay attention to overhead power lines and hanging obstacles. High voltage lines may require significant clearance for safety.

Hydraulic oil or diesel fuel leaking under pressure can penetrate the skin, causing serious injury or infection.

- DO NOT use your hand to check for leaks. Use a piece of cardboard or paper.
- Stop the engine, remove the key, and relieve the pressure before you connect or disconnect fluid lines.
- Make sure that all components are in good condition. Tighten all connections before you start the engine or pressurize the system.
- If hydraulic fluid or diesel fuel penetrates the skin, seek medical attention immediately.
- Continuous long term contact with hydraulic fluid may cause skin cancer. Avoid long term contact and wash the skin promptly with soap and water.

Keep clear of moving parts. Loose clothing, jewelry, watches, long hair, and other loose or hanging items can become entangled in moving parts.

Wear protective equipment when appropriate.

DO NOT attempt to remove material from any part of the machine while it is being operated or while components are in motion.

Make sure that all guards and shields are in good condition and properly installed before you operate the machine. Never operate the machine with shields removed. Always close access doors or panels before you operate the machine.

Dirty or slippery steps, ladders, walkways, and platforms can cause falls. Make sure these surfaces remain clean and clear of debris.

A person or pet within the operating area of a machine can be struck or crushed by the machine or its equipment. DO NOT allow anyone to enter the work area.

Raised equipment and/or loads can fall unexpectedly and crush persons underneath. Never allow anyone to enter the area underneath raised equipment during operation.

Never operate the engine in enclosed spaces as harmful exhaust gases may build up.

Before you start the machine, be sure that all controls are in neutral or park lock position.

Always keep windows, mirrors, and all lighting clean to provide the best possible visibility while you operate the machine.

Operate controls only when seated in the operator's seat, except for those controls expressly intended for use from other locations.

Before you leave the machine:

1. Park the machine on a firm, level surface.
2. Put all controls in neutral or park lock position.
3. Engage the parking brake. Use wheel chocks if required.
4. Lower all hydraulic equipment — Implements, header, etc.
5. Turn off the engine and remove the key.

When, due to exceptional circumstances, you would decide to keep the engine running after you leave the operator's station, then you must follow these precautions:

1. Bring the engine to low idle speed.
2. Disengage all drive systems.

3. **⚠ WARNING**

**Some components may continue to run down after you disengage drive systems.
Make sure all drive systems are fully disengaged.
Failure to comply could result in death or serious injury.**

W0113A

Shift the transmission into neutral.

4. Apply the parking brake.

⚠ General maintenance safety ⚠

Keep the area used for servicing the machine clean and dry. Clean up spilled fluids.

Service the machine on a firm, level surface.

Install guards and shields after you service the machine.

Close all access doors and install all panels after servicing the machine.

Do not attempt to clean, lubricate, clear obstructions, or make adjustments to the machine while it is in motion or while the engine is running.

Always make sure that working area is clear of tools, parts, other persons and pets before you start operating the machine.

Unsupported hydraulic cylinders can lose pressure and drop the equipment, causing a crushing hazard. Do not leave equipment in a raised position while parked or during service, unless the equipment is securely supported.

Jack or lift the machine only at jack or lift points indicated in this manual.

Incorrect towing procedures can cause accidents. When you tow a disabled machine follow the procedure in this manual. Use only rigid tow bars.

Stop the engine, remove the key, and relieve pressure before you connect or disconnect fluid lines.

Stop the engine and remove the key before you connect or disconnect electrical connections.

Scalding can result from incorrect removal of coolant caps. Cooling systems operate under pressure. Hot coolant can spray out if you remove a cap while the system is hot. Allow the system to cool before you remove the cap. When you remove the cap, turn it slowly to allow pressure to escape before you completely remove the cap.

Replace damaged or worn tubes, hoses, electrical wiring, etc.

The engine, transmission, exhaust components, and hydraulic lines may become hot during operation. Take care when you service such components. Allow surfaces to cool before you handle or disconnect hot components. Wear protective equipment when appropriate.

When welding, follow the instructions in the manual. Always disconnect the battery before you weld on the machine. Always wash your hands after you handle battery components.

INTRODUCTION

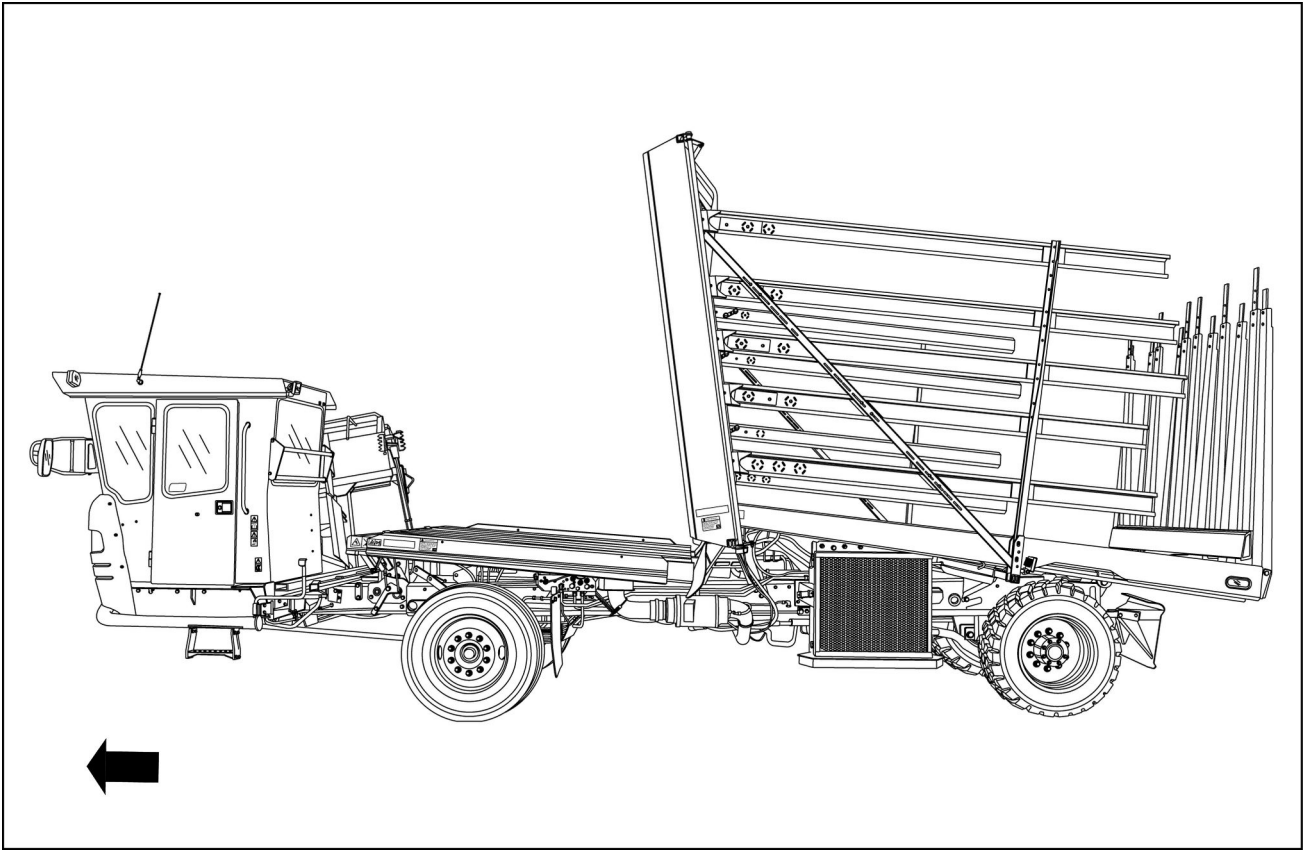

NHIL17BW00668FA 2

Left-hand side view

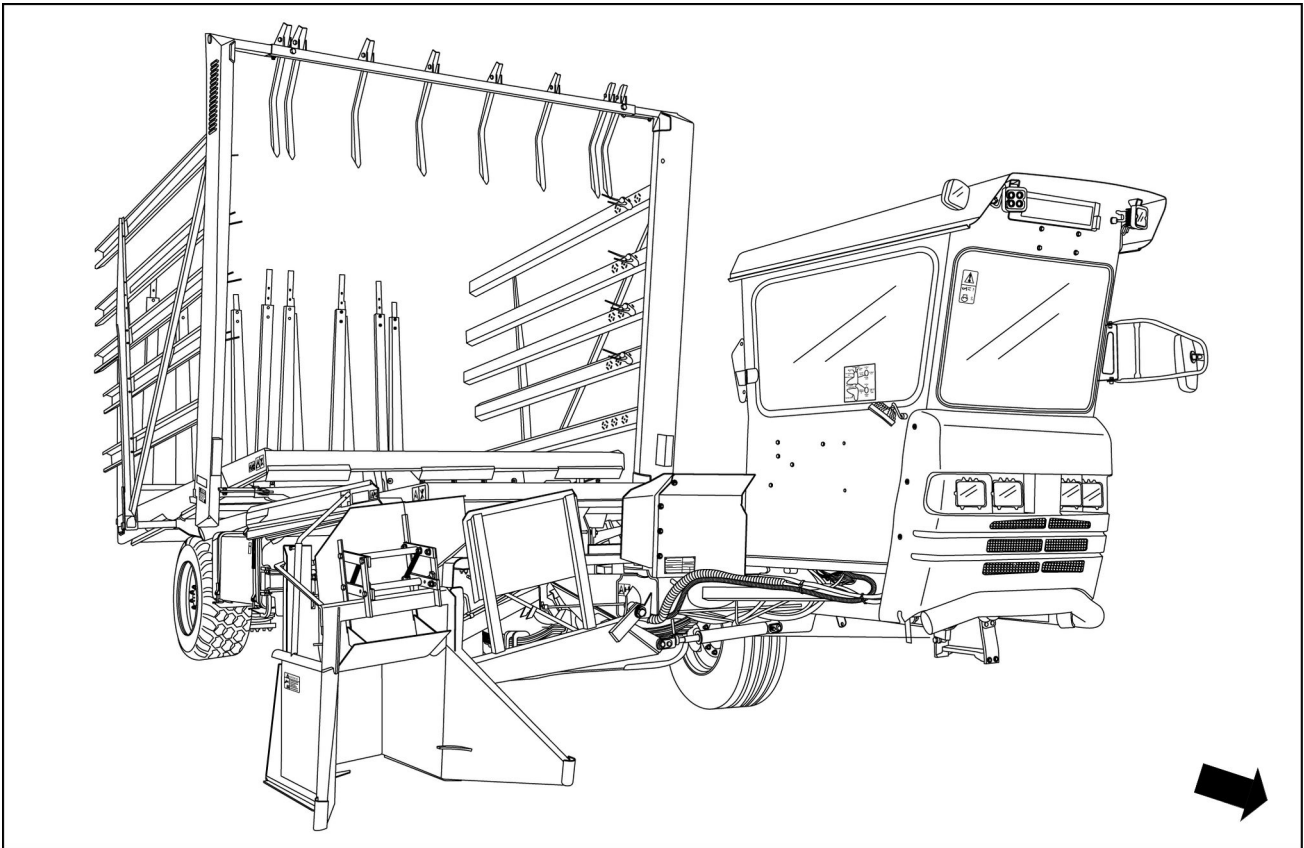

NHIL17BW00665FA 3

Front view



SERVICE MANUAL

Engine

StackCruiser® 102

StackCruiser® 103

StackCruiser® 105

Engine - Technical Data - Recommended engine oil operating temperature ranges

NEW HOLLAND recommends the use of **NEW HOLLAND AMBRA UNITEK MASTERGOLD SBL CJ-4** engine oil in all Tier 4B (final) engines. This multi-viscosity engine oil will lubricate the engine correctly under all operating conditions. **NEW HOLLAND AMBRA UNITEK MASTERGOLD SBL CJ-4** engine oil has a maximum service change interval of **600 h**

Use **NEW HOLLAND AMBRA MASTERGOLD™ HSP ENGINE OIL** in the engine is also acceptable. **NEW HOLLAND AMBRA MASTERGOLD™ HSP ENGINE OIL** has a maximum service change interval of **400 h**.

Engine oils meeting the **API CJ-4** performance requirements are also acceptable to use in Tier 4B (final) engines. The maximum service change interval for an **API CJ-4** engine oil is **300 h**.

NEW HOLLAND engine oils exceed the **API CJ-4** performance requirements.

See the following chart for the recommended viscosity at varying ambient air temperature ranges.

NOTE: Do not add performance additives or other oil additive products in the engine crankcase. NEW HOLLAND developed the given oil change interval chart from tests with NEW HOLLAND lubricants.

For machines using Tier 4B (final) engines

(H) NEW HOLLAND AMBRA UNITEK MASTERGOLD SSL CJ-4 SAE 0W-40										
(H) 0W-40 API CJ-4*										
(H) NEW HOLLAND AMBRA UNITEK MASTERGOLD SBL CJ-4 SAE 10W-40										
(H) 10W-40 API CJ-4*										
(H) NEW HOLLAND AMBRA UNITEK CJ-4 ENGINE OIL SAE 15W-40**										
(H) 15W-40* API CJ-4*										
-40 °C -40 °F	-30 °C -22 °F	-20 °C -4 °F	-10 °C 14 °F	0 °C 32 °F	10 °C 50 °F	20 °C 68 °F	30 °C 86 °F	40 °C 104 °F	50 °C 122 °F	
<p>(H) NEW HOLLAND recommends the use of an engine oil pan heater or coolant block heater within this range</p> <p>* Maximum engine oil service change interval is 300 h</p> <p>**Maximum engine oil service change interval is 400 h</p>										

Engine - Overview

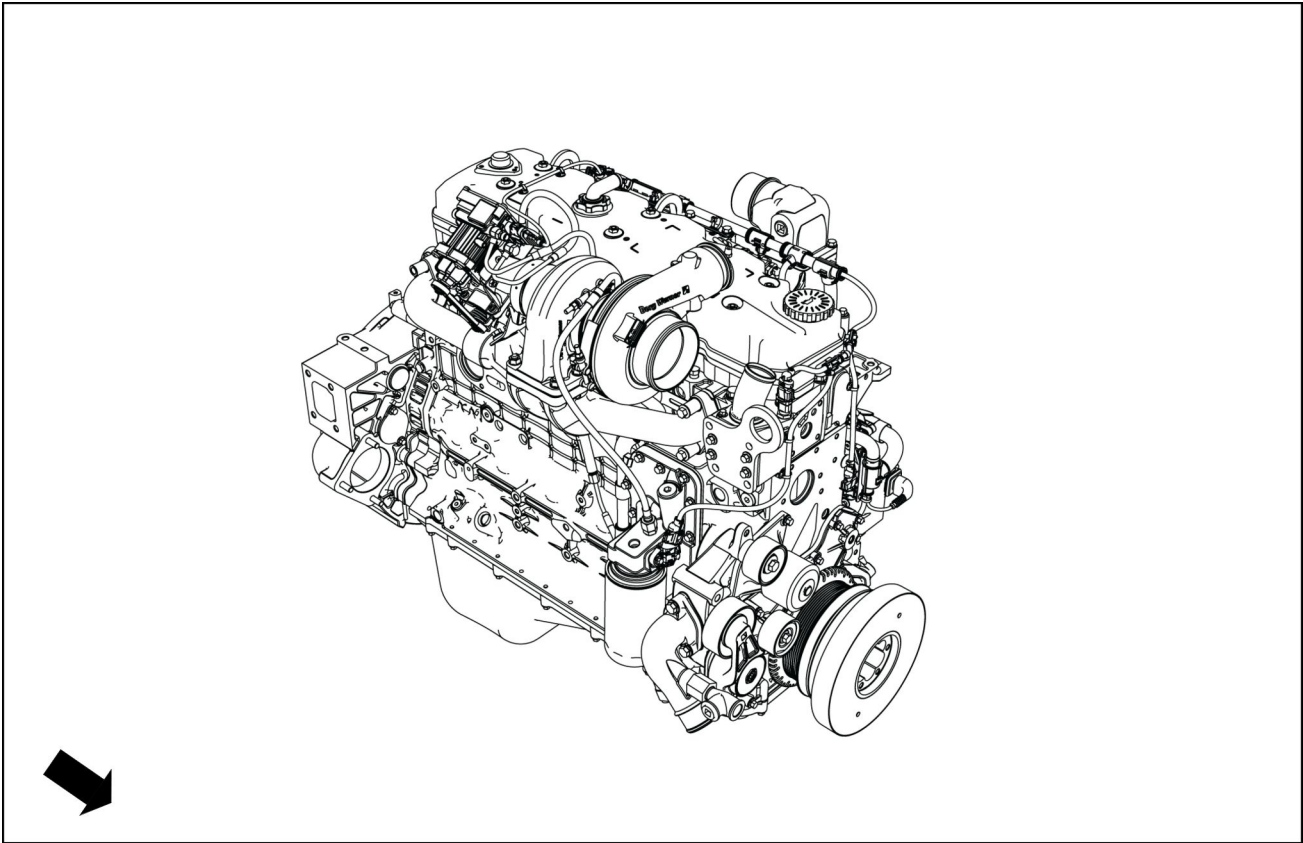

NHIL17BW00490FA 1

The NEF 6 Tier IVB engine is a 6-cylinder turbocharged and after cooled unit, having a bore of **104 mm (4.4 in)** and a stroke of **132 mm (5.0 in)** which generates a displacement of **6.7 L (408.9 in³)** .

The engine uses an electronically controlled high-pressure injection pump designed to meet the current emission regulations.

All engines feature cross flow cylinder heads, with the inlet and exhaust manifolds on opposite sides of the cylinder head. The fuel and air combustion process, takes place in the specially designed bowl in the crown of the pistons.

NOTE: *The front of the engine is the water pump end. The rear of the engine is the flywheel end. To determine the right-hand and left-hand of the engine, stand at the rear of the engine looking at the flywheel end with the water pump end away from you.*

Engine - Component localization

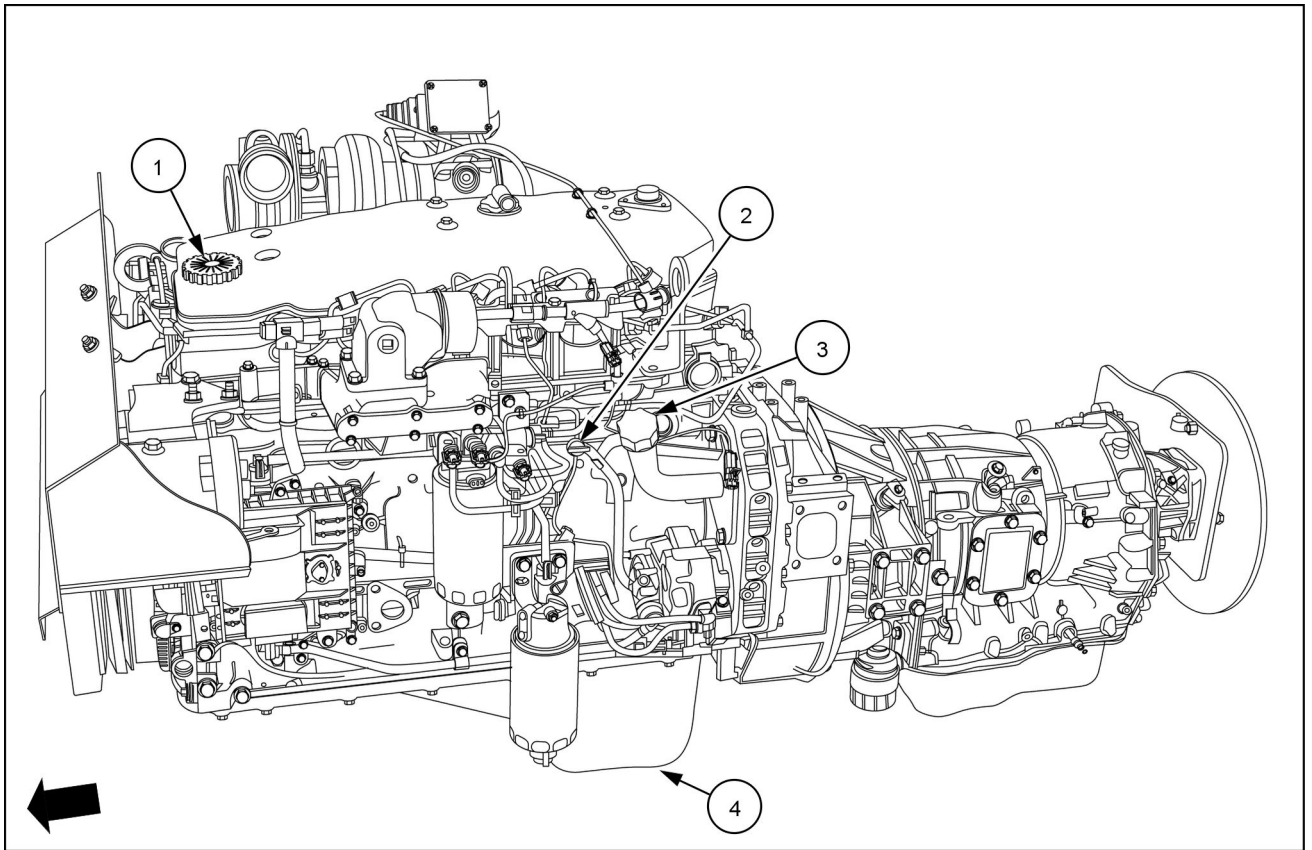

NHIL17BW00315FA 1

Ref.	Component
(1)	Valve cover engine oil cap (DO NOT fill engine oil here)
(2)	Dipstick, engine oil level (see Engine - Level make up - Engine oil (10.001))
(3)	Engine oil fill tube (see Engine - Change fluid (10.001))
(4)	Engine oil drain plug (see Engine - Change fluid (10.001))



Suggest:

If the above button click is invalid.

Please download this document

first, and then click the above link

to download the complete manual.

Thank you so much for reading

Engine - Level make up - Engine oil

⚠ DANGER

Avoid injury!

Do not raise the load rack to the vertical position for servicing the machine unless the rolling rack is to the rear of the load rack, or is secured to the front of the load rack with a chain.

Failure to comply will result in death or serious injury.

D0126A

Park the bale wagon on a level surface.

Turn the engine off.

Allow the engine to remain off for a minimum of five minutes.

1. Remove the dipstick (1) .
2. Wipe the engine oil off of the dipstick with a clean cloth.
3. Fully reinsert the dipstick into the engine.
4. Pull the dipstick out and check the engine oil level.
The engine oil level should be between the MIN and MAX indicator lines.

NOTICE: Do not operate the engine with the engine oil level below the MIN indicator line.

NOTICE: Do not fill above the MAX indicator line. The excess engine oil will burn off and give a false impression of engine oil consumption.

5. Remove the filler cap (2) .
6. Add fresh engine oil as required.

NOTE: Add engine oil to the engine SLOWLY as the engine oil cannot drain down into the crankcase very quickly.

7. Repeat Steps 2 through 6 until the engine oil is within the MIN and MAX indicator lines.

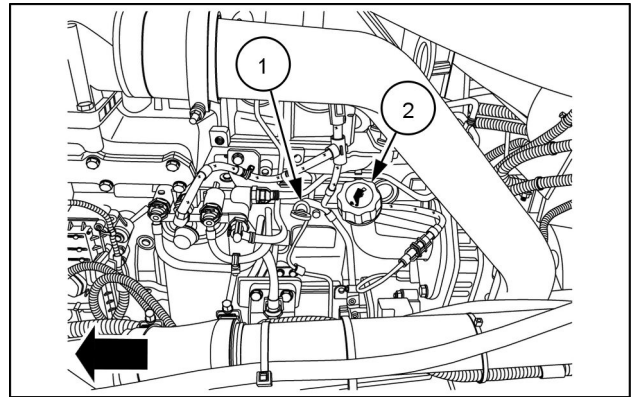

NHIL17BW00014AA 1

<https://www.ebooklibonline.com>

Hello dear friend!

Thank you very much for reading.

Enter the link into your browser.

The full manual is available for immediate download.

<https://www.ebooklibonline.com>