

LW 170.B Wheel Loader Service Manual 6-49712

Table of Contents

Description	Section No.	Form No.
General		
	Tab 1	
Section Index - General		6-49780
Standard Torque Specifications	1001	6-49790
Fluids and Lubricants	1002	6-49801
Metric Conversion Chart	1003	6-49810
Engines		
	Tab 2	
Section Index - Engines		6-49820
Engine and Radiator Removal and Installation	2000	6-49830
Stall Tests	2002	6-49841
After Cooler	2003	6-49850
Engine		6-49750
Fuel System		
	Tab 3	
Section Index - Fuel System		6-49860
For Fuel System Repair, See the Engine Service Manual		
Electrical		
	Tab 4	
Section Index - Electrical		6-49870
Removal and Installation of Starter and Alternator	4001	6-49880
Electrical Specifications and Troubleshooting	4002	6-49891
Batteries	4003	6-49900
Information and Diagnostic Center	4005	6-49921

Reprinted

LW 170.B Wheel Loader Service Manual 6-49712

Table of Contents

Description	Section No.	Form No.
Steering		
	Tab 5	
Section Index - Steering		6-49950
Removal and Installation of Steering Components	5001	6-49960
Steering Specifications, Pressure Checks, and Troubleshooting	5002	6-49970
Steering Control Valve	5003	6-49980
Steering Priority Valve	5004	6-49990
Steering Cylinders	5005	6-72000
Center Pivot	5006	6-72010
Auxiliary Steering Motor and Pump	5007	6-72020
Power Train		
	Tab 6	
Section Index - Power Train		6-72030
Removal and Installation of Power Train Components	6001	6-72040
Transmission Specifications, Pressure Checks, and Troubleshooting	6002	6-72050
Transmission	6003	6-72060
Front Axle	6004	6-72070
Rear Axle	6004	6-72080
Drive Shafts, Center Bearing, and Universal Joints	6005	6-72090
Wheels and Tires	6006	6-72100
Transmission Control Valve	6007	6-72110
Brakes		
	Tab 7	
Section Index - Brakes		6-72120
Removal and Installation of Brake Components	7001	6-72130
Hydraulic Brake Troubleshooting	7002	6-72141
Parking Brake	7008	6-72160
Hydraulics		
	Tab 8	
Section Index - Hydraulics		6-72170
Removal and Installation of Hydraulic Components	8001	6-72182
Hydraulic Specifications, Troubleshooting, and Pressure Checks	8002	6-72192
Cleaning the Hydraulic System	8003	6-72200
Loader Control Valve	8005	6-72220
Cylinders	8006	6-72231
Coupler Solenoid Locking Valve	8007	6-72240
Pilot Pressure Accumulator and Ride Control Accumulator	8013	6-72260
Ride Control Valve	8014	6-72271

LW 170.B Wheel Loader Service Manual 6-49712

Table of Contents

Description	Section No.	Form No.
Mounted Equipment		Tab 9
Section Index - Mounted Equipment		6-72280
Air Conditioning Troubleshooting and System Checks For Systems with HFC-134a Refrigerant	9002	6-72290
Air Conditioner System Service	9003	6-72300
Removal and Installation of Air Conditioning Components For Systems with HFC-134a Refrigerant	9004	6-72310
Loader	9006	6-72321
ROPS Cab and ROPS Canopy	9007	6-72330
Cab Glass Installation	9010	6-72340
Electrical Schematic Foldouts and Hydraulic Schematic Foldout		In Rear Pocket
		6-49770

NOTE: CNH America LLC reserves the right to make improvements in design or changes in specifications at any time without incurring any obligation to install them on units previously sold.

<https://www.ebooklibonline.com>

Hello dear friend!

Thank you very much for reading.

Enter the link into your browser.

The full manual is available for immediate download.

<https://www.ebooklibonline.com>

SECTION INDEX

GENERAL

Section Title	Section Number
Standard Torque Specifications	1001
Fluids and Lubricants	1002
Metric Conversion Chart	1003

Section 1001

GENERAL TORQUE SPECIFICATIONS

TORQUE SPECIFICATIONS - DECIMAL HARDWARE

Use the torques in this chart when special torques are not given. These torques apply to fasteners with both UNC and UNF threads as received from suppliers dry, or when lubricated with engine oil. Not applicable if special graphities, Molydisulfide greases, or other extreme pressure lubricants are used.

Grade 5 Bolts, Nuts, and Studs		
		
Size	Pound-Inches	Newton metres
1/4 inch	108 to 132	12 to 15
5/16 inch	204 to 252	23 to 28
3/8 inch	420 to 504	48 to 57
Size	Pound-Feet	Newton metres
7/16 inch	54 to 64	73 to 87
1/2 inch	80 to 96	109 to 130
9/16 inch	110 to 132	149 to 179
5/8 inch	150 to 180	203 to 244
3/4 inch	270 to 324	366 to 439
7/8 inch	400 to 480	542 to 651
1.0 inch	580 to 696	787 to 944
1-1/8 inch	800 to 880	1085 to 1193
1-1/4 inch	1120 to 1240	1519 to 1681
1-3/8 inch	1460 to 1680	1980 to 2278
1-1/2 inch	1940 to 2200	2631 to 2983

Grade 8 Bolts, Nuts, and Studs		
		
Size	Pound-Inches	Newton metres
1/4 inch	144 to 180	16 to 20
5/16 inch	288 to 348	33 to 39
3/8 inch	540 to 648	61 to 73
Size	Pound-Feet	Newton metres
7/16 inch	70 to 84	95 to 114
1/2 inch	110 to 132	149 to 179
9/16 inch	160 to 192	217 to 260
5/8 inch	220 to 264	298 to 358
3/4 inch	380 to 456	515 to 618
7/8 inch	600 to 720	814 to 976
1.0 inch	900 to 1080	1220 to 1465
1-1/8 inch	1280 to 1440	1736 to 1953
1-1/4 inch	1820 to 2000	2468 to 2712
1-3/8 inch	2380 to 2720	3227 to 3688
1-1/2 inch	3160 to 3560	4285 to 4827
NOTE: Use thick nuts with Grade 8 bolts.		

TORQUE SPECIFICATIONS - METRIC HARDWARE

Use the following torques when specifications are not given.

These values apply to fasteners with coarse threads as received from supplier, plated or unplated, or when lubricated with engine oil. These values do not apply if graphite or Molydisulfide grease or oil is used.

Grade 8.8 Bolts, Nuts, and Studs		
		
Size	Pound-Inches	Newton metres
M4	24 to 36	3 to 4
M5	60 to 72	7 to 8
M6	96 to 108	11 to 12
M8	228 to 276	26 to 31
M10	456 to 540	52 to 61
Size	Pound-Feet	Newton metres
M12	66 to 79	90 to 107
M14	106 to 127	144 to 172
M16	160 to 200	217 to 271
M20	320 to 380	434 to 515
M24	500 to 600	675 to 815
M30	920 to 1100	1250 to 1500
M36	1600 to 1950	2175 to 2600

Grade 10.9 Bolts, Nuts, and Studs		
		
Size	Pound-Inches	Newton metres
M4	36 to 48	4 to 5
M5	84 to 96	9 to 11
M6	132 to 156	15 to 18
M8	324 to 384	37 to 43
Size	Pound-Feet	Newton metres
M10	54 to 64	73 to 87
M12	93 to 112	125 to 150
M14	149 to 179	200 to 245
M16	230 to 280	310 to 380
M20	450 to 540	610 to 730
M24	780 to 940	1050 to 1275
M30	1470 to 1770	2000 to 2400
M36	2580 to 3090	3500 to 4200

Grade 12.9 Bolts, Nuts, and Studs

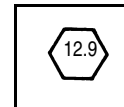

Usually the torque values specified for grade 10.9 fasteners can be used satisfactorily on grade 12.9 fasteners.

TORQUE SPECIFICATIONS - STEEL HYDRAULIC FITTINGS

Tube OD Hose ID	Thread Size	Pound- Inches	Newton metres
37 Degree Flare Fitting			
1/4 inch 6.4 mm	7/16-20	72 to 144	8 to 16
5/16 inch 7.9 mm	1/2-20	96 to 192	11 to 22
3/8 inch 9.5 mm	9/16-18	120 to 300	14 to 34
1/2 inch 12.7 mm	3/4-16	180 to 504	20 to 57
5/8 inch 15.9 mm	7/8-14	300 to 696	34 to 79
Tube OD Hose ID	Thread Size	Pound- Inches	Newton metres
3/4 inch 19.0 mm	1-1/16-12	40 to 80	54 to 108
7/8 inch 22.2 mm	1-3/16-12	60 to 100	81 to 135
1.0 inch 25.4 mm	1-5/16-12	75 to 117	102 to 158
1-1/4 inch 31.8 mm	1-5/8-12	125 to 165	169 to 223
1-1/2 inch 38.1 mm	1-7/8-12	210 to 250	285 to 338

Tube OD Hose ID	Thread Size	Pound- Inches	Newton metres
Straight Threads with O-ring			
1/4 inch 6.4 mm	7/16-20	144 to 228	16 to 26
5/16 inch 7.9 mm	1/2-20	192 to 300	22 to 34
3/8 inch 9.5 mm	9/16-18	300 to 480	34 to 54
1/2 inch 12.7 mm	3/4-16	540 to 804	57 to 91
Tube OD Hose ID	Thread Size	Pound- Inches	Newton metres
5/8 inch 15.9 mm	7/8-14	58 to 92	79 to 124
3/4 inch 19.0 mm	1-1/16-12	80 to 128	108 to 174
7/8 inch 22.2 mm	1-3/16-12	100 to 160	136 to 216
1.0 inch 25.4 mm	1-5/16-12	117 to 187	159 to 253
1-1/4 inch 31.8 mm	1-5/8-12	165 to 264	224 to 357
1-1/2 inch 38.1 mm	1-7/8-12	250 to 400	339 to 542

Split Flange Mounting Bolts		
Size	Pound- Inches	Newton metres
5/16-18	180 to 240	20 to 27
3/8-16	240 to 300	27 to 34
7/16-14	420 to 540	47 to 61
Size	Pound- Feet	Newton metres
1/2-13	55 to 65	74 to 88
5/8-11	140 to 150	190 to 203

TORQUE SPECIFICATIONS - STEEL HYDRAULIC FITTINGS

Nom. SAE Dash Size	Tube OD	Thread Size	Pound-Inches	Newton metres	Thread Size	Pound-Inches	Newton metres
O-ring Face Seal End					O-ring Boss End Fitting or Lock Nut		
-4	1/4 inch 6.4 mm	9/16-18	120 to 144	14 to 16	7/16-20	204 to 240	23 to 27
-6	3/8 inch 9.5 mm	11/16-16	216 to 240	24 to 27	9/16-18	300 to 360	34 to 41
-8	1/2 inch 12.7 mm	13/16-16	384 to 480	43 to 54	3/4-16	540 to 600	61 to 68
					Thread Size	Pound-Inches	Newton metres
-10	5/8 inch 15.9 mm	1-14	552 to 672	62 to 76	7/8-14	60 to 65	81 to 88
Nom. SAE Dash Size	Tube OD	Thread Size	Pound-Inches	Newton metres	1-1/16-12	85 to 90	115 to 122
					1-3/16-12	95 to 100	129 to 136
-12	3/4 inch 19.0 mm	1-3/16-12	65 to 80	90 to 110	1-5/16-12	115 to 125	156 to 169
-14	7/8 inch 22.2 mm	1-3/16-12	65 to 80	90 to 110	1-5/8-12	150 to 160	203 to 217
-16	1.0 inch 25.4 mm	1-7/16-12	92 to 105	125 to 140	1-7/8-12	190 to 200	258 to 271
-20	1-1/4 inch 31.8 mm	1-11/16-12	125 to 140	170 to 190			
-24	1-1/2 inch 38.1 mm	2-12	150 to 180	200 to 254			

Section 2000

ENGINE AND RADIATOR REMOVAL AND INSTALLATION

TABLE OF CONTENTS

Engine	3
Removal	3
Installation	10
RADIATOR	17
Removal	17
Installation	19

ENGINE

Removal

STEP 1



BD03A040

Park machine on a level surface and lower bucket to ground. Put articulation lock in LOCKED position.

STEP 2

Stop engine. Actuate brake pedal several times to discharge brake accumulators. Put key switch in ON position and move loader control lever back and forth at least 30 times to release any pressure from hydraulic circuit. Put key switch in OFF position.

STEP 3

Slowly loosen the filler cap for hydraulic reservoir to release air pressure in hydraulic reservoir.

STEP 4

Put master disconnect switch in OFF position. Disconnect batteries from the machine.

STEP 5



BD03N043

Loosen clamps and remove air filter intake from air filter.

STEP 6

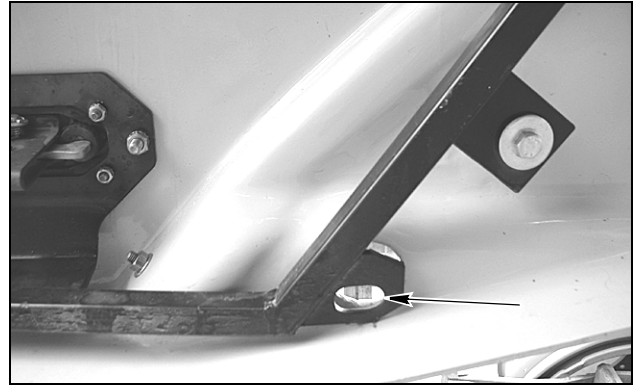

BD03J111

Open the engine compartment side panel, attach a lifting eye to the hole in the lower portion of the panel.

STEP 7



BD03N045

Attach lifting straps to the hinge side of the hood, attach suitable lifting equipment to the straps and take up slack in the straps.

STEP 8

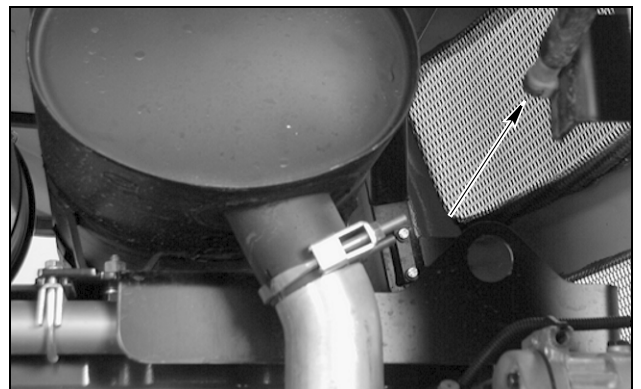

BD03J112

Disconnect the gas cylinder from the side panel and hood.

STEP 9

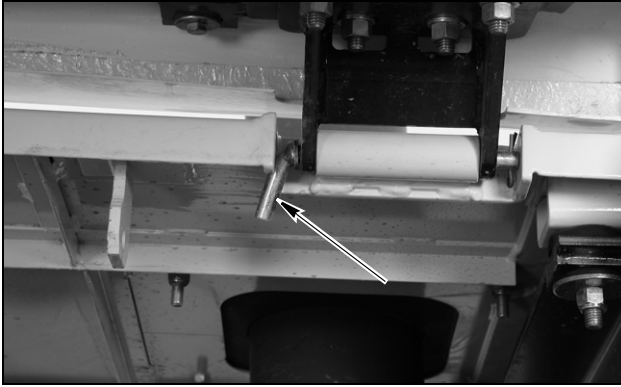

BD03N046

Remove hinge pins, remove panel from machine.

STEP 10

Repeat steps 6 through 9 for the other side panel.

STEP 11

Attach lifting straps to the center hood section.

STEP 12

Connect lifting equipment to the lifting straps. Take up all slack in strap connected to hood.

STEP 13



BD03J115

Remove two nuts and bolts and four washers securing the rear of the hood.

STEP 14

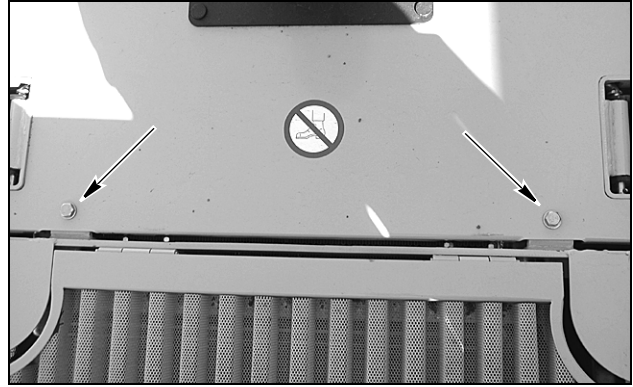

BD03J116

Remove the two front bolts and washers securing the front of the hood.

STEP 15

Carefully raise and remove hood from loader. Lower hood onto suitable platform and disconnect lifting equipment.

STEP 16

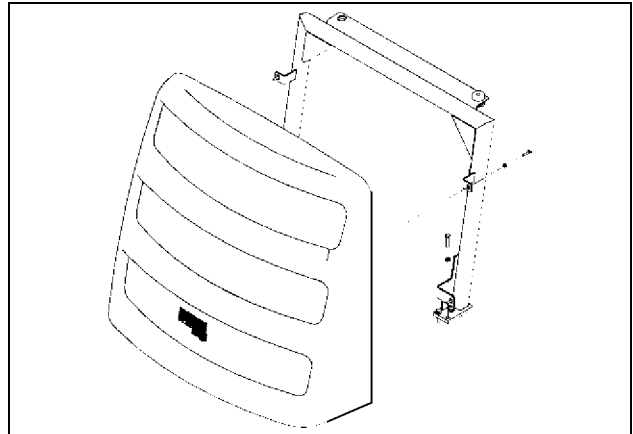

BC03J056

Remove the four rear grill mounting bolts, remove the grill. Remove the six rear grill frame mounting bolts and nuts, remove the frame.

STEP 17

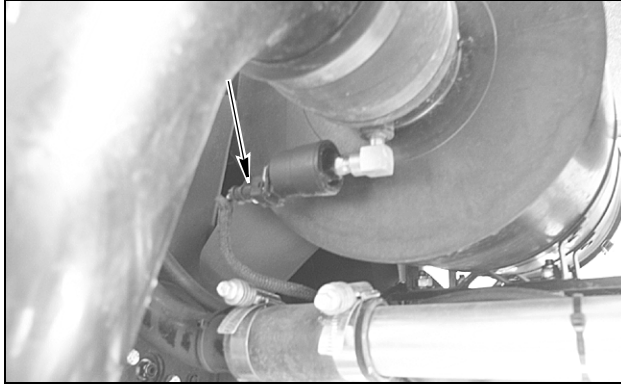

BD03A224

Tag and disconnect engine wiring harness connector from air filter restriction switch.

STEP 18

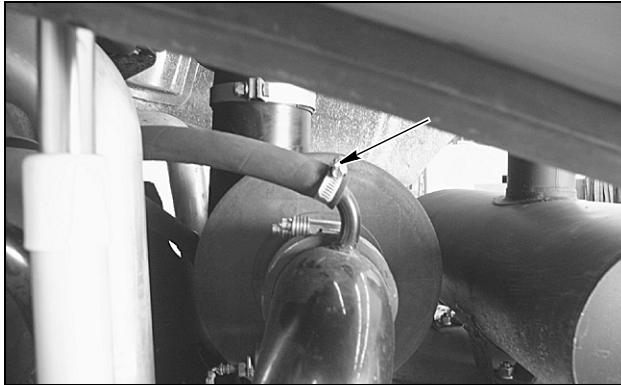

BD03A225

Loosen clamp on air cleaner intake hose and remove the crankcase ventilation hose.

STEP 19

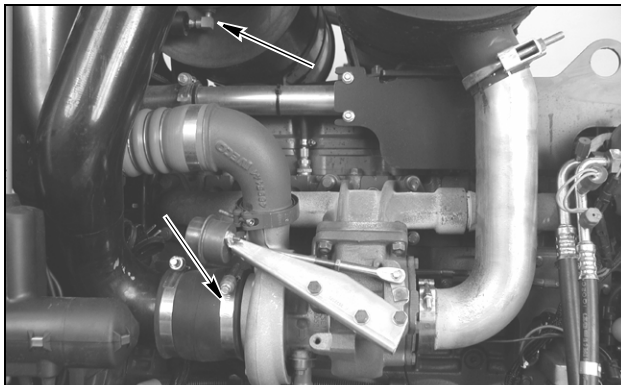

BD03A137

Loosen clamps on turbocharger and air cleaner, remove the intake hose.

STEP 20

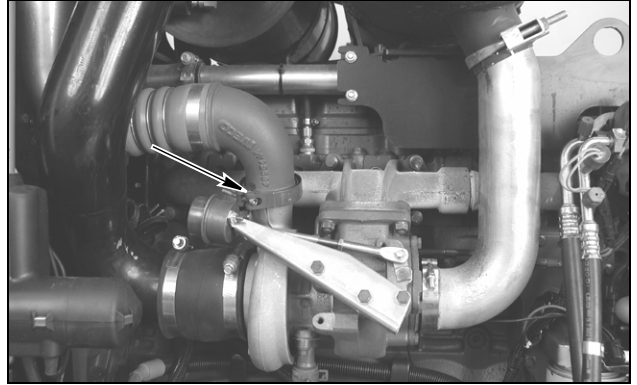

BD03A137

Loosen the clamp on the turbocharger for the after cooler inlet hose.

STEP 21



BD03A115

Loosen the clamp on the after cooler and remove the after cooler inlet hose from the machine.

STEP 22

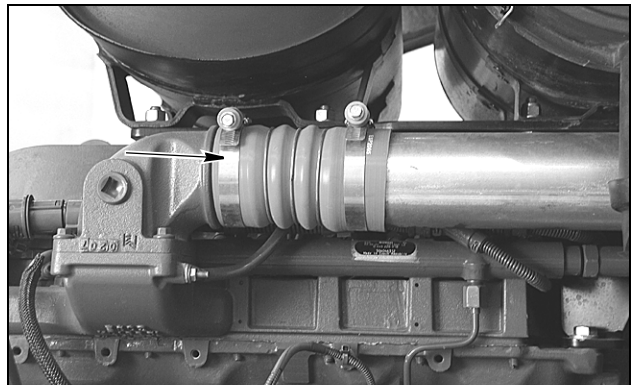

BD03A119

Loosen the clamps on the intake and after cooler, remove cooler output hose.

STEP 23



BD02N160

Put a 25.5 liter (6.75 gallon) container below radiator drain. Remove radiator cap. Remove cap and drain coolant into container. Install cap after coolant has drained. Install radiator cap.

STEP 24

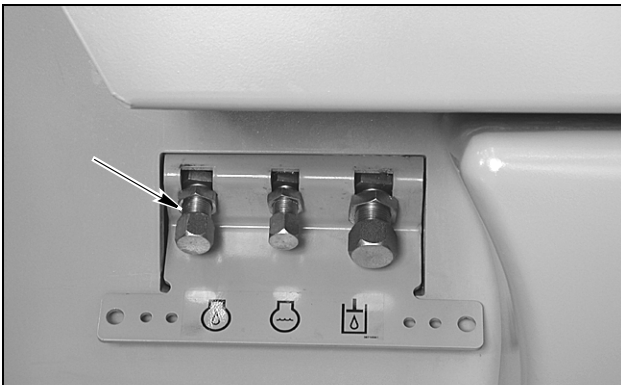

BD02N160

Put a 14.2 liter (15 U.S. quarts) container below engine oil drain. Remove cap and drain oil into container. Install cap after oil has drained.

NOTE: After draining oil disconnect drain hose from frame for removal with engine.

STEP 25

Remove the four mounting bolts from the belt cover, remove the cover.

NOTE: After removing the belt cover remove the cover mounting brackets from the machine frame.

STEP 26

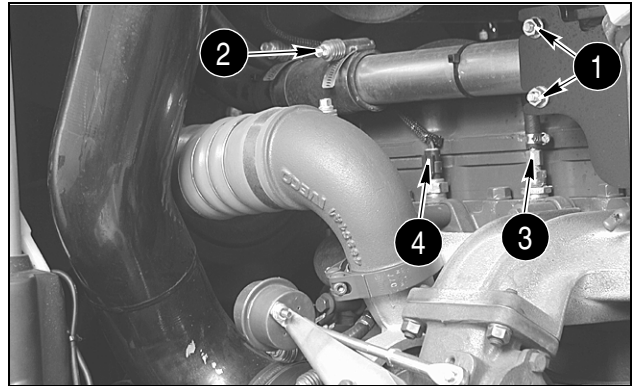

BD03A147

Loosen and remove the two nuts (1) and washers from the upper coolant pipe support clamp, remove the clamp. Loosen the coolant pipe clamp (2). Disconnect the engine coolant vent line (3). Tag and disconnect the coolant temperature sending unit (4).

STEP 27

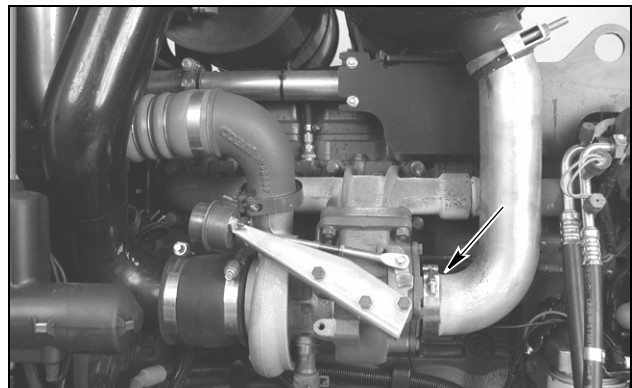

BD03A137

Loosen the exhaust clamp from the turbocharger.

STEP 28

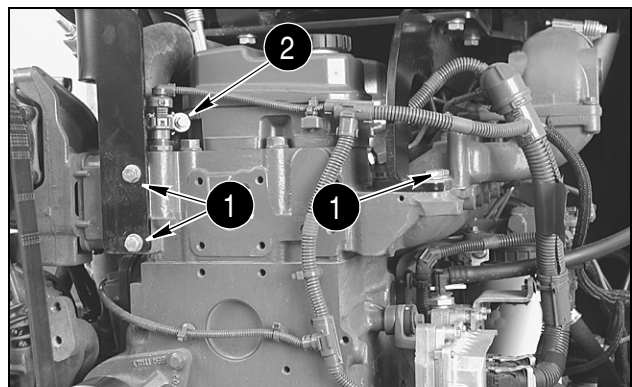

BD03A140

Loosen the upper coolant line hose clamp (2), remove the hose and pipe from the machine. Attach suitable lifting equipment to the muffler and air cleaner bracket. Remove the four front muffler and air cleaner bracket mounting bolts (1).

STEP 29

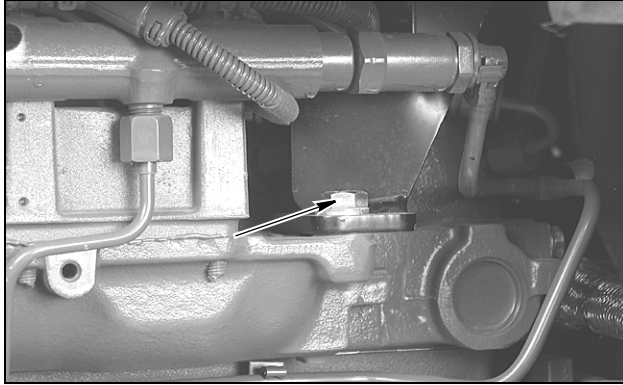

BD03A145

Remove the rear bracket mounting bolt. Remove two brace mounting bolts from the bell housing. Remove the bracket, muffler, and air cleaner from the machine.

NOTE: Make sure fuel lines and electrical wiring do not become entangled in the bracket during removal.

STEP 30

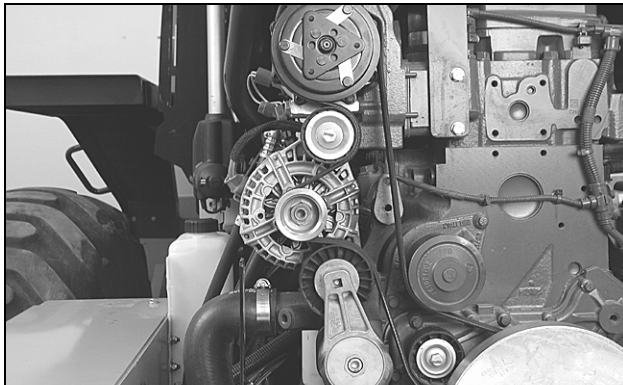

BD03A134

Remove the drive belt from the engine.

STEP 31

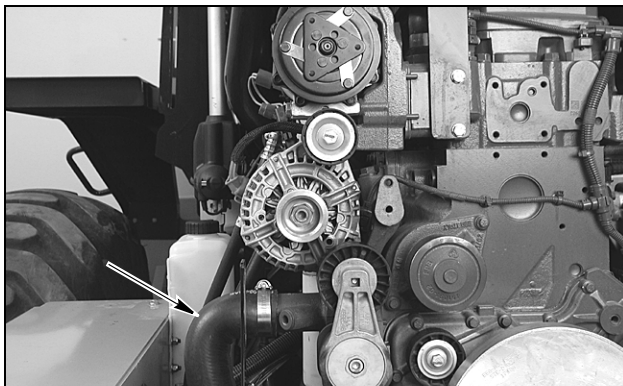

BD03A132

Loosen clamps and remove lower cooler hose from the engine.

STEP 32

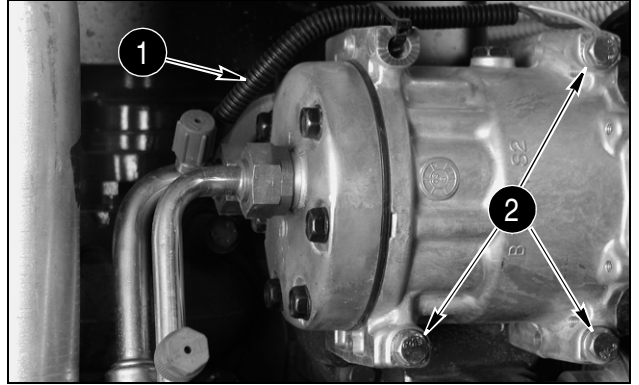

BD03N048

If loader is equipped with air conditioning, identify, tag, and disconnect the engine wiring harness connectors from air compressor clutch connector (1). Remove the three mounting bolts (2) for the compressor and set the compressor on the left battery cover.

STEP 33

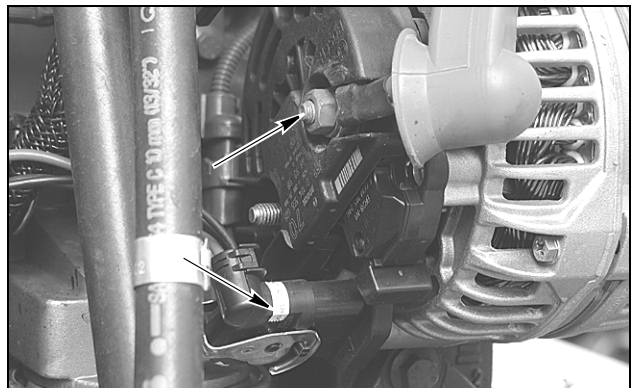

BD03A130

Tag and disconnect the wiring from the alternator.

STEP 34



BD03A127

Remove the rubber cap from the starter solenoid cover.



Suggest:

If the above button click is invalid.

Please download this document

first, and then click the above link

to download the complete manual.

Thank you so much for reading

STEP 35

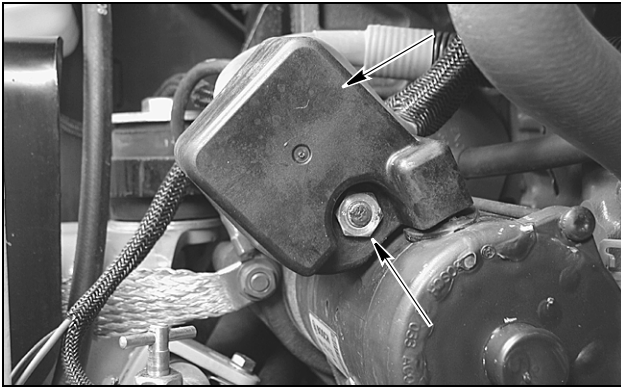

BD03A126

Remove the starter solenoid cover mounting nut, remove the cover.

STEP 36

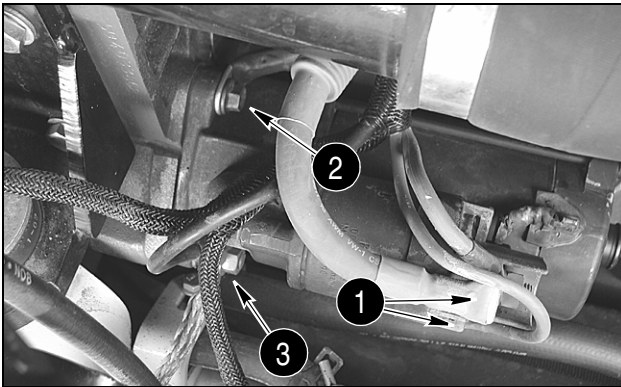

BD03A123

Tag and remove the wires from the starter solenoid (1), remove the ground cable (2), and ground strap (3) from the starter.

STEP 37

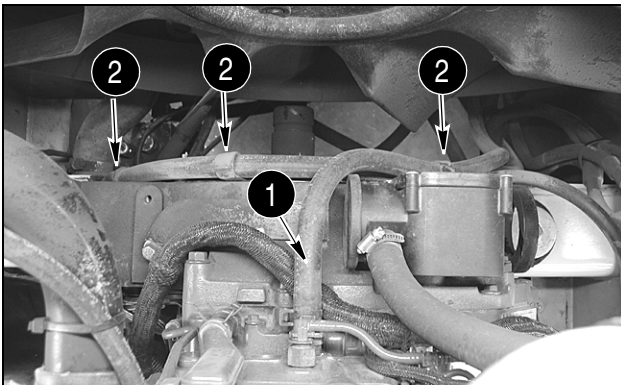

BD03A215

Remove the heater hose (1) from the rear of the engine, remove the clamp bolts and clamps (2) from the bell housing.

STEP 38

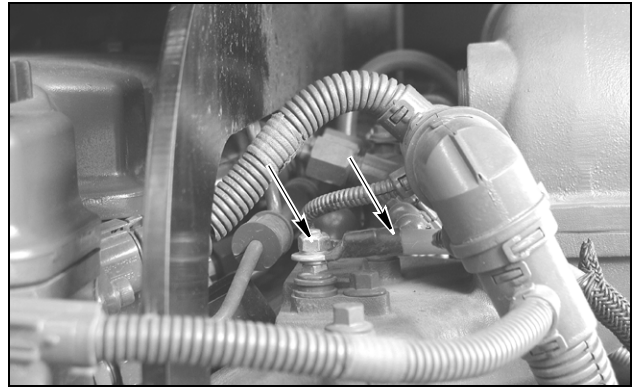

BD03A144

Tag and remove the grid heater cable.

STEP 39

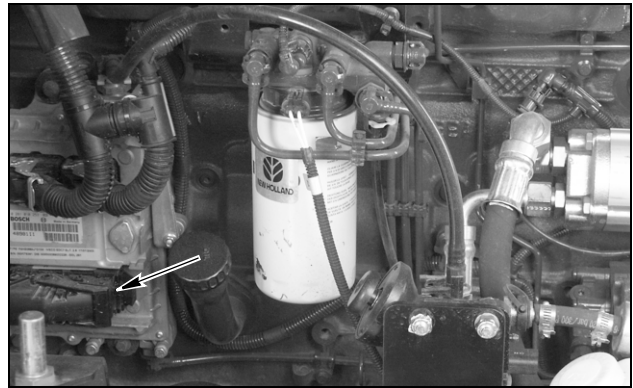

BD03N044

Disconnect the wiring harness from the EDC 7 controller.

NOTE: *Lifting up on the lever will release the connector from the controller.*

STEP 40

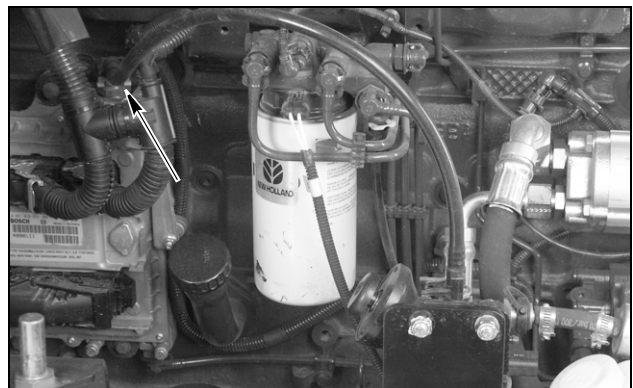

BD03N044

Remove the fuel line from the top of the EDC 7 controller, plug the line and cap the fitting.

<https://www.ebooklibonline.com>

Hello dear friend!

Thank you very much for reading.

Enter the link into your browser.

The full manual is available for immediate download.

<https://www.ebooklibonline.com>