

SERVICE MANUAL

L213 / L215 / L218 / L220

L223 / L225 / L230

200 Series Skid Steer Loader

C227 / C232 / C238

200 Series Compact Track Loader

Part number 84522361

1st edition English

June 2011





SERVICE MANUAL

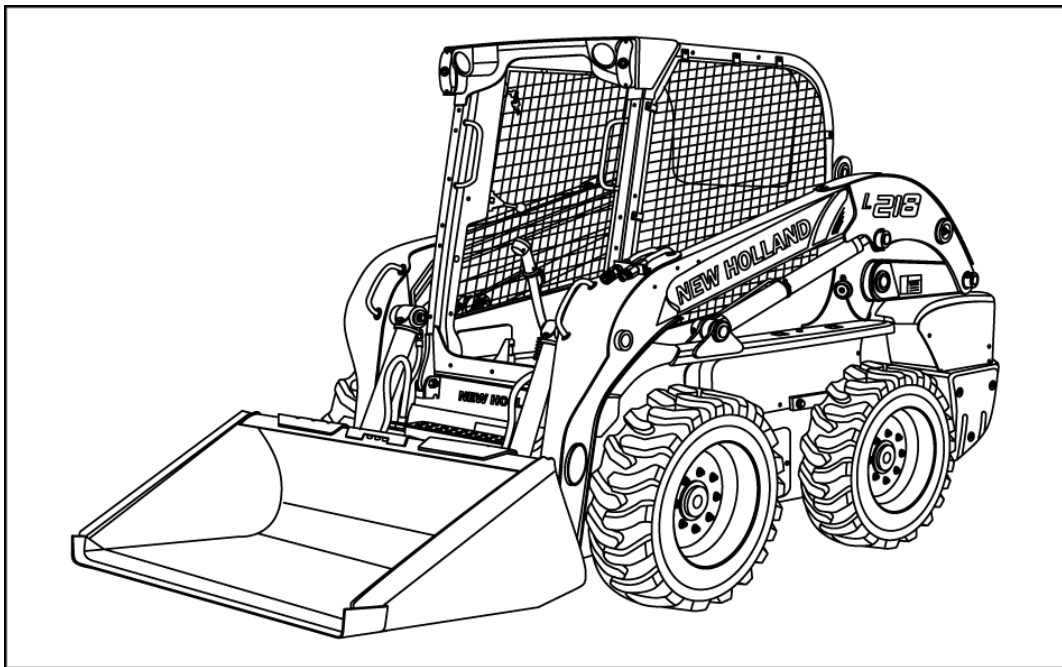

C227 , C232 , C238 , L213 , L215 , L218 , L220 , L223 , L225 , L230

Contents

INTRODUCTION

HYDRAULIC, PNEUMATIC, ELECTRICAL, ELECTRONIC SYSTEMS A

PRIMARY HYDRAULIC POWER SYSTEM.....	A.10.A
SECONDARY HYDRAULIC POWER SYSTEM.....	A.12.A
HYDRAULIC COMMAND SYSTEM.....	A.14.A
HIGH-FLOW HYDRAULIC POWER SYSTEM.....	A.16.A
ELECTRICAL POWER SYSTEM	A.30.A
LIGHTING SYSTEM.....	A.40.A
ELECTRONIC SYSTEM	A.50.A
FAULT CODES.....	A.50.A

ENGINE AND PTO IN B

ENGINE	B.10.A
FUEL AND INJECTION SYSTEM.....	B.20.A
AIR INTAKE SYSTEM.....	B.30.A
ENGINE COOLANT SYSTEM	B.50.A
STARTING SYSTEM	B.80.A

TRANSMISSION, DRIVE AND PTO OUT C

TRANSMISSION Hydrostatic.....	C.20.F
-------------------------------	--------

AXLES, BRAKES AND STEERING..... D

Final drive	D.15.A
Final drive Hydraulic drive	D.15.C
STEERING Mechanical	D.20.B
PARKING BRAKE Hydraulic	D.32.C
WHEELS AND TRACKS Tracks	D.50.B
WHEELS AND TRACKS Wheels.....	D.50.C

FRAME AND CAB E

FRAME Primary frame	E.10.B
SHIELD.....	E.20.A

<https://www.ebooklibonline.com>

Hello dear friend!

Thank you very much for reading.

Enter the link into your browser.

The full manual is available for immediate download.

<https://www.ebooklibonline.com>

USER CONTROLS AND SEAT	E.32.A
USER CONTROLS AND SEAT Operator seat	E.32.C
USER PLATFORM	E.34.A
ENVIRONMENT CONTROL Air-conditioning system	E.40.C
SAFETY SECURITY ACCESSORIES Safety	E.50.B
FRAME POSITIONING	F
STABILISING Ballasting	F.20.B
TOOL POSITIONING	G
LIFTING	G.10.A
TILTING	G.20.A
LEVELLING	G.30.A
SECONDARY FUNCTIONS Hydraulic	G.90.C
HITCH AND WORKING TOOL	H
BOOM Lift	H.20.B
ARM TOOL ATTACHMENT Tilt	H.30.C
SINGLE ARM Lift	H.40.B
SINGLE ARM TOOL ATTACHMENT Tilt	H.50.C
EXCAVATING AND LANDSCAPING	J
DIGGING Non-articulated digging tools	J.20.B
CARRYING Unarticulated tools	J.50.B
COUPLING Mechanical coupling	J.80.B
COUPLING Hydraulic coupling	J.80.C



INTRODUCTION

Contents

INTRODUCTION

Foreword - Ecology and the environment	3
Safety rules	4
2 - Series	
Safety rules - Personal Safety	5
Safety rules	6
Basic instructions - Important notice regarding equipment servicing	7
Torque - Minimum tightening torques for normal assembly	8
2 - Series	
General specification - General Welding	13

Foreword - Ecology and the environment

Soil, air, and water are vital factors of agriculture and life in general. When legislation does not yet rule the treatment of some of the substances which are required by advanced technology, sound judgement should govern the use and disposal of products of a chemical and petrochemical nature.

NOTICE: *The following are recommendations which may be of assistance:*

- Become acquainted with and ensure that you understand the relative legislation applicable to your country.
- Where no legislation exists, obtain information from suppliers of oils, filters, batteries, fuels, antifreeze, cleaning agents, etc., with regard to their effect on man and nature and how to safely store, use and dispose of these substances.
- Agricultural consultants will, in many cases, be able to help you as well.

HELPFUL HINTS

- Avoid filling tanks using cans or inappropriate pressurized fuel delivery systems which may cause considerable spillage.
- In general, avoid skin contact with all fuels, oils, acids, solvents, etc. Most of them contain substances which may be harmful to your health.
- Modern oils contain additives. Do not burn contaminated fuels and or waste oils in ordinary heating systems.
- Avoid spillage when draining off used engine coolant mixtures, engine, gearbox and hydraulic oils, brake fluids, etc. Do not mix drained brake fluids or fuels with lubricants. Store them safely until they can be disposed of in a proper way to comply with local legislation and available resources.
- Modern coolant mixtures, i.e. antifreeze and other additives, should be replaced every two years. They should not be allowed to get into the soil but should be collected and disposed of properly.
- Do not open the air-conditioning system yourself. It contains gases which should not be released into the atmosphere. Your NEW HOLLAND CONSTRUCTION dealer or air conditioning specialist has a special extractor for this purpose and will have to recharge the system properly.
- Repair any leaks or defects in the engine cooling or hydraulic system immediately.
- Do not increase the pressure in a pressurized circuit as this may lead to a component failure.
- Protect hoses during welding as penetrating weld splatter may burn a hole or weaken them, allowing the loss of oils, coolant, etc.

Safety rules

2 - Series

Personal safety





This is the safety alert symbol. It is used to alert you to potential personal injury hazards. Obey all safety messages that follow this symbol to avoid possible death or injury.

Throughout this manual and on machine decals, you will find the signal words DANGER, WARNING, and CAUTION followed by special instructions. These precautions are intended for the personal safety of you and those working with you.

Read and understand all the safety messages in this manual before you operate or service the machine.

 DANGER indicates a hazardous situation which, if not avoided, will result in death or serious injury. The color associated with DANGER is RED.

 WARNING indicates a hazardous situation which, if not avoided, could result in death or serious injury. The color associated with WARNING is ORANGE.

 CAUTION, used with the safety alert symbol, indicates a hazardous situation which, if not avoided, could result in minor or moderate injury. The color associated with CAUTION is YELLOW.

FAILURE TO FOLLOW DANGER, WARNING, AND CAUTION MESSAGES COULD RESULT IN DEATH OR SERIOUS INJURY.

Machine safety

NOTICE: Notice indicates a situation which, if not avoided, could result in machine or property damage. The color associated with Notice is BLUE.

Throughout this manual you will find the signal word Notice followed by special instructions to prevent machine or property damage. The word Notice is used to address practices not related to personal safety.

Information

NOTE: Note indicates additional information which clarifies steps, procedures, or other information in this manual.

Throughout this manual you will find the word Note followed by additional information about a step, procedure, or other information in the manual. The word Note is not intended to address personal safety or property damage.

Safety rules - Personal Safety

Carefully study these precautions, and those included in the external attachment operators manual, and insist that they be followed by those working with and for you.

1. Thoroughly read and understand this manual and the attachment operators manual before operating this or any other equipment.
2. Be sure everyone is clear of the machine before starting. Blow the horn, if equipped, three times before starting engine.
3. Only the operator should be on the machine when in operation. Never allow anyone to climb on to the machine while it is in motion. If the machine is equipped with an Instructors Seat, this must only be used for training purposes. Passengers must not be allowed to use the Instructors Seat.
4. Keep all shields in place. Never work around the machine or any of the attachments while wearing loose clothing that might catch on moving parts.
5. Observe the following precautions whenever lubricating the machine or making adjustments.
 - Disengage all clutching levers or switches.
 - Lower the attachment, if equipped, to the ground or raise the attachment completely and engage the cylinder safety locks . Completing these actions will prevent the attachment from lowering unexpectedly.
 - Engage the parking brake.
 - Shut off the engine and remove the key.
6. Always keep the machine in gear while going downhill.
7. The machine should always be equipped with sufficient front or rear axle weight for safe operation.
8. Under some field conditions, more weight may be required at the front or rear axle for adequate stability. This is especially important when operating in hilly conditions or/when using heavy attachments.
9. Always lower the attachment, shut off the engine, set the parking brake, engage the transmission gears and remove the key before leaving the operators platform.
10. If the attachment or machine should become obstructed or plugged; set the parking brake, shut off the engine and remove the key, engage the transmission gears, wait for all machine or attachment motion to come to a stop, before leaving the operators platform to removing the obstruction or plug.
11. Never disconnect or make any adjustments to the hydraulic system unless the machine and/or the attachment is lowered to the ground or the safety lock(s) is in the engaged position.
12. Use of the flashing lights is highly recommended when operating on a public road.
13. When transporting on a road or highway, use accessory lights and devices for adequate warning to the operators of other vehicles. In this regard, check local government regulations. Various safety lights and devices are available from your NEW HOLLAND CONSTRUCTION dealer.
14. Practice safety 365 days a year.
15. Keep all your equipment in safe operating condition.
16. Keep all guards and safety devices in place.
17. Always set the parking brake, shut off the engine and remove the key, engage the transmission gears, wait for all machine or attachment motion to come to a stop, before leaving the operators platform to service the machine and attachment.
18. Remember: A careful operator is the best insurance against an accident.
19. Extreme care should be taken in keeping hands and clothing away from moving parts.



SERVICE MANUAL

HYDRAULIC, PNEUMATIC, ELECTRICAL, ELECTRONIC SYSTEMS

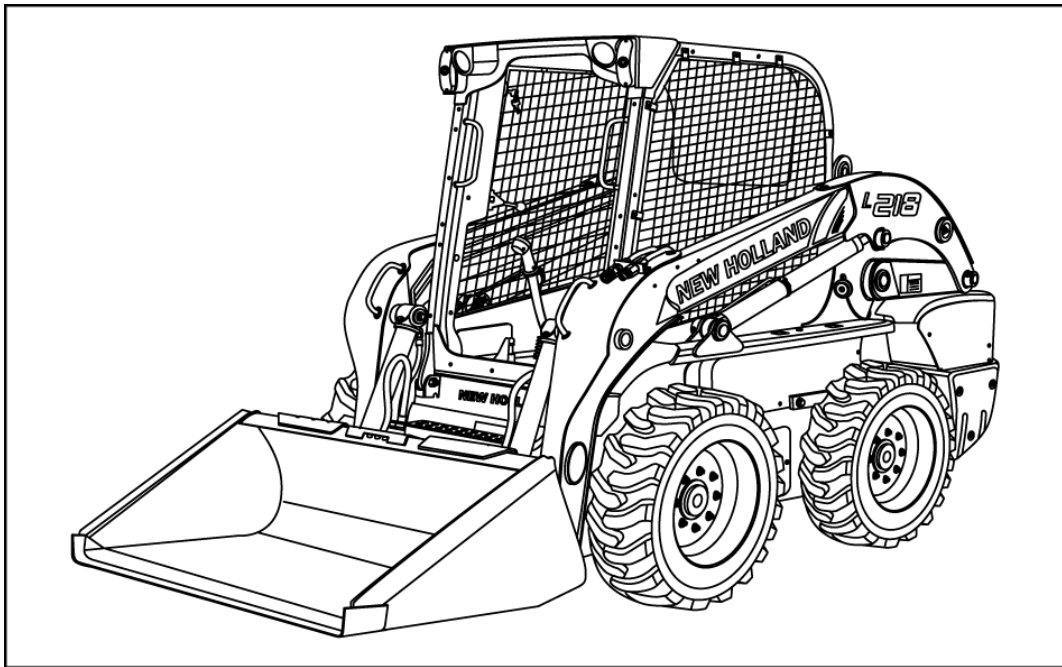

C227 , C232 , C238 , L213 , L215 , L218 , L220 , L223 , L225 , L230

Hydraulic pump - Flow test Loader hydraulic pump

NOTE: Two persons are required to perform the flowmeter tests for safety to avoid possible injury. One person must be seated in the operators seat when the engine is running. The second person is to control the flowmeter and take the readings.

1. Park the machine on a level surface. Lower the loader bucket to the floor. Stop the engine.
2. Disconnect the hose from the loader pump pressure port (1) at Test Point 1. Install a plug in the hose. Connect the flowmeter inlet hose to the fitting at the pressure port (1) of the pump. If equipped with high flow, disconnect the hose from the high flow pressure port (2). Install a plug in the hose. Connect a second flowmeter inlet hose to the fitting at the pressure port (2) of the pump.

NOTE: The first picture is for models equipped with a hydraulic gear pump only. The second picture is for models equipped with a hydraulic gear pump with high flow option.

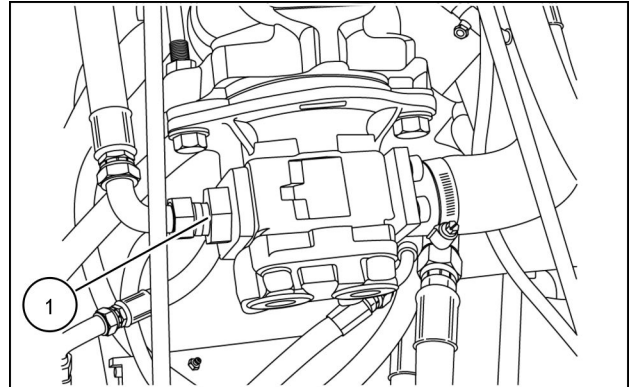

931002073 1

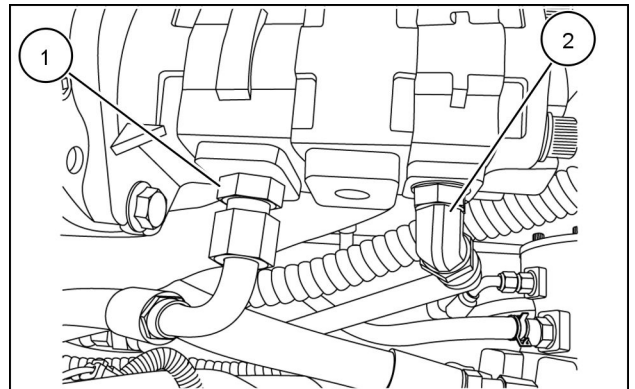

931001956 2

3. Put the flowmeter outlet hose into the hydraulic reservoir. Use wire to fasten the flowmeter outlet hose below the surface of the hydraulic oil.
4. Make sure that the oil level in the hydraulic reservoir is correct.
5. Make sure that the pressure valve of the flowmeter is opened completely.
6. The oil must be at operating temperature. If the oil is not at operating temperature, run the engine at full throttle and close the pressure valve of the flowmeter until the pressure gauge indicates 103 bar (1500 psi). Continue to run the engine at full throttle until the temperature of the oil is 52°C (125°F). Then open the pressure valve completely.
7. Make sure that the pressure valves are opened completely. Adjust the engine speed to 2300 r/min (rpm) and read the flow gauge. Read the flow and record the reading as test number 1 .
8. Slowly close the pressure valve on the flowmeter on the loader pump until the pressure gauge indicates 97 bar (1400 psi). Keep the engine running at 2300 r/min (rpm). Read the flow and record the reading as test number 2 .

9. Slowly close the pressure valve on the flowmeter until the pressure gauge indicates 124 bar (1800 psi). Keep the engine running at 2300 r/min (rpm). Read the flow and record the reading as test number 3.
10. Slowly close the pressure valve on the flowmeter until the pressure gauge indicates 152 bar (2200 psi). Keep the engine running at 2300 r/min (rpm). Read the flow and record the reading as test number 4.
11. Open the pressure valve completely. If the high flow pump is installed, repeat steps 8 thru 10 on the high flow section. Then decrease the engine speed to low idle and stop the engine.

NOTE: *Understanding the results of the tests are outlined in the steps below.*

12. If the output at minimum pressure was less than the specification for Gear Pump Flow to Loader (Machine in Neutral) refer to **PRIMARY HYDRAULIC POWER SYSTEM - General specification (A.10.A)**, the problem can be a restriction between the reservoir and the gear pump, or the problem can be a badly worn or damaged gear pump.
13. If the output at minimum pressure was more than the specification refer to **PRIMARY HYDRAULIC POWER SYSTEM - General specification (A.10.A)**, there are no problems between the reservoir and the gear pump. However, the gear pump can be worn or damaged and still have good flow at minimum pressure.
14. Loss of output at 152 bar (2200 psi) indicates that the gear pump is worn or damaged. To determine the efficiency of the gear pump, divide the flow indication from test number 4 by the flow indication from test number 1. This answer multiplied by 100 is the percent efficiency of the gear pump. If the efficiency of the gear pump is less than 70%, repair or replace the gear pump. If the efficiency of the gear pump is more than 70%, the pump is good.

Hydraulic pump - Install

NOTE: Before pump installation, apply Molykote G-4700 (P/N 86983138) to the pump and the coupling splines. Pre-fill the pump with clean hydraulic oil. Inspect O-ring on the pump pilot and replace if necessary. Lubricate the O-ring with clean hydraulic oil.

1. Hold the pump in the mounting location. Rotate the gear pump shaft until it aligns with the coupling (1) splines at the rear of the hydrostatic pump. Shown with call out (X) After the splines are aligned, move the pump inward until the mounting flange is flush with the mounting surface of the hydrostatic pump.

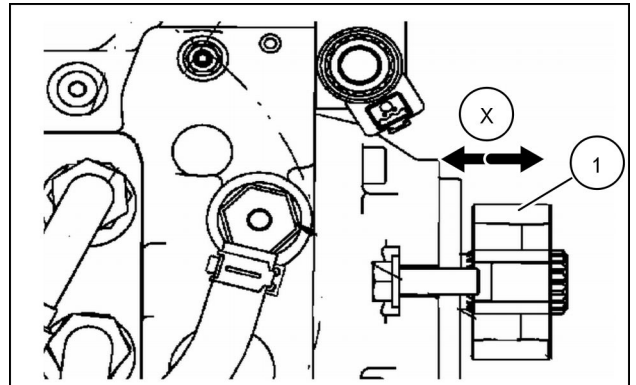

93111555A 1

2. Apply Loctite 243 to the pump mounting bolts (4). Install washers on the bolts and install the bolts into the pump mounting flange. Tighten the mounting bolts.

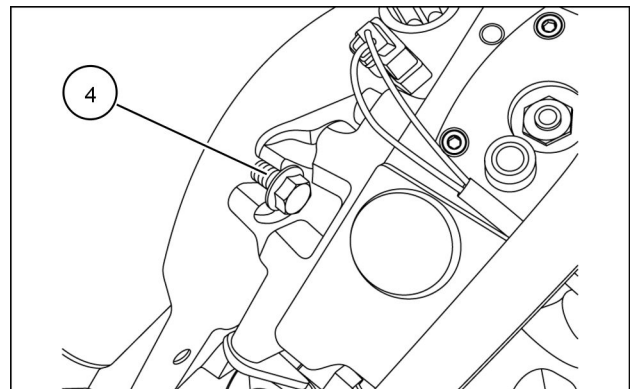

931001928 2

3. Connect gear pump hydraulic hoses (A) and (B), as shown.

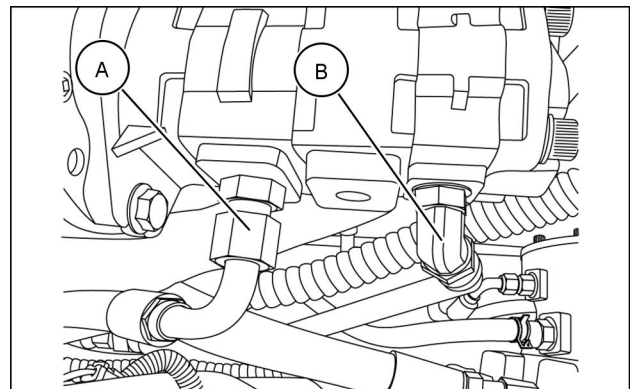

931001956 3

4. Connect the gear pump supply hose (1) and tighten hose clamp.

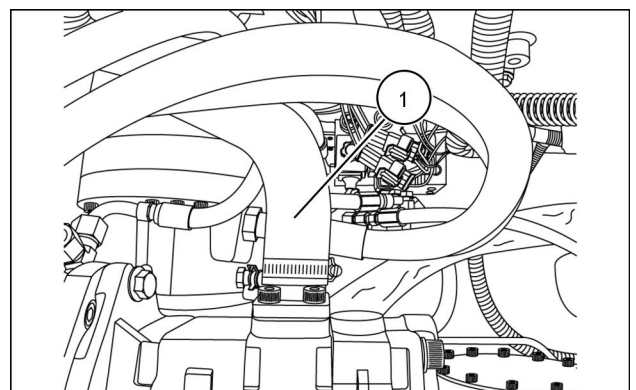

931001955 4

5. Connect case drain hose **(2)** and secure with clamp.

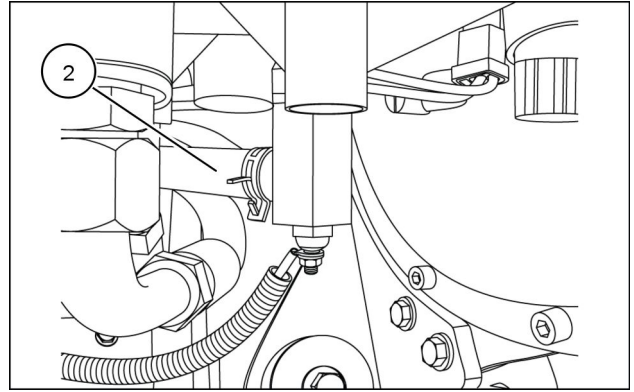

931001963 5

6. Connect hydraulic hose **(3)**, as shown.

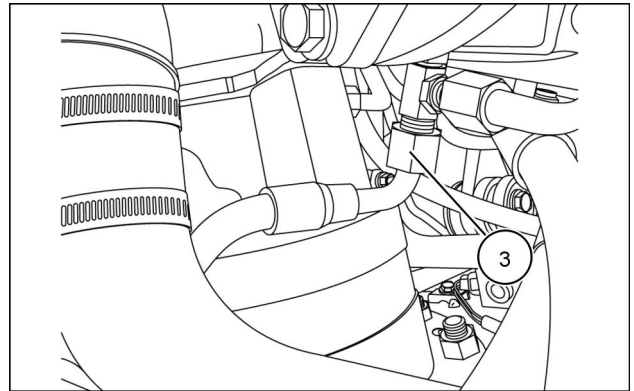

931001972 6

7. Connect left hand side drive motor hoses **(C)** and **(D)**.

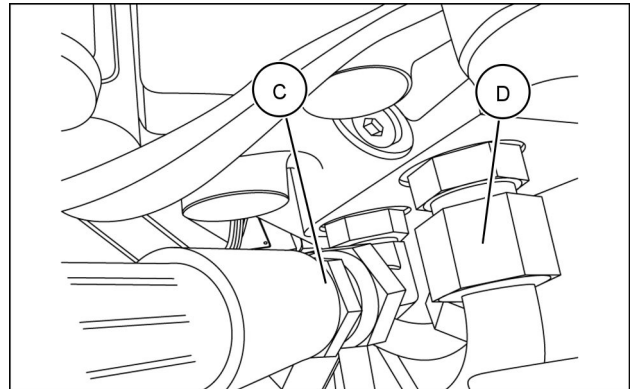

931001971 7

8. Connect right hand side motor hoses **(5)** and **(6)**.

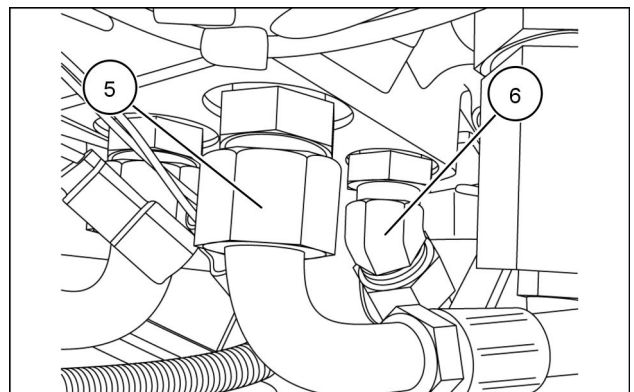

931001970 8

9. Connect the top hydraulic hose (7).

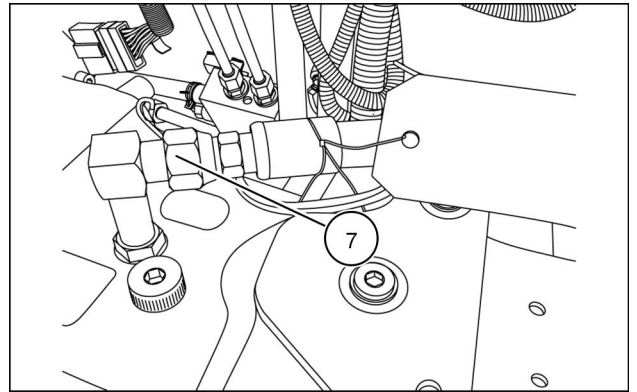

931001966 9

10. Connect the oil supply hose (8) and tighten hose clamp.

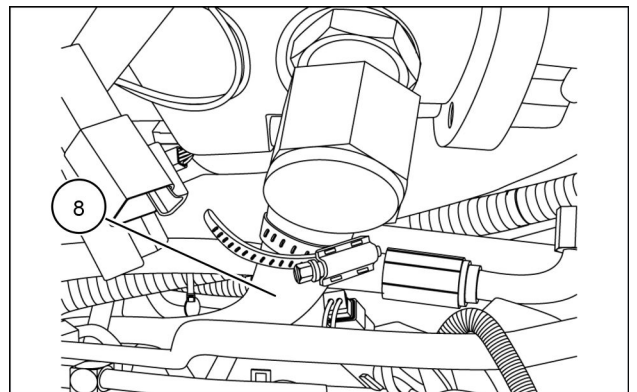

931001965 10

11. Connect right hand side hydraulic tube (9).

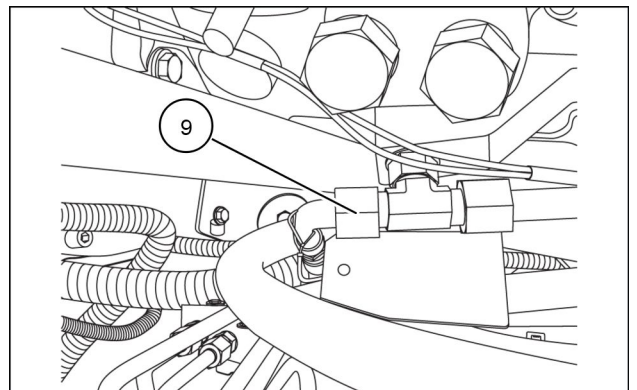

931001964 11

12. Connect charge pressure switch (10) and secure with nut.

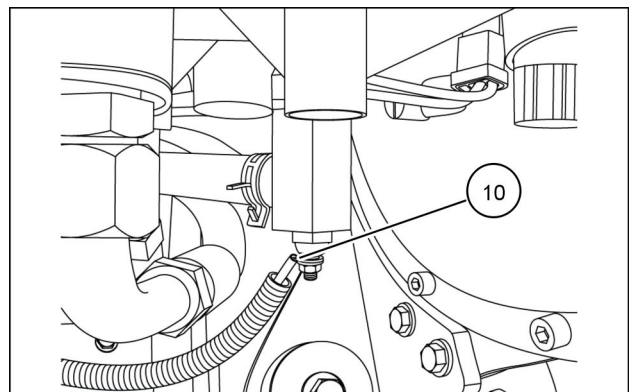

931001963 12

13. Connect the right hand side back up alarm connections **(11)**.

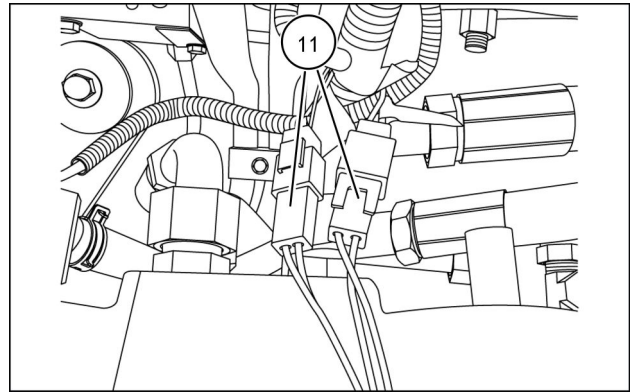

931001962 13

14. Connect the left hand side back up alarm connections **(12)**.

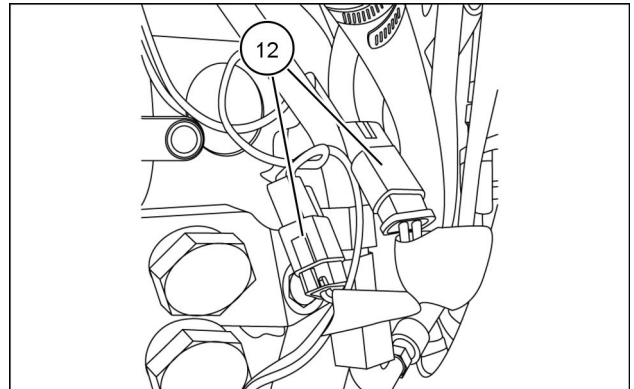

931002115 14

15. Connect the control wires **(E)** and **(F)** located on the bottom of pumps.

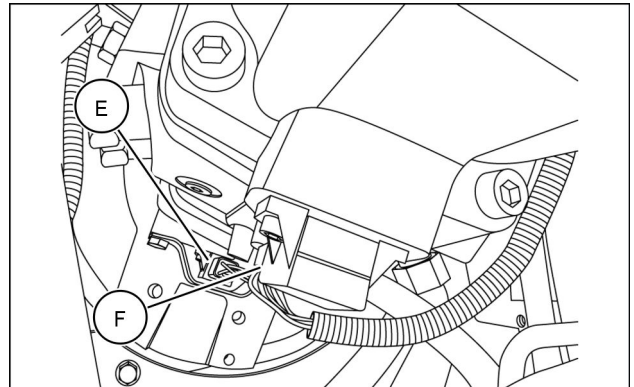

931001961 15



Suggest:

If the above button click is invalid.

Please download this document

first, and then click the above link

to download the complete manual.

Thank you so much for reading

Charge pump - Pressure test

Testing the low-pressure charge system is safer and usually more informative than going into the high-pressure test ports. To obtain as much system information as possible, charge pressure readings must be taken in neutral as well as working the system in both the forward and reverse directions.

With the system in neutral, only charge pressure is present in the closed loop. At this time, the leakage from the system is the least and the charge pressure is the highest. As the system is pressurized, the leakage from the system will increase and the charge pump flow will make up for this leakage. With more of the charge pump oil flowing to the closed loop, less oil will flow across the charge pressure relief valve, and therefore the pressure will be slightly less. If the leakage from the system is excessive, the charge pressure will drop off more. This slight drop in charge pressure between the system in neutral and with the system under load indicates the condition of the closed loop system components.

1. Raise and securely block the unit off the ground.
2. Remove the brake release lines from the tee fitting that connects to the B port (1) of the brake valve (2) and cap lines.

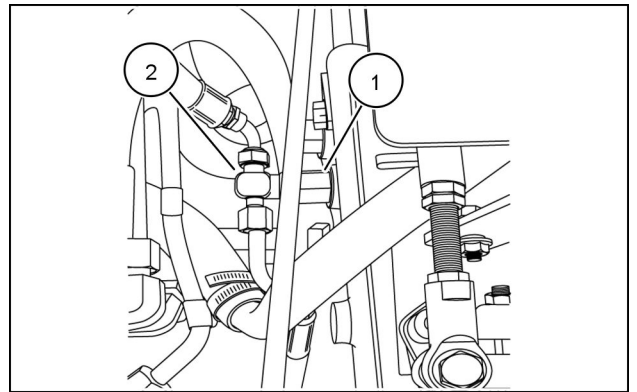

931002074 1

3. Cap the tee fitting that connects to the B port of the brake valve.
4. Connect a 4,137 kPa (41 bar) (600 psi) pressure gauge to the charge pressure test port. Remove the hose from the tee fitting and install a 4,137 kPa(600 psi) pressure gauge.
5. If the hydraulic oil is not at operating temperature, run the engine at full throttle and hold the bucket control lever in the ROLLBACK position for 30 seconds. Then return the bucket control lever to NEUTRAL for 15 seconds. Repeat this cycle until the temperature of the oil is at least 52°C (125°F).
6. Continue to run the engine at full throttle. Read the pressure gauge and record the Charge Pressure reading. Stop the engine.
7. The pressure reading must be 25 - 28 bar (362 - 410 psi) or the relief valve must be adjusted with shims.
8. If the pressure is correct, go to step 10. If the pressure is not correct, loosen the cap on the hydraulic reservoir. Remove the plug, shim(s), spring, and poppet for the charge pressure relief valve.
9. Inspect the parts of the charge relief valve. If the parts are good, add shim(s) from the shim kit, refer to parts manual, and repeat steps 5 through 9 until the pressure is correct.

NOTICE: For the following test the machine **MUST** be raised up on supports until the tires are above the floor. This is a safety procedure if the hydraulic parking brakes fail to hold.

<https://www.ebooklibonline.com>

Hello dear friend!

Thank you very much for reading.

Enter the link into your browser.

The full manual is available for immediate download.

<https://www.ebooklibonline.com>