

SERVICE MANUAL

L221 / L228

Tier 4B (final)

200 Series Skid Steer Loader

L221 PIN NEM479941 and above; L228 PIN NFM401546 and above

C227 / C232

Tier 4B (final)

200 Series Compact Track Loader

C227 PIN NDM471836 and above; C232 PIN NFM402195 and above

Part number 47851950

English

May 2015

Replaces part number 47712047



Link Product / Engine

Product	Market Product	Engine
C227 TIER 4B Final [NDM471836 -]	North America	F5HFL463A*F001
C227 TIER 4B Final [NDM471836 -]	Europe	F5HFL463A*F001
C232 TIER 4B (FINAL)	North America	F5HFL463A*F001
C232 TIER 4B (FINAL)	Europe	F5HFL463A*F001
L221 TIER 4B Final [NEM479941 -]	North America	F5HFL463A*F001
L221 TIER 4B Final [NEM479941 -]	Europe	F5HFL463A*F001
L228 TIER 4B (FINAL)	Europe	F5HFL463A*F001
L228 TIER 4B (FINAL)	North America	F5HFL463A*F001

Contents

INTRODUCTION

Engine.....	10
[10.001] Engine and crankcase	10.1
[10.216] Fuel tanks	10.2
[10.501] Exhaust Gas Recirculation (EGR) - Diesel Particulate Filter (DPF) exhaust treatment	10.3
[10.400] Engine cooling system	10.4
[10.414] Fan and drive	10.5
[10.304] Engine lubrication system.....	10.6
Power coupling.....	19
[19.121] Pump-drive assembly	19.1
Front axle system	25
[25.450] Chain drive system.....	25.1
Rear axle system.....	27
[27.650] Chain drive system.....	27.1
Hydrostatic drive	29
[29.200] Mechanical control	29.1
[29.218] Pump and motor components.....	29.2
[29.202] Hydrostatic transmission	29.3
[29.134] Two-speed assembly.....	29.4
Brakes and controls	33
[33.110] Parking brake or parking lock	33.1
Hydraulic systems.....	35
[35.000] Hydraulic systems.....	35.1
[35.300] Reservoir, cooler, and filters.....	35.2
[35.104] Fixed displacement pump.....	35.3

<https://www.ebooklibonline.com>

Hello dear friend!

Thank you very much for reading.

Enter the link into your browser.

The full manual is available for immediate download.

<https://www.ebooklibonline.com>

[35.359] Main control valve	35.4
[35.525] Auxiliary hydraulic valves and lines	35.5
[35.600] High flow hydraulics	35.6
[35.724] Front loader hydraulic system control	35.7
[35.701] Front loader arm hydraulic system	35.8
[35.734] Tool quick coupler hydraulic system	35.9
Frames and ballasting	39
[39.140] Ballasts and supports	39.1
Wheels	44
[44.511] Front wheels	44.1
[44.520] Rear wheels	44.2
Tracks and track suspension	48
[48.130] Track frame and driving wheels	48.1
[48.100] Tracks	48.2
[48.134] Track tension units	48.3
[48.138] Track rollers	48.4
Cab climate control	50
[50.100] Heating	50.1
[50.200] Air conditioning	50.2
Electrical systems	55
[55.000] Electrical system	55.1
[55.010] Fuel injection system	55.2
[55.011] Fuel tank system	55.3
[55.012] Engine cooling system	55.4
[55.019] Hydrostatic drive control system	55.5
[55.036] Hydraulic system control	55.6
[55.051] Cab Heating, Ventilation, and Air-Conditioning (HVAC) controls	55.7
[55.100] Harnesses and connectors	55.8

[55.202] Cold start aid	55.9
[55.302] Battery.....	55.10
[55.408] Warning indicators, alarms, and instruments	55.11
[55.512] Cab controls.....	55.12
[55.518] Wiper and washer system.....	55.13
[55.640] Electronic modules	55.14
[55.DTC] FAULT CODES.....	55.15
Front loader and bucket.....	82
[82.100] Arm.....	82.1
[82.300] Bucket.....	82.2
Platform, cab, bodywork, and decals	90
[90.150] Cab.....	90.1
[90.154] Cab doors and hatches	90.2



INTRODUCTION

Foreword - Important notice regarding equipment servicing

C227	
C232	
L221	
L228	

All repair and maintenance work listed in this manual must be carried out only by qualified dealership personnel, strictly complying with the instructions given, and using, whenever possible, the special tools.

Anyone who performs repair and maintenance operations without complying with the procedures provided herein shall be responsible for any subsequent damages.

The manufacturer and all the organizations of its distribution chain, including - without limitation - national, regional, or local dealers, reject any responsibility for damages caused by parts and/or components not approved by the manufacturer, including those used for the servicing or repair of the product manufactured or marketed by the manufacturer. In any case, no warranty is given or attributed on the product manufactured or marketed by the manufacturer in case of damages caused by parts and/or components not approved by the manufacturer.

The manufacturer reserves the right to make improvements in design and changes in specifications at any time without notice and without incurring any obligation to install them on units previously sold. Specifications, descriptions, and illustrative material herein are as accurate as known at time of publication but are subject to change without notice.

In case of questions, refer to your NEW HOLLAND CONSTRUCTION Sales and Service Networks.

Safety rules - Ecology and the environment

C227	
C232	
L221	
L228	

Soil, air, and water quality is important for all industries and life in general. When legislation does not yet rule the treatment of some of the substances that advanced technology requires, sound judgment should govern the use and disposal of products of a chemical and petrochemical nature.

Familiarize yourself with the relative legislation applicable to your country, and make sure that you understand this legislation. Where no legislation exists, obtain information from suppliers of oils, filters, batteries, fuels, anti-freeze, cleaning agents, etc., with regard to the effect of these substances on man and nature and how to safely store, use, and dispose of these substances.

Helpful hints

- Avoid the use of cans or other inappropriate pressurized fuel delivery systems to fill tanks. Such delivery systems may cause considerable spillage.
- In general, avoid skin contact with all fuels, oils, acids, solvents, etc. Most of these products contain substances that may be harmful to your health.
- Modern oils contain additives. Do not burn contaminated fuels and or waste oils in ordinary heating systems.
- Avoid spillage when you drain fluids such as used engine coolant mixtures, engine oil, hydraulic fluid, brake fluid, etc. Do not mix drained brake fluids or fuels with lubricants. Store all drained fluids safely until you can dispose of the fluids in a proper way that complies with all local legislation and available resources.
- Do not allow coolant mixtures to get into the soil. Collect and dispose of coolant mixtures properly.
- The air-conditioning system contains gases that should not be released into the atmosphere. Consult an air-conditioning specialist or use a special extractor to recharge the system properly.
- Repair any leaks or defects in the engine cooling system or hydraulic system immediately.
- Do not increase the pressure in a pressurized circuit as this may lead to a component failure.
- Protect hoses during welding. Penetrating weld splatter may burn a hole or weaken hoses, allowing the loss of oils, coolant, etc.

Battery recycling

Batteries and electric accumulators contain several substances that can have a harmful effect on the environment if the batteries are not properly recycled after use. Improper disposal of batteries can contaminate the soil, groundwater, and waterways. NEW HOLLAND CONSTRUCTION strongly recommends that you return all used batteries to a NEW HOLLAND CONSTRUCTION dealer, who will dispose of the used batteries or recycle the used batteries properly. In some countries, this is a legal requirement.



Mandatory battery recycling

NOTE: The following requirements are mandatory in Brazil.

Batteries are made of lead plates and a sulfuric acid solution. Because batteries contain heavy metals such as lead, CONAMA Resolution 401/2008 requires you to return all used batteries to the battery dealer when you replace any batteries. Do not dispose of batteries in your household garbage.

Points of sale are obliged to:

- Accept the return of your used batteries
- Store the returned batteries in a suitable location
- Send the returned batteries to the battery manufacturer for recycling

Safety rules

C227	
C232	
L221	
L228	

Personal safety





This is the safety alert symbol. It is used to alert you to potential personal injury hazards. Obey all safety messages that follow this symbol to avoid possible death or injury.

Throughout this manual you will find the signal words DANGER, WARNING, and CAUTION followed by special instructions. These precautions are intended for the personal safety of you and those working with you.

Read and understand all the safety messages in this manual before you operate or service the machine.

 DANGER indicates a hazardous situation that, if not avoided, will result in death or serious injury.

 WARNING indicates a hazardous situation that, if not avoided, could result in death or serious injury.

 CAUTION indicates a hazardous situation that, if not avoided, could result in minor or moderate injury.

FAILURE TO FOLLOW DANGER, WARNING, AND CAUTION MESSAGES COULD RESULT IN DEATH OR SERIOUS INJURY.

Machine safety

NOTICE: Notice indicates a situation that, if not avoided, could result in machine or property damage.

Throughout this manual you will find the signal word Notice followed by special instructions to prevent machine or property damage. The word Notice is used to address practices not related to personal safety.

Information

NOTE: Note indicates additional information that clarifies steps, procedures, or other information in this manual.

Throughout this manual you will find the word Note followed by additional information about a step, procedure, or other information in the manual. The word Note is not intended to address personal safety or property damage.



SERVICE MANUAL

Engine

C227 TIER 4B Final [NDM471836 -]

C232 TIER 4B (FINAL)

L221 TIER 4B Final [NEM479941 -]

L228 TIER 4B (FINAL)

Engine - Drain fluid

C227 TIER 4B Final [NDM471836 -]	
C232	
L221 TIER 4B Final [NEM479941 -]	
L228	

1. Remove the access cover at the rear, lower left of the machine, exposing the engine oil drain hose and remote oil filter.
2. Remove the drain plug to drain the oil.
3. When the oil has completely drained, reinstall the drain plug and torque to **68 - 82 N·m (50 - 61 lb ft)**.

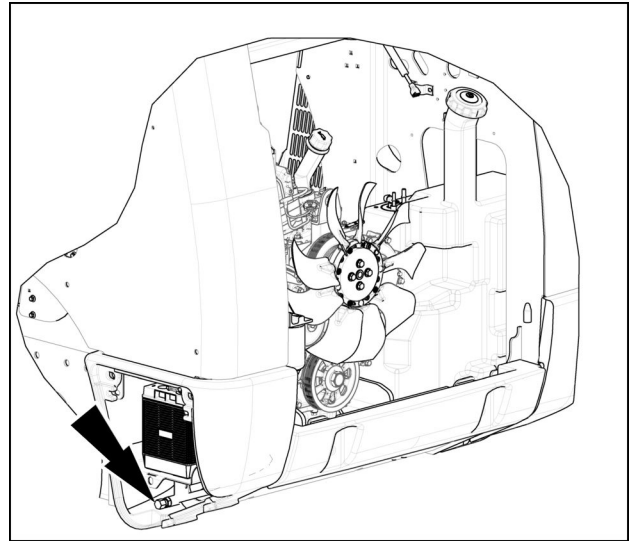

63109370 1

Engine - Remove

C227 TIER 4B Final [NDM471836 -]	
C232	
L221 TIER 4B Final [NEM479941 -]	
L228	

▲ WARNING

Heavy objects!

Lift and handle all heavy components using lifting equipment with adequate capacity. Always support units or parts with suitable slings or hooks. Make sure the work area is clear of all bystanders. Failure to comply could result in death or serious injury.

W0398A

The following procedure has been performed on a radial lift machine. Engine removal for vertical lift machines is very similar.

Prior operation:

Tilt the cab. Please see **Cab tilting system - Tilt (90.150)**.

Prior operation:

Disconnect the battery. See **Battery - Disconnect (55.302)**.

Prior operation:

Drain the engine oil. Please see **Engine - Drain fluid (10.001)**.

Prior operation:

Drain the coolant. Please see **Radiator - Drain fluid (10.400)**.

Prior operation:

Discharge the A/C system (if equipped). See **Air conditioning - Discharging (50.200)**.

1. Remove access plate (1) for the engine oil pan from the chassis.

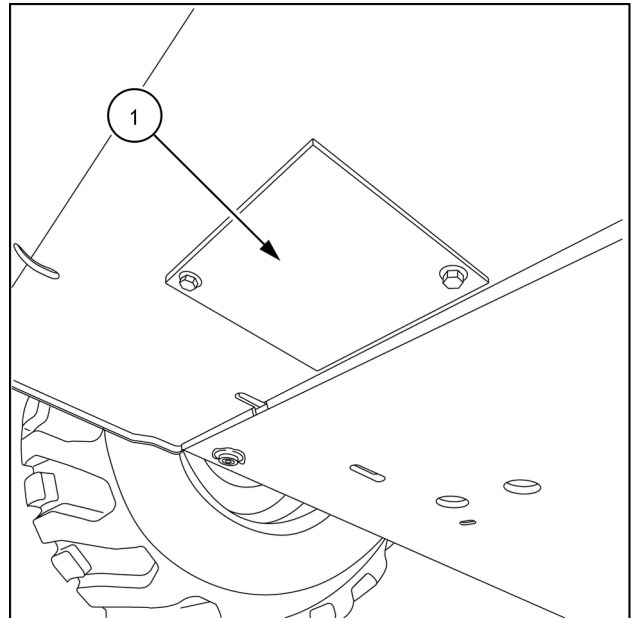

RAPH12SSL0233AA 1

2. Disconnect the hose (1) for the oil drain plug from the engine oil pan.

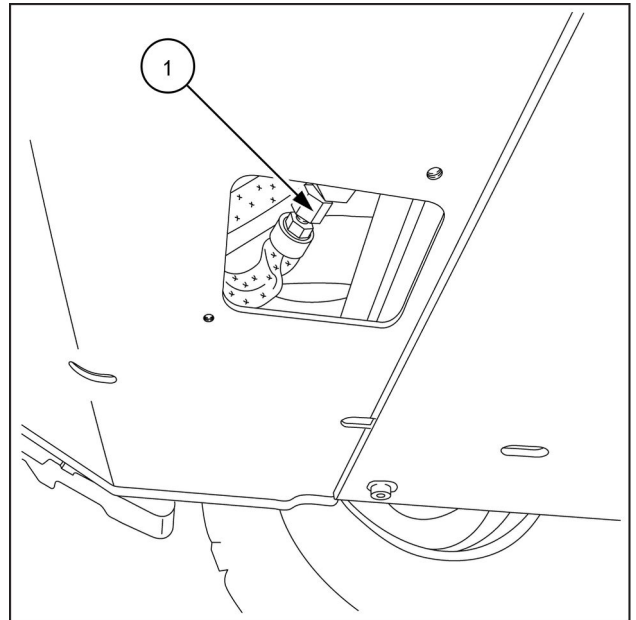

RAPH12SSL0232AA 2

3. Remove the mounting bolts for the overflow bottle.
4. Remove the overflow bottle from the chassis.

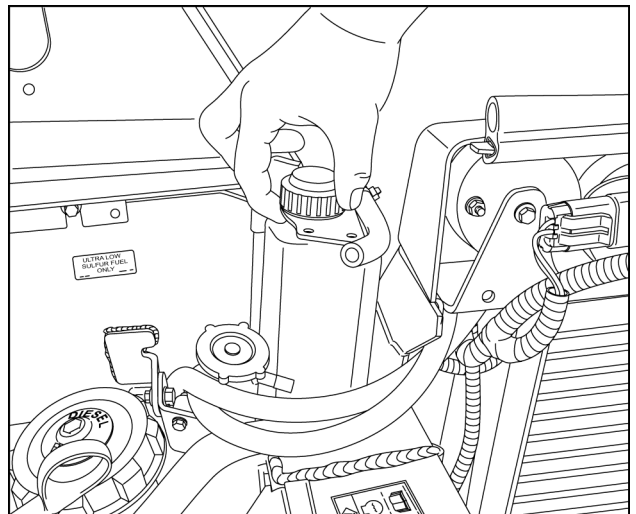

RAIL14SSL0845BA 3

5. If equipped with A/C, disconnect the A/C lines (1) from the condenser.
6. Disconnect the fan motor (2) from the wiring harness.

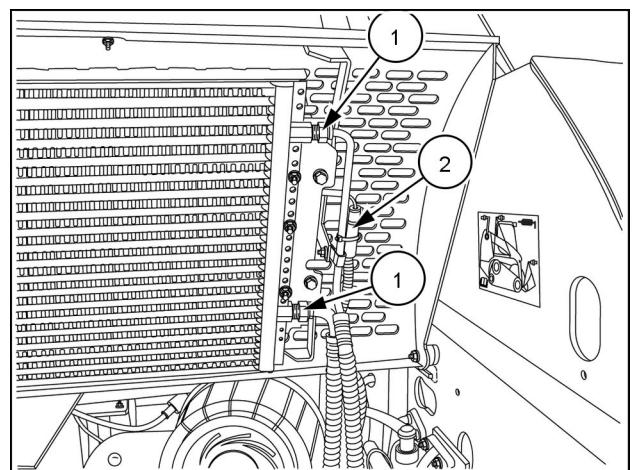

RAPH12SSL0075AA 4

7. Support the engine hood with a suitable lifting device.
8. Disconnect the engine hood strut (1) from the engine hood.

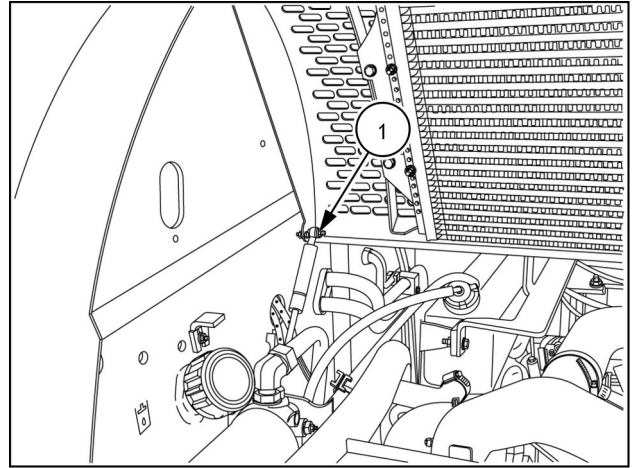

RAPH12SSL0074AA 5

9. Remove the mounting hardware (2) from the engine hood.
10. Remove the engine hood (1) from the chassis.

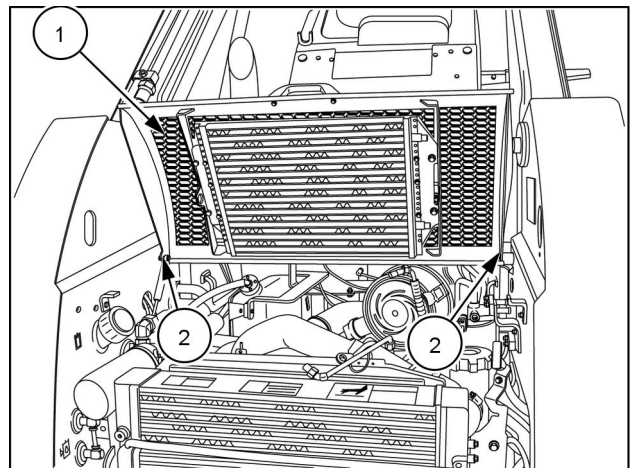

RAPH12SSL0073AA 6

11. Remove the engine cover (1) from the chassis.

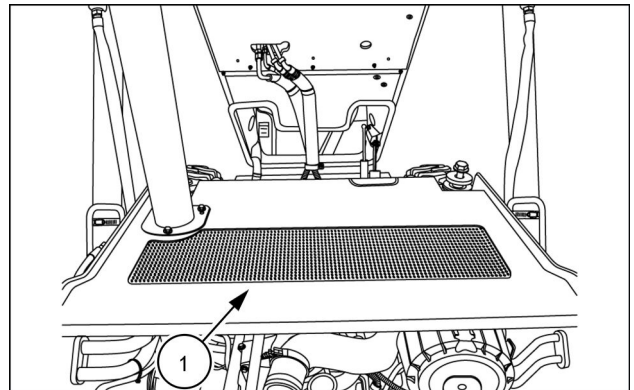

931001899 7

12. Remove the air cooler (1) from the shroud.

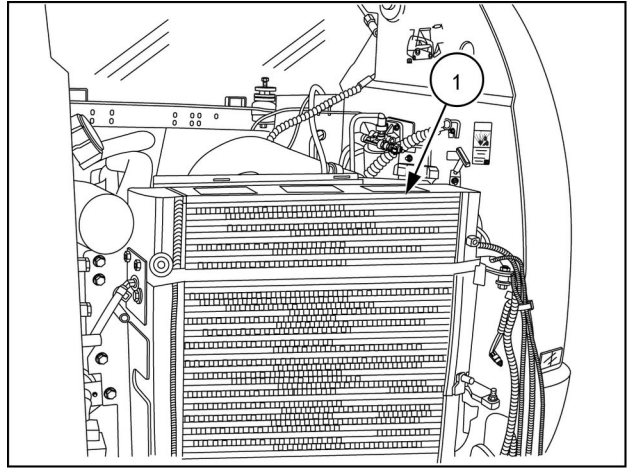

RAPH12SSL0067AA 8

13. Disconnect the upper radiator hose (1) from the radiator.

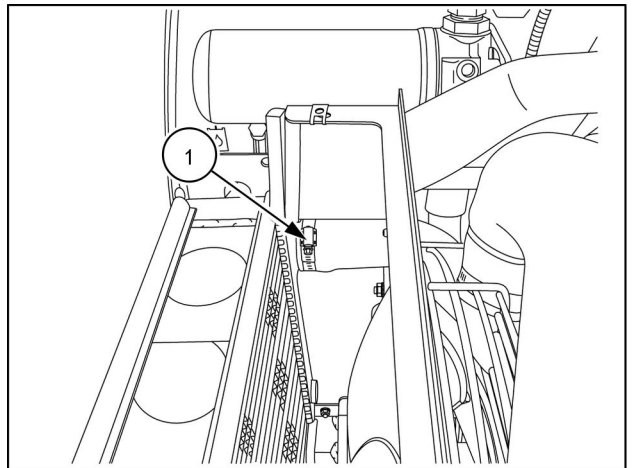

RAPH12SSL0065AA 9

14. Disconnect the lower radiator hose (1) from the radiator.

NOTE: The rear access door has been removed for picture clarity.

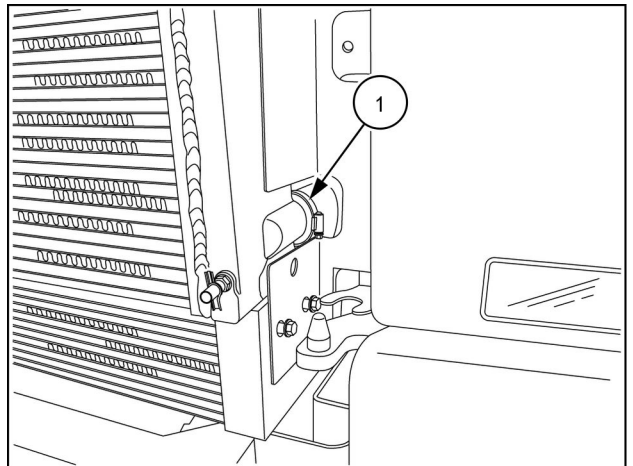

RAPH12SSL0083AA 10

15. Remove the radiator (2) from the shroud.

16.

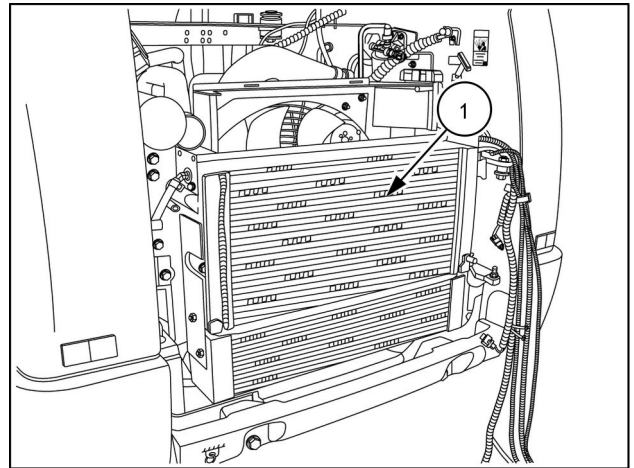

RAPH12SSL0066AA 11

17. Remove the radiator fan (1) from the engine.

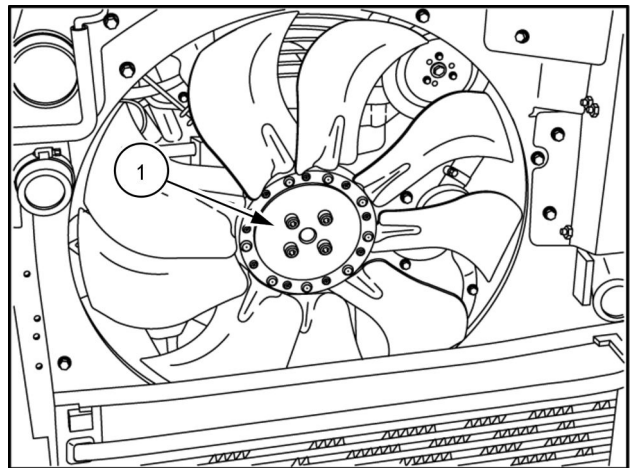

RAPH12SSL0062AA 12

18. Unbolt and remove the shroud (1).

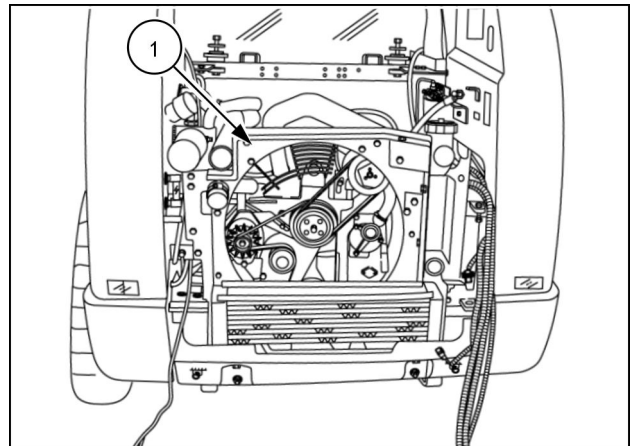

RAPH12SSL0264AA 13



Suggest:

If the above button click is invalid.

Please download this document

first, and then click the above link

to download the complete manual.

Thank you so much for reading

19. Remove the oil cooler (1).

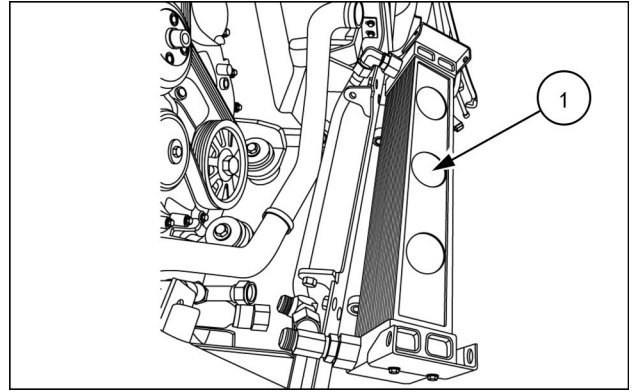

931001884 14

20. Remove the mounting bolts (1) retaining the mounting flange for the muffler inlet pipe to the turbocharger.

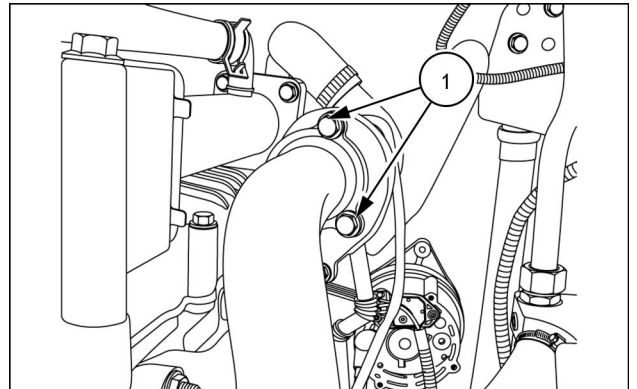

931001896 15

21. Remove the retaining bolts (1) from the muffler support.

22. Remove the muffler.

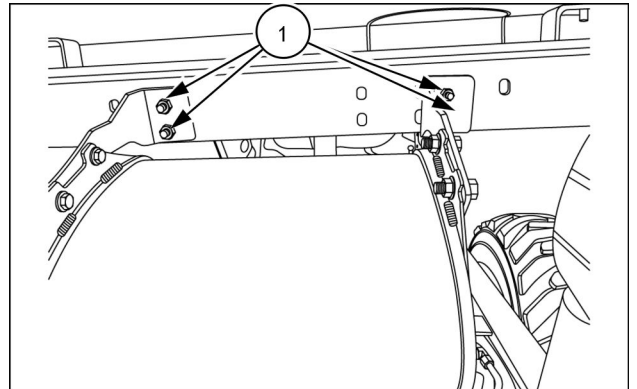

931001895 16

23. Disconnect the air restriction sensor (1) from the wiring harness.

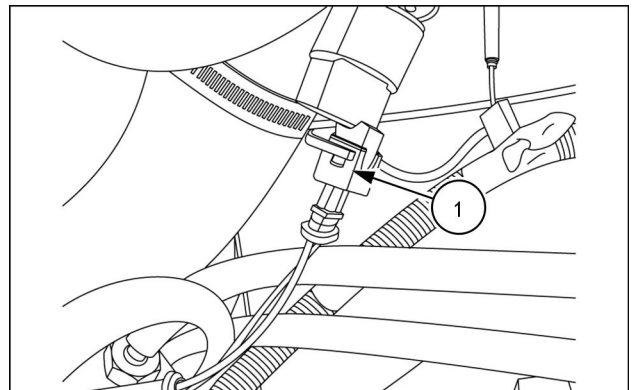

931002030 17

<https://www.ebooklibonline.com>

Hello dear friend!

Thank you very much for reading.

Enter the link into your browser.

The full manual is available for immediate download.

<https://www.ebooklibonline.com>