

SERVICE MANUAL

L218

L220

Tier 4B (final)

200 Series Skid Steer Loader

*L218 PIN NEM476231 and above
L220 PIN NEM475087 and above*

Part number 47711684

1st editon English
May 2014





SERVICE MANUAL

L218 TIER 4 [NEM476231 -]

L220 TIER 4 [NEM475087 -]

Link Product / Engine

Product	Market Product	Engine
L218 TIER 4 [NEM476231 -]	Europe	N4LDI-TA-45SL
L220 TIER 4 [NEM475087 -]	Europe	N4LDI-TA-50SL

<https://www.ebooklibonline.com>

Hello dear friend!

Thank you very much for reading.

Enter the link into your browser.

The full manual is available for immediate download.

<https://www.ebooklibonline.com>

Contents

INTRODUCTION

Engine.....	10
[10.001] Engine and crankcase	10.1
[10.414] Fan and drive	10.2
Front axle system	25
[25.450] Chain drive system.....	25.1
Rear axle system.....	27
[27.650] Chain drive system	27.1
Hydrostatic drive.....	29
[29.202] Hydrostatic transmission	29.1
[29.134] Two-speed assembly.....	29.2
[29.200] Mechanical control	29.3
[29.218] Pump and motor components.....	29.4
Brakes and controls	33
[33.110] Parking brake or parking lock	33.1
Hydraulic systems.....	35
[35.000] Hydraulic systems.....	35.1
[35.104] Fixed displacement pump.....	35.2
[35.128] Auxiliary hydraulic function control	35.3
[35.300] Reservoir, cooler, and filters.....	35.4
[35.350] Safety and main relief valves	35.5
[35.359] Main control valve	35.6
[35.600] High flow hydraulics.....	35.7
[35.701] Front loader arm hydraulic system	35.8
[35.723] Front loader bucket hydraulic system	35.9
[35.724] Front loader hydraulic system control.....	35.10

[35.734] Tool quick coupler hydraulic system	35.11
Frames and ballasting	39
[39.140] Ballasts and supports	39.1
Wheels	44
[44.511] Front wheels.....	44.1
[44.520] Rear wheels.....	44.2
Cab climate control	50
[50.100] Heating.....	50.1
[50.200] Air conditioning	50.2
Electrical systems	55
[55.000] Electrical system	55.1
[55.010] Fuel injection system.....	55.2
[55.011] Fuel tank system	55.3
[55.012] Engine cooling system	55.4
[55.014] Engine intake and exhaust system.....	55.5
[55.015] Engine control system.....	55.6
[55.019] Hydrostatic drive control system	55.7
[55.031] Parking brake electrical system	55.8
[55.036] Hydraulic system control	55.9
[55.100] Harnesses and connectors.....	55.10
[55.302] Battery.....	55.11
[55.404] External lighting	55.12
[55.512] Cab controls.....	55.13
[55.525] Cab engine controls.....	55.14
[55.640] Electronic modules.....	55.15
[55.DTC] FAULT CODES.....	55.16
Front loader and bucket.....	82
[82.100] Arm.....	82.1

[82.300] Bucket	82.2
Platform, cab, bodywork, and decals	90
[90.154] Cab doors and hatches	90.1



INTRODUCTION

Foreword - Important notice regarding equipment servicing

L218	WE
L220	WE

All repair and maintenance work listed in this manual must be carried out only by qualified dealership personnel, strictly complying with the instructions given, and using, whenever possible, the special tools.

Anyone who performs repair and maintenance operations without complying with the procedures provided herein shall be responsible for any subsequent damages.

The manufacturer and all the organizations of its distribution chain, including - without limitation - national, regional, or local dealers, reject any responsibility for damages caused by parts and/or components not approved by the manufacturer, including those used for the servicing or repair of the product manufactured or marketed by the manufacturer. In any case, no warranty is given or attributed on the product manufactured or marketed by the manufacturer in case of damages caused by parts and/or components not approved by the manufacturer.

The information in this manual is up-to-date at the date of the publication. It is the policy of the manufacturer for continuous improvement. Some information could not be updated due to modifications of a technical or commercial type, or changes to the laws and regulations of different countries.

In case of questions, refer to your NEW HOLLAND CONSTRUCTION Sales and Service Networks.

Safety rules

L218	WE
L220	WE

Personal safety





This is the safety alert symbol. It is used to alert you to potential personal injury hazards. Obey all safety messages that follow this symbol to avoid possible death or injury.

Throughout this manual you will find the signal words DANGER, WARNING, and CAUTION followed by special instructions. These precautions are intended for the personal safety of you and those working with you.

Read and understand all the safety messages in this manual before you operate or service the machine.

 DANGER indicates a hazardous situation that, if not avoided, will result in death or serious injury.

 WARNING indicates a hazardous situation that, if not avoided, could result in death or serious injury.

 CAUTION indicates a hazardous situation that, if not avoided, could result in minor or moderate injury.

FAILURE TO FOLLOW DANGER, WARNING, AND CAUTION MESSAGES COULD RESULT IN DEATH OR SERIOUS INJURY.

Machine safety

NOTICE: Notice indicates a situation that, if not avoided, could result in machine or property damage.

Throughout this manual you will find the signal word Notice followed by special instructions to prevent machine or property damage. The word Notice is used to address practices not related to personal safety.

Information

NOTE: Note indicates additional information that clarifies steps, procedures, or other information in this manual.

Throughout this manual you will find the word Note followed by additional information about a step, procedure, or other information in the manual. The word Note is not intended to address personal safety or property damage.

Safety rules - Personal safety

L218	WE
L220	WE

Carefully study these precautions, and those included in the external attachment operators manual, and insist that they be followed by those working with and for you.

1. Thoroughly read and understand this manual and the attachment Operator's Manual before operating this or any other equipment.
2. Be sure all people and pets are clear of the machine before starting. Sound the horn, if equipped, three times before starting engine.
3. Only the operator should be on the machine when in operation. Never allow anyone to climb on to the machine while it is in motion. If the machine is equipped with an Instructors Seat, this must only be used for training purposes. Passengers must not be allowed to use the Instructors Seat.
4. Keep all shields in place. Never work around the machine or any of the attachments while wearing loose clothing that might catch on moving parts.
5. Observe the following precautions whenever lubricating the machine or making adjustments.
 - Disengage all clutching levers or switches.
 - Lower the attachment, if equipped, to the ground or raise the attachment completely and engage the cylinder safety locks. Completing these actions will prevent the attachment from lowering unexpectedly.
 - Engage the parking brake.
 - Shut off the engine and remove the key.
 - Wait for all machine movement to stop before leaving the operators platform.
6. Always keep the machine in gear while travelling downhill.
7. The machine should always be equipped with sufficient front or rear axle weight for safe operation.
8. Under some field conditions, more weight may be required at the front or rear axle for adequate stability. This is especially important when operating in hilly conditions or/when using heavy attachments.
9. Always lower the attachment, shut off the engine, set the parking brake, engage the transmission gears, remove the key and wait for all machine movement to stop before leaving the operators platform.
10. If the attachment or machine should become obstructed or plugged; set the parking brake, shut off the engine and remove the key, engage the transmission gears, wait for all machine or attachment motion to come to a stop, before leaving the operators platform to removing the obstruction or plug.
11. Never disconnect or make any adjustments to the hydraulic system unless the machine and/or the attachment is lowered to the ground or the safety lock(s) is in the engaged position.
12. Use of the flashing lights is highly recommended when operating on a public road.
13. When transporting on a road or highway, use accessory lights and devices for adequate warning to the operators of other vehicles. In this regard, check local government regulations. Various safety lights and devices are available from your NEW HOLLAND CONSTRUCTION dealer.
14. Practice safety 365 days a year.
15. Keep all your equipment in safe operating condition.
16. Keep all guards and safety devices in place.
17. Always set the parking brake, shut off the engine and remove the key, engage the transmission gears, wait for all machine or attachment motion to come to a stop, before leaving the operators platform to service the machine and attachment.
18. Remember: A careful operator is the best insurance against an accident.
19. Extreme care should be taken in keeping hands and clothing away from moving parts.



SERVICE MANUAL

Engine

L218 TIER 4 [NEM476231 -]

L220 TIER 4 [NEM475087 -]

Engine - Drain fluid

L218 TIER 4 [NEM476231 -]	WE
L220	WE

1. Remove the access cover at the rear, lower left of the machine, exposing the engine oil drain hose and remote oil filter.
2. Remove the drain plug to drain the oil.
3. When the oil has completely drained, reinstall the drain plug and torque to **68 - 82 N·m (50 - 61 lb ft)**.

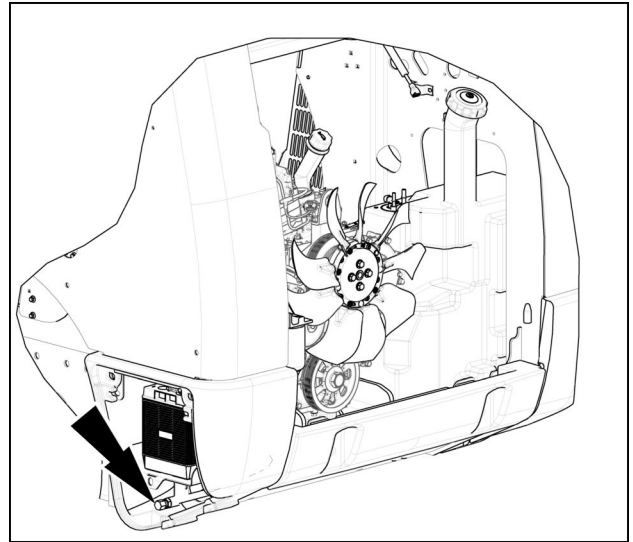

63109370 1

Engine - Remove

⚠ WARNING

Avoid injury! Always do the following before lubricating, maintaining, or servicing the machine.

1. Disengage all drives.
2. Engage parking brake.
3. Lower all attachments to the ground, or raise and engage all safety locks.
4. Shut off engine.
5. Remove key from key switch.
6. Switch off battery key, if installed.
7. Wait for all machine movement to stop.

Failure to comply could result in death or serious injury.

W0047A

⚠ WARNING

Fire hazard!

When handling diesel fuel, observe the following precautions:

1. Do not smoke.
2. Never fill the tank when the engine is running.
3. Wipe up spilled fuel immediately.

Failure to comply could result in death or serious injury.

W0099A

⚠ DANGER

Heavy objects!

Lift and handle all heavy components using lifting equipment with adequate capacity. Always support units or parts with suitable slings or hooks. Make sure the work area is clear of all bystanders.

Failure to comply will result in death or serious injury.

D0076A

Prior operation:

Tilt the Roll Over Protection Structure (ROPS).

Prior operation:

Disconnect the battery. See **Battery - Disconnect (55.302)**.

Prior operation:

Drain the coolant. See

Prior operation:

Drain the oil.

Prior operation:

Recover the A/C refrigerant (if applicable). See **Air conditioning - Evacuate (50.200)**

1. Remove the external, rear trim panels (1).

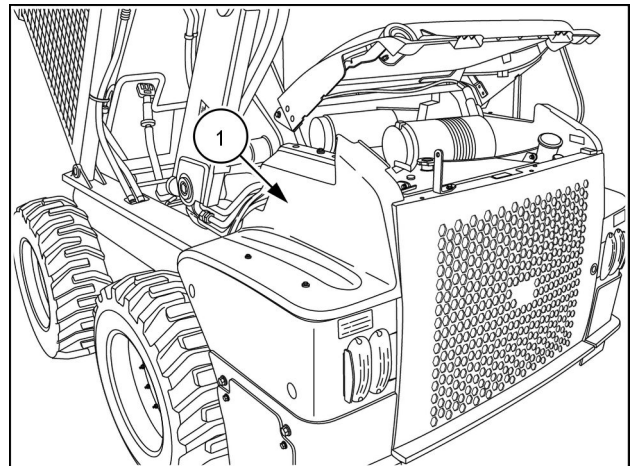

RAIL13SSL0148AA 1

Engine - Engine and crankcase

2. Remove the engine hood strut from the side by gently prying the retaining clip just enough to release the strut.
3. Disconnect the A/C lines (if applicable).
4. Disconnect the lights and disconnect the harness from the hood.
5. Remove the engine hood mounting hardware from left-hand and right-hand side of the engine hood.
6. Remove the engine hood (1).

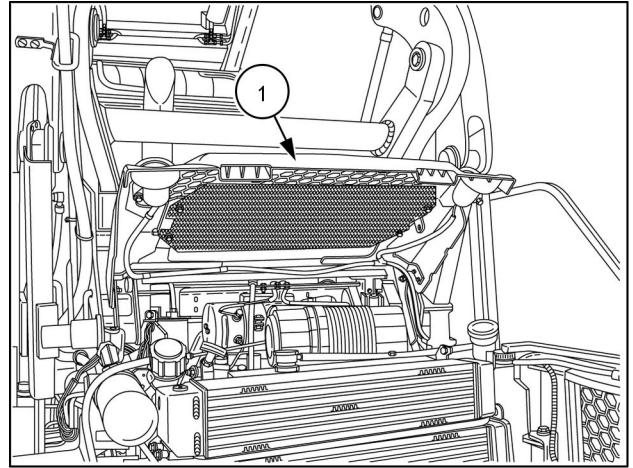

RAIL13SSL0149AA 2

7. Remove the engine cover (1).

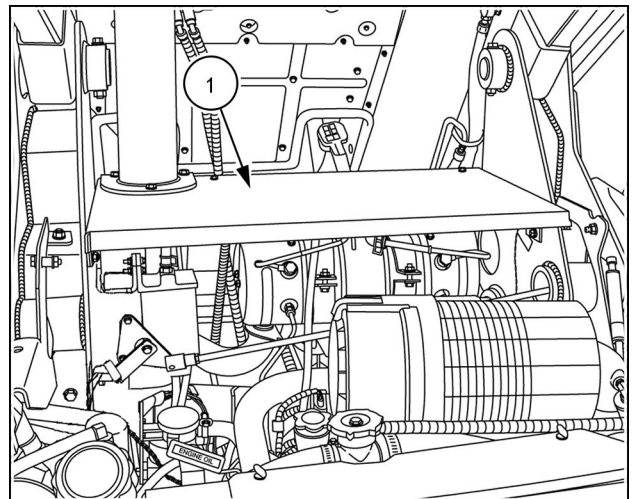

RAIL13SSL0128AA 3

8. Remove the air filter assembly (1) and hoses.

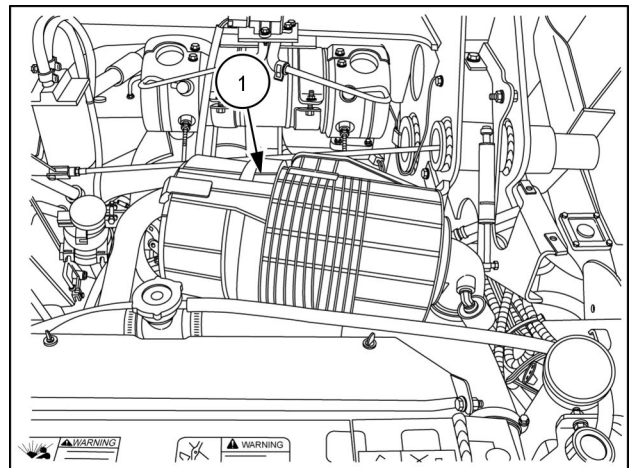

RAIL13SSL0145AA 4

9. Remove the fuel filter assembly **(1)** and plug the hoses.
10. Remove the bracket **(2)** for the air filter assembly.
11. Remove the oil fill tube **(3)**.
12. Disconnect the mount **(4)** for the oil dip stick from the cooling package bracket.
13. For vertical lift machines, remove the cotter pin on the lock pin link for the left boom. Unbolt the boom lock bellcrank **(5)** and place it away from the engine area.

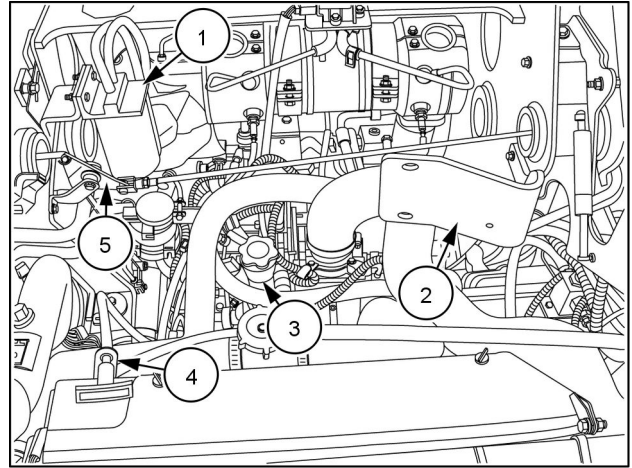

RAIL13SSL0144AA 5

14. Remove the bracket **(1)** for the coolant overflow bottle.

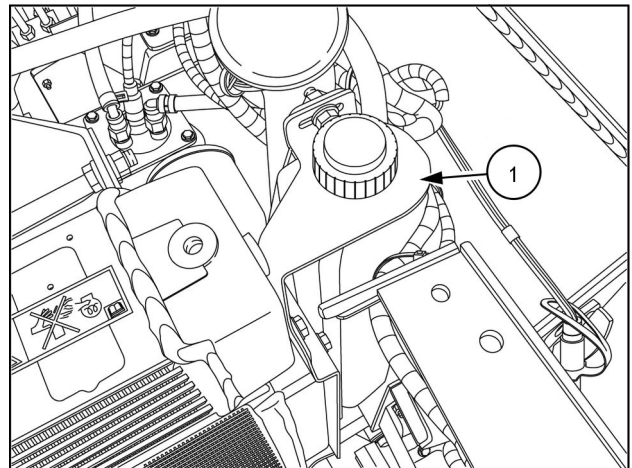

RAIL13SSL0143AA 6

15. Remove the air cooler **(1)**.

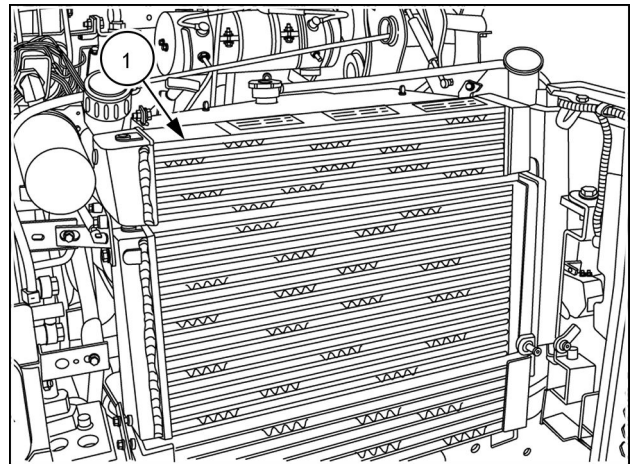

RAIL13SSL0142AA 7

16. Remove the coolant overflow bottle.

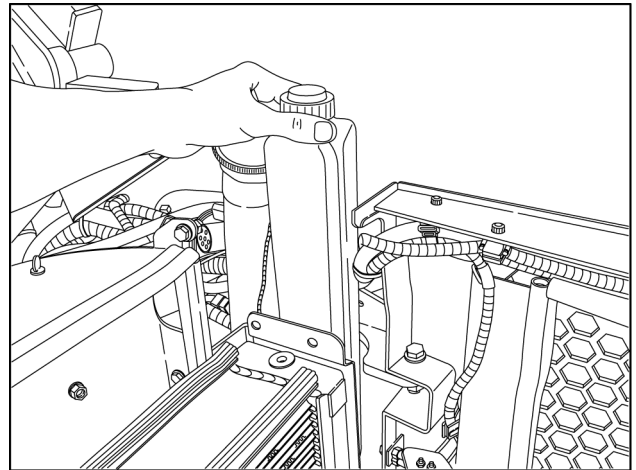

RAIL13SSL0141AA 8

17. Remove the radiator (1).

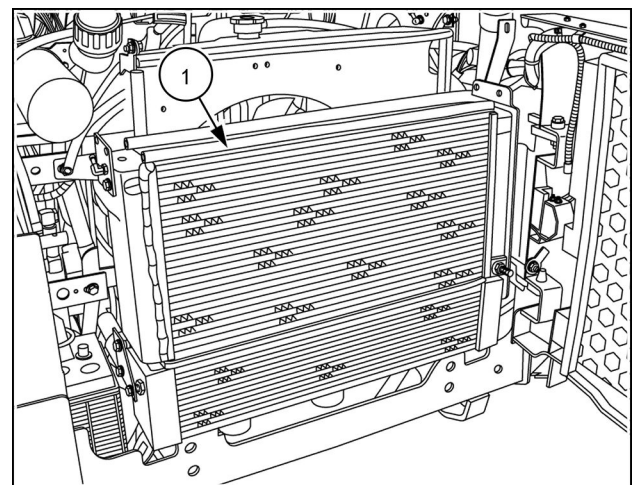

RAIL13SSL0140AA 9

18. Loosen the alternator mounting bolt (3) and the mounting bolt (2) for the adjustment bolt (1).
19. Remove the tension from the belt by turning the adjustment screw (1) on the alternator.

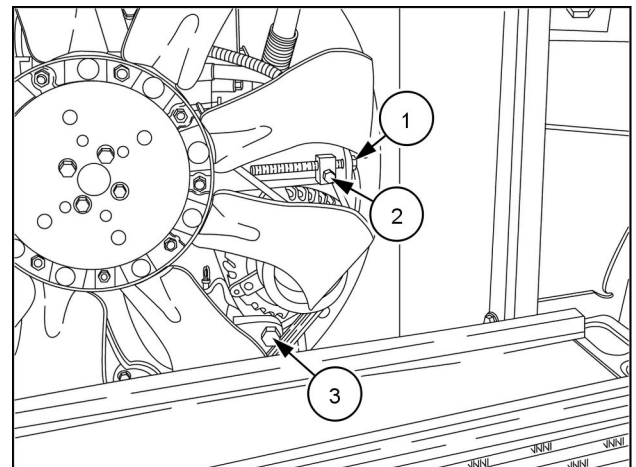

RAIL13SSL0139AA 10



Suggest:

If the above button click is invalid.

Please download this document

first, and then click the above link

to download the complete manual.

Thank you so much for reading

20. Remove the engine fan assembly.

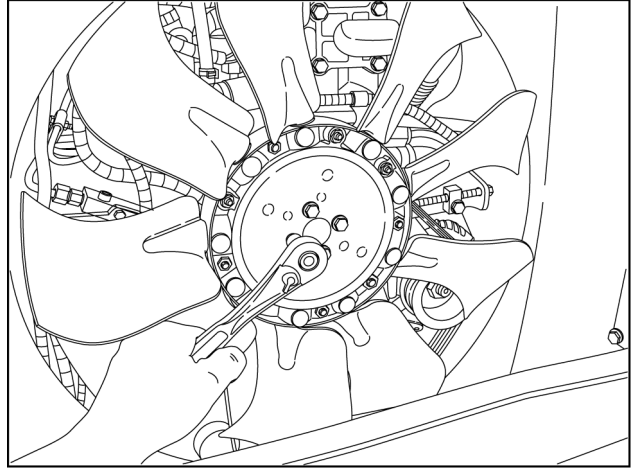

RAIL13SSL0138AA 11

21. Remove the cooling package bracket assembly (1).

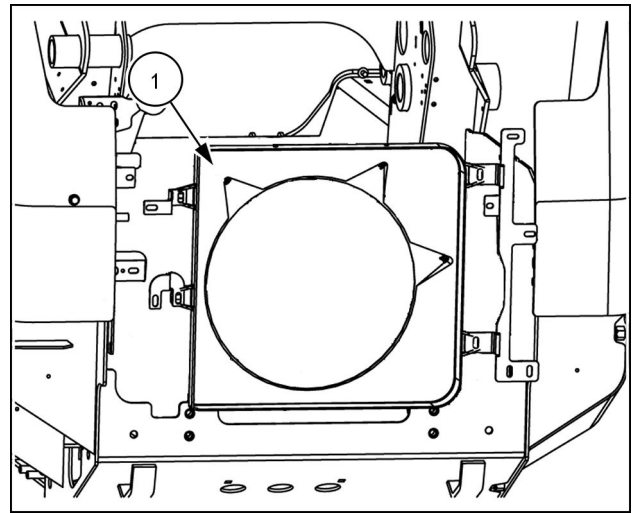

RAIL13SSL0604AA 12

22. Disconnect the positive battery cable (1) on the alternator.
23. Disconnect the electrical connector (2) on the alternator.
24. Disconnect the starter ignition wire (3).
25. Disconnect the positive battery cable (4) on the starter.

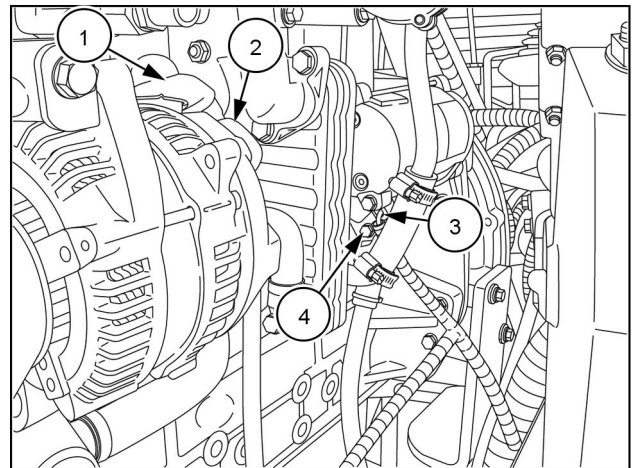

RAIL13SSL0130AA 13

26. If applicable, disconnect the supply and return hoses for the heater core.

NOTE: The supply hose is located on the left-hand side of the engine and the return hose is located on the right-hand side of the engine.

<https://www.ebooklibonline.com>

Hello dear friend!

Thank you very much for reading.

Enter the link into your browser.

The full manual is available for immediate download.

<https://www.ebooklibonline.com>