

# SERVICE MANUAL

## T8.320 / T8.350 / T8.380 / T8.410 / T8.380 SmartTrax™ / T8.410 SmartTrax™ Powershift Transmission (PST) Tractor

*PIN ZGRE05001 and above; PIN ZHRE01013 and above*

**Part number 48115483**

1<sup>st</sup> edition English  
April 2017





## **SERVICE MANUAL**

**T8.320 PST TIER 4B [ZGRE05001 - ], T8.350 PST TIER 4B [ZGRE05001 - ], T8.380 PST TIER 4B [ZGRE05001 - ], T8.380 SmartTrax™ PST TIER 4B [ZGRE05001 - ], T8.410 PST TIER 4B [ZGRE05001 - ], T8.410 SmartTrax™ PST TIER 4B [ZGRE05001 - ]**

## Link Product / Engine

<b>Product</b>	<b>Market Product</b>	<b>Engine</b>
T8.320 PST TIER 4B [ZGRE05001 - ]	North America	F2CFE613G*B002
T8.320 PST TIER 4B [ZGRE05001 - ]	Australia New Zealand	F2CFE613G*B002
T8.350 PST TIER 4B [ZGRE05001 - ]	Australia New Zealand	F2CFE614G*B002
T8.350 PST TIER 4B [ZGRE05001 - ]	North America	F2CFE614G*B002
T8.380 PST TIER 4B [ZGRE05001 - ]	North America	F2CFE614D*B002
T8.380 PST TIER 4B [ZGRE05001 - ]	Australia New Zealand	F2CFE614D*B002
T8.410 PST TIER 4B [ZGRE05001 - ]	Australia New Zealand	F2CFE614C*B002
T8.410 PST TIER 4B [ZGRE05001 - ]	North America	F2CFE614C*B002
T8.380 SmartTrax™ PST TIER 4B [ZGRE05001 - ]	North America	F2CFE614D*B002
T8.380 SmartTrax™ PST TIER 4B [ZGRE05001 - ]	Australia New Zealand	F2CFE614D*B002
T8.410 SmartTrax™ PST TIER 4B [ZGRE05001 - ]	North America	F2CFE614C*B002
T8.410 SmartTrax™ PST TIER 4B [ZGRE05001 - ]	Australia New Zealand	F2CFE614C*B002

**<https://www.ebooklibonline.com>**

Hello dear friend!

Thank you very much for reading.

Enter the link into your browser.

The full manual is available for immediate download.

**<https://www.ebooklibonline.com>**

# Contents

---

## INTRODUCTION

<b>Engine</b> .....	<b>10</b>
[10.001] Engine and crankcase .....	10.1
[10.101] Cylinder heads .....	10.2
[10.202] Air cleaners and lines .....	10.3
[10.206] Fuel filters .....	10.4
[10.216] Fuel tanks .....	10.5
[10.218] Fuel injection system.....	10.6
[10.304] Engine lubrication system.....	10.7
[10.310] Aftercooler.....	10.8
[10.400] Engine cooling system .....	10.9
[10.414] Fan and drive .....	10.10
[10.500] Selective Catalytic Reduction (SCR) exhaust treatment.....	10.11
<b>Power coupling</b> .....	<b>19</b>
[19.100] Drive shaft.....	19.1
[19.110] Flywheel damper .....	19.2
[19.120] Drive shaft shield assembly .....	19.3
<b>Transmission</b> .....	<b>21</b>
[21.105] Powershift transmission hydraulic components .....	21.1
[21.113] Powershift transmission .....	21.2
[21.135] Powershift transmission external controls.....	21.3
[21.155] Powershift transmission internal components.....	21.4
[21.200] Dropbox .....	21.5
[21.900] Hydraulic pump drive.....	21.6
<b>Four-Wheel Drive (4WD) system</b> .....	<b>23</b>
[23.202] Electro-hydraulic control .....	23.1

[23.314] Drive shaft.....	23.2
<b>Front axle system .....</b>	<b>25</b>
[25.100] Powered front axle .....	25.1
[25.102] Front bevel gear set and differential .....	25.2
[25.108] Final drive hub, steering knuckles, and shafts .....	25.3
[25.122] Axle suspension control.....	25.4
<b>Rear axle system.....</b>	<b>27</b>
[27.100] Powered rear axle.....	27.1
[27.106] Rear bevel gear set and differential.....	27.2
[27.120] Planetary and final drives .....	27.3
[27.610] Rear axle track yoke assembly .....	27.4
<b>Power Take-Off (PTO).....</b>	<b>31</b>
[31.104] Rear electro-hydraulic control.....	31.1
[31.110] One-speed rear Power Take-Off (PTO) .....	31.2
[31.114] Two-speed rear Power Take-Off (PTO) .....	31.3
[31.146] Front Power Take-Off (PTO) .....	31.4
<b>Brakes and controls .....</b>	<b>33</b>
[33.110] Parking brake or parking lock .....	33.1
[33.202] Hydraulic service brakes .....	33.2
[33.220] Trailer brake hydraulic control.....	33.3
[33.224] Trailer brake pneumatic control .....	33.4
<b>Hydraulic systems.....</b>	<b>35</b>
[35.000] Hydraulic systems.....	35.1
[35.102] Pump control valves.....	35.2
[35.106] Variable displacement pump .....	35.3
[35.114] Three-point hitch control valve .....	35.4
[35.124] Three-point hitch hydraulic adjustment .....	35.5
[35.204] Remote control valves .....	35.6

[35.300] Reservoir, cooler, and filters.....	35.7
[35.304] Combination pump units .....	35.8
<b>Hitches, drawbars, and implement couplings.....</b>	<b>37</b>
[37.110] Rear three-point hitch .....	37.1
[37.162] Front hitch .....	37.2
<b>Frames and ballasting .....</b>	<b>39</b>
[39.100] Frame .....	39.1
<b>Steering.....</b>	<b>41</b>
[41.101] Steering control .....	41.1
[41.200] Hydraulic control components.....	41.2
[41.206] Pump .....	41.3
[41.432] Autoguidance steering .....	41.4
[41.910] Auxiliary steering .....	41.5
<b>Wheels .....</b>	<b>44</b>
[44.520] Rear wheels.....	44.1
<b>Tracks and track suspension.....</b>	<b>48</b>
[48.100] Tracks .....	48.1
[48.130] Track frame and driving wheels.....	48.2
[48.134] Track tension units .....	48.3
[48.138] Track rollers .....	48.4
<b>Cab climate control .....</b>	<b>50</b>
[50.100] Heating.....	50.1
[50.200] Air conditioning.....	50.2
[50.300] Cab pressurizing system.....	50.3
<b>Electrical systems .....</b>	<b>55</b>
[55.000] Electrical system .....	55.1
[55.010] Fuel injection system.....	55.2

[55.012] Engine cooling system .....	55.3
[55.013] Engine oil system .....	55.4
[55.014] Engine intake and exhaust system.....	55.5
[55.015] Engine control system.....	55.6
[55.024] Transmission control system .....	55.7
[55.045] Front axle control system .....	55.8
[55.047] Steering control system .....	55.9
[55.050] Heating, Ventilation, and Air-Conditioning (HVAC) control system.....	55.10
[55.100] Harnesses and connectors.....	55.11
[55.130] Rear three-point hitch electronic control system .....	55.12
[55.302] Battery.....	55.13
[55.408] Warning indicators, alarms, and instruments .....	55.14
[55.512] Cab controls.....	55.15
[55.640] Electronic modules .....	55.16
[55.988] Selective Catalytic Reduction (SCR) electrical system .....	55.17
[55.DTC] FAULT CODES.....	55.18
<b>Platform, cab, bodywork, and decals .....</b>	<b>90</b>
[90.100] Engine hood and panels .....	90.1
[90.102] Engine shields, hood latches, and trims .....	90.2
[90.124] Pneumatically-adjusted operator seat.....	90.3
[90.150] Cab.....	90.4
[90.151] Cab interior.....	90.5
[90.160] Cab interior trim and panels.....	90.6



# INTRODUCTION

---

## **Foreword - Important notice regarding equipment servicing**

All repair and maintenance work listed in this manual must be carried out only by qualified dealership personnel, strictly complying with the instructions given, and using, whenever possible, the special tools.

Anyone who performs repair and maintenance operations without complying with the procedures provided herein shall be responsible for any subsequent damages.

The manufacturer and all the organizations of its distribution chain, including - without limitation - national, regional, or local dealers, reject any responsibility for damages caused by parts and/or components not approved by the manufacturer, including those used for the servicing or repair of the product manufactured or marketed by the manufacturer. In any case, no warranty is given or attributed on the product manufactured or marketed by the manufacturer in case of damages caused by parts and/or components not approved by the manufacturer.

The manufacturer reserves the right to make improvements in design and changes in specifications at any time without notice and without incurring any obligation to install them on units previously sold. Specifications, descriptions, and illustrative material herein are as accurate as known at time of publication but are subject to change without notice.

In case of questions, refer to your NEW HOLLAND Sales and Service Networks.

## Safety rules

### Personal safety



This is the safety alert symbol. It is used to alert you to potential personal injury hazards. Obey all safety messages that follow this symbol to avoid possible death or injury.

Throughout this manual you will find the signal words DANGER, WARNING, and CAUTION followed by special instructions. These precautions are intended for the personal safety of you and those working with you.

Read and understand all the safety messages in this manual before you operate or service the machine.

 DANGER indicates a hazardous situation that, if not avoided, will result in death or serious injury.

 WARNING indicates a hazardous situation that, if not avoided, could result in death or serious injury.

 CAUTION indicates a hazardous situation that, if not avoided, could result in minor or moderate injury.

**FAILURE TO FOLLOW DANGER, WARNING, AND CAUTION MESSAGES COULD RESULT IN DEATH OR SERIOUS INJURY.**

### Machine safety

**NOTICE:** Notice indicates a situation that, if not avoided, could result in machine or property damage.

Throughout this manual you will find the signal word Notice followed by special instructions to prevent machine or property damage. The word Notice is used to address practices not related to personal safety.

### Information

**NOTE:** Note indicates additional information that clarifies steps, procedures, or other information in this manual.

Throughout this manual you will find the word Note followed by additional information about a step, procedure, or other information in the manual. The word Note is not intended to address personal safety or property damage.

---

## Safety rules - General maintenance safety

### General maintenance safety

Keep the area used for servicing the machine clean and dry. Clean up spilled fluids.

Service the machine on a firm, level surface.

Install guards and shields after you service the machine.

Close all access doors and install all panels after servicing the machine.

Do not attempt to clean, lubricate, clear obstructions, or make adjustments to the machine while it is in motion or while the engine is running.

Always make sure that working area is clear of tools, parts, other persons and pets before you start operating the machine.

Unsupported hydraulic cylinders can lose pressure and drop the equipment, causing a crushing hazard. Do not leave equipment in a raised position while parked or during service, unless the equipment is securely supported.

Jack or lift the machine only at jack or lift points indicated in this manual.

Incorrect towing procedures can cause accidents. When you tow a disabled machine follow the procedure in this manual. Use only rigid tow bars.

Stop the engine, remove the key, and relieve pressure before you connect or disconnect fluid lines.

Stop the engine and remove the key before you connect or disconnect electrical connections.

Scalding can result from incorrect removal of coolant caps. Cooling systems operate under pressure. Hot coolant can spray out if you remove a cap while the system is hot. Allow the system to cool before you remove the cap. When you remove the cap, turn it slowly to allow pressure to escape before you completely remove the cap.

Replace damaged or worn tubes, hoses, electrical wiring, etc.

The engine, transmission, exhaust components, and hydraulic lines may become hot during operation. Take care when you service such components. Allow surfaces to cool before you handle or disconnect hot components. Wear protective equipment when appropriate.

When welding, follow the instructions in the manual. Always disconnect the battery before you weld on the machine. Always wash your hands after you handle battery components.

## Product identification - Machine orientation

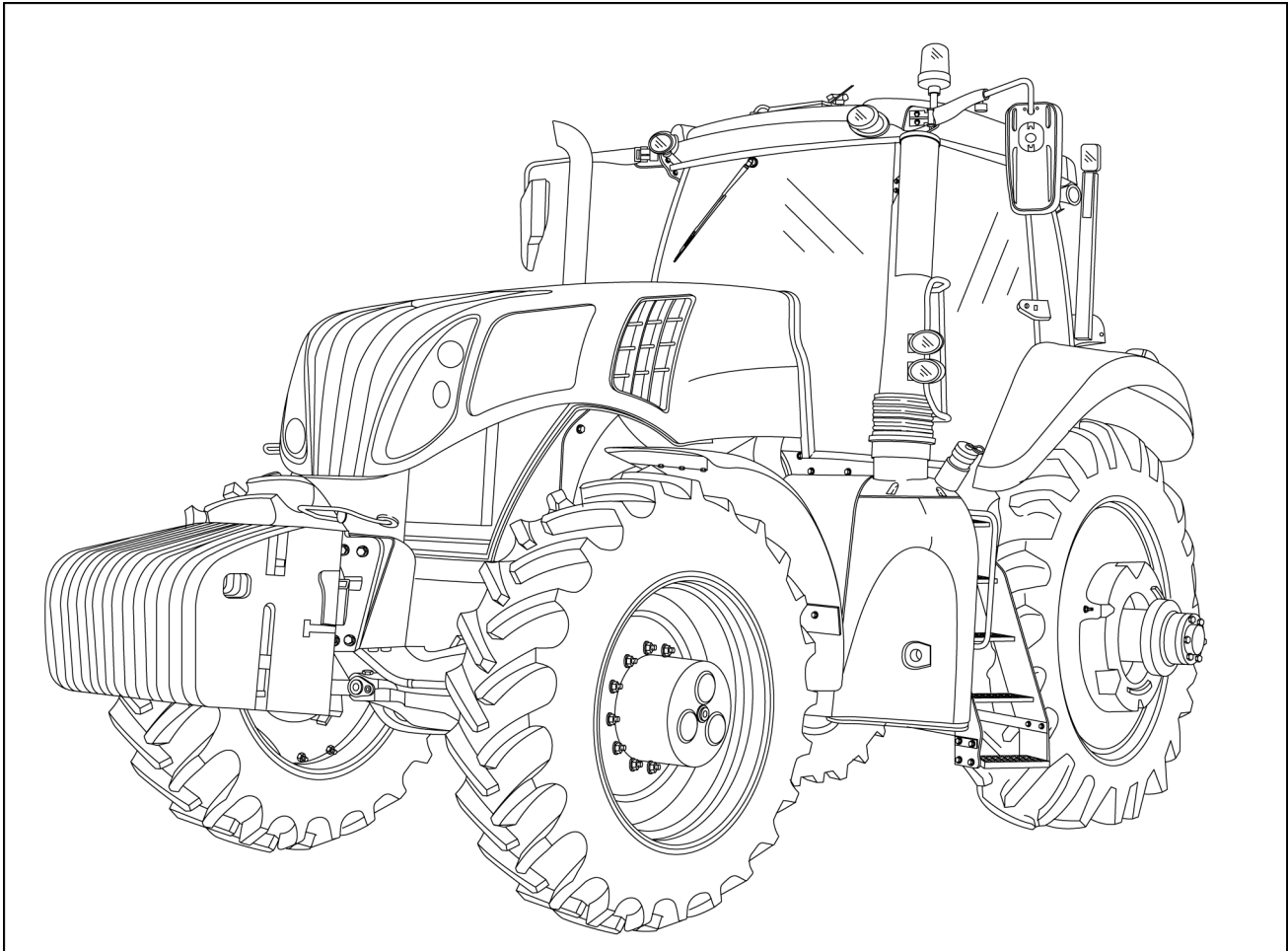

RAIL14TR02056GA 1

The right hand and left hand side of the tractor used in this manual are the same as your right hand and left hand when sitting in the tractor seat looking forward.



# **SERVICE MANUAL**

## **Engine**

**T8.320 PST TIER 4B [ZGRE05001 - ], T8.350 PST TIER 4B [ZGRE05001 - ], T8.380 PST TIER 4B [ZGRE05001 - ], T8.380 SmartTrax™ PST TIER 4B [ZGRE05001 - ], T8.410 PST TIER 4B [ZGRE05001 - ], T8.410 SmartTrax™ PST TIER 4B [ZGRE05001 - ]**

## Visual external differences for T8. tractor engines

There are a few things that make the FPT **Cursor® 9** engine used in the T8. tractors visually and mechanically different from other **Cursor® 9** applications.

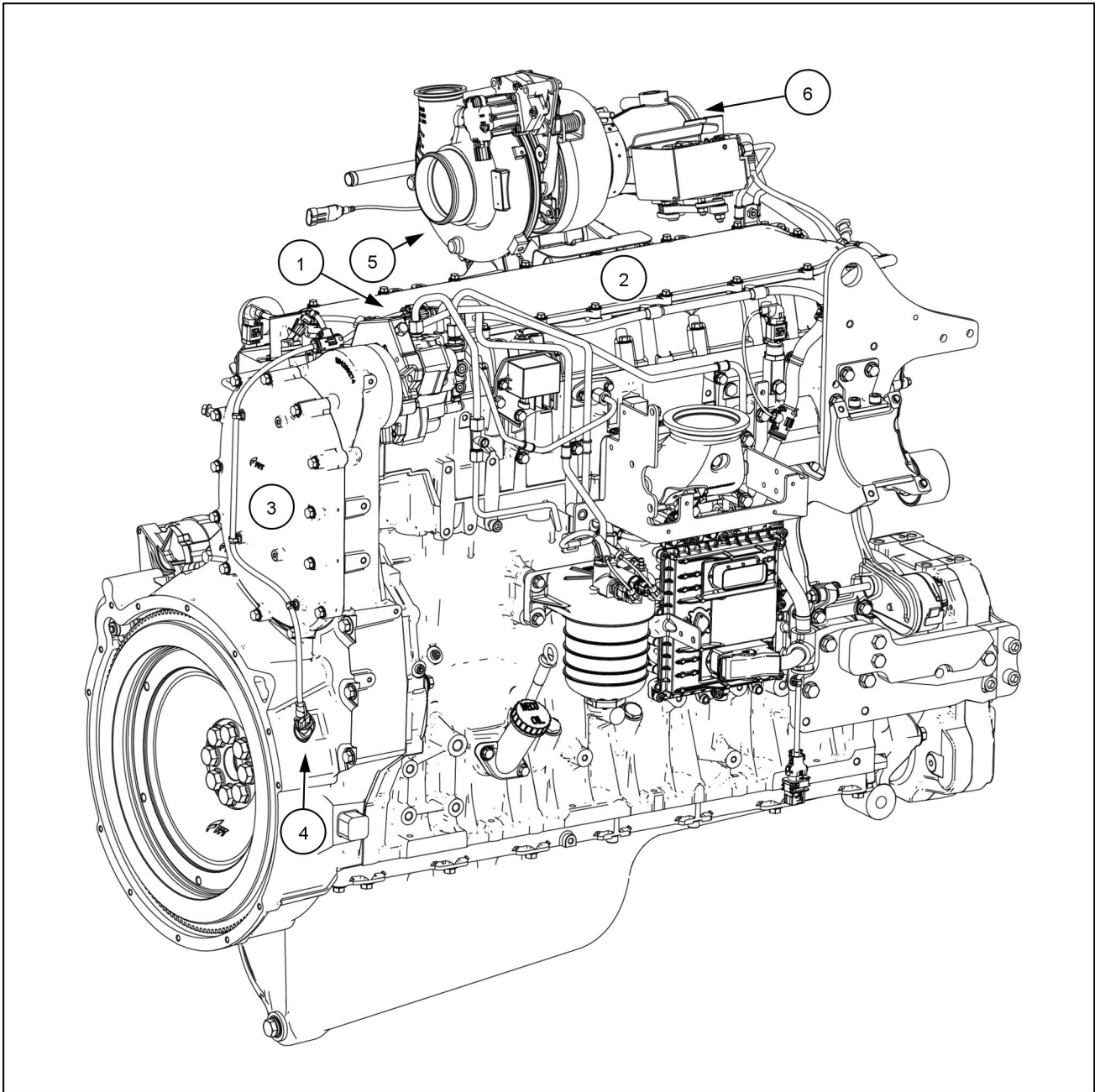

RAIL15TR00608GA 3

1. The fuel pump sits higher and closet to the center line of the engine.
2. A two piece valve cover assembly that allows for valve adjustment without removing the entire cover.
3. The rear cover is an oval shape where on other **Cursor® 9** engines it's round.
4. The flywheel speed sensor is located on the right side of the engine, others have on the left side of the engine.
5. The turbocharger is moved higher and toward the center line of the engine.
6. Exhaust flap for TIER 4B.

## Exhaust brake

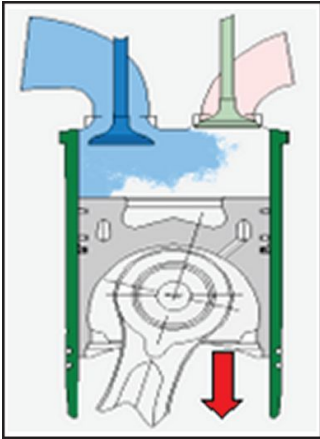

**Admission phase:**  
Intake of fresh air.

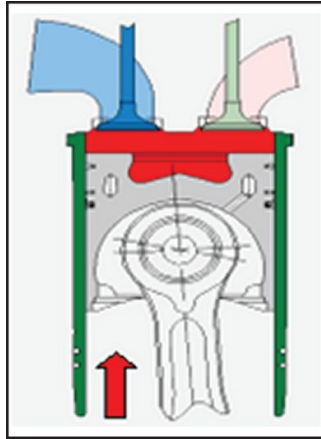

**Compression phase:**  
Energy is stored in the compressed air, braking effect increases with compression

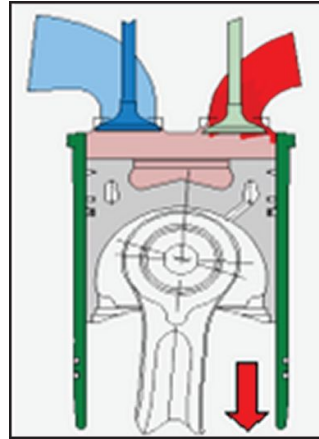

**Top dead center:**  
Exhaust valves open, compressed air is released, energy is blown out.

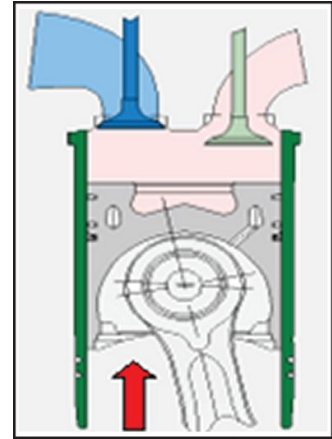

**Exhaust phase:**  
Cylinder is empty, no energy exchange. Exhaust gases impact against the turbine, creating an additional braking effect.

All **Cursor®** engines are equipped with an advanced engine brake system: the Iveco Turbo Brake (IBT) system.

- Decompression engine brake
- Quick responding
- Integrated in the engine control
- Linked to cruise control
- Linked to EBS

### Advantage

- Less brake pad wear
- Automatically engaged

### Benefit

- Reduced operation cost
- Operator ease

The engine brake is controlled by the Tractor Control Unit (TCU). The Electronic Service Tool (EST) is used to configure the TCU as to whether or not the tractor has an engine brake.

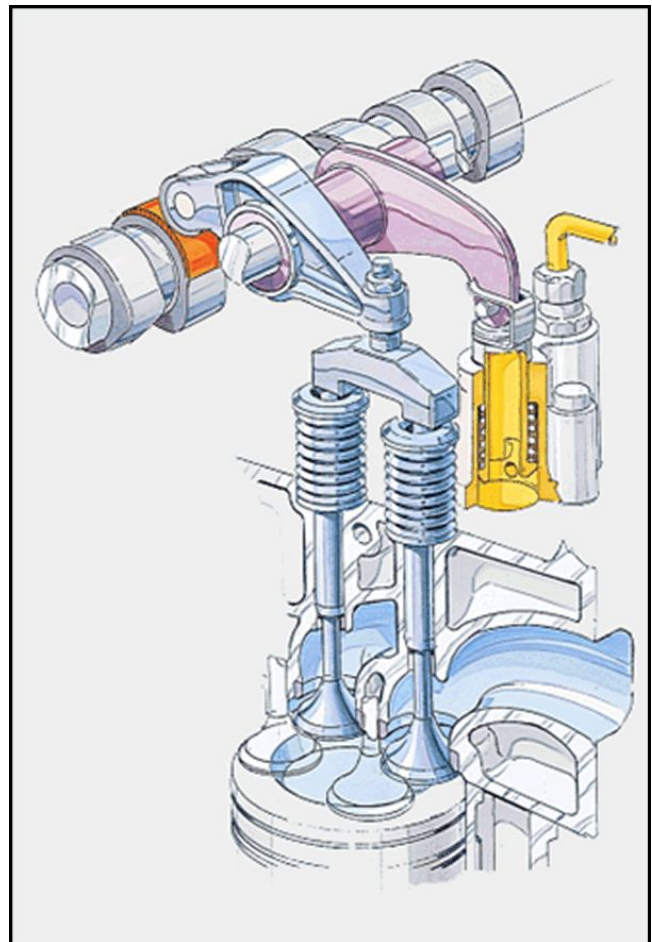

The engine brake is activated when the pedal left of the clutch is depressed.

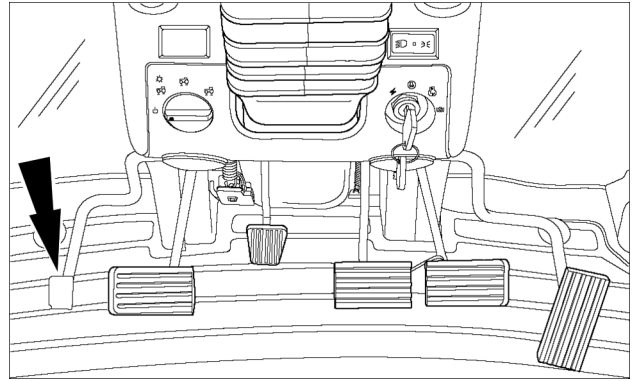

RCPH11CCH481AAA 4

### Air Induction - cross flow cylinder head

The cylinder head is of the cross flow design, inlet on one side and exhaust on the other. This and four valves per cylinder give it excellent breathing ability and efficient temperature control. The air is supplied to the inlet by a wastegate turbocharger or a Variable Geometry Turbocharger (VGT).

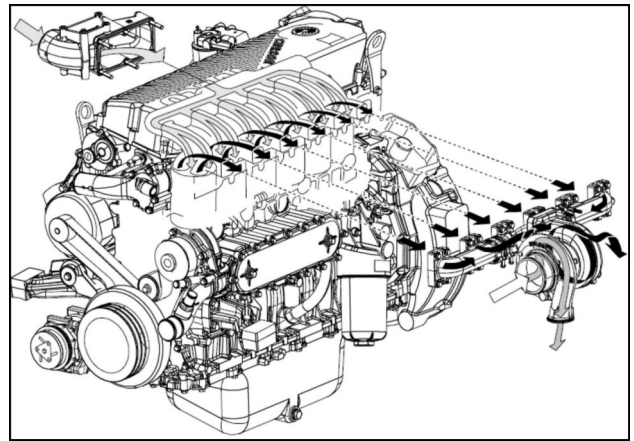

RAIL15TR00376BA 5

### Wastegate turbocharger

The wastegate turbocharger allows for a larger turbocharger to be installed producing higher boost pressures in the low and midrange rpm while not over-boosting at high rpm.

Intake pressure builds against a diaphragm in the wastegate and opens a valve allowing exhaust to bypass the turbine therefore slowing the compressor and limiting the pressure in the intake manifold.

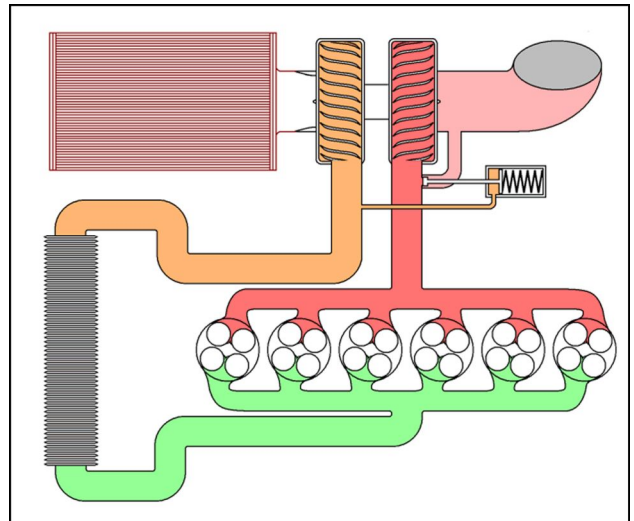

RAIL15TR00396BA 6



**Suggest:**

**If the above button click is invalid.**

**Please download this document**

**first, and then click the above link**

**to download the complete manual.**

**Thank you so much for reading**

## Electronically Variable Geometry Turbocharger (eVGT)

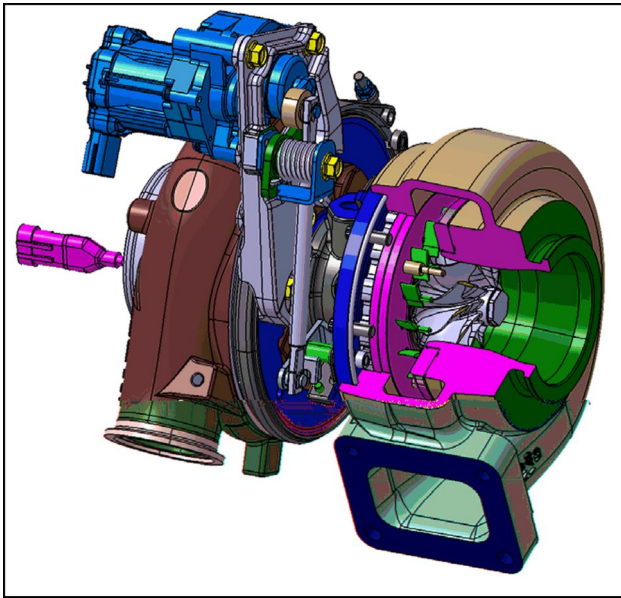

RAIL15TR00383BA 7

The electronically Variable Geometry Turbocharger (eVGT) is used on the TIER 4A T8.420 and TIER 4B T8.350, T8.380, T8.410 and T8.435. The eVGT is electronically controlled by the Engine Control Unit (ECU).

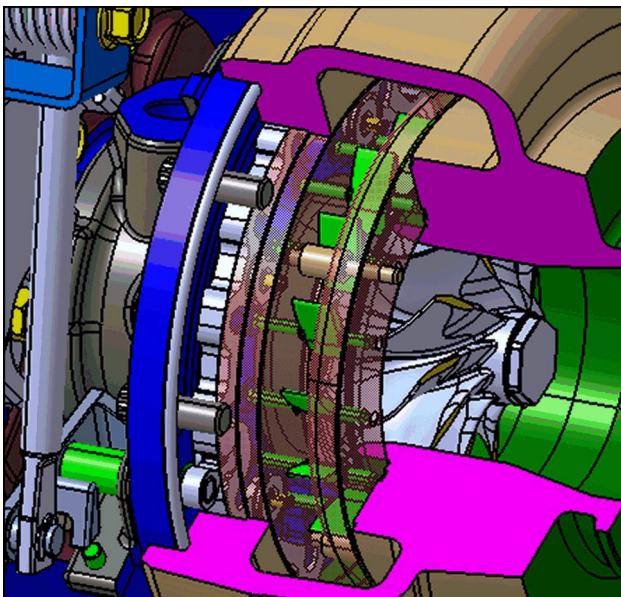

RAIL15TR00395BA 8

Vanes open (low boost)

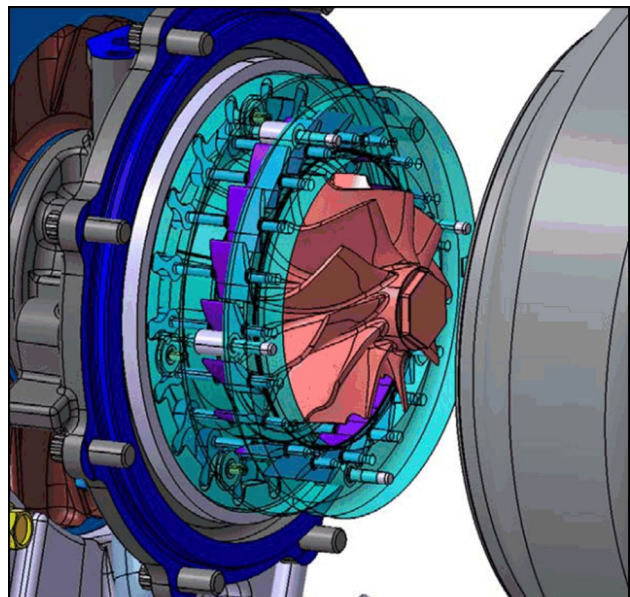

RAIL15TR00394BA 9

Vanes closed (high boost)

The eVGT uses a series of aerodynamic vanes to direct exhaust toward the turbine controlling both the velocity and angle the exhaust contacts the turbine. This gives the ECU the ability to dynamically “tune” the boost pressure at any given engine speed and load, Improving performance and fuel economy.

Fully open the velocity slows and the angle is decreased therefore the turbine and compressor turn slower producing less boost. When needed, the vanes close increasing the velocity and angle, therefore increasing turbine and compressor speed, producing higher boost anytime it is needed across the entire operating range of the engine.

**<https://www.ebooklibonline.com>**

Hello dear friend!

Thank you very much for reading.

Enter the link into your browser.

The full manual is available for immediate download.

**<https://www.ebooklibonline.com>**