

SERVICE MANUAL

**T8.320 / T8.350 / T8.380 / T8.410 /
T8.380 SmartTrax™ / T8.410 SmartTrax™
Powershift Transmission (PST)
Tractor**

PIN ZJRE04001 and above

Part number 51537935

1st edition English
November 2018





SERVICE MANUAL

T8.320 PST TIER 4B [ZJRE04001 -], T8.350 PST TIER 4B [ZJRE04001 -], T8.380 PST TIER 4B [ZJRE04001 -], T8.380 SmartTrax™ PST TIER 4B [ZJRE04001 -], T8.410 PST TIER 4B [ZJRE04001 -], T8.410 SmartTrax™ PST TIER 4B [ZJRE04001 -]

Link Product / Engine

Product	Market Product	Engine
T8.320 PST TIER 4B [ZJRE04001 -]	Latin America	F2CFE613G*B002
T8.320 PST TIER 4B [ZJRE04001 -]	North America	F2CFE613G*B002
T8.320 PST TIER 4B [ZJRE04001 -]	Middle East Africa	F2CFE613G*B002
T8.320 PST TIER 4B [ZJRE04001 -]	Australia New Zealand	F2CFE613G*B002
T8.350 PST TIER 4B [ZJRE04001 -]	North America	F2CFE614G*B003
T8.350 PST TIER 4B [ZJRE04001 -]	Latin America	F2CFE614G*B003
T8.350 PST TIER 4B [ZJRE04001 -]	Australia New Zealand	F2CFE614G*B003
T8.350 PST TIER 4B [ZJRE04001 -]	Middle East Africa	F2CFE614G*B003
T8.380 PST TIER 4B [ZJRE04001 -]	Middle East Africa	F2CFE614D*B002
T8.380 PST TIER 4B [ZJRE04001 -]	Latin America	F2CFE614D*B002
T8.380 PST TIER 4B [ZJRE04001 -]	Australia New Zealand	F2CFE614D*B002
T8.380 PST TIER 4B [ZJRE04001 -]	North America	F2CFE614D*B002
T8.410 PST TIER 4B [ZJRE04001 -]	Australia New Zealand	F2CFE614C*B002
T8.410 PST TIER 4B [ZJRE04001 -]	Middle East Africa	F2CFE614C*B002
T8.410 PST TIER 4B [ZJRE04001 -]	Latin America	F2CFE614C*B002
T8.410 PST TIER 4B [ZJRE04001 -]	North America	F2CFE614C*B002
T8.380 SmartTrax™ PST TIER 4B [ZJRE04001 -]	Australia New Zealand	F2CFE614D*B002
T8.380 SmartTrax™ PST TIER 4B [ZJRE04001 -]	North America	F2CFE614D*B002
T8.380 SmartTrax™ PST TIER 4B [ZJRE04001 -]	Middle East Africa	F2CFE614D*B002
T8.380 SmartTrax™ PST TIER 4B [ZJRE04001 -]	Latin America	F2CFE614D*B002
T8.410 SmartTrax™ PST TIER 4B [ZJRE04001 -]	North America	F2CFE614C*B002
T8.410 SmartTrax™ PST TIER 4B [ZJRE04001 -]	Australia New Zealand	F2CFE614C*B002
T8.410 SmartTrax™ PST TIER 4B [ZJRE04001 -]	Latin America	F2CFE614C*B002
T8.410 SmartTrax™ PST TIER 4B [ZJRE04001 -]	Middle East Africa	F2CFE614C*B002

<https://www.ebooklibonline.com>

Hello dear friend!

Thank you very much for reading.

Enter the link into your browser.

The full manual is available for immediate download.

<https://www.ebooklibonline.com>

Contents

INTRODUCTION

Engine	10
[10.001] Engine and crankcase	10.1
[10.101] Cylinder heads	10.2
[10.202] Air cleaners and lines	10.3
[10.206] Fuel filters	10.4
[10.216] Fuel tanks	10.5
[10.218] Fuel injection system.....	10.6
[10.304] Engine lubrication system.....	10.7
[10.310] Aftercooler.....	10.8
[10.400] Engine cooling system	10.9
[10.414] Fan and drive	10.10
[10.500] Selective Catalytic Reduction (SCR) exhaust treatment.....	10.11
Power coupling	19
[19.100] Drive shaft.....	19.1
[19.110] Flywheel damper	19.2
[19.120] Drive shaft shield assembly	19.3
Transmission	21
[21.105] Powershift transmission hydraulic components	21.1
[21.113] Powershift transmission	21.2
[21.135] Powershift transmission external controls.....	21.3
[21.155] Powershift transmission internal components.....	21.4
[21.200] Dropbox	21.5
Four-Wheel Drive (4WD) system	23
[23.202] Electro-hydraulic control	23.1
[23.314] Drive shaft.....	23.2

Front axle system	25
[25.100] Powered front axle	25.1
[25.102] Front bevel gear set and differential	25.2
[25.108] Final drive hub, steering knuckles, and shafts	25.3
[25.122] Axle suspension control	25.4
Rear axle system.....	27
[27.100] Powered rear axle.....	27.1
[27.106] Rear bevel gear set and differential.....	27.2
[27.120] Planetary and final drives	27.3
[27.610] Rear axle track yoke assembly	27.4
Power Take-Off (PTO).....	31
[31.104] Rear electro-hydraulic control.....	31.1
[31.110] One-speed rear Power Take-Off (PTO)	31.2
[31.114] Two-speed rear Power Take-Off (PTO)	31.3
[31.146] Front Power Take-Off (PTO)	31.4
Brakes and controls	33
[33.110] Parking brake or parking lock	33.1
[33.202] Hydraulic service brakes	33.2
[33.220] Trailer brake hydraulic control.....	33.3
[33.224] Trailer brake pneumatic control	33.4
Hydraulic systems.....	35
[35.000] Hydraulic systems.....	35.1
[35.102] Pump control valves.....	35.2
[35.106] Variable displacement pump	35.3
[35.114] Three-point hitch control valve	35.4
[35.124] Three-point hitch hydraulic adjustment	35.5
[35.204] Remote control valves	35.6
[35.300] Reservoir, cooler, and filters.....	35.7

[35.304] Combination pump units	35.8
Hitches, drawbars, and implement couplings.....	37
[37.110] Rear three-point hitch	37.1
[37.120] Rear three-point hitch linkage	37.2
[37.162] Front hitch	37.3
Frames and ballasting	39
[39.100] Frame	39.1
Steering.....	41
[41.101] Steering control	41.1
[41.200] Hydraulic control components.....	41.2
[41.206] Pump	41.3
[41.432] Autoguidance steering	41.4
Wheels	44
[44.520] Rear wheels	44.1
Tracks and track suspension	48
[48.100] Tracks	48.1
[48.130] Track frame and driving wheels.....	48.2
[48.134] Track tension units	48.3
[48.138] Track rollers	48.4
Cab climate control	50
[50.100] Heating	50.1
[50.200] Air conditioning.....	50.2
[50.300] Cab pressurizing system	50.3
Electrical systems	55
[55.000] Electrical system	55.1
[55.010] Fuel injection system.....	55.2
[55.012] Engine cooling system	55.3

[55.013] Engine oil system	55.4
[55.014] Engine intake and exhaust system.....	55.5
[55.015] Engine control system.....	55.6
[55.024] Transmission control system	55.7
[55.045] Front axle control system	55.8
[55.046] Rear axle control system.....	55.9
[55.047] Steering control system	55.10
[55.050] Heating, Ventilation, and Air-Conditioning (HVAC) control system.....	55.11
[55.051] Cab Heating, Ventilation, and Air-Conditioning (HVAC) controls.....	55.12
[55.100] Harnesses and connectors.....	55.13
[55.130] Rear three-point hitch electronic control system	55.14
[55.201] Engine starting system.....	55.15
[55.301] Alternator.....	55.16
[55.302] Battery.....	55.17
[55.408] Warning indicators, alarms, and instruments	55.18
[55.510] Cab or platform harnesses and connectors.....	55.19
[55.512] Cab controls.....	55.20
[55.513] Cab transmission controls.....	55.21
[55.518] Wiper and washer system.....	55.22
[55.640] Electronic modules	55.23
[55.988] Selective Catalytic Reduction (SCR) electrical system	55.24
[55.DTC] FAULT CODES.....	55.25

Platform, cab, bodywork, and decals 90

[90.100] Engine hood and panels	90.1
[90.102] Engine shields, hood latches, and trims	90.2
[90.124] Pneumatically-adjusted operator seat.....	90.3
[90.150] Cab.....	90.4
[90.151] Cab interior.....	90.5

[90.160] Cab interior trim and panels..... 90.6



INTRODUCTION

Foreword - Important notice regarding equipment servicing

All repair and maintenance work listed in this manual must be carried out only by qualified dealership personnel, strictly complying with the instructions given, and using, whenever possible, the special tools.

Anyone who performs repair and maintenance operations without complying with the procedures provided herein shall be responsible for any subsequent damages.

The manufacturer and all the organizations of its distribution chain, including - without limitation - national, regional, or local dealers, reject any responsibility for damages caused by parts and/or components not approved by the manufacturer, including those used for the servicing or repair of the product manufactured or marketed by the manufacturer. In any case, no warranty is given or attributed on the product manufactured or marketed by the manufacturer in case of damages caused by parts and/or components not approved by the manufacturer.

The manufacturer reserves the right to make improvements in design and changes in specifications at any time without notice and without incurring any obligation to install them on units previously sold. Specifications, descriptions, and illustrative material herein are as accurate as known at time of publication but are subject to change without notice.

In case of questions, refer to your NEW HOLLAND Sales and Service Networks.

Safety rules

Personal safety





This is the safety alert symbol. It is used to alert you to potential personal injury hazards. Obey all safety messages that follow this symbol to avoid possible death or injury.

Throughout this manual you will find the signal words DANGER, WARNING, and CAUTION followed by special instructions. These precautions are intended for the personal safety of you and those working with you.

Read and understand all the safety messages in this manual before you operate or service the machine.

 DANGER indicates a hazardous situation that, if not avoided, will result in death or serious injury.

 WARNING indicates a hazardous situation that, if not avoided, could result in death or serious injury.

 CAUTION indicates a hazardous situation that, if not avoided, could result in minor or moderate injury.

FAILURE TO FOLLOW DANGER, WARNING, AND CAUTION MESSAGES COULD RESULT IN DEATH OR SERIOUS INJURY.

Machine safety

NOTICE: Notice indicates a situation that, if not avoided, could result in machine or property damage.

Throughout this manual you will find the signal word Notice followed by special instructions to prevent machine or property damage. The word Notice is used to address practices not related to personal safety.

Information

NOTE: Note indicates additional information that clarifies steps, procedures, or other information in this manual.

Throughout this manual you will find the word Note followed by additional information about a step, procedure, or other information in the manual. The word Note is not intended to address personal safety or property damage.

Safety rules - General maintenance safety

General maintenance safety

Keep the area used for servicing the machine clean and dry. Clean up spilled fluids.

Service the machine on a firm, level surface.

Install guards and shields after you service the machine.

Close all access doors and install all panels after servicing the machine.

Do not attempt to clean, lubricate, clear obstructions, or make adjustments to the machine while it is in motion or while the engine is running.

Always make sure that working area is clear of tools, parts, other persons and pets before you start operating the machine.

Unsupported hydraulic cylinders can lose pressure and drop the equipment, causing a crushing hazard. Do not leave equipment in a raised position while parked or during service, unless the equipment is securely supported.

Jack or lift the machine only at jack or lift points indicated in this manual.

Incorrect towing procedures can cause accidents. When you tow a disabled machine follow the procedure in this manual. Use only rigid tow bars.

Stop the engine, remove the key, and relieve pressure before you connect or disconnect fluid lines.

Stop the engine and remove the key before you connect or disconnect electrical connections.

Scalding can result from incorrect removal of coolant caps. Cooling systems operate under pressure. Hot coolant can spray out if you remove a cap while the system is hot. Allow the system to cool before you remove the cap. When you remove the cap, turn it slowly to allow pressure to escape before you completely remove the cap.

Replace damaged or worn tubes, hoses, electrical wiring, etc.

The engine, transmission, exhaust components, and hydraulic lines may become hot during operation. Take care when you service such components. Allow surfaces to cool before you handle or disconnect hot components. Wear protective equipment when appropriate.

When welding, follow the instructions in the manual. Always disconnect the battery before you weld on the machine. Always wash your hands after you handle battery components.

Product identification - Machine orientation

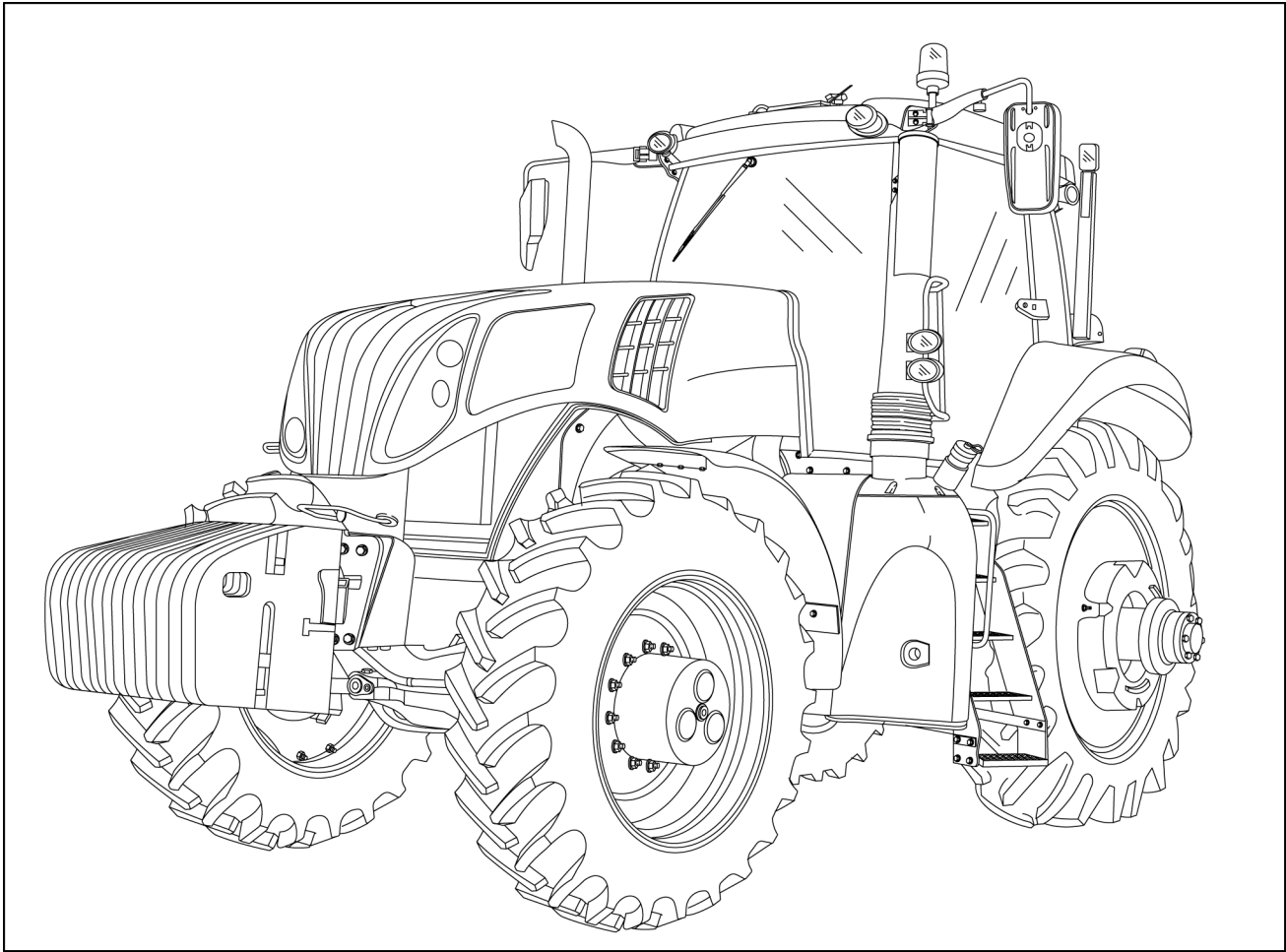

RAIL14TR02056GA 1

The right hand and left hand side of the tractor used in this manual are the same as your right hand and left hand when sitting in the tractor seat looking forward.



SERVICE MANUAL

Engine

T8.320 PST TIER 4B [ZJRE04001 -], T8.350 PST TIER 4B [ZJRE04001 -], T8.380 PST TIER 4B [ZJRE04001 -], T8.380 SmartTrax™ PST TIER 4B [ZJRE04001 -], T8.410 PST TIER 4B [ZJRE04001 -], T8.410 SmartTrax™ PST TIER 4B [ZJRE04001 -]

Visual external differences for T8. tractor engines

There are a few things that make the FPT **Cursor® 9** engine used in the T8. tractors visually and mechanically different from other **Cursor® 9** applications.

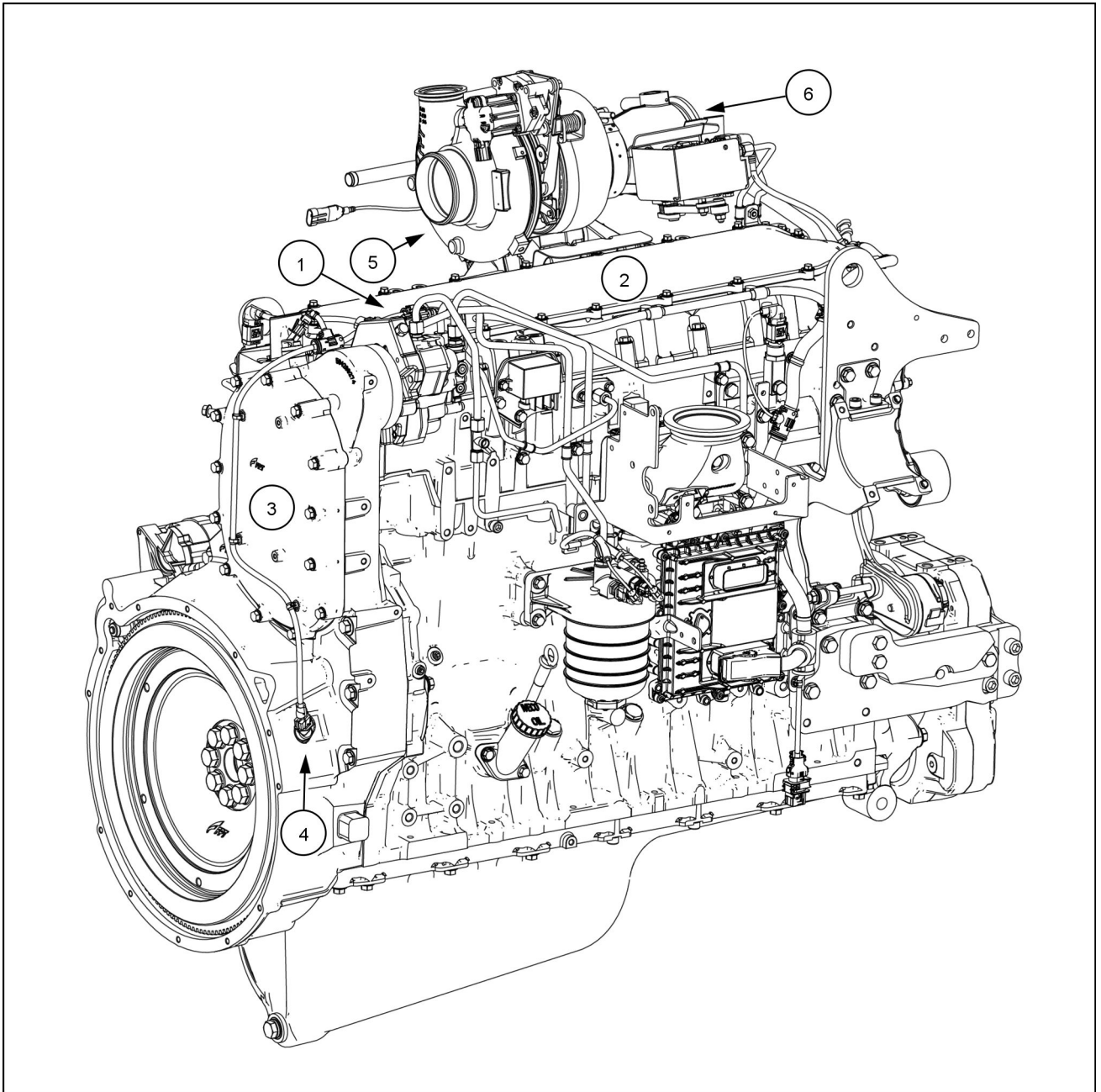

RAIL15TR00608GA 3

1. The fuel pump sits higher and closet to the center line of the engine.
2. A two piece valve cover assembly that allows for valve adjustment without removing the entire cover.
3. The rear cover is an oval shape where on other **Cursor® 9** engines it's round.
4. The flywheel speed sensor is located on the right side of the engine, others have on the left side of the engine.
5. The turbocharger is moved higher and toward the center line of the engine.
6. Exhaust flap for TIER 4B.

Exhaust brake

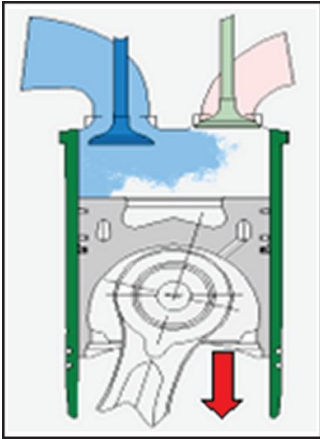

Admission phase:
Intake of fresh air.

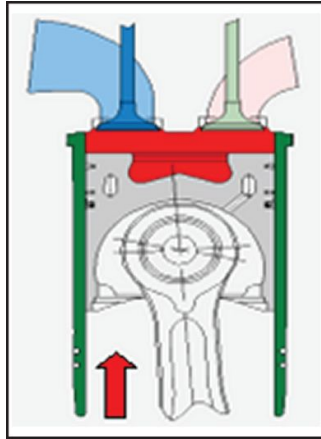

Compression phase:
Energy is stored in the compressed air, braking effect increases with compression

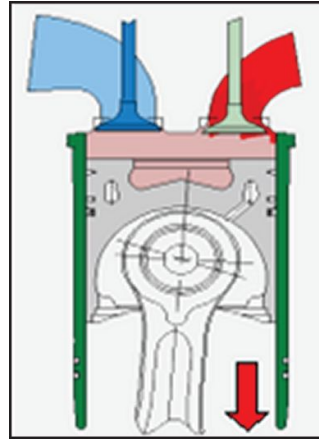

Top dead center:
Exhaust valves open, compressed air is released, energy is blown out.

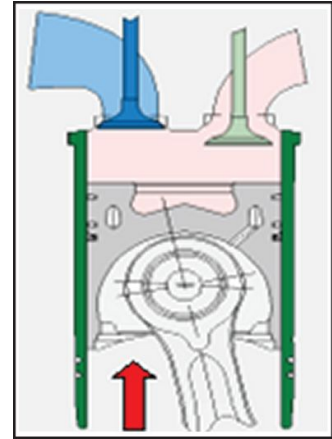

Exhaust phase:
Cylinder is empty, no energy exchange. Exhaust gases impact against the turbine, creating an additional braking effect.

All **Cursor®** engines are equipped with an advanced engine brake system: the Iveco Turbo Brake (IBT) system.

- Decompression engine brake
- Quick responding
- Integrated in the engine control
- Linked to cruise control
- Linked to EBS

Advantage

- Less brake pad wear
- Automatically engaged

Benefit

- Reduced operation cost
- Operator ease

The engine brake is controlled by the Tractor Control Unit (TCU). The Electronic Service Tool (EST) is used to configure the TCU as to whether or not the tractor has an engine brake.

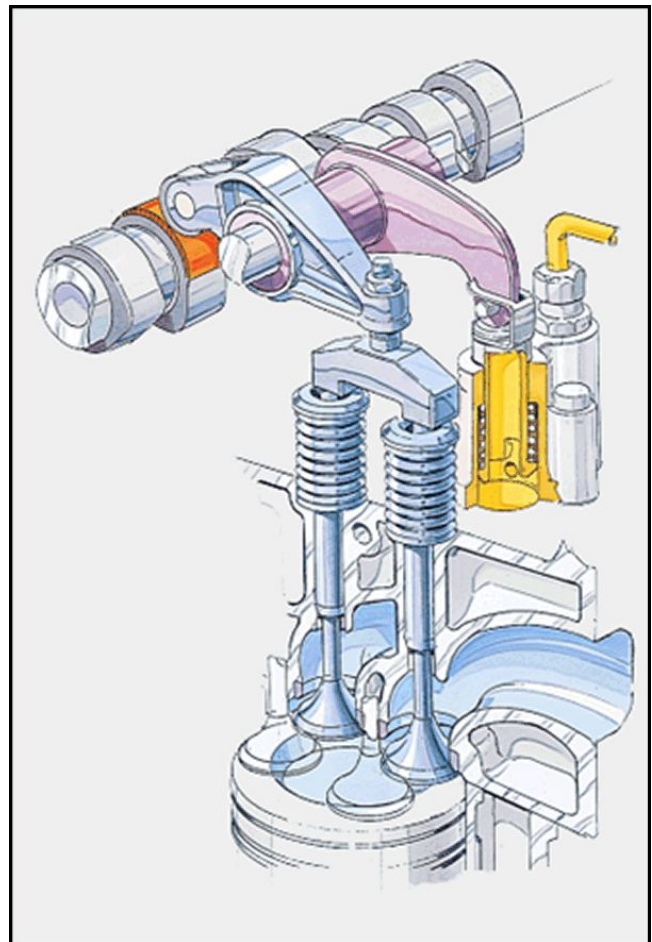



Suggest:

If the above button click is invalid.

Please download this document

first, and then click the above link

to download the complete manual.

Thank you so much for reading

The engine brake is activated when the pedal left of the clutch is depressed.

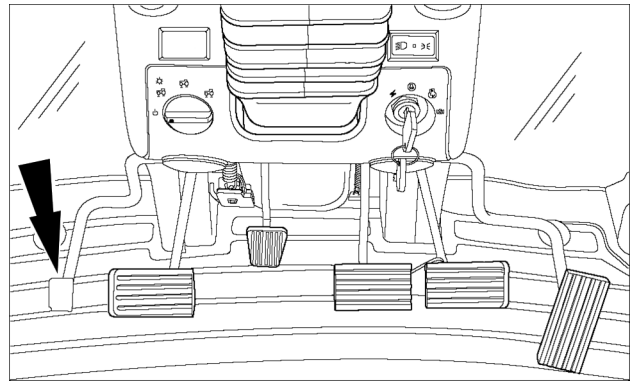

RCPH11CCH481AAA 4

Air Induction - cross flow cylinder head

The cylinder head is of the cross flow design, inlet on one side and exhaust on the other. This and four valves per cylinder give it excellent breathing ability and efficient temperature control. The air is supplied to the inlet by a wastegate turbocharger or a Variable Geometry Turbocharger (VGT).

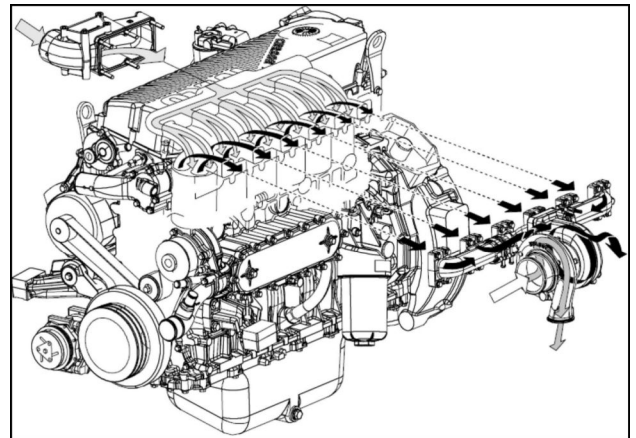

RAIL15TR00376BA 5

Wastegate turbocharger

The wastegate turbocharger allows for a larger turbocharger to be installed producing higher boost pressures in the low and midrange rpm while not over-boosting at high rpm.

Intake pressure builds against a diaphragm in the wastegate and opens a valve allowing exhaust to bypass the turbine therefore slowing the compressor and limiting the pressure in the intake manifold.

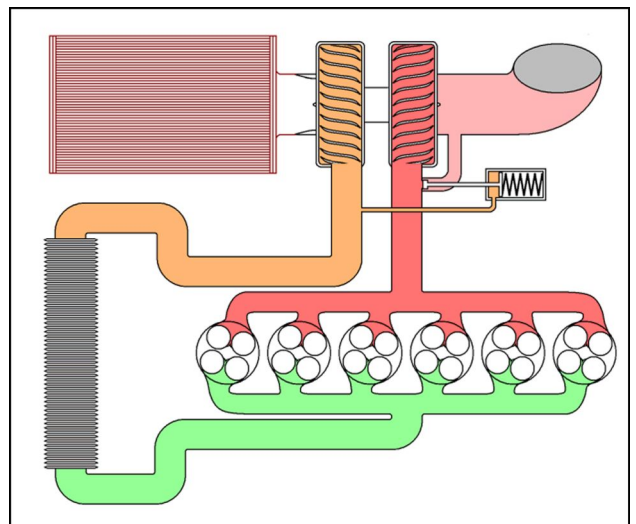

RAIL15TR00396BA 6

<https://www.ebooklibonline.com>

Hello dear friend!

Thank you very much for reading.

Enter the link into your browser.

The full manual is available for immediate download.

<https://www.ebooklibonline.com>