

# SERVICE MANUAL

## **FR480 Forage Cruiser / FR550 Forage Cruiser / FR650 Forage Cruiser / FR780 Forage Cruiser Tier 4B (final) Forage Harvester**

*FR480 Forage Cruiser - From PIN 715912001 to 715923100*

*FR550 Forage Cruiser - From PIN 725912001 to 725923100*

*FR650 Forage Cruiser - From PIN 735912001 to 735923100*

*FR780 Forage Cruiser - From PIN 745912001 to 745923100*

## **FR850 Forage Cruiser Tier 2 Forage Harvester**

*FR850 Forage Cruiser - From PIN 555912001 to 555923100*

**Part number 48142788**

English  
April 2017





## **SERVICE MANUAL**

**FR480 Forage Cruiser Cursor 13, TIER 4B (FINAL) [715912001 - 715923100]**

**FR550 Forage Cruiser Cursor 13, TIER 4B [725912001 - 725923100]**

**FR650 Forage Cruiser Cursor 16, TIER 4B (FINAL) [735912001 - 735923100]**

**FR780 Forage Cruiser Cursor 16, TIER 4B (FINAL) [745912001 - 745923100]**

**FR850 Forage Cruiser Vector, TIER2 [555912001 - 555923100]**

## Link Product / Engine

---

<b>Product</b>	<b>Market Product</b>	<b>Engine</b>
FR480 Forage Cruiser Cursor 13, TIER 4B (FINAL) [715912001 - 715923100]	North America	F3HFE613H*B007
FR550 Forage Cruiser Cursor 13, TIER 4B [725912001 - 725923100]	North America	F3H FE613F*B007
FR650 Forage Cruiser Cursor 16, TIER 4B (FINAL) [735912001 - 735923100]	North America	F3JFE613A*B005
FR780 Forage Cruiser Cursor 16, TIER 4B (FINAL) [745912001 - 745923100]	North America	F3JFE613B*B006
FR850 Forage Cruiser Vector, TIER2 [555912001 - 555923100]	North America	FVAE2884X*B200

**<https://www.ebooklibonline.com>**

Hello dear friend!

Thank you very much for reading.

Enter the link into your browser.

The full manual is available for immediate download.

**<https://www.ebooklibonline.com>**

# Contents

---

## INTRODUCTION

<b>Engine</b> .....	<b>10</b>
[10.001] Engine and crankcase .....	10.1
[10.216] Fuel tanks .....	10.2
[10.218] Fuel injection system.....	10.3
[10.400] Engine cooling system .....	10.4
[10.414] Fan and drive .....	10.5
[10.418] Rotary screen .....	10.6
[10.304] Engine lubrication system.....	10.7
[10.500] Selective Catalytic Reduction (SCR) exhaust treatment.....	10.8
<b>Main gearbox and drive</b> .....	<b>14</b>
[14.100] Main gearbox and drive .....	14.1
<b>Transmission</b> .....	<b>21</b>
[21.114] Mechanical transmission .....	21.1
[21.120] Gearbox.....	21.2
[21.130] Mechanical transmission external controls.....	21.3
[21.100] Mechanical transmission lubrication system .....	21.4
[21.145] Gearbox internal components.....	21.5
[21.182] Differential.....	21.6
<b>Four-Wheel Drive (4WD) system</b> .....	<b>23</b>
[23.101] Mechanical control .....	23.1
[23.304] Four-Wheel Drive (4WD) gearbox .....	23.2
<b>Front axle system</b> .....	<b>25</b>
[25.100] Powered front axle .....	25.1
[25.102] Front bevel gear set and differential .....	25.2
[25.310] Final drives .....	25.3

<b>Rear axle system</b> .....	<b>27</b>
[27.450] Rear-powered steerable axle .....	27.1
[27.550] Non-powered rear axle.....	27.2
<b>Hydrostatic drive</b> .....	<b>29</b>
[29.218] Pump and motor components.....	29.1
[29.202] Hydrostatic transmission .....	29.2
<b>Brakes and controls</b> .....	<b>33</b>
[33.202] Hydraulic service brakes .....	33.1
[33.110] Parking brake or parking lock .....	33.2
<b>Hydraulic systems</b> .....	<b>35</b>
[35.000] Hydraulic systems.....	35.1
[35.529] Spout.....	35.2
[35.102] Pump control valves.....	35.3
[35.106] Variable displacement pump .....	35.4
[35.204] Remote control valves .....	35.5
[35.300] Reservoir, cooler, and filters.....	35.6
[35.359] Main control valve.....	35.7
[35.350] Safety and main relief valves .....	35.8
[35.600] High flow hydraulics.....	35.9
[35.410] Header or attachment height system .....	35.10
[35.602] Header or attachment leveling system .....	35.11
[35.514] Upper feed roll gearbox system.....	35.12
[35.516] Sharpening system.....	35.13
[35.530] Spout rotation circuit .....	35.14
[35.532] Spout raising system .....	35.15
[35.534] Spout deflector system.....	35.16
[35.860] Main gearbox lubrication .....	35.17
<b>Steering</b> .....	<b>41</b>

[41.101] Steering control .....	41.1
[41.206] Pump .....	41.2
[41.216] Cylinders .....	41.3
[41.432] Autoguidance steering .....	41.4
<b>Wheels .....</b>	<b>44</b>
[44.511] Front wheels .....	44.1
[44.520] Rear wheels .....	44.2
<b>Cab climate control .....</b>	<b>50</b>
[50.100] Heating .....	50.1
[50.200] Air conditioning .....	50.2
<b>Electrical systems .....</b>	<b>55</b>
[55.000] Electrical system .....	55.1
[55.100] Harnesses and connectors .....	55.2
[55.015] Engine control system .....	55.3
[55.010] Fuel injection system .....	55.4
[55.014] Engine intake and exhaust system .....	55.5
[55.988] Selective Catalytic Reduction (SCR) electrical system .....	55.6
[55.012] Engine cooling system .....	55.7
[55.013] Engine oil system .....	55.8
[55.301] Alternator .....	55.9
[55.426] Harvest material flow control system .....	55.10
[55.512] Cab controls .....	55.11
[55.640] Electronic modules .....	55.12
[55.610] Ground speed control .....	55.13
[55.019] Hydrostatic drive control system .....	55.14
[55.051] Cab Heating, Ventilation, and Air-Conditioning (HVAC) controls .....	55.15
[55.050] Heating, Ventilation, and Air-Conditioning (HVAC) control system .....	55.16
[55.421] Feeding control system .....	55.17

[55.820] Chopping and cutting control systems .....	55.18
[55.830] Rotary screen drive and cleaning .....	55.19
[55.680] Autopilot/Autoguidance .....	55.20
[55.450] Ejecting control system .....	55.21
[55.408] Warning indicators, alarms, and instruments .....	55.22
[55.637] Silage additives system control .....	55.23
[55.DTC] FAULT CODES .....	55.24
<b>Attachments/Headers .....</b>	<b>58</b>
[58.130] Attachment/Header frame .....	58.1
[58.900] Belt feeding .....	58.2
<b>Product feeding .....</b>	<b>60</b>
[60.101] Feed roll .....	60.1
[60.122] Length-of-cut gearbox .....	60.2
[60.103] Lower feed rolls .....	60.3
[60.107] Upper feed rolls .....	60.4
<b>Chemical applicators .....</b>	<b>63</b>
[63.115] Silage additives system .....	63.1
<b>Chopping .....</b>	<b>64</b>
[64.100] Cutterhead .....	64.1
[64.106] Drum .....	64.2
[64.130] Drum gearbox .....	64.3
[64.140] Sharpening system .....	64.4
[64.150] Shearbar .....	64.5
[64.160] Crop processor .....	64.6
[64.170] Transition channel/concave and lever .....	64.7
<b>Ejection .....</b>	<b>70</b>
[70.120] Blower .....	70.1
[70.140] Spout .....	70.2

Lubrication system.....	71
[71.460] Grease lubrication system .....	71.1
Platform, cab, bodywork, and decals.....	90
[90.105] Machine shields and guards .....	90.1
[90.150] Cab.....	90.2
[90.151] Cab interior.....	90.3



# INTRODUCTION

## Safety rules

FR480 Forage Cruiser	NA
FR550 Forage Cruiser	NA
FR650 Forage Cruiser	NA
FR780 Forage Cruiser	NA
FR850 Forage Cruiser	NA

## LEGAL OBLIGATIONS

This machine may be equipped with special guarding or other devices in compliance with local legislation. Some of these require active use by the operator. Therefore, check local legislations on the usage of this machine.

## ACCIDENT PREVENTION

Most accidents or injuries that occur in workshops are the result of non compliance to simple and fundamental safety principles. For this reason, IN MOST CASES THESE ACCIDENTS CAN BE AVOIDED by applying the fundamental safety principles, acting with the necessary caution and care.

Accidents may occur with all types of machine, regardless of how well the machine in question was designed and built.

### CAUTION

#### Unexpected machine movement!

1. Disengage all drives.
  2. Engage parking brake.
  3. Lower all attachments to the ground, or raise and engage all safety locks.
  4. Shut off engine.
  5. Remove key from key switch.
  6. Switch off battery key, if installed.
  7. Wait for all machine movement to stop.
- Failure to comply could result in minor or moderate injury.

C0038A

## SAFETY REQUIREMENTS FOR FLUID POWER SYSTEMS AND COMPONENTS - HYDRAULICS

- Flexible hose assemblies must not be constructed from hoses which have been previously used as part of a hose assembly.
- Do not weld hydraulic pipes: when flexible hoses or piping are damaged, replace them immediately.
- It is forbidden to modify a hydraulic accumulator by machining, welding or any other way.
- Before removing hydraulic accumulators for servicing, the liquid pressure in the accumulators must be reduced to zero.
- Pressure check on hydraulic accumulators must be carried out by a method recommended by the accumulator manufacturer.
- Take care not to exceed the maximum allowed pressure of the accumulator. After any check or adjustment, check for leakages or gas in the hoses or tubes.

## SAFETY RULES

### General guidelines

- Carefully follow specified repair and maintenance procedures.
- When appropriate, use P.P.E (Personal Protective Equipment)
- Do not wear rings, wristwatches, jewellery, unbuttoned or loose articles of clothing such as: ties, torn clothing, scarves, open jackets or shirts with open zips that may remain entangled in moving parts. It is advised to wear approved safety clothing, e.g.: non-slip footwear, gloves, safety goggles, helmets, etc.

## INTRODUCTION

---

- Do not carry out repair operations with someone sitting in the driver's seat, unless the person is a trained technician who is assisting with the operation in question.
- Do not operate the machine or use any of the implements from different positions, other than the driver's seat.
- Do not carry out operations on the machine with the engine running, unless specifically indicated.
- Bring all hydraulic cylinders to the home positions (down, retracted, etc.) before engine shut down.
- Stop the engine and check that the hydraulic circuits are pressure-free before removing caps, covers, valves, etc.
- All repair and maintenance operations must be carried out using extreme care and attention.
- Service steps and platforms used in the workshop or elsewhere should be built according to the applicable standards and legislation.
- Disconnect the Power Take-Off (PTO) and label the controls to indicate that the machine is being serviced.
- Brakes are inoperative when manually released for repair or maintenance purposes. Use blocks or similar devices to secure the machine in these conditions.
- Only use specified towing points for towing the machine. Connect parts carefully. Make sure that all pins and/or locks are secured in position before applying traction. Never remain near the towing bars, cables or chains that are operating under load.
- When loading or unloading the machine from the trailer (or other means of transport), select a flat area capable of sustaining the trailer or truck wheels. Firmly secure the machine to the truck or trailer and lock the wheels in the position used by the carrier.
- Electric heaters, battery-chargers and similar equipment must only be powered by auxiliary power supplies with efficient ground insulation to avoid electrical shock hazards.
- Always use suitable hoisting or lifting devices when raising or moving heavy parts.
- Keep bystanders away.
- Never use gasoline, diesel oil or other inflammable liquids as cleaning agents. Use non-inflammable, non toxic commercially available solvents.
- Wear safety goggles with side guards when cleaning parts with compressed air.
- Never use open flames for lighting when working on the machine or checking for leaks.
- When carrying out checks with the engine running, request the assistance of an operator in the driver's seat. The operator must maintain visual contact with the service technician at all times.
- If operating outside the workshop, position the machine on a flat surface and lock in position. If working on a slope, lock the machine in position. Move to a flat area as soon as is safely possible.
- Maintenance and repair operations must be carried out in a clean and dry area. Clean up any water or oil spillage immediately.
- Do not create piles of oil or grease-soaked rags as they represent a serious fire hazard. Always store rags in a closed metal container.
- Before engaging the machine, make sure that there are no persons within the machine or implement range of action.
- Empty your pockets of all objects that may fall accidentally unobserved into the machine inner compartments.
- When metal parts are sticking out, use protective goggles or goggles with side guards, helmets, special footwear and gloves.
- When welding, use protective safety devices: tinted safety goggles, helmets, special overalls, gloves and footwear. All persons present in the area where welding is taking place must wear tinted goggles. **NEVER LOOK DIRECTLY AT THE WELDING ARC WITHOUT SUITABLE EYE PROTECTION.**

### Machine start-up.

- Never run the engine in confined spaces that are not equipped with adequate ventilation for exhaust gas extraction.
- Never place the head, body, limbs, feet, hands or fingers near rotating and moving parts.

### Hydraulic systems and fuel injection systems

- A liquid leaking from a tiny hole may be almost invisible but, at the same time, be powerful enough to penetrate the skin. Therefore, NEVER USE HANDS TO CHECK FOR LEAKS but use a piece of cardboard or paper for this purpose. If any liquid penetrates skin tissue, call for medical aid immediately. Failure to treat this condition with correct medical procedure may result in serious infection or death.
- In order to check the pressure in the system use suitable instruments.

### Wheels and tires

- Make sure that the tires are correctly inflated at the pressure specified by the manufacturer. Periodically check the rims and tires for damage.
- Stand away from (at the side of) the tire when checking inflation pressure.
- Do not use parts of recovered wheels as incorrect welding brazing or heating may weaken and eventually cause damage to the wheel.
- Never cut or weld a rim mounted with an inflated tire.
- Deflate the tire before removing any objects that may be jammed in the tire tread.
- Never inflate tires using inflammable gases, as this may result in explosions and injury to bystanders.

### Removal and installation

- Lift and handle all heavy parts using suitable hoisting equipment. Make sure that parts are sustained by appropriate hooks and slings. Use the hoisting eyebolts for lifting operations. Extra care should be taken if persons are present near the load to be lifted.
- Handle all parts carefully. Do not put your hands or fingers between parts. Wear suitable safety clothing - safety goggles, gloves and shoes.
- Avoid twisting chains or metal cables. Always wear safety gloves when handling cables or chains.
- Damaged or bent chains or cables are unreliable. Do not use them for lifting or towing. Always use suitable protective gloves when handling chains or cables.
- Chains should always be safely secured. Make sure that the hitch-up point is capable of sustaining the load in question. Keep the area near the hitch-up point, chains or cables free of all bystanders.
- Metal cables tend to fray with repeated use. Always use suitable protective devices (gloves, goggles, etc.) when handling cables.



# **SERVICE MANUAL**

## **Engine**

- FR480 Forage Cruiser Cursor 13, TIER 4B (FINAL) [715912001 - 715923100]**
- FR550 Forage Cruiser Cursor 13, TIER 4B [725912001 - 725923100]**
- FR650 Forage Cruiser Cursor 16, TIER 4B (FINAL) [735912001 - 735923100]**
- FR780 Forage Cruiser Cursor 16, TIER 4B (FINAL) [745912001 - 745923100]**
- FR850 Forage Cruiser Vector, TIER2 [555912001 - 555923100]**

## Engine - Remove

FR480 Forage Cruiser	NA
FR550 Forage Cruiser	NA
FR650 Forage Cruiser	NA
FR780 Forage Cruiser	NA

### **⚠ DANGER**

**Heavy objects!**

**Lift and handle all heavy components using lifting equipment with adequate capacity. Always support units or parts with suitable slings or hooks. Make sure the work area is clear of all bystanders.**

**Failure to comply will result in death or serious injury.**

D0926A

### **⚠ WARNING**

**Fall hazard!**

**Use a sturdy platform when working above ground level.**

**Failure to comply could result in death or serious injury.**

W0926A

### **⚠ WARNING**

**Jack stands can slip or fall over. Dropping, tipping, or slipping of machine or its components is possible.**

**DO NOT work under a vehicle supported by jack stands only. Park machine on a level surface. Block wheels. Support machine with safety stands.**

**Failure to comply could result in death or serious injury.**

W0069A

**NOTE:** The engine removal is done on FR480 but the instructions and figures can be used as a guideline for all other models, except for the FR850.

**NOTE:** When disconnecting fluid lines, have a suitable container available to collect any residual fluids. Use stops and/or plugs to prevent fluids spill and to protect against dirt ingress.

## Shieldings

1. Move the spout to the extreme left or right.
2. Remove both the side shieldings. See **Side shields - Remove (90.105)**.
3. Remove the rear fenders.
4. For better access remove the steering wheels. See **Rear wheel - Remove (44.520)**.

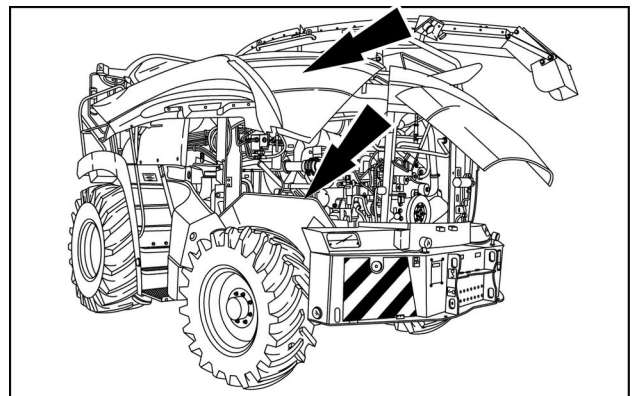

ZEIL15FR00087AA 1

5. Remove the rear shield.

- Support the rear shield **(2)**. Ask the assistance of a second person or use a suitable lifting device.
- Lift up the bottom clip from the gas strut **(3)**, then remove the gas strut **(3)** from the pivot bolt.
- Remove the hardware **(1)**.
- Remove the rear shield **(2)**.

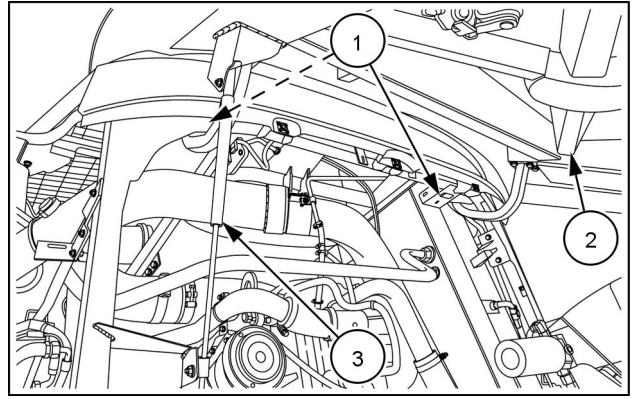

ZEIL15FR00085AA 2

6. Remove the hardware **(4)** (six in total) and remove the top rear shield **(5)**.

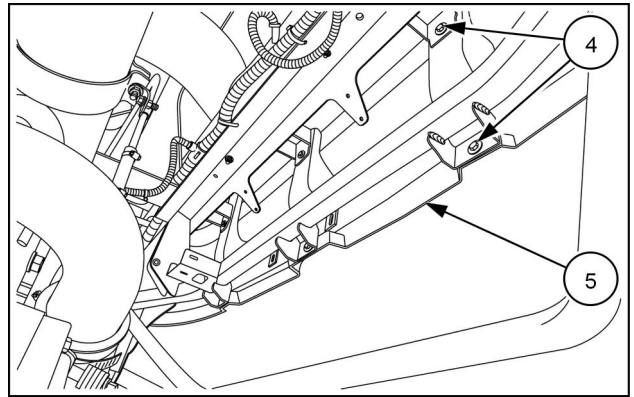

ZEIL15FR00086AA 3

**Discharge the air-conditioning circuit**

7. Discharge the air-conditioning circuit. See chapter "Air Conditioning" in the service manual.

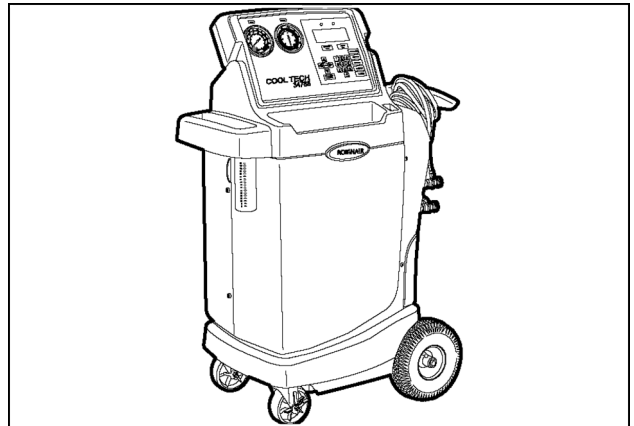

34788-300 4

## Drain Fluids

8. Drain the hydraulic oil reservoir.

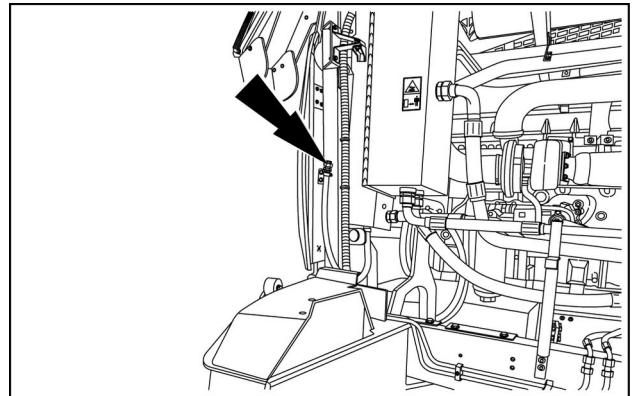

ZEIL15FR00090AA 5

9. Drain the engine coolant:

- Engine coolant radiator

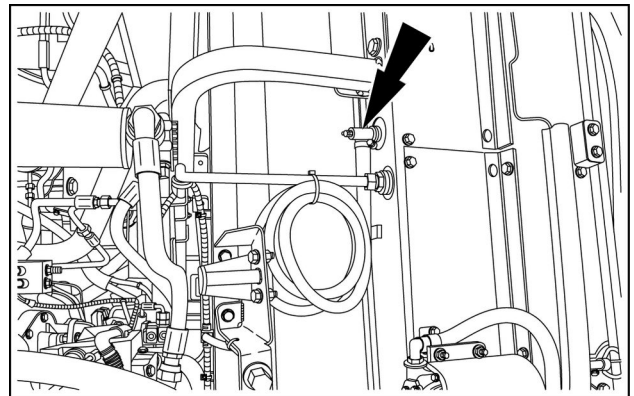

ZEIL15FR00088AA 6

- Engine coolant intake. Close the tap, remove the hose, drain coolant, open the tap and drain fluid.
- Engine coolant outlet. Close the tap, remove the hose, drain coolant, open the tap and drain fluid.

**NOTE:** Still some coolant in the tubes.

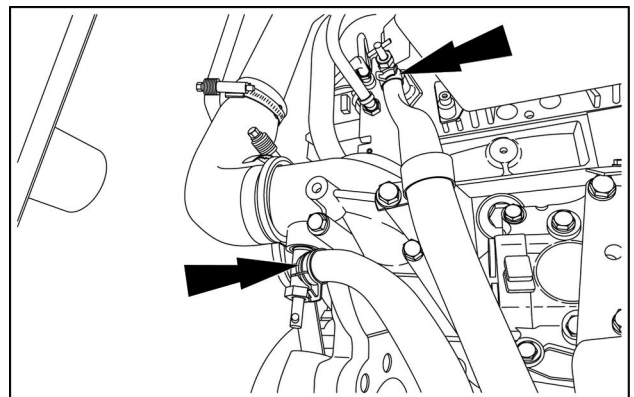

ZEIL15FR00089AA 7

## Wiring harnesses

10. On the left-hand side of the machine, remove all the straps and disconnect all the connectors of the two wiring harness branches (see arrows) going down of the wiring harness (6) and lay the wiring harness branches on top of the roof assembly.

**NOTE:** Remove the air filter clogging sensor and the main gearbox rpm sensor to prevent damage.

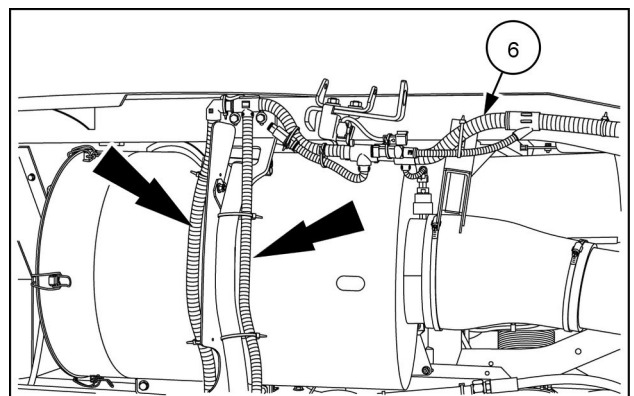

ZEIL15FR00198AA 8



**Suggest:**

**If the above button click is invalid.**

**Please download this document**

**first, and then click the above link**

**to download the complete manual.**

**Thank you so much for reading**

11. Remove all the straps and disconnect all the connectors of the wiring harness branch (see arrow) going down of the wiring harness **(6)** and lay the wiring harness branch on top of the roof assembly. See the location diagram in the service manual.

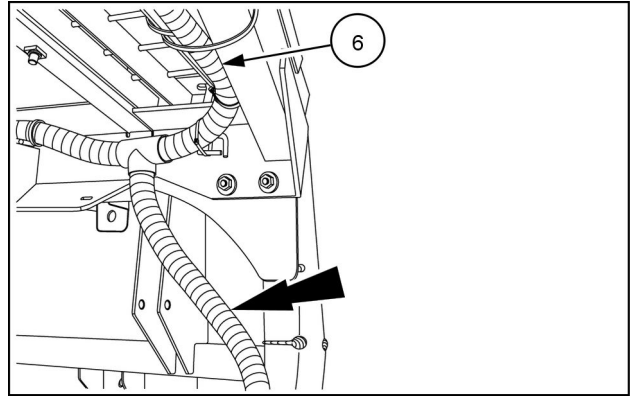

ZEIL15FR00120AA 9

12. On the left hand side of the machine, remove all the straps and disconnect all the connectors of the wiring harness branch (see arrow) going down of the wiring harness **(6)** and lay the wiring harness branch on top of the roof assembly. See the location diagram in the service manual.

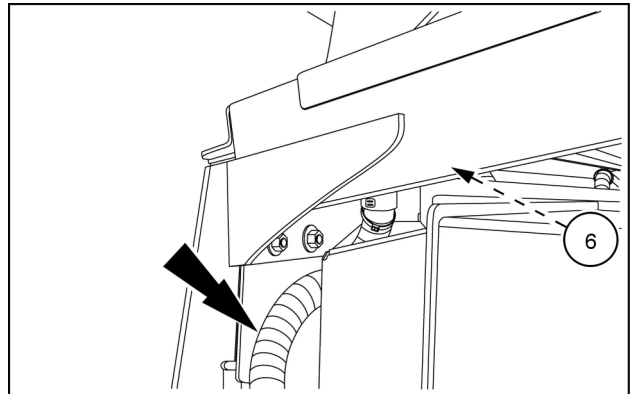

ZEIL15FR00121AA 10

13. On the right-hand side of the machine, disconnect the connector **(7A)**.

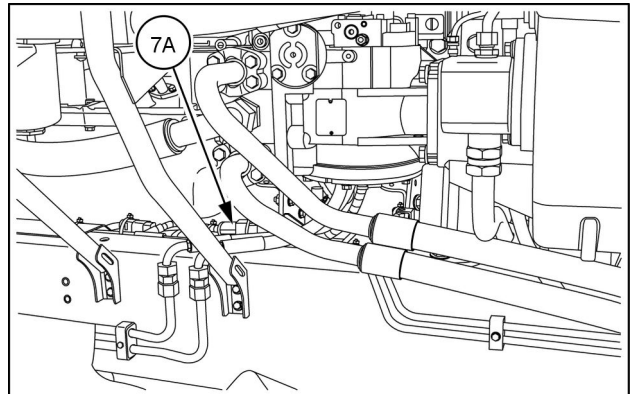

ZEIL15FR00132AA 11

14. Disconnect the ground cable **(8)** from the engine.  
 15. Disconnect the positive lead **(9A)** from the starter motor.

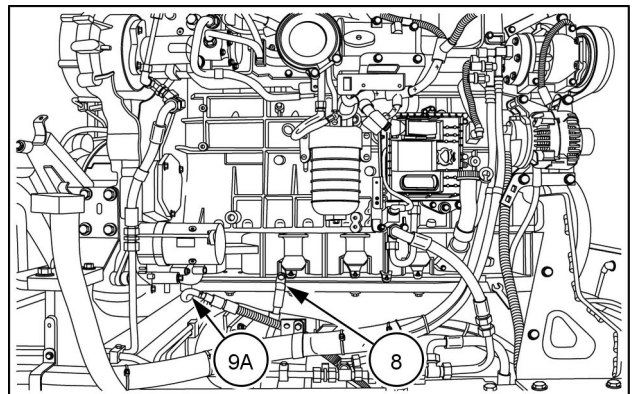

ZEIL15FR00148AA 12

**<https://www.ebooklibonline.com>**

Hello dear friend!

Thank you very much for reading.

Enter the link into your browser.

The full manual is available for immediate download.

**<https://www.ebooklibonline.com>**