

SERVICE MANUAL

**T8.320 / T8.350 / T8.380 / T8.410 / T8.435 /
T8.380 SmartTrax™ / T8.410 SmartTrax™ /
T8.435 SmartTrax™
Continuously Variable Transmission (CVT)
Tractor**

PIN ZFRE05001 and above

Part number 47918010

1st edition English

October 2015





SERVICE MANUAL

T8.320 CVT TIER 2 [ZFRE05001 -], T8.350 CVT TIER 2 [ZFRE05001 -], T8.380 CVT TIER 2 [ZFRE05001 -], T8.380 SmartTrax™ CVT TIER 2 [ZFRE05001 -], T8.410 CVT TIER 2 [ZFRE05001 -], T8.410 SmartTrax™ CVT TIER 2 [ZFRE05001 -], T8.435 CVT TIER 2 [ZFRE05001 -], T8.435 SmartTrax™ CVT TIER 2 [ZFRE05001 -]

Link Product / Engine

Product	Market Product	Engine
T8.320 CVT TIER 2 [ZFRE05001 -]	Australia New Zealand	F2CFA613G*E024
T8.320 CVT TIER 2 [ZFRE05001 -]	North America	F2CFA613G*E024
T8.320 CVT TIER 2 [ZFRE05001 -]	Asia Pacific	F2CFA613G*E024
T8.320 CVT TIER 2 [ZFRE05001 -]	Middle East Africa	F2CFA613G*E024
T8.320 CVT TIER 2 [ZFRE05001 -]	Latin America	F2CFA613G*E024
T8.350 CVT TIER 2 [ZFRE05001 -]	Asia Pacific	F2CFA613D*E024
T8.350 CVT TIER 2 [ZFRE05001 -]	Middle East Africa	F2CFA613D*E024
T8.350 CVT TIER 2 [ZFRE05001 -]	Australia New Zealand	F2CFA613D*E024
T8.350 CVT TIER 2 [ZFRE05001 -]	North America	F2CFA613D*E024
T8.350 CVT TIER 2 [ZFRE05001 -]	Latin America	F2CFA613D*E024
T8.380 CVT TIER 2 [ZFRE05001 -]	Asia Pacific	F2CFA613B*E024
T8.380 CVT TIER 2 [ZFRE05001 -]	Middle East Africa	F2CFA613B*E024
T8.380 CVT TIER 2 [ZFRE05001 -]	Latin America	F2CFA613B*E024
T8.380 CVT TIER 2 [ZFRE05001 -]	Australia New Zealand	F2CFA613B*E024
T8.380 CVT TIER 2 [ZFRE05001 -]	North America	F2CFA613B*E024
T8.410 CVT TIER 2 [ZFRE05001 -]	North America	F2CFA614D*E022
T8.410 CVT TIER 2 [ZFRE05001 -]	Asia Pacific	F2CFA614D*E022
T8.410 CVT TIER 2 [ZFRE05001 -]	Australia New Zealand	F2CFA614D*E022
T8.410 CVT TIER 2 [ZFRE05001 -]	Latin America	F2CFA614D*E022
T8.410 CVT TIER 2 [ZFRE05001 -]	Middle East Africa	F2CFA614D*E022
T8.435 CVT TIER 2 [ZFRE05001 -]	Asia Pacific	F2CFA614A*E022
T8.435 CVT TIER 2 [ZFRE05001 -]	Australia New Zealand	F2CFA614A*E022
T8.435 CVT TIER 2 [ZFRE05001 -]	North America	F2CFA614A*E022
T8.435 CVT TIER 2 [ZFRE05001 -]	Latin America	F2CFA614A*E022

<https://www.ebooklibonline.com>

Hello dear friend!

Thank you very much for reading.

Enter the link into your browser.

The full manual is available for immediate download.

<https://www.ebooklibonline.com>

Product	Market Product	Engine
T8.435 CVT TIER 2 [ZFRE05001 -]	Middle East Africa	F2CFA614A*E022
T8.380 SmartTrax™ CVT TIER 2 [ZFRE05001 -]	Asia Pacific	F2CFA613B*E024
T8.380 SmartTrax™ CVT TIER 2 [ZFRE05001 -]	Middle East Africa	F2CFA613B*E024
T8.380 SmartTrax™ CVT TIER 2 [ZFRE05001 -]	Latin America	F2CFA613B*E024
T8.380 SmartTrax™ CVT TIER 2 [ZFRE05001 -]	Australia New Zealand	F2CFA613B*E024
T8.380 SmartTrax™ CVT TIER 2 [ZFRE05001 -]	North America	F2CFA613B*E024
T8.410 SmartTrax™ CVT TIER 2 [ZFRE05001 -]	Asia Pacific	F2CFA614D*E022
T8.410 SmartTrax™ CVT TIER 2 [ZFRE05001 -]	Latin America	F2CFA614D*E022
T8.410 SmartTrax™ CVT TIER 2 [ZFRE05001 -]	North America	F2CFA614D*E022
T8.410 SmartTrax™ CVT TIER 2 [ZFRE05001 -]	Middle East Africa	F2CFA614D*E022
T8.410 SmartTrax™ CVT TIER 2 [ZFRE05001 -]	Australia New Zealand	F2CFA614D*E022
T8.435 SmartTrax™ CVT TIER 2 [ZFRE05001 -]	Latin America	F2CFA614A*E022
T8.435 SmartTrax™ CVT TIER 2 [ZFRE05001 -]	Asia Pacific	F2CFA614A*E022
T8.435 SmartTrax™ CVT TIER 2 [ZFRE05001 -]	Australia New Zealand	F2CFA614A*E022
T8.435 SmartTrax™ CVT TIER 2 [ZFRE05001 -]	North America	F2CFA614A*E022
T8.435 SmartTrax™ CVT TIER 2 [ZFRE05001 -]	Middle East Africa	F2CFA614A*E022

Contents

INTRODUCTION

Engine.....	10
[10.001] Engine and crankcase	10.1
[10.101] Cylinder heads	10.2
[10.202] Air cleaners and lines	10.3
[10.216] Fuel tanks	10.4
[10.218] Fuel injection system.....	10.5
[10.254] Intake and exhaust manifolds and muffler	10.6
[10.304] Engine lubrication system.....	10.7
[10.310] Aftercooler.....	10.8
[10.400] Engine cooling system	10.9
[10.414] Fan and drive	10.10
Power coupling.....	19
[19.100] Drive shaft.....	19.1
[19.110] Flywheel damper	19.2
[19.120] Drive shaft shield assembly	19.3
Transmission.....	21
[21.504] Continuously Variable Transmission (CVT)	21.1
[21.505] Continuously Variable Transmission (CVT) external controls.....	21.2
[21.506] Continuously Variable Transmission (CVT) lubrication system	21.3
[21.507] Continuously Variable Transmission (CVT) internal components.....	21.4
[21.900] Hydraulic pump drive.....	21.5
Four-Wheel Drive (4WD) system	23
[23.202] Electro-hydraulic control	23.1
[23.314] Drive shaft.....	23.2
Front axle system	25

[25.100] Powered front axle	25.1
[25.102] Front bevel gear set and differential	25.2
[25.108] Final drive hub, steering knuckles, and shafts	25.3
[25.122] Axle suspension control	25.4
Rear axle system	27
[27.100] Powered rear axle	27.1
[27.106] Rear bevel gear set and differential	27.2
[27.120] Planetary and final drives	27.3
[27.610] Rear axle track yoke assembly	27.4
Power Take-Off (PTO)	31
[31.104] Rear electro-hydraulic control	31.1
[31.110] One-speed rear Power Take-Off (PTO)	31.2
[31.114] Two-speed rear Power Take-Off (PTO)	31.3
[31.146] Front Power Take-Off (PTO)	31.4
Brakes and controls	33
[33.110] Parking brake or parking lock	33.1
[33.202] Hydraulic service brakes	33.2
[33.220] Trailer brake hydraulic control	33.3
[33.224] Trailer brake pneumatic control	33.4
Hydraulic systems	35
[35.000] Hydraulic systems	35.1
[35.102] Pump control valves	35.2
[35.106] Variable displacement pump	35.3
[35.114] Three-point hitch control valve	35.4
[35.124] Three-point hitch hydraulic adjustment	35.5
[35.204] Remote control valves	35.6
[35.300] Reservoir, cooler, and filters	35.7
[35.304] Combination pump units	35.8

Hitches, drawbars, and implement couplings.....	37
[37.110] Rear three-point hitch	37.1
[37.162] Front hitch	37.2
Steering.....	41
[41.101] Steering control	41.1
[41.200] Hydraulic control components.....	41.2
[41.206] Pump	41.3
[41.432] Autoguidance steering	41.4
[41.910] Auxiliary steering	41.5
Wheels	44
[44.520] Rear wheels.....	44.1
Tracks and track suspension	48
[48.100] Tracks	48.1
[48.130] Track frame and driving wheels	48.2
[48.134] Track tension units	48.3
[48.138] Track rollers	48.4
Cab climate control	50
[50.100] Heating.....	50.1
[50.200] Air conditioning	50.2
[50.300] Cab pressurizing system.....	50.3
Electrical systems	55
[55.000] Electrical system	55.1
[55.010] Fuel injection system.....	55.2
[55.012] Engine cooling system	55.3
[55.013] Engine oil system	55.4
[55.014] Engine intake and exhaust system.....	55.5
[55.015] Engine control system.....	55.6
[55.024] Transmission control system.....	55.7

[55.045] Front axle control system	55.8
[55.046] Rear axle control system.....	55.9
[55.050] Heating, Ventilation, and Air-Conditioning (HVAC) control system.....	55.10
[55.051] Cab Heating, Ventilation, and Air-Conditioning (HVAC) controls.....	55.11
[55.100] Harnesses and connectors.....	55.12
[55.130] Rear three-point hitch electronic control system	55.13
[55.201] Engine starting system	55.14
[55.301] Alternator.....	55.15
[55.302] Battery.....	55.16
[55.408] Warning indicators, alarms, and instruments	55.17
[55.512] Cab controls.....	55.18
[55.513] Cab transmission controls.....	55.19
[55.518] Wiper and washer system.....	55.20
[55.640] Electronic modules	55.21
[55.DTC] FAULT CODES.....	55.22
Platform, cab, bodywork, and decals	90
[90.100] Engine hood and panels	90.1
[90.102] Engine shields, hood latches, and trims	90.2
[90.124] Pneumatically-adjusted operator seat.....	90.3
[90.150] Cab.....	90.4
[90.151] Cab interior.....	90.5
[90.160] Cab interior trim and panels.....	90.6



INTRODUCTION

Foreword - Important notice regarding equipment servicing

All repair and maintenance work listed in this manual must be carried out only by qualified dealership personnel, strictly complying with the instructions given, and using, whenever possible, the special tools.

Anyone who performs repair and maintenance operations without complying with the procedures provided herein shall be responsible for any subsequent damages.

The manufacturer and all the organizations of its distribution chain, including - without limitation - national, regional, or local dealers, reject any responsibility for damages caused by parts and/or components not approved by the manufacturer, including those used for the servicing or repair of the product manufactured or marketed by the manufacturer. In any case, no warranty is given or attributed on the product manufactured or marketed by the manufacturer in case of damages caused by parts and/or components not approved by the manufacturer.

The information in this manual is up-to-date at the date of the publication. It is the policy of the manufacturer for continuous improvement. Some information could not be updated due to modifications of a technical or commercial type, or changes to the laws and regulations of different countries.

In case of questions, refer to your NEW HOLLAND Sales and Service Networks.

Safety rules

Personal safety





This is the safety alert symbol. It is used to alert you to potential personal injury hazards. Obey all safety messages that follow this symbol to avoid possible death or injury.

Throughout this manual you will find the signal words DANGER, WARNING, and CAUTION followed by special instructions. These precautions are intended for the personal safety of you and those working with you.

Read and understand all the safety messages in this manual before you operate or service the machine.

 DANGER indicates a hazardous situation that, if not avoided, will result in death or serious injury.

 WARNING indicates a hazardous situation that, if not avoided, could result in death or serious injury.

 CAUTION indicates a hazardous situation that, if not avoided, could result in minor or moderate injury.

FAILURE TO FOLLOW DANGER, WARNING, AND CAUTION MESSAGES COULD RESULT IN DEATH OR SERIOUS INJURY.

Machine safety

NOTICE: Notice indicates a situation that, if not avoided, could result in machine or property damage.

Throughout this manual you will find the signal word Notice followed by special instructions to prevent machine or property damage. The word Notice is used to address practices not related to personal safety.

Information

NOTE: Note indicates additional information that clarifies steps, procedures, or other information in this manual.

Throughout this manual you will find the word Note followed by additional information about a step, procedure, or other information in the manual. The word Note is not intended to address personal safety or property damage.

Safety rules - General maintenance safety

General maintenance safety

Keep the area used for servicing the machine clean and dry. Clean up spilled fluids.

Service the machine on a firm, level surface.

Install guards and shields after you service the machine.

Close all access doors and install all panels after servicing the machine.

Do not attempt to clean, lubricate, clear obstructions, or make adjustments to the machine while it is in motion or while the engine is running.

Always make sure that working area is clear of tools, parts, other persons and pets before you start operating the machine.

Unsupported hydraulic cylinders can lose pressure and drop the equipment, causing a crushing hazard. Do not leave equipment in a raised position while parked or during service, unless the equipment is securely supported.

Jack or lift the machine only at jack or lift points indicated in this manual.

Incorrect towing procedures can cause accidents. When you tow a disabled machine follow the procedure in this manual. Use only rigid tow bars.

Stop the engine, remove the key, and relieve pressure before you connect or disconnect fluid lines.

Stop the engine and remove the key before you connect or disconnect electrical connections.

Scalding can result from incorrect removal of coolant caps. Cooling systems operate under pressure. Hot coolant can spray out if you remove a cap while the system is hot. Allow the system to cool before you remove the cap. When you remove the cap, turn it slowly to allow pressure to escape before you completely remove the cap.

Replace damaged or worn tubes, hoses, electrical wiring, etc.

The engine, transmission, exhaust components, and hydraulic lines may become hot during operation. Take care when you service such components. Allow surfaces to cool before you handle or disconnect hot components. Wear protective equipment when appropriate.

When welding, follow the instructions in the manual. Always disconnect the battery before you weld on the machine. Always wash your hands after you handle battery components.



SERVICE MANUAL

Engine

T8.320 CVT TIER 2 [ZFRE05001 -], T8.350 CVT TIER 2 [ZFRE05001 -], T8.380 CVT TIER 2 [ZFRE05001 -], T8.380 SmartTrax™ CVT TIER 2 [ZFRE05001 -], T8.410 CVT TIER 2 [ZFRE05001 -], T8.410 SmartTrax™ CVT TIER 2 [ZFRE05001 -], T8.435 CVT TIER 2 [ZFRE05001 -], T8.435 SmartTrax™ CVT TIER 2 [ZFRE05001 -]

Visual external differences for T8. tractor engines

There are a few things that make the FPT **Cursor® 9** engine used in the T8. tractors visually and mechanically different from other **Cursor® 9** applications.

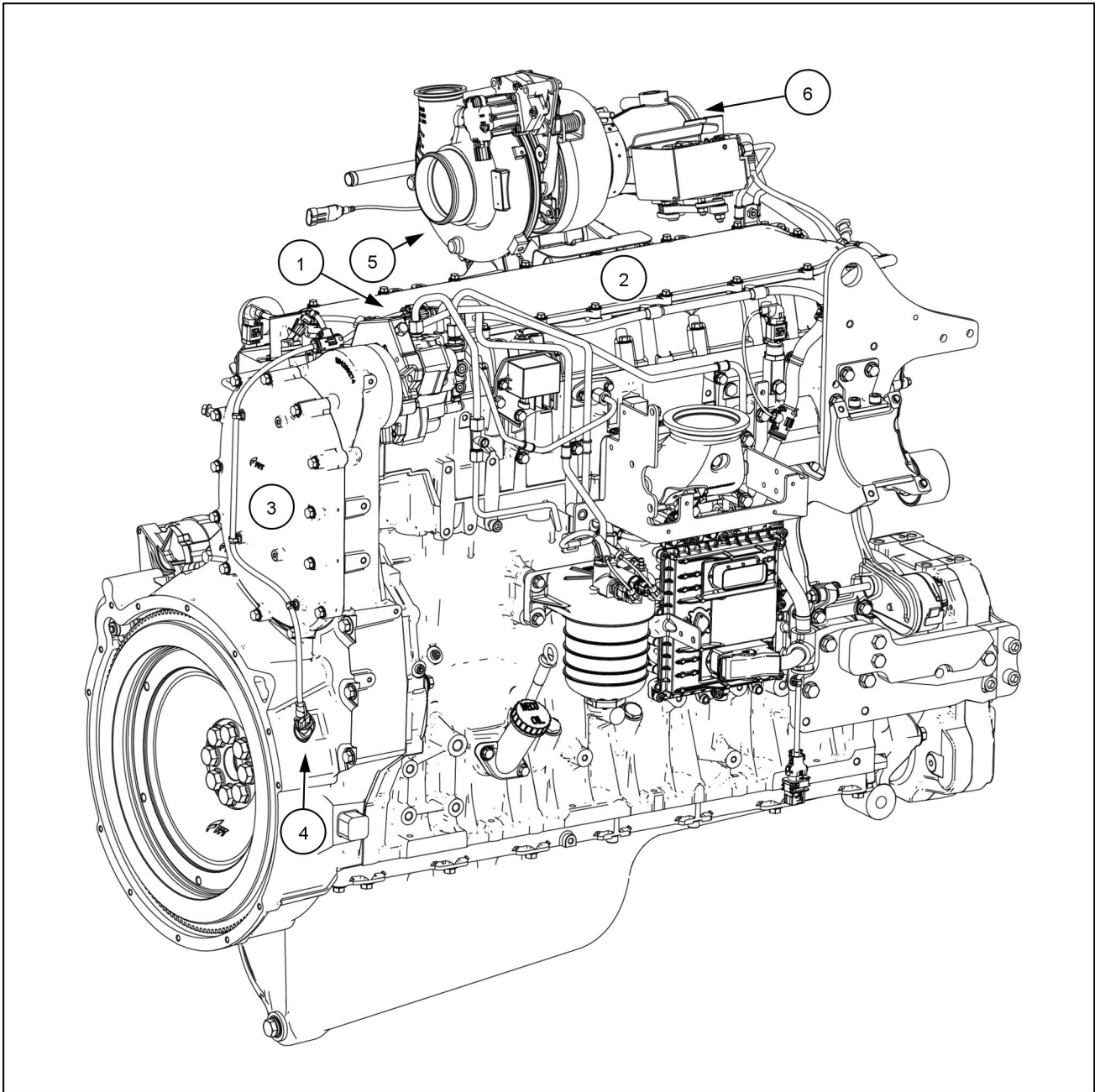

RAIL15TR00608GA 3

1. The fuel pump sits higher and closet to the center line of the engine.
2. A two piece valve cover assembly that allows for valve adjustment without removing the entire cover.
3. The rear cover is an oval shape where on other **Cursor® 9** engines it's round.
4. The flywheel speed sensor is located on the right side of the engine, others have on the left side of the engine.
5. The turbocharger is moved higher and toward the center line of the engine.
6. Exhaust flap for TIER 4B.

Exhaust brake

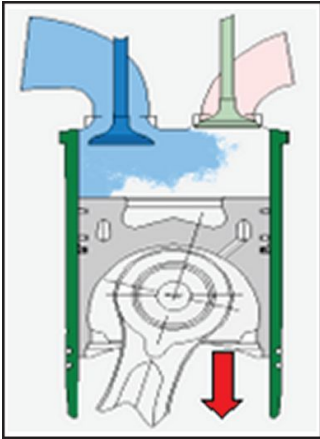

Admission phase:
Intake of fresh air.

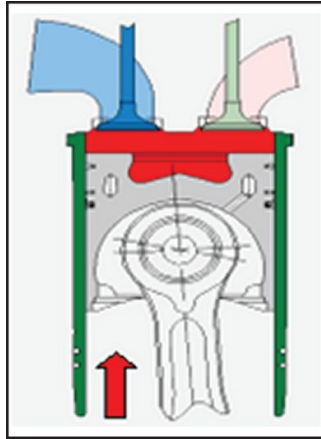

Compression phase:
Energy is stored in the compressed air, braking effect increases with compression

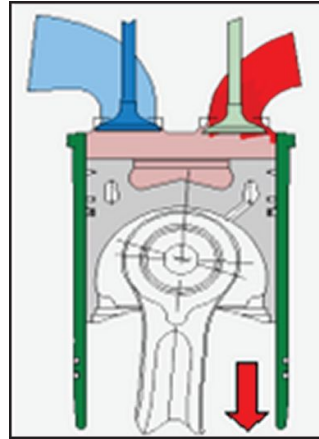

Top dead center:
Exhaust valves open, compressed air is released, energy is blown out.

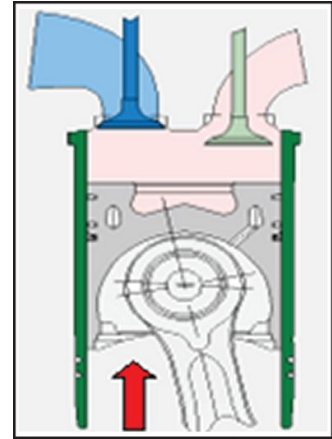

Exhaust phase:
Cylinder is empty, no energy exchange. Exhaust gases impact against the turbine, creating an additional braking effect.

All **Cursor®** engines are equipped with an advanced engine brake system: the Iveco Turbo Brake (IBT) system.

- Decompression engine brake
- Quick responding
- Integrated in the engine control
- Linked to cruise control
- Linked to EBS

Advantage

- Less brake pad wear
- Automatically engaged

Benefit

- Reduced operation cost
- Operator ease

The engine brake is controlled by the Tractor Control Unit (TCU). The Electronic Service Tool (EST) is used to configure the TCU as to whether or not the tractor has an engine brake.

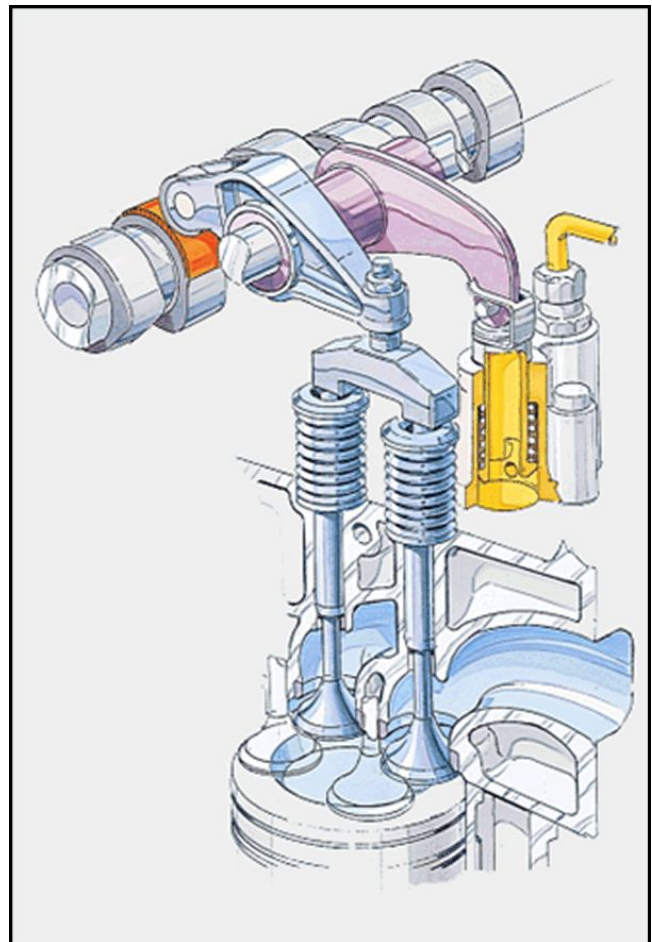

The engine brake is activated when the pedal left of the clutch is depressed.

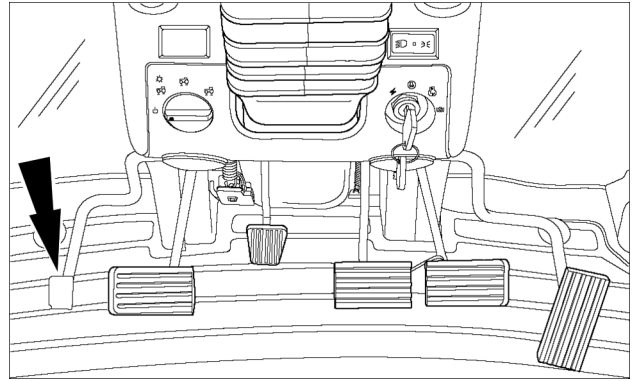

RCPH11CCH481AAA 4

Air Induction - cross flow cylinder head

The cylinder head is of the cross flow design, inlet on one side and exhaust on the other. This and four valves per cylinder give it excellent breathing ability and efficient temperature control. The air is supplied to the inlet by a wastegate turbocharger or a Variable Geometry Turbocharger (VGT).

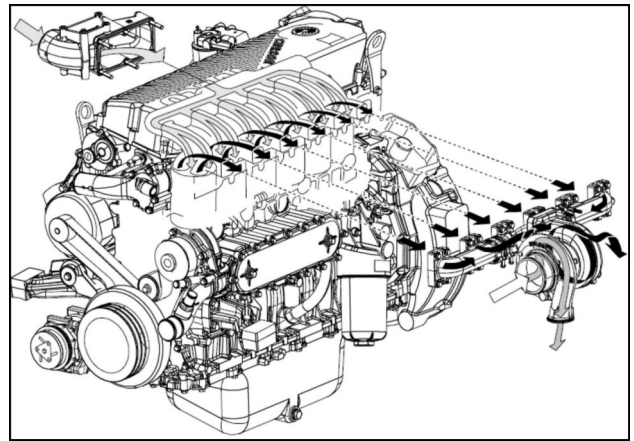

RAIL15TR00376BA 5

Wastegate turbocharger

The wastegate turbocharger allows for a larger turbocharger to be installed producing higher boost pressures in the low and midrange rpm while not over-boosting at high rpm.

Intake pressure builds against a diaphragm in the wastegate and opens a valve allowing exhaust to bypass the turbine therefore slowing the compressor and limiting the pressure in the intake manifold.

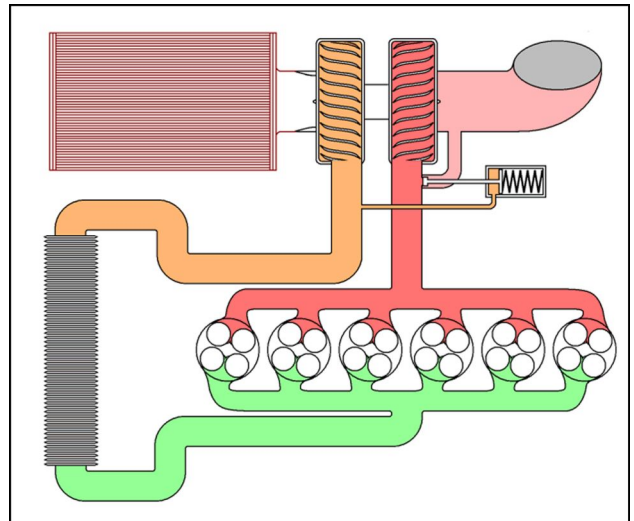

RAIL15TR00396BA 6



Suggest:

If the above button click is invalid.

Please download this document

first, and then click the above link

to download the complete manual.

Thank you so much for reading

Electronically Variable Geometry Turbocharger (eVGT)

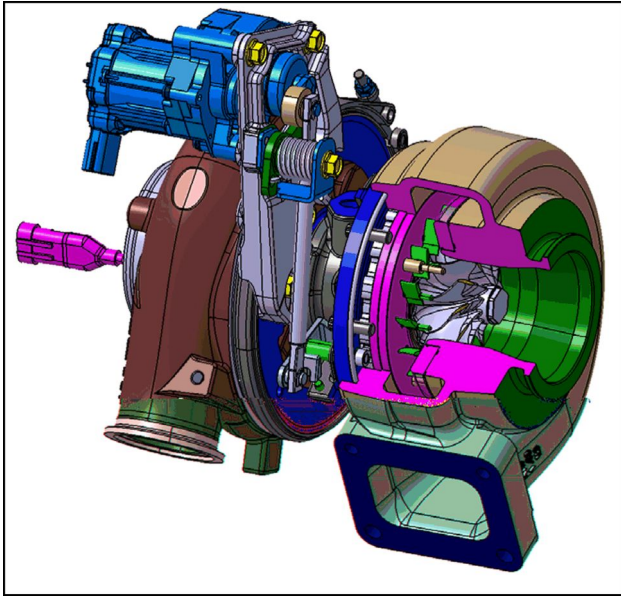

RAIL15TR00383BA 7

The electronically Variable Geometry Turbocharger (eVGT) is used on the TIER 4A T8.420 and TIER 4B T8.350, T8.380, T8.410 and T8.435. The eVGT is electronically controlled by the Engine Control Unit (ECU).

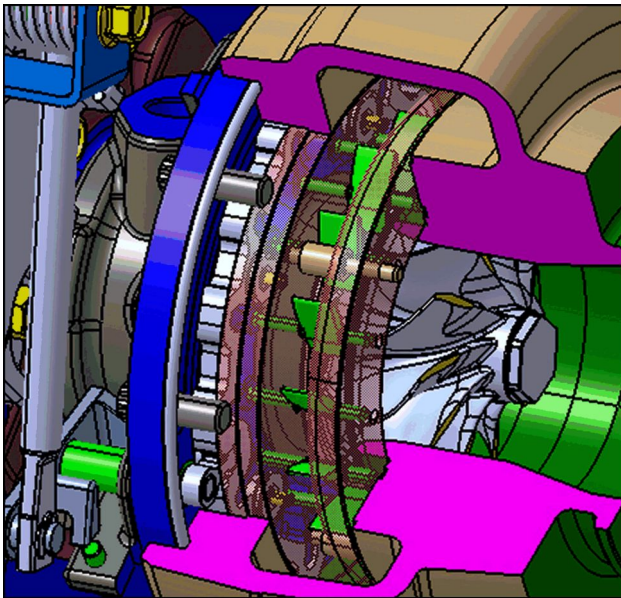

RAIL15TR00395BA 8

Vanes open (low boost)

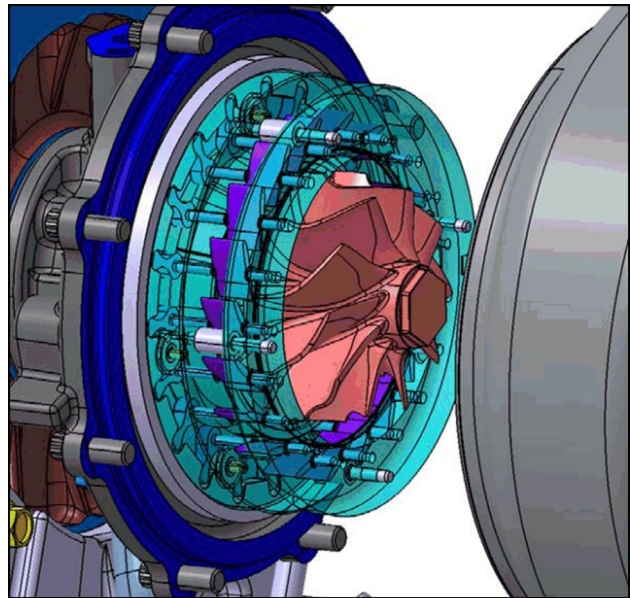

RAIL15TR00394BA 9

Vanes closed (high boost)

The eVGT uses a series of aerodynamic vanes to direct exhaust toward the turbine controlling both the velocity and angle the exhaust contacts the turbine. This gives the ECU the ability to dynamically “tune” the boost pressure at any given engine speed and load, Improving performance and fuel economy.

Fully open the velocity slows and the angle is decreased therefore the turbine and compressor turn slower producing less boost. When needed, the vanes close increasing the velocity and angle, therefore increasing turbine and compressor speed, producing higher boost anytime it is needed across the entire operating range of the engine.

<https://www.ebooklibonline.com>

Hello dear friend!

Thank you very much for reading.

Enter the link into your browser.

The full manual is available for immediate download.

<https://www.ebooklibonline.com>