

SERVICE MANUAL

E37C

Mini Excavator

Part number 48127448

English
May 2017





SERVICE MANUAL

E37C Cab - Tier IV final engine
E37C Canopy - Tier IV final engine

Contents

INTRODUCTION

Engine.....	10
[10.001] Engine and crankcase	10.1
[10.106] Valve drive and gears	10.2
[10.101] Cylinder heads	10.3
[10.105] Connecting rods and pistons.....	10.4
[10.103] Crankshaft and flywheel.....	10.5
[10.216] Fuel tanks	10.6
[10.206] Fuel filters	10.7
[10.218] Fuel injection system.....	10.8
[10.202] Air cleaners and lines	10.9
[10.501] Exhaust Gas Recirculation (EGR) exhaust treatment.....	10.10
[10.400] Engine cooling system	10.11
[10.414] Fan and drive	10.12
[10.304] Engine lubrication system.....	10.13
Hydraulic systems.....	35
[35.000] Hydraulic systems.....	35.1
[35.106] Variable displacement pump	35.2
[35.359] Main control valve.....	35.3
[35.357] Pilot system	35.4
[35.355] Hydraulic hand control	35.5
[35.356] Hydraulic foot control.....	35.6
[35.352] Hydraulic swing system	35.7
[35.353] Hydraulic travel system	35.8
[35.354] Hydraulic central joint	35.9
[35.736] Boom hydraulic system	35.10
[35.737] Dipper hydraulic system.....	35.11

<https://www.ebooklibonline.com>

Hello dear friend!

Thank you very much for reading.

Enter the link into your browser.

The full manual is available for immediate download.

<https://www.ebooklibonline.com>

[35.738] Excavator and backhoe bucket hydraulic system	35.12
[35.739] Swing arm hydraulic system	35.13
[35.741] Dozer blade cylinders	35.14
Frames and ballasting	39
[39.140] Ballasts and supports	39.1
Tracks and track suspension	48
[48.130] Track frame and driving wheels	48.1
[48.100] Tracks	48.2
[48.134] Track tension units	48.3
[48.138] Track rollers	48.4
Electrical systems	55
[55.000] Electrical system	55.1
[55.100] Harnesses and connectors	55.2
[55.525] Cab engine controls	55.3
[55.015] Engine control system	55.4
[55.201] Engine starting system	55.5
[55.301] Alternator	55.6
[55.302] Battery	55.7
[55.011] Fuel tank system	55.8
[55.014] Engine intake and exhaust system	55.9
[55.012] Engine cooling system	55.10
[55.013] Engine oil system	55.11
[55.512] Cab controls	55.12
[55.524] Cab controls (Lift arm, Boom, Dipper, Bucket)	55.13
[55.518] Wiper and washer system	55.14
[55.404] External lighting	55.15
[55.405] External lighting switches and relays	55.16
[55.514] Cab lighting	55.17

[55.408] Warning indicators, alarms, and instruments	55.18
Booms, dippers, and buckets	84
[84.114] Boom pivoting support	84.1
[84.910] Boom	84.2
[84.912] Dipper arm	84.3
[84.100] Bucket.....	84.4
Platform, cab, bodywork, and decals	90
[90.100] Engine hood and panels	90.1
[90.105] Machine shields and guards	90.2



INTRODUCTION

Foreword - Important notice regarding equipment servicing

All repair and maintenance work listed in this manual must be carried out only by qualified dealership personnel, strictly complying with the instructions given, and using, whenever possible, the special tools.

Anyone who performs repair and maintenance operations without complying with the procedures provided herein shall be responsible for any subsequent damages.

The manufacturer and all the organizations of its distribution chain, including - without limitation - national, regional, or local dealers, reject any responsibility for damages caused by parts and/or components not approved by the manufacturer, including those used for the servicing or repair of the product manufactured or marketed by the manufacturer. In any case, no warranty is given or attributed on the product manufactured or marketed by the manufacturer in case of damages caused by parts and/or components not approved by the manufacturer.

The manufacturer reserves the right to make improvements in design and changes in specifications at any time without notice and without incurring any obligation to install them on units previously sold. Specifications, descriptions, and illustrative material herein are as accurate as known at time of publication but are subject to change without notice.

In case of questions, refer to your NEW HOLLAND CONSTRUCTION Sales and Service Networks.

Safety rules

Personal safety



This is the safety alert symbol. It is used to alert you to potential personal injury hazards. Obey all safety messages that follow this symbol to avoid possible death or injury.

Throughout this manual you will find the signal words DANGER, WARNING, and CAUTION followed by special instructions. These precautions are intended for the personal safety of you and those working with you.

Read and understand all the safety messages in this manual before you operate or service the machine.

 DANGER indicates a hazardous situation that, if not avoided, will result in death or serious injury.

 WARNING indicates a hazardous situation that, if not avoided, could result in death or serious injury.

 CAUTION indicates a hazardous situation that, if not avoided, could result in minor or moderate injury.

FAILURE TO FOLLOW DANGER, WARNING, AND CAUTION MESSAGES COULD RESULT IN DEATH OR SERIOUS INJURY.

Machine safety

NOTICE: Notice indicates a situation that, if not avoided, could result in machine or property damage.

Throughout this manual you will find the signal word Notice followed by special instructions to prevent machine or property damage. The word Notice is used to address practices not related to personal safety.

Information

NOTE: Note indicates additional information that clarifies steps, procedures, or other information in this manual.

Throughout this manual you will find the word Note followed by additional information about a step, procedure, or other information in the manual. The word Note is not intended to address personal safety or property damage.

Safety rules - General information

Cleaning

Clean the metal parts with cleaning solution that meets the standard and steam cleaning. (except for bearings)

After cleaning, dry well, and inject oil in all parts.

Also inject oil into the bearings after drying.

Inspection

When disassembling parts, check all the parts.

If there are any worn or damaged parts, replace them.

Inspect carefully to prevent initial breakdowns.

Bearing

Replace any loose bearings.

Air dry bearings before installing them.

Needle bearing

When inserting needle bearings, be very careful not to damage them.

Apply grease to the section where the needle bearing will be inserted.

Gear

Check that there is no wear and no damage.

Oil seal, O-ring, gasket

Always install new oil seals, O-rings, and gaskets.

Apply grease to sections where oil seals and O-rings will be inserted.

Shaft

Check that there is no wear and no damage.

Check the bearings and check for damaged oil seals on the shaft.

Service parts

Install NEW HOLLAND CONSTRUCTION genuine service parts.

When placing an order, check the parts catalog. It contains the NEW HOLLAND CONSTRUCTION genuine part numbers.

Any breakdowns arising from the installation of non-genuine parts are not covered by the warranty.

Lubricants (fuel, hydraulic oil)

Use the oil from the specified company or specified in the operator's manual or service Manual.

Any breakdowns arising from any fuel or hydraulic oil other than those specified are not covered by the warranty.

Product identification

Your machine is a hydraulic excavator. It consists of an undercarriage fitted with tracks and a swing bearing which supports the upper-structure frame. The upper-structure frame supports the attachment at the front end of the machine, plus the engine, hydraulics and the cab/canopy. When the operator works the controls, the engine-driven pump delivers hydraulic fluid to the control valves. The control valves distribute the hydraulic fluid to the various cylinders and hydraulic motors employed. A cooling system maintains the hydraulic fluid at normal operating temperature.

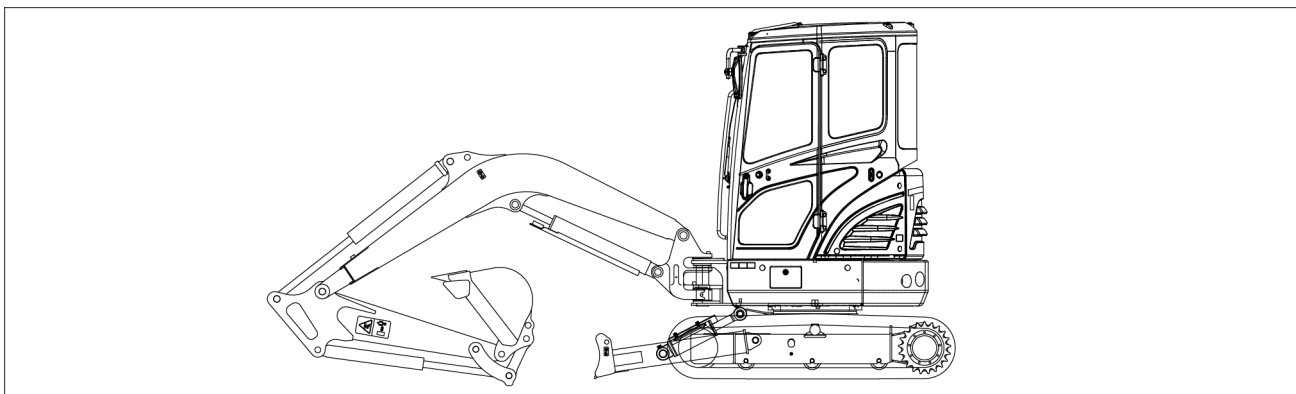

SMIL16MEX0363EA 1

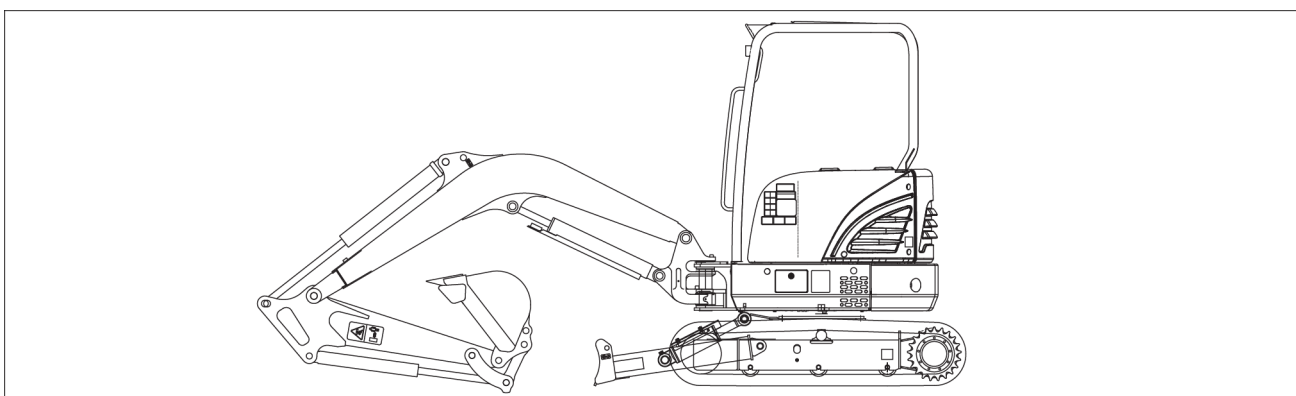
Cab version

SMIL16MEX0629EA 2

Canopy version

When ordering parts, obtaining information, or seeking assistance, always supply your NEW HOLLAND CONSTRUCTION Dealer with the type and Product Identification Number (PIN) of your machine or accessories.

Write the following in the spaces below:

- Machine Type
- Machine PIN
- Machine year of manufacture
- Serial numbers of hydraulic and mechanical components



SERVICE MANUAL

Engine

E37C Cab - Tier IV final engine
E37C Canopy - Tier IV final engine

Engine - Component identification

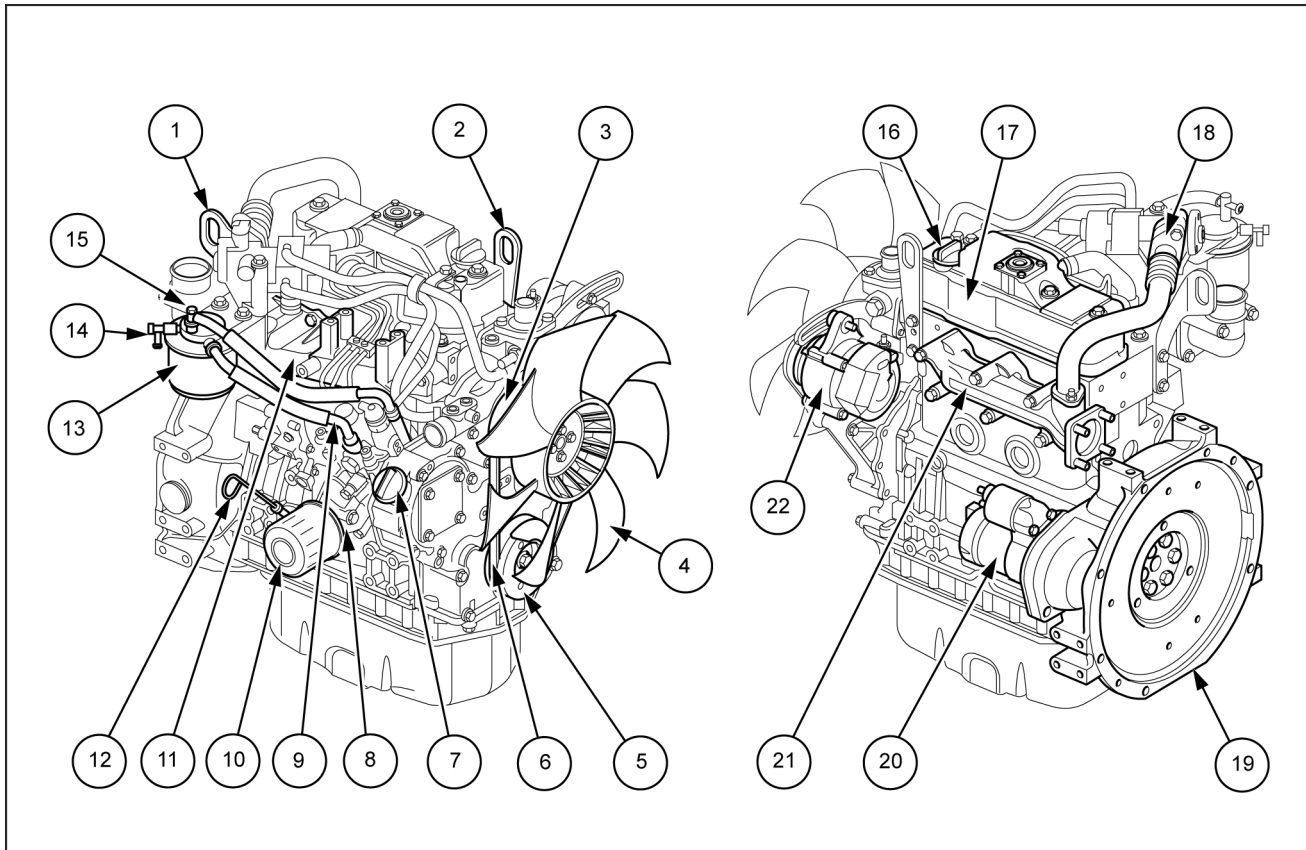

SMIL17MEX0127FB 1

- | | |
|---|----------------------------------|
| 1. Lifting eye (flywheel end) | 12. Dipstick (engine oil) |
| 2. Lifting eye (engine cooling fan end) | 13. Fuel filter |
| 3. Engine coolant pump | 14. Fuel return to fuel tank |
| 4. Engine cooling fan | 15. Fuel inlet |
| 5. Crankshaft V-pulley | 16. Top filler port (engine oil) |
| 6. V-belt | 17. Rocker arm cover |
| 7. Side filler port (engine oil) | 18. EGR valve |
| 8. Engine oil cooler | 19. Flywheel |
| 9. Fuel injection pump | 20. Starter motor |
| 10. Engine oil filter | 21. Exhaust manifold |
| 11. Intake manifold | 22. Alternator |

NOTE: engine oil drain plug location may vary depending on oil pan options.

Engine - Exploded view

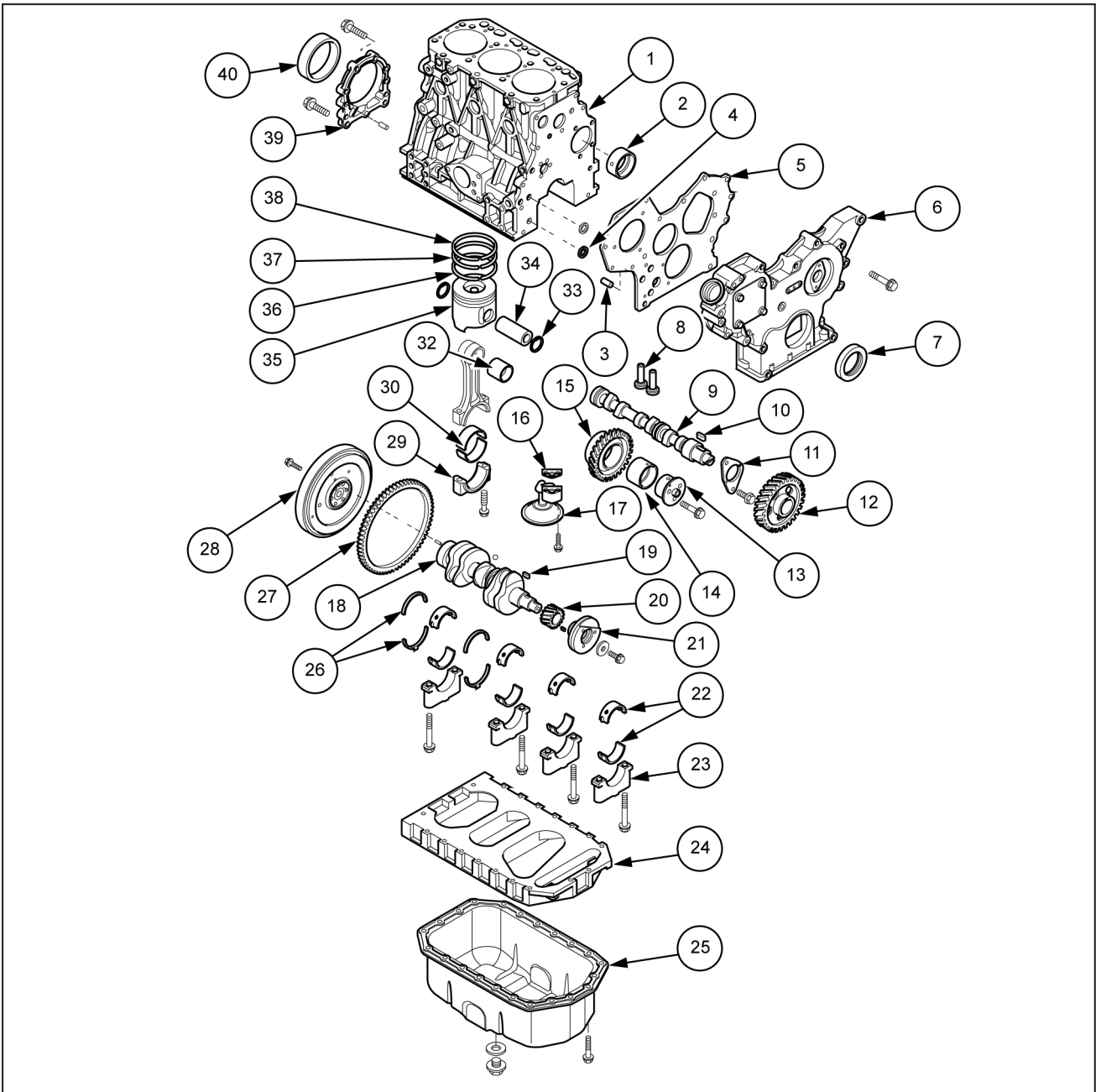

SMIL17MEX0144GB 1

- | | |
|--------------------------|------------------------------------|
| 1. Cylinder block | 21. Crankshaft pulley |
| 2. Camshaft bushing | 22. Main bearing inserts |
| 3. Dowel (2 used) | 23. Main bearing cap |
| 4. O-ring | 24. Oil pan spacer |
| 5. Front plate | 25. Oil pan |
| 6. Gear case cover | 26. Thrust bearings |
| 7. Front crankshaft seal | 27. Ring gear |
| 8. Tappets | 28. Flywheel |
| 9. Camshaft | 29. Connecting rod cap |
| 10. Camshaft gear key | 30. Connecting rod bearing inserts |
| 11. Camshaft end plate | 31. Connecting rod |
| 12. Camshaft gear | 32. Wrist pin bushing |
| 13. Idler gear shaft | 33. Circlip |
| 14. Idler gear bushing | 34. Wrist pin |

- | | |
|-------------------------|----------------------------------|
| 15. Idler gear | 35. Piston |
| 16. Oil pickup gasket | 36. Oil ring |
| 17. Oil pickup | 37. Second compression ring |
| 18. Crankshaft | 38. Top compression ring |
| 19. Crankshaft gear key | 39. Crankshaft rear seal housing |
| 20. Crankshaft gear | 40. Crankshaft rear seal |

Engine - Dynamic description

Function of major engine components

Components	Functions
Air cleaner	The air cleaner prevents airborne contaminants from entering the engine. Since the air cleaner is application specific, it must be carefully selected by an application engineer.
Alternator	The alternator is driven by a V-belt which is powered by the crankshaft Vpulley. The alternator supplies electricity to the engine systems and charges the battery while the engine is running.
Dipstick (engine oil)	The engine oil dipstick is used to determine the amount of engine oil in the crankcase.
Electric fuel pump	The electric fuel pump makes sure there is a constant supply of diesel fuel to the fuel injection pump. The electric fuel pump is electro-magnetic and runs on 12 V DC. It must be installed on every application. This is standard equipment with every engine.
Engine oil filter	The engine oil filter removes contaminants and sediments from the engine oil.
Engine oil cooler	The engine oil cooler helps to keep the engine oil cool. Engine coolant from the cooling system is circulated through an adapter at the base of the engine oil filter assembly and then returned to the coolant pump inlet.
Fuel filter	The fuel filter removes contaminants and sediments from the diesel fuel.
Water separator	The water separator removes contaminants, sediment and water from diesel fuel going to the fuel filter. This is a required component of the fuel system and is standard equipment with every engine. The water separator is installed between the fuel tank and the fuel feed pump. Periodically drain the water from the water separator.
Fuel tank	The fuel tank is a reservoir that holds diesel fuel. When the fuel leaves the fuel tank it goes to the fuel filter/water separator. Next the fuel is pumped to the fuel filter by the electric fuel pump. Then the fuel goes to the fuel injection pump. Since the fuel is used to keep the fuel injection pump cool and lubricated, more fuel than necessary enters the injection pump. When the injection pump pressure reaches a preset value, a relief valve allows the excess fuel to be returned back to the fuel tank. The fuel tank is a required engine component.
Side and top filler port (engine oil)	You can fill the crankcase with engine oil from either the side or the top filler port depending upon which one is most convenient.
Starter motor	The starter motor is powered by the battery. When you turn the key switch in the operator's console to the START position, the starter motor engages with the ring gear installed on the flywheel and starts the flywheel in motion.

Main electronic control components and features

Components / feature		Description
Engine Control Unit (ECU)		The ECU adjusts the rack position of the fuel injection pump depending on the speed command signal from the accelerator sensor, thus regulating the engine speed and power. The ECU also regulates the opening of the EGR valve depending on the engine speed and power. It serves as the master station for the following components/features.
Electronic governor (eco-governor)		The electronic governor consists of the engine speed sensor, the rack actuator, etc., and is directly connected to the fuel injection pump in order to regulate the rack position of the fuel injection pump depending on the signals communicated with the ECU.
Fuel injection pump (for eco-governor)		The fuel injection pump is of single plunger type and it is equipped with a Cold System Device (CSD) solenoid valve that allows the fuel injection timing to advance and the injection quantity to increase, thereby improving the cold start performance of the engine.
EGR valve		Controls the exhaust gas recirculation flow rate depending on the engine speed/load signals from the ECU. It is installed on the top of the exhaust manifold.
Accelerator sensor		Unlike mechanical governors, the Eco-governor has no governor lever. The accelerator sensor serves as the governor lever to provide the speed command signal (voltage signal) to the ECU for engine speed control. It is installed in the operator cabin of the driven machine. Constant speed engines for e.g. generator use do not require accelerator sensors because the engine speed can be shifted via a switch on the operator's console.
	Optional	CAN communication capability is available as an option.
Fault indicator		Is installed on the operator's console. If a fault occurs in the ECU or Eco-governor, the fault indicator flashes alerting the operator to a fault. The number of flashes and/or the flashing pattern vary depending on the type or source of the fault, Optional enabling quick-fix.
	Optional	
Engine diagnosis tool		Allows the operator to troubleshoot the cause of a problem based on detailed information regarding the problem occurring in the ECU or eco-governor. This tool can also be used for data maintenance tasks including programming and mapping.
	Option for service	
Engine coolant temperature sensor		Allows the CSD to be controlled in engine cold start conditions.
Glow plugs	Optional	When the key switch is turned to the ON position, the glow plugs/air heater are/is energized for up to 15 seconds (glow plugs). The duration of energization depends on the engine coolant temperature. The HEAT indicator is on during energization. When the indicator goes out, turn the key switch to the START position to start the engine.
Droop control	Standard with VM series	Reduces the engine speed by a certain percentage from no load to full (rated) load in steady state operation. The same percentage droop is maintained even when the load increases at any no-load speed.
Isochronous control	Standard with CL series Optional with VM series	Offers a constant engine speed from no load to full load. The engine speed does not decrease even when the load increases at any no-load speed.
Low-idling speed up		When the engine is cold, increases the low-idling speed to up to 1000 RPM depending on the engine coolant temperature. When the coolant temperature reaches a predetermined value, this feature returns the engine speed to the normal low idle setting, thus reducing the warm-up time.



Suggest:

If the above button click is invalid.

Please download this document

first, and then click the above link

to download the complete manual.

Thank you so much for reading

Engine - Engine and crankcase

Components / feature		Description
High-idling speed down	Optional	Decreases the high-idling speed depending on the engine coolant temperature. When the coolant temperature falls to a predetermined value, this feature returns the engine speed to the normal high idle setting, thus minimizing the emission of white smoke at low temperatures.
Auto deceleration	Optional	Brings the running engine in low idle mode automatically when the accelerator pedal is not operated for a predetermined period of time. When the pedal is operated, for example, the accelerator sensor is activated, the low idle mode is cancelled.

<https://www.ebooklibonline.com>

Hello dear friend!

Thank you very much for reading.

Enter the link into your browser.

The full manual is available for immediate download.

<https://www.ebooklibonline.com>