

SERVICE MANUAL

CX5080 Elevation / CX5090 Elevation
CX5090 Laterale / CX5090 Hillside
CX6080 Elevation / CX6090 Elevation
CX6090 Laterale
Combine

Part number 47824864

English

February 2015





SERVICE MANUAL

CX5000 Elevation series Tier IV
CX6000 Elevation series Tier IV

Link Product / Engine

Product	Market Product	Engine
CX5090 Laterale	Asia Pacific	F4HFE613T*A005
CX5080 Elevation	Europe	F4HFE613U*A005
CX5090 Elevation	Europe	F4HFE613T*A005
CX5090 Laterale	Middle East Africa	F4HFE613T*A005
CX5090 Hillside	Europe	F4HFE613T*A005
CX5090 Laterale	Europe	F4HFE613T*A005
CX6090 Laterale	Asia Pacific	F2CFE613L*A
CX6090 Elevation	Europe	F2CFE613L*A
CX6090 Laterale	Middle East Africa	F2CFE613L*A
CX6080 Elevation	Europe	F4HFE613T*A005
CX6090 Laterale	Europe	F2CFE613L*A

<https://www.ebooklibonline.com>

Hello dear friend!

Thank you very much for reading.

Enter the link into your browser.

The full manual is available for immediate download.

<https://www.ebooklibonline.com>

Contents

INTRODUCTION

Engine	10
[10.500] Selective Catalytic Reduction (SCR) exhaust treatment.....	10.1
[10.001] Engine and crankcase	10.2
[10.450] Engine air compressor	10.3
Main gearbox and drive	14
[14.100] Main gearbox and drive	14.1
Transmission	21
[21.114] Mechanical transmission	21.1
[21.130] Mechanical transmission external controls.....	21.2
[21.145] Gearbox internal components.....	21.3
[21.182] Differential.....	21.4
Front axle system	25
[25.310] Final drives	25.1
Rear axle system	27
[27.120] Planetary and final drives	27.1
[27.100] Powered rear axle.....	27.2
Hydrostatic drive	29
[29.100] Transmission and steering hydrostatic control	29.1
[29.204] Reservoir, cooler, and lines	29.2
[29.218] Pump and motor components.....	29.3
[29.202] Hydrostatic transmission	29.4
[29.300] Rear hydrostatic transmission.....	29.5
Brakes and controls	33
[33.202] Hydraulic service brakes	33.1
[33.110] Parking brake or parking lock	33.2

Hydraulic systems	35
[35.000] Hydraulic systems.....	35.1
[35.300] Reservoir, cooler, and filters.....	35.2
[35.106] Variable displacement pump	35.3
[35.359] Main control valve.....	35.4
[35.610] Machine leveling control system	35.5
[35.630] Machine lateral leveling system.....	35.6
[35.640] Machine longitudinal leveling system	35.7
[35.410] Header or attachment height system	35.8
[35.602] Header or attachment leveling system	35.9
[35.518] Reel control system	35.10
[35.760] Header reverser drive	35.11
Steering	41
[41.101] Steering control	41.1
[41.200] Hydraulic control components.....	41.2
[41.206] Pump.....	41.3
[41.216] Cylinders	41.4
[41.432] Autoguidance steering	41.5
Cab climate control	50
[50.100] Heating.....	50.1
[50.200] Air conditioning	50.2
Electrical systems	55
[55.000] Electrical system	55.1
[55.100] Harnesses and connectors.....	55.2
[55.988] Selective Catalytic Reduction (SCR) electrical system	55.3
[55.640] Electronic modules.....	55.4
[55.019] Hydrostatic drive control system	55.5
[55.051] Cab Heating, Ventilation, and Air-Conditioning (HVAC) controls.....	55.6

[55.050] Heating, Ventilation, and Air-Conditioning (HVAC) control system.....	55.7
[55.404] External lighting	55.8
[55.405] External lighting switches and relays	55.9
[55.834] Sieve electric control	55.10
[55.408] Warning indicators, alarms, and instruments	55.11
[55.785] Precision farming system	55.12
[55.426] Harvest material flow control system.....	55.13
Attachments/Headers.....	58
[58.105] Attachment/Header reel control system.....	58.1
[58.900] Belt feeding	58.2
Product feeding	60
[60.101] Feed roll.....	60.1
[60.105] Floating roll, feed chain, and drive	60.2
[60.110] Feeder housing.....	60.3
[60.150] Feeder drive system	60.4
[60.122] Length-of-cut gearbox.....	60.5
Threshing	66
[66.000] Threshing	66.1
[66.330] Drum	66.2
[66.321] Drum/Rotor variator with electrical control	66.3
[66.105] Concave.....	66.4
[66.110] Concave control system.....	66.5
Separation	72
[72.350] Beater	72.1
[72.420] Rotary separator	72.2
[72.410] Rotary separator drive system	72.3
[72.440] Straw-flow beater	72.4
[72.101] Straw walkers and shafts	72.5

Cleaning	74
[74.000] Cleaning.....	74.1
[74.101] Cleaning drive systems	74.2
[74.110] Grain pan.....	74.3
[74.114] Upper shaker shoe	74.4
[74.118] Lower shaker shoe	74.5
[74.130] Fan housing.....	74.6
[74.136] Fan drive system.....	74.7
[74.140] Tailings return system	74.8
Crop storage / Unloading	80
[80.101] Clean grain elevator.....	80.1
[80.150] Grain tank	80.2
[80.175] Grain tank unload drive system	80.3
[80.180] Grain tank unload	80.4
Platform, cab, bodywork, and decals	90
[90.154] Cab doors and hatches	90.1
[90.105] Machine shields and guards	90.2



INTRODUCTION

Foreword

IMPORTANT INFORMATION

All repair and maintenance works listed in this manual must be carried out only by staff belonging to the NEW HOLLAND Service network, strictly complying with the instructions given and using, whenever required, the special tools.

Anyone who carries out the above operations without complying with the prescriptions shall be responsible for the subsequent damages.

The manufacturer and all the organizations of its distribution chain, including - without limitation - national, regional or local dealers, reject any responsibility for damages due to the anomalous behavior of parts and/or components not approved by the manufacturer himself, including those used for the servicing or repair of the product manufactured or marketed by the Manufacturer. In any case, no warranty is given or attributed on the product manufactured or marketed by the Manufacturer in case of damages due to an anomalous behavior of parts and/or components not approved by the Manufacturer.

No reproduction, though partial of text and illustrations allowed

Foreword

Technical Information

This manual has been produced by a new technical information system. This new system is designed to deliver technical information electronically through CD-ROM and in paper manuals. A coding system called ICE has been developed to link the technical information to other Product Support functions, e.g. Warranty.

Technical information is written to support the maintenance and servicing of the functions or systems of the customer's machine. When a customer has a concern about a machine, it is usually because a function or system in the machine is not working at all, not working efficiently, or not responding correctly to commands. When you refer to the technical information in this manual to resolve the customer's concern, you will find all the information classified using the new ICE coding, based on that machine's functions or systems. Once you have located the technical information for that function or system, you will find all the mechanical, electrical or hydraulic devices, components, assemblies and sub-assemblies for that function or system. You will also find all the types of information that have been written for that function or system, the technical data (specifications), the functional data (how it works), the diagnostic data (fault codes and troubleshooting) and the service data (remove, install adjust, etc.).

By integrating this new ICE coding into the technical information, you will be able to search for and retrieve the right piece of technical information needed to resolve the customer's concern about the machine. This is made possible by attaching 3 categories to each piece of technical information during the authoring process.

The first category is the Location, the second category is the Information Type and the third category is the Product:

- LOCATION - is the component or function on the machine that the technical information is going to describe, e.g. Fuel tank.
- INFORMATION TYPE - is the technical information that has been written for a particular component or function on the machine, e.g. Capacity would be a type of Technical Data describing the amount of fuel held by the fuel tank.
- PRODUCT - is the model for which the technical information is written.

Every piece of technical information will have those 3 categories attached to it. You will be able to use any combination of those categories to find the right piece of technical information you need to resolve the customer's concern about the machine.

This information could be:

- the description of how to remove the cylinder head
- a table of specifications for a hydraulic pump
- a fault code
- a troubleshooting table
- a special tool

How to Use this Manual

This manual is divided into Sections. Each Section is then divided into Chapters. Contents pages are included at the beginning of the manual, then inside every Section and inside every Chapter. There is an alphabetic index at the end of every Chapter. Page number references are included for every piece of technical information listed in the Chapter Contents or Chapter Index.

Each Chapter is divided into four Information types:

- Technical Data (specifications) for all the mechanical, electrical or hydraulic devices, components and assemblies.
- Functional Data (how it works) for all the mechanical, electrical or hydraulic devices, components and assemblies.
- Diagnostic Data (fault codes, electrical and hydraulic troubleshooting) for all the mechanical, electrical or hydraulic devices, components and assemblies.
- Service data (remove disassembly, assemble, install) for all the mechanical, electrical or hydraulic devices, components and assemblies.

Sections

Sections are grouped according to the machine's main functions or systems. Each Section is identified by a letter A, B, C etc. The number of Sections in the manual will depend on the type and function of the machine for which it is written. Each Section has a Contents page listed in alphabetic/numeric order. This table illustrates which Sections could be included in a manual for a particular product.

PRODUCT	SECTION												
	A - Distribution Systems												
	B - Power Production												
	C - Power Train												
	D - Travelling												
	E - Body and Structure												
	F - Frame Positioning												
	G - Tool Positioning												
	H - Working Arm												
	J - Tools and Couplers												
	K - Crop Processing												
	L - Field Processing												
Tractors	X	X	X	X	X	X		X	X				
Vehicles with working arms: backhoes, excavator, front end loaders with shoes.....	X	X	X	X	X	X	X	X	X				
Harvesters, forage harvesters, balers....	X	X	X	X	X	X	X	X	X	X			
Seeder, planter, floater, pulverising equipment....	X	X	X	X	X	X		X			X		
Mounted equipment and tools.....					X	X	X		X				

Safety rules

LEGAL OBLIGATIONS

This machine may be equipped with special guarding or other devices in compliance with local legislation. Some of these require active use by the operator. Therefore, check local legislations on the usage of this machine.

ACCIDENT PREVENTION

Most accidents or injuries that occur in workshops are the result of non compliance to simple and fundamental safety principles. For this reason, **IN MOST CASES THESE ACCIDENTS CAN BE AVOIDED** by applying the fundamental safety principles, acting with the necessary caution and care.

Accidents may occur with all types of machine, regardless of how well the machine in question was designed and built.

⚠ CAUTION

Unexpected machine movement!

- 1. Disengage all drives.**
- 2. Engage parking brake.**
- 3. Lower all attachments to the ground, or raise and engage all safety locks.**
- 4. Shut off engine.**
- 5. Remove key from key switch.**
- 6. Switch off battery key, if installed.**
- 7. Wait for all machine movement to stop.**

Failure to comply could result in minor or moderate injury.

C0038A

SAFETY REQUIREMENTS FOR FLUID POWER SYSTEMS AND COMPONENTS - HYDRAULICS (EUROPEAN STANDARD EN982)

- Flexible hose assemblies must not be constructed from hoses which have been previously used as part of a hose assembly.
- Do not weld hydraulic pipes: when flexible hoses or piping are damaged, replace them immediately.
- It is forbidden to modify a hydraulic accumulator by machining, welding or any other way.
- Before removing hydraulic accumulators for servicing, the liquid pressure in the accumulators must be reduced to zero.
- Pressure check on hydraulic accumulators must be carried out by a method recommended by the accumulator manufacturer.
- Take care not to exceed the maximum allowed pressure of the accumulator. After any check or adjustment, check for leakages or gas in the hoses or tubes.

SAFETY RULES

General guidelines

- Carefully follow specified repair and maintenance procedures.
- When appropriate, use P.P.E (Personal Protective Equipment)
- Do not wear rings, wristwatches, jewellery, unbuttoned or loose articles of clothing such as: ties, torn clothing, scarves, open jackets or shirts with open zips that may remain entangled in moving parts. It is advised to wear approved safety clothing, e.g.: non-slip footwear, gloves, safety goggles, helmets, etc.
- Do not carry out repair operations with someone sitting in the driver's seat, unless the person is a trained technician who is assisting with the operation in question.
- Do not operate the machine or use any of the implements from different positions, other than the driver's seat.
- Do not carry out operations on the machine with the engine running, unless specifically indicated.

INTRODUCTION

- Bring all hydraulic cylinders to the home positions (down, retracted, etc.) before engine shut down.
- Stop the engine and check that the hydraulic circuits are pressure-free before removing caps, covers, valves, etc.
- All repair and maintenance operations must be carried out using extreme care and attention.
- Service steps and platforms used in the workshop or elsewhere should be built according to the applicable standards and legislation.
- Disconnect the Power Take-Off (PTO) and label the controls to indicate that the machine is being serviced.
- Brakes are inoperative when manually released for repair or maintenance purposes. Use blocks or similar devices to secure the machine in these conditions.
- Only use specified towing points for towing the machine. Connect parts carefully. Make sure that all pins and/or locks are secured in position before applying traction. Never remain near the towing bars, cables or chains that are operating under load.
- When loading or unloading the machine from the trailer (or other means of transport), select a flat area capable of sustaining the trailer or truck wheels. Firmly secure the machine to the truck or trailer and lock the wheels in the position used by the carrier.
- Electric heaters, battery-chargers and similar equipment must only be powered by auxiliary power supplies with efficient ground insulation to avoid electrical shock hazards.
- Always use suitable hoisting or lifting devices when raising or moving heavy parts.
- Keep bystanders away.
- Never use gasoline, diesel oil or other inflammable liquids as cleaning agents. Use non-inflammable, non toxic commercially available solvents.
- Wear safety goggles with side guards when cleaning parts with compressed air.
- Never use open flames for lighting when working on the machine or checking for leaks.
- When carrying out checks with the engine running, request the assistance of an operator in the driver's seat. The operator must maintain visual contact with the service technician at all times.
- If operating outside the workshop, position the machine on a flat surface and lock in position. If working on a slope, lock the machine in position. Move to a flat area as soon as is safely possible.
- Maintenance and repair operations must be carried out in a clean and dry area. Clean up any water or oil spillage immediately.
- Do not create piles of oil or grease-soaked rags as they represent a serious fire hazard. Always store rags in a closed metal container.
- Before engaging the machine, make sure that there are no persons within the machine or implement range of action.
- Empty your pockets of all objects that may fall accidentally unobserved into the machine inner compartments.
- When metal parts are sticking out, use protective goggles or goggles with side guards, helmets, special footwear and gloves.
- When welding, use protective safety devices: tinted safety goggles, helmets, special overalls, gloves and footwear. All persons present in the area where welding is taking place must wear tinted goggles. **NEVER LOOK DIRECTLY AT THE WELDING ARC WITHOUT SUITABLE EYE PROTECTION.**



SERVICE MANUAL

Engine

CX5000 Elevation series Tier IV
CX6000 Elevation series Tier IV

Diesel Exhaust Fluid (DEF)/AdBlue® tank - Remove

NOTE: It is required to remove the rear right-hand side shield (1) to gain access to the DEF/AdBlue® tank. The shield (1) is secured to the machine frame at four locations (A), (B), (C) and (D).

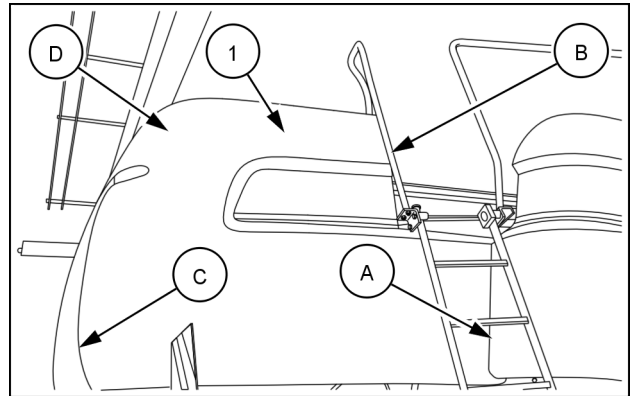

ZEIL14CXM0123AZ 1

NOTE: Access to some of the hardware is through the straw walker inspection cover (2).

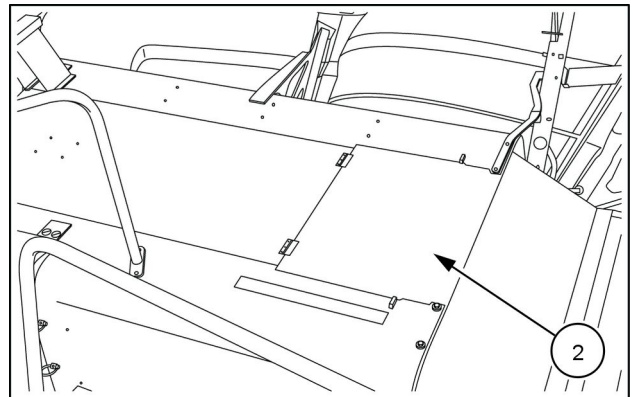

ZEIL14CXM0131AA 2

⚠ CAUTION

Heavy object!
The component is heavy. Use care not to drop the component when installing, removing, or handling.
Failure to comply could result in minor or moderate injury.

C0095A

1. Use a suitable hoist and secure the rear right-hand side shield (1).
2. Remove the hardware (3) and (4) from the rear right-hand side shield at the location (A) (see figure 1).

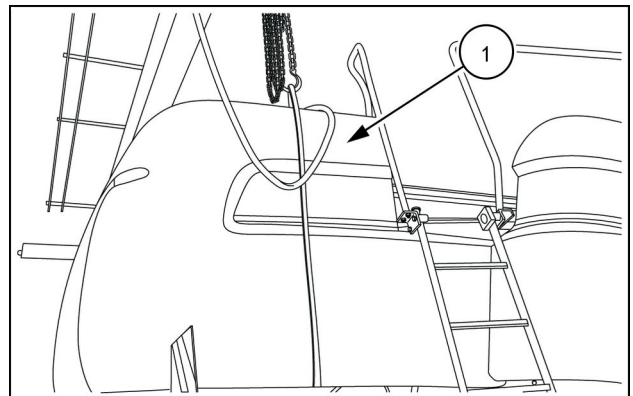

ZEIL14CXM0123AA 3

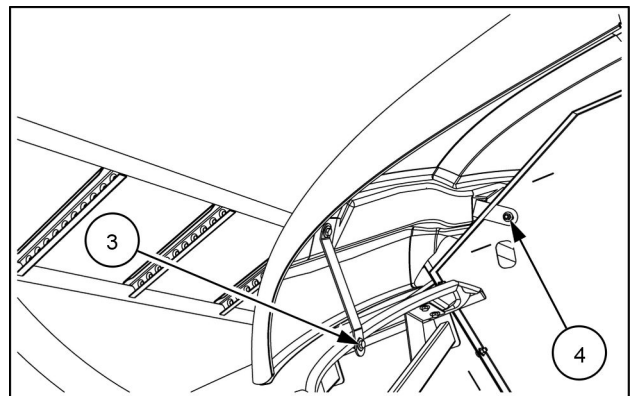

ZEIL14CXM0124AA 4

- Remove the hardware (5) and the cover plate (6) at the location (B) (see figure 1).

NOTE: Get access to the hardware (5) through the cover (2) (see figure 2).

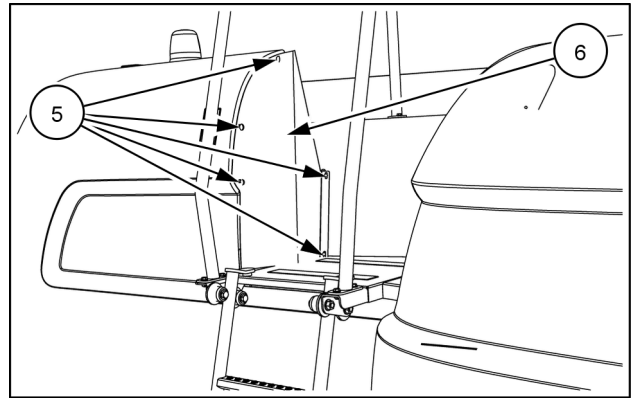

ZEIL14CXM0125AA 5

- Remove the hardware (7) from the rear right-hand side shield (1) at the location (C) (see figure 1).

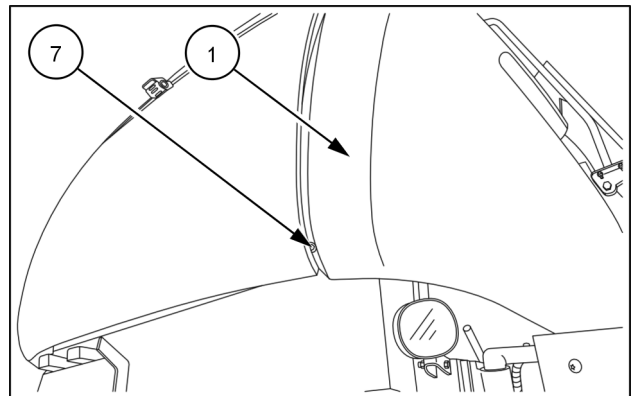

ZEIL14CXM0127AA 6

- Remove the hardware (8) from the rear right-hand side shield (1) at the location (D) (see figure 1).

- Remove the rear right-hand side shield (1).

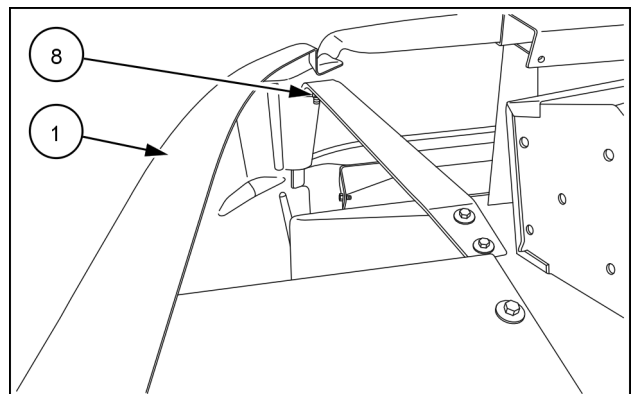

ZEIL14CXM0126AA 7

- On the DEF/AdBlue® tank (9), loosen the clamp (10) and remove the cover (11).

- Disconnect the DEF/AdBlue® line (12).

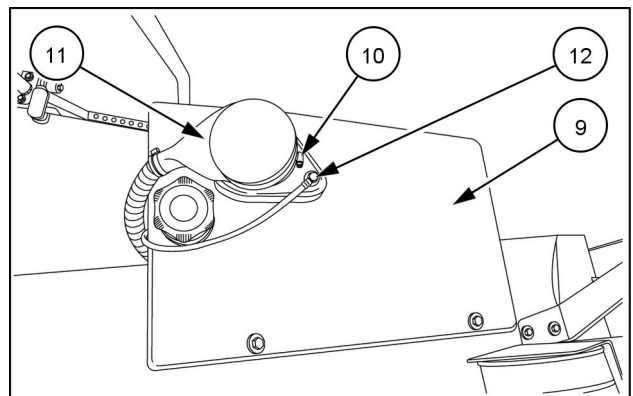

ZEIL14CXM0128AA 8



Suggest:

If the above button click is invalid.

Please download this document

first, and then click the above link

to download the complete manual.

Thank you so much for reading

9. Disconnect the electrical connector (13).
10. Mark and disconnect the DEF/AdBlue® lines (14) and (15).

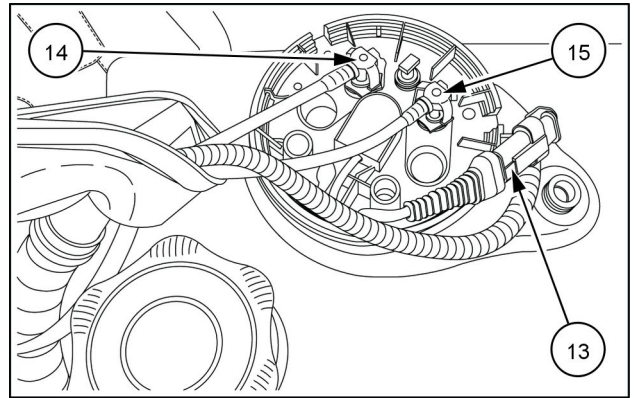

ZEIL14CXM0129AA 9

11. On the DEF/AdBlue® tank (9), remove the hardware (16).

NOTE: Get access to the hardware (16) through the straw walker inspection cover (2) (see figure 2).

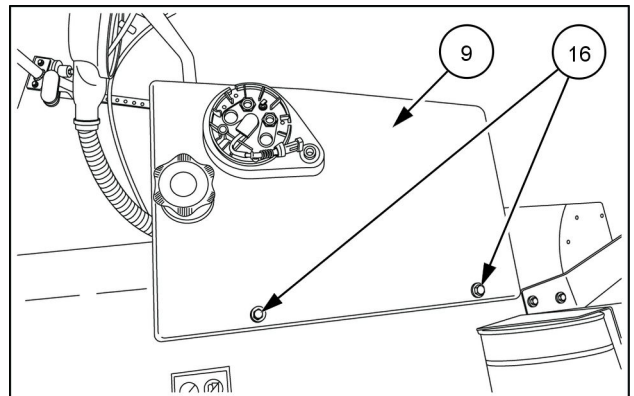

ZEIL14CXM0130AA 10

⚠ CAUTION

Heavy object!
 The component is heavy. Use care not to drop the component when installing, removing, or handling.
 Failure to comply could result in minor or moderate injury.

C0095A

12. Secure the DEF/AdBlue® tank (9) with a suitable forklift and slings.
13. Support the DEF/AdBlue® tank (9) and remove the hardware (17).
14. Slowly remove the DEF/AdBlue® tank (9) from the machine frame.

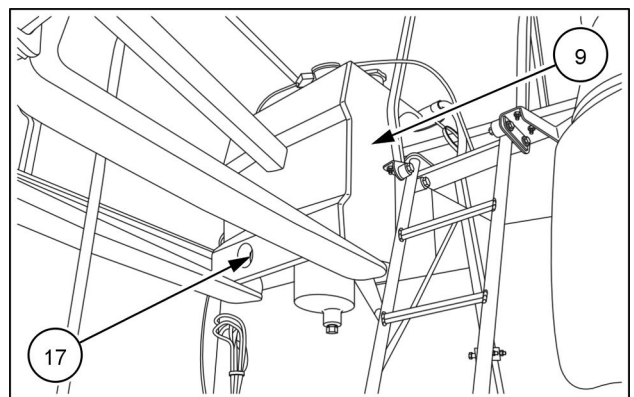

ZEIL14CXM0132AA 11

<https://www.ebooklibonline.com>

Hello dear friend!

Thank you very much for reading.

Enter the link into your browser.

The full manual is available for immediate download.

<https://www.ebooklibonline.com>