

SERVICE MANUAL

**T6.120 / T6.140 / T6.150 / T6.155 /
T6.160 / T6.165 / T6.175 /
T6.140 AutoCommand / T6.150 AutoCommand /
T6.160 AutoCommand
Tier 4A
Tractor**

Part number 47665870

English

March 2014

Replaces part number 47461584



Link Product / Engine

Product	Market Product	Engine
T6.140 AutoCommand	North America	F4DFE413C*A
T6.150 AutoCommand	North America	F4DFE413B*A
T6.160 AutoCommand	North America	F4DFE413A*A
T6.120	North America	F4DFE413E*A
T6.140	North America	F4DFE413C*A
T6.150	North America	F4DFE413B*A
T6.155	North America	F4DFE613F*A
T6.160	North America	F4DFE413A*A
T6.165	North America	F4DFE613E*A
T6.175	North America	F4DFE6132*A

Contents

INTRODUCTION

Engine	10
[10.001] Engine and crankcase	10.1
[10.216] Fuel tanks	10.2
[10.218] Fuel injection system.....	10.3
[10.202] Air cleaners and lines	10.4
[10.250] Turbocharger and lines.....	10.5
[10.254] Intake and exhaust manifolds and muffler	10.6
[10.500] Selective Catalytic Reduction (SCR) exhaust treatment.....	10.7
[10.400] Engine cooling system	10.8
[10.414] Fan and drive	10.9
[10.310] Aftercooler.....	10.10
Clutch	18
[18.112] Slip clutch or flywheel damper	18.1
Transmission	21
[21.112] Power shuttle transmission.....	21.1
[21.134] Power shuttle transmission external controls	21.2
[21.154] Power shuttle transmission internal components	21.3
[21.111] Semi-Powershift transmission	21.4
[21.133] Semi-Powershift transmission external controls	21.5
[21.103] Semi-Powershift transmission lubrication system.....	21.6
[21.152] Semi-Powershift transmission internal components	21.7
[21.504] Continuously Variable Transmission (CVT)	21.8
[21.505] Continuously Variable Transmission (CVT) external controls.....	21.9
[21.506] Continuously Variable Transmission (CVT) lubrication system	21.10
[21.507] Continuously Variable Transmission (CVT) internal components	21.11
[21.160] Creeper	21.12

<https://www.ebooklibonline.com>

Hello dear friend!

Thank you very much for reading.

Enter the link into your browser.

The full manual is available for immediate download.

<https://www.ebooklibonline.com>

[21.166] Overdrive	21.13
Four-Wheel Drive (4WD) system	23
[23.202] Electro-hydraulic control	23.1
[23.314] Drive shaft	23.2
Front axle system	25
[25.100] Powered front axle	25.1
[25.102] Front bevel gear set and differential	25.2
[25.108] Final drive hub, steering knuckles, and shafts	25.3
[25.122] Axle suspension control	25.4
Rear axle system	27
[27.100] Powered rear axle	27.1
[27.106] Rear bevel gear set and differential	27.2
[27.120] Planetary and final drives	27.3
Power Take-Off (PTO)	31
[31.104] Rear electro-hydraulic control	31.1
[31.114] Two-speed rear Power Take-Off (PTO)	31.2
[31.116] Three-speed rear Power Take-Off (PTO)	31.3
[31.142] Front Power Take-Off (PTO) control	31.4
[31.146] Front Power Take-Off (PTO)	31.5
Brakes and controls	33
[33.202] Hydraulic service brakes	33.1
[33.110] Parking brake or parking lock	33.2
[33.204] Front axle brake	33.3
[33.220] Trailer brake hydraulic control	33.4
[33.224] Trailer brake pneumatic control	33.5
Hydraulic systems	35
[35.000] Hydraulic systems	35.1

[35.300] Reservoir, cooler, and filters.....	35.2
[35.104] Fixed displacement pump.....	35.3
[35.106] Variable displacement pump.....	35.4
[35.105] Charge pump.....	35.5
[35.322] Regulated/Low pressure system.....	35.6
[35.204] Remote control valves.....	35.7
[35.220] Auxiliary hydraulic pump and lines.....	35.8
[35.114] Three-point hitch control valve.....	35.9
[35.116] Three-point hitch cylinder.....	35.10
[35.160] Front hitch controls and lines.....	35.11
Hitches, drawbars, and implement couplings.....	37
[37.120] Rear three-point hitch linkage.....	37.1
Frames and ballasting.....	39
[39.100] Frame.....	39.1
Steering.....	41
[41.101] Steering control.....	41.1
[41.106] Tie rods.....	41.2
[41.200] Hydraulic control components.....	41.3
[41.206] Pump.....	41.4
[41.216] Cylinders.....	41.5
Wheels.....	44
[44.511] Front wheels.....	44.1
[44.520] Rear wheels.....	44.2
Cab climate control.....	50
[50.100] Heating.....	50.1
[50.104] Ventilation.....	50.2
[50.200] Air conditioning.....	50.3
Electrical systems.....	55

- [55.000] Electrical system 55.1
- [55.100] Harnesses and connectors..... 55.2
- [55.015] Engine control system..... 55.3
- [55.301] Alternator..... 55.4
- [55.302] Battery..... 55.5
- [55.011] Fuel tank system 55.6
- [55.988] Selective Catalytic Reduction (SCR) electrical system 55.7
- [55.012] Engine cooling system 55.8
- [55.640] Electronic modules 55.9
- [55.513] Cab transmission controls..... 55.10
- [55.024] Transmission control system..... 55.11
- [55.020] Transmission speed sensors..... 55.12
- [55.021] Transmission pressure sensors 55.13
- [55.022] Transmission temperature sensors 55.14
- [55.023] Transmission position sensors 55.15
- [55.610] Ground speed control 55.16
- [55.048] Rear Power Take-Off (PTO) control system 55.17
- [55.031] Parking brake electrical system 55.18
- [55.035] Remote control valve electric control 55.19
- [55.051] Cab Heating, Ventilation, and Air-Conditioning (HVAC) controls..... 55.20
- [55.050] Heating, Ventilation, and Air-Conditioning (HVAC) control system..... 55.21
- [55.047] Steering control system 55.22
- [55.130] Rear three-point hitch electronic control system 55.23
- [55.911] Global Positioning System (GPS) 55.24
- [55.405] External lighting switches and relays 55.25
- [55.510] Cab or platform harnesses and connectors..... 55.26
- [55.408] Warning indicators, alarms, and instruments 55.27
- [55.DTC] FAULT CODES..... 55.28

Platform, cab, bodywork, and decals.....	90
[90.150] Cab.....	90.1
[90.100] Engine hood and panels	90.2



INTRODUCTION

Foreword

IMPORTANT INFORMATION

All repair and maintenance works listed in this manual must be carried out only by staff belonging to the NEW HOLLAND Service network, strictly complying with the instructions given and using, whenever required, the special tools.

Anyone who carries out the above operations without complying with the prescriptions shall be responsible for the subsequent damages.

The manufacturer and all the organizations of its distribution chain, including - without limitation - national, regional or local dealers, reject any responsibility for damages due to the anomalous behavior of parts and/or components not approved by the manufacturer himself, including those used for the servicing or repair of the product manufactured or marketed by the Manufacturer. In any case, no warranty is given or attributed on the product manufactured or marketed by the Manufacturer in case of damages due to an anomalous behavior of parts and/or components not approved by the Manufacturer.

No reproduction, though partial of text and illustrations allowed.

Foreword - How to use and navigate through this manual

This manual has been produced by a new technical information system. This new system is designed to deliver technical information electronically through web delivery (eTIM), DVD, and paper manuals. A coding system called SAP has been developed to link the technical information to other Product Support functions, e.g., Warranty.

Technical information is written to support the maintenance and service of the functions or systems on a customer's machine. When a customer has a concern on their machine it is usually because a function or system on their machine is not working at all, is not working efficiently, or is not responding correctly to their commands. When you refer to the technical information in this manual to resolve that customer's concern, you will find all the information classified using the SAP coding, according to the functions or systems on that machine. Once you have located the technical information for that function or system, you will then find all the mechanical, electrical or hydraulic devices, components, assemblies, and sub assemblies for that function or system. You will also find all the types of information that have been written for that function or system: the technical data (specifications), the functional data (how it works), the diagnostic data (fault codes and troubleshooting), and the service data (remove, install adjust, etc.).

By integrating SAP coding into technical information, you will be able to search and retrieve just the right piece of technical information you need to resolve that customer's concern on his machine. This is made possible by attaching 3 categories to each piece of technical information during the authoring process.

The first category is the Location, the second category is the Information Type and the third category is the Product:

- LOCATION - the component or function on the machine, that the piece of technical information is going to describe (e.g., Fuel tank).
- INFORMATION TYPE - the piece of technical information that has been written for a particular component or function on the machine (e.g., Capacity would be a type of Technical Data describing the amount of fuel held by the fuel tank).
- PRODUCT - the model for which the piece of technical information is written.

Every piece of technical information will have those three categories attached to it. You will be able to use any combination of those categories to find the right piece of technical information you need to resolve that customer's concern on their machine.

That information could be:

- the procedure for how to remove the cylinder head
- a table of specifications for a hydraulic pump
- a fault code
- a troubleshooting table
- a special tool

Safety rules

PRECAUTIONARY STATEMENTS

Personal Safety





This is the safety alert symbol. It is used to alert you to potential personal injury hazards. Obey all safety messages that follow this symbol to avoid possible injury or death.

Throughout this manual, you will find the signal words DANGER, WARNING, and CAUTION followed by special instructions. These precautions are intended for the personal safety of you and those working with you.

Read and understand all the safety messages in this manual before you operate or service the machine.

 DANGER indicates a hazardous situation which, if not avoided, will result in death or serious injury.

 WARNING indicates a hazardous situation which, if not avoided, could result in death or serious injury.

 CAUTION, used with the safety alert symbol, indicates a hazardous situation which, if not avoided, could result in minor or moderate injury.

FAILURE TO FOLLOW DANGER, WARNING, AND CAUTION MESSAGES COULD RESULT IN DEATH OR SERIOUS INJURY.

NOTICE: Install new decals if the old decals are destroyed, lost painted over or cannot be read. When parts are replaced that have decals make sure you install a new decal with each new part.

MACHINE SAFETY

NOTICE: Notice indicates a situation which, if not avoided, could result in machine or property damage.

Throughout this manual you will find the signal word Notice followed by special instructions to prevent machine or property damage. The word Notice is used to address practices not related to personal safety.

INFORMATION

NOTE: Note indicates additional information which clarifies steps, procedures, or other information in this manual.

Throughout this manual you will find the word Note followed by additional information about a step, procedure, or other information in the manual. The word Note is not intended to address personal safety or property damage.

ACCIDENT PREVENTION

▲ WARNING

Avoid injury! Always do the following before lubricating, maintaining, or servicing the machine.

- 1. Disengage all drives.**
 - 2. Engage parking brake.**
 - 3. Lower all attachments to the ground, or raise and engage all safety locks.**
 - 4. Shut off engine.**
 - 5. Remove key from key switch.**
 - 6. Switch off battery key, if installed.**
 - 7. Wait for all machine movement to stop.**
- Failure to comply could result in death or serious injury.**

W0047A

Most accidents or injuries that occur in workshops are the result of non compliance to simple and fundamental safety principles. For this reason, IN MOST CASES THESE ACCIDENTS CAN BE AVOIDED by applying the fundamental safety principles, acting with the necessary caution and care.

Accidents may occur with all types of machine, regardless of how well the machine in question was designed and built.

SAFETY REQUIREMENTS FOR FLUID POWER SYSTEMS AND COMPONENTS - HYDRAULICS (EUROPEAN STANDARD EN982)

- Flexible hose assemblies must not be constructed from hoses which have been previously used as part of a hose assembly.
- Do not weld hydraulic pipes: when flexible hoses or piping are damaged, replace them immediately.
- It is forbidden to modify a hydraulic accumulator by machining, welding or any other way.
- Before removing hydraulic accumulators for servicing, the liquid pressure in the accumulators must be reduced to zero.
- Pressure check on hydraulic accumulators must be carried out by a method recommended by the accumulator manufacturer.
- Take care not to exceed the maximum allowed pressure of the accumulator. After any check or adjustment, check for leakages or gas in the hoses or pipes.

SAFETY RULES

General guidelines

- Carefully follow specified repair and maintenance procedures.
- When appropriate, use P.P.E (Personal Protective Equipment)
- Do not wear rings, wristwatches, jewellery, unbuttoned or loose articles of clothing such as: ties, torn clothing, scarves, open jackets or shirts with open zips that may remain entangled in moving parts. It is advised to wear approved safety clothing, e.g.: non-slip footwear, gloves, safety goggles, helmets, etc.
- Do not carry out repair operations with someone sitting in the driver's seat, unless the person is a trained technician who is assisting with the operation in question.
- Do not operate the machine or use any of the implements from different positions, other than the driver's seat.
- Do not carry out operations on the machine with the engine running, unless specifically indicated.
- Bring all hydraulic cylinders to the home positions (down, retracted, etc.) before engine shut down.
- Stop the engine and check that the hydraulic circuits are pressure-free before removing caps, covers, valves, etc.
- All repair and maintenance operations must be carried out using extreme care and attention.
- Service steps and platforms used in the workshop or elsewhere should be built according to the applicable standards and legislation.
- Disconnect the power take off (p.t.o). and label the controls to indicate that the machine is being serviced. Any parts that are to be raised must be locked in position.



SERVICE MANUAL

Engine

**T6.120 , T6.140 AutoCommand , T6.140 , T6.150 AutoCommand , T6.150 ,
T6.155 , T6.160 AutoCommand , T6.160 , T6.165 , T6.175**

Engine - Disconnect

T6.155	NA
T6.165	NA
T6.175	NA

Prior operation:

Discharge the Air conditioning system, for further information refer to **Air conditioning - Discharging (50.200)**

Prior operation:

Disconnect battery, for further information refer to **Battery - Disconnect (55.302)**

Prior operation:

Drain the engine coolant system, for further information refer to **Engine cooling system - Drain fluid (10.400)**

Prior operation:

Remove the selective catalytic reduction (SRC) muffler, for further information refer to **Selective Catalytic Reduction (SCR) muffler and catalyst - Remove (10.500)**

Prior operation:

Remove the selective catalytic reduction (SRC) coolant control valve, for further information refer to **Coolant control valve - Remove (10.500)**

⚠ WARNING

Heavy objects!

Lift and handle all heavy components using lifting equipment with adequate capacity. Always support units or parts with suitable slings or hooks. Make sure the work area is clear of all bystanders.

Failure to comply could result in death or serious injury.

W0398A

⚠ WARNING

Avoid injury!

Handle all parts carefully. Do not place your hands or fingers between parts. Use Personal Protective Equipment (PPE) as indicated in this manual, including protective goggles, gloves, and safety footwear.

Failure to comply could result in death or serious injury.

W0208A

1. Using suitable lifting equipment support the front weights.

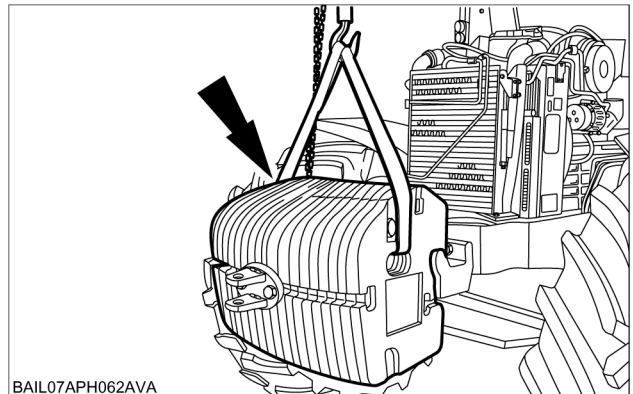

BAIL07APH062AVA

BAIL07APH062AVA 1

2. Disconnect and remove the front weights from the weight carrier.

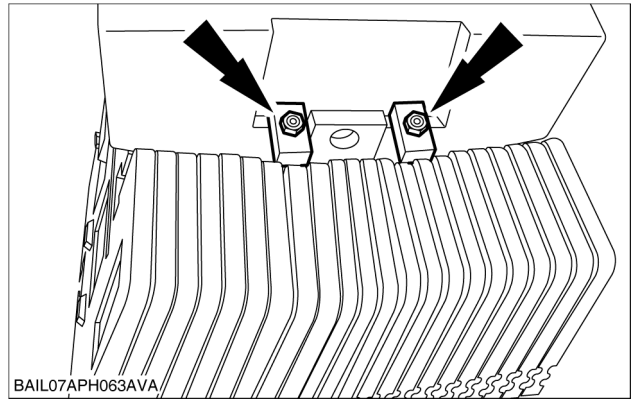

BAIL07APH063AVA 2

3. Disconnect the radar electrical connector and remove the radar (if fitted).

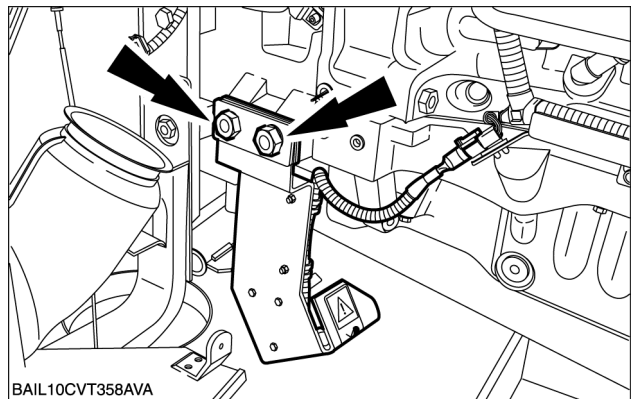

BAIL10CVT358AVA 3

4. Remove the flywheel speed sensor.

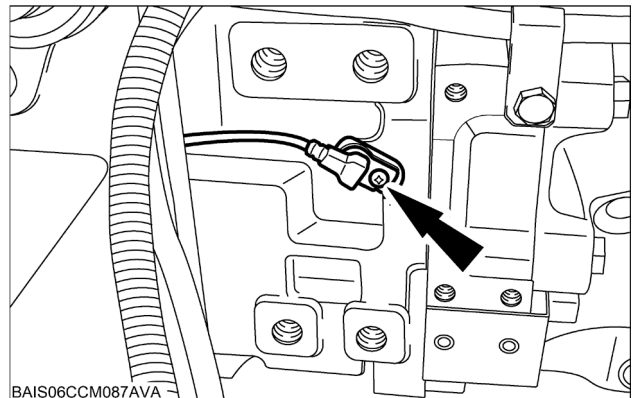

BAIS06CCM087AVA 4

5. Disconnect the engine harness electrical connectors.

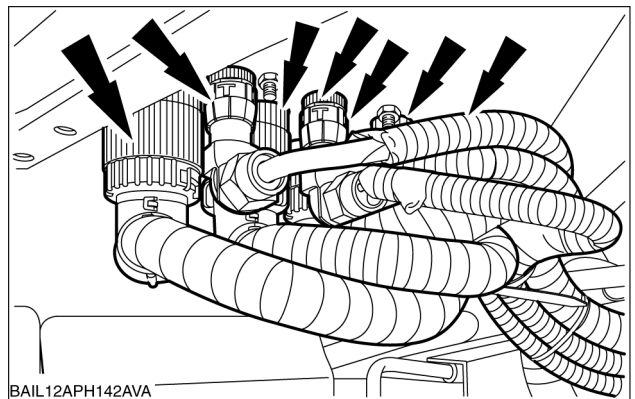

BAIL12APH142AVA 5

6. Detach the cab heater return pipe.

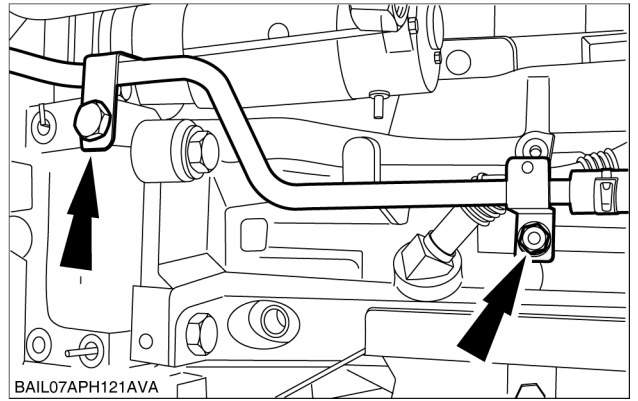

BAIL07APH121AVA 6

7. Disconnect the oil cooler supply pipes.

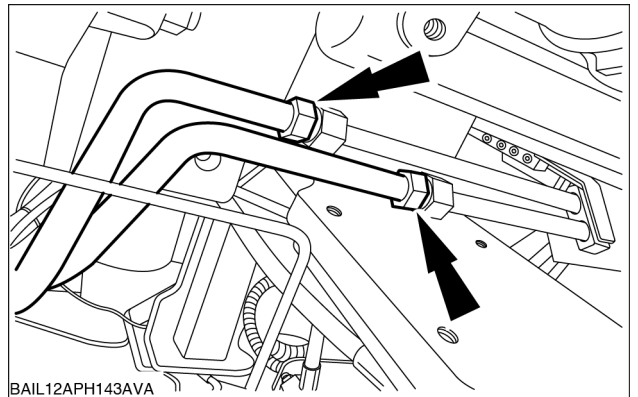

BAIL12APH143AVA 7

8. Disconnect the oil cooler supply and return pipes (1).
Remove the oil cooler pipes (2).

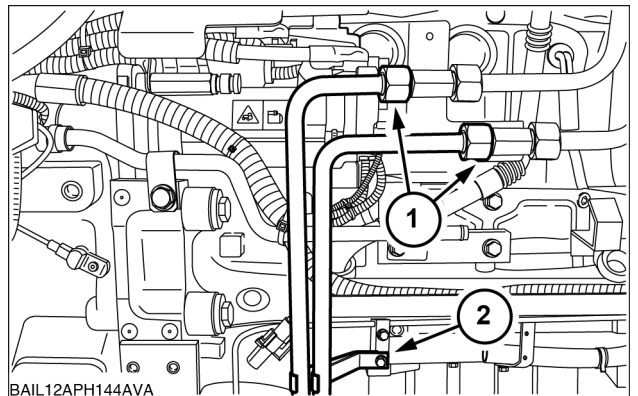

BAIL12APH144AVA 8

9. Disconnect the heater supply hose from the rear of the engine cylinder head.

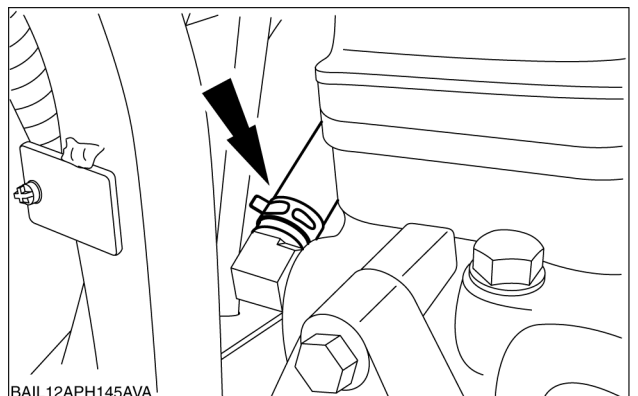

BAIL12APH145AVA 9



Suggest:

If the above button click is invalid.

Please download this document

first, and then click the above link

to download the complete manual.

Thank you so much for reading

10. Remove the starter motor heat shield.

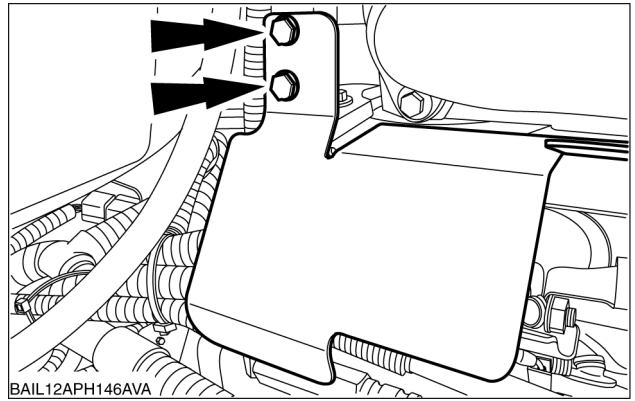

BAIL12APH146AVA

BAIL12APH146AVA 10

11. Remove the starter motor cover.

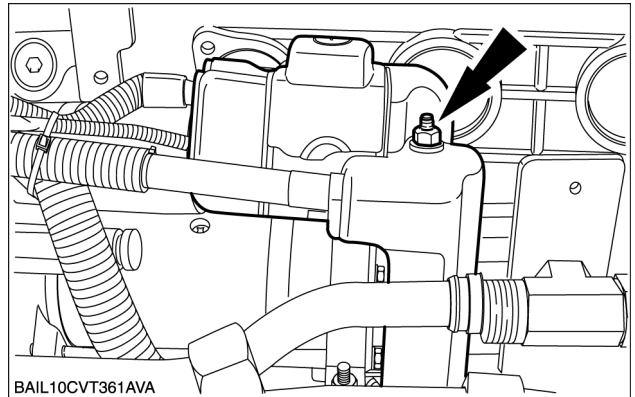

BAIL10CVT361AVA

BAIL10CVT361AVA 11

12. Disconnect the starter motor electrical connector.

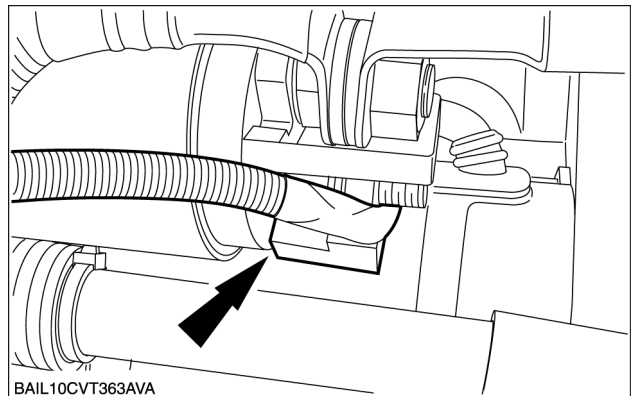

BAIL10CVT363AVA

BAIL10CVT363AVA 12

13. Disconnect the positive terminal (1), negative terminal (2) relay and bracket (3) and position to one side.

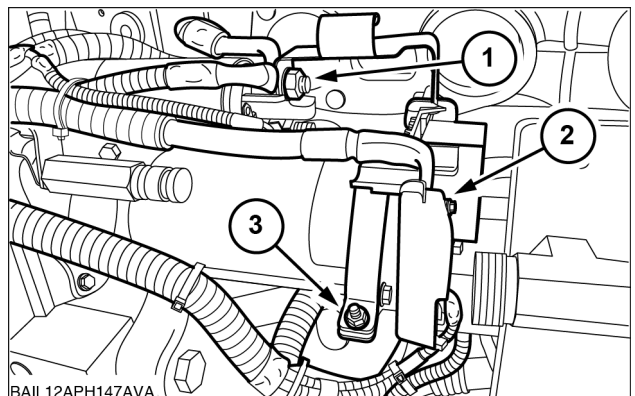

BAIL12APH147AVA

BAIL12APH147AVA 13

<https://www.ebooklibonline.com>

Hello dear friend!

Thank you very much for reading.

Enter the link into your browser.

The full manual is available for immediate download.

<https://www.ebooklibonline.com>