

SERVICE MANUAL

T5.95 / T5.105
T5.115
Tractor

Part number 84568014
English
March 2013





SERVICE MANUAL

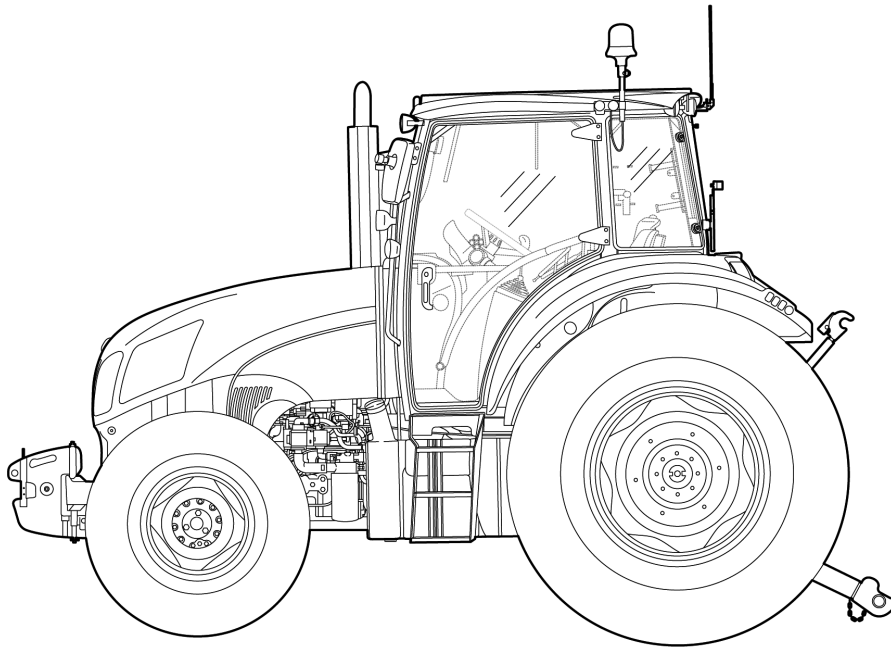

T5.105

T5.115

T5.95

Link Product / Engine

Product	Market Product	Engine
T5.105	Europe	F5DFL413B*A006
T5.105	North America	F5DFL413B*A006
T5.105	International Region	F5DFL413B*A006
T5.115	North America	F5DFL413A*A002
T5.115	International Region	F5DFL413A*A002
T5.115	Europe	F5DFL413A*A002
T5.95	Europe	F5DFL413C*A003
T5.95	International Region	F5DFL413C*A003
T5.95	North America	F5DFL413C*A003

<https://www.ebooklibonline.com>

Hello dear friend!

Thank you very much for reading.

Enter the link into your browser.

The full manual is available for immediate download.

<https://www.ebooklibonline.com>

Contents

INTRODUCTION

Engine	10
[10.001] Engine and crankcase	10.1
[10.414] Fan and drive	10.2
[10.501] Exhaust Gas Recirculation (EGR) - Diesel Particulate Filter (DPF) exhaust treatment	10.3
Clutch	18
[18.112] Slip clutch or flywheel damper	18.1
Transmission	21
[21.118] Transmission/Rear drive	21.1
[21.112] Power shuttle transmission.....	21.2
[21.104] Power shuttle transmission lubrication system.....	21.3
[21.134] Power shuttle transmission external controls	21.4
[21.148] Transmission/Rear drive internal components	21.5
[21.154] Power shuttle transmission internal components	21.6
[21.145] Gearbox internal components.....	21.7
[21.160] Creeper	21.8
[21.168] Hi-Lo unit.....	21.9
Four-Wheel Drive (4WD) system	23
[23.202] Electro-hydraulic control	23.1
[23.304] Four-Wheel Drive (4WD) gearbox	23.2
[23.314] Drive shaft.....	23.3
Front axle system	25
[25.100] Powered front axle	25.1
[25.102] Front bevel gear set and differential	25.2
[25.108] Final drive hub, steering knuckles, and shafts	25.3
Rear axle system	27

[27.100] Powered rear axle.....	27.1
[27.106] Rear bevel gear set and differential.....	27.2
[27.120] Planetary and final drives	27.3
Power Take-Off (PTO).....	31
[31.104] Rear electro-hydraulic control.....	31.1
[31.116] Three-speed rear Power Take-Off (PTO)	31.2
[31.114] Two-speed rear Power Take-Off (PTO)	31.3
Brakes and controls	33
[33.202] Hydraulic service brakes	33.1
[33.204] Front axle brake	33.2
[33.110] Parking brake or parking lock	33.3
[33.220] Trailer brake hydraulic control.....	33.4
Hydraulic systems.....	35
[35.000] Hydraulic systems.....	35.1
[35.355] Hydraulic hand control	35.2
[35.204] Remote control valves	35.3
[35.114] Three-point hitch control valve	35.4
Hitches, drawbars, and implement couplings.....	37
[37.110] Rear three-point hitch	37.1
Steering.....	41
[41.200] Hydraulic control components.....	41.1
[41.206] Pump	41.2
[41.216] Cylinders	41.3
Wheels.....	44
[44.511] Front wheels.....	44.1
Electrical systems.....	55
[55.000] Electrical system	55.1

[55.100] Harnesses and connectors.....	55.2
[55.201] Engine starting system.....	55.3
[55.301] Alternator.....	55.4
[55.302] Battery.....	55.5
[55.640] Electronic modules.....	55.6
[55.024] Transmission control system.....	55.7
[55.523] Cab hitch controls.....	55.8
[55.130] Rear three-point hitch electronic control system.....	55.9
[55.408] Warning indicators, alarms, and instruments.....	55.10
[55.DTC] FAULT CODES.....	55.11
Platform, cab, bodywork, and decals.....	90
[90.150] Cab.....	90.1
[90.100] Engine hood and panels.....	90.2



INTRODUCTION

Advice

IMPORTANT NOTICE

All maintenance and repair work described in this manual must be performed exclusively by NEW HOLLAND AGRICULTURE service technicians, in strict accordance with the instructions given and using any specific tools necessary. Anyone performing the operations described herein without strictly following the instructions is personally responsible for any eventual injury or damage to property.

Safety rules SAFETY REGULATIONS

TO PREVENT ACCIDENTS

Most accidents or injuries that occur in workshops are the result of non-observance of simple and fundamental safety regulations.

For this reason, IN MOST CASES THESE ACCIDENTS CAN BE AVOIDED: by foreseeing possible causes and consequently acting with the necessary caution and care.

Accidents may occur with all types of vehicle, regardless of how well it was designed and built.

A careful and judicious service technician is the best guarantee against accidents.

Precise observance of the most basic safety rule is normally sufficient to avoid many serious accidents.

DANGER: Never carry out any cleaning, lubrication or maintenance operations when the engine is running.

GENERAL

- Carefully follow specified repair and maintenance procedures.
- Do not wear rings, wristwatches, jewellery, unbuttoned or loose articles of clothing such as: ties, torn clothing, scarves, open jackets or shirts with open zips that may remain entangled in moving parts.
It is advised to wear approved safety clothing, e.g: non-slip footwear, gloves, safety goggles, helmets, etc.
- Do not carry out repair operations with someone sitting in the driver's seat, unless the person is a trained technician who is assisting with the operation in question.
- Operate the vehicle and use the implements exclusively from the driver's seat.
- Do not carry out operations on the vehicle with the engine running, unless specifically indicated.
- Stop the engine and ensure that all pressure is relieved from hydraulic circuits before removing caps, covers, valves, etc.
- All repair and maintenance operations must be carried out using extreme care and attention.
- Service steps and platforms used in a workshop or in the field should be built in compliance with the safety rules in force.
- Disconnect the batteries and label all controls to indicate that the vehicle is being serviced. Block the machine and all equipment which should be raised.
- Do not check or fill fuel tanks, accumulator batteries, nor use starting liquid when smoking or near naked flames, as these fluids are inflammable.
- Brakes are inoperative if manually released for repair or maintenance purposes.
In such cases, the machine should be kept constantly under control using blocks or similar devices.
- The fuel nozzle should always be in contact with the filling aperture. Maintain this position until filling operations are completed in order to avoid possible sparks caused by the accumulation of static electricity.
- Only use specified towing points for towing the tractor, connect parts carefully. Make sure that all pins and/or locks are secured in position before applying traction.
Never remain near the towing bars, cables or chains that are operating under load
- Transport vehicles that cannot be driven using a trailer or a low-loading platform trolley, if available.
- When loading or unloading the vehicle from the trailer (or other means of transport), select a flat area capable of sustaining the trailer or truck wheels, firmly secure the tractor to the truck or trailer and lock the wheels in the position.
- Electric heaters, battery-chargers and similar equipment must only be powered by auxiliary power supplies with efficient ground insulation to avoid electrical shock hazards.
- Always use suitable hoisting or lifting devices when raising or moving heavy parts.
- Take extra care if bystanders are present.
- Never pour gasoline or diesel oil into open, wide and low containers.
- Never use gasoline, diesel oil or other inflammable liquids as cleaning agents. Use non-flammable non-toxic proprietary solvents.
- Wear safety goggles with side guards when cleaning parts with compressed air.
- Limit the air pressure to a maximum of **2.1 bar (30.5 psi)**, according to local regulations.

- Do not run the engine in confined spaces without suitable ventilation.
- Do not smoke, use naked flames, or cause sparks in the area when fuel filling or handling highly inflammable liquids.
- Never use naked flames for lighting when working on the machine or checking for leaks.
- All movements must be carried out carefully when working under, on or near the vehicle and wear protective equipment: helmets, goggles and special footwear.
- When carrying out checks with the engine running, request the assistance of an operator in the driver's seat. The operator must maintain visual contact with the service technician at all times.
- If operating outside the workshop, position the vehicle on a flat surface and lock in position. If working on a slope, lock the vehicle in position and move to a flat area as soon as is safely possible.
- Damaged or bent chains or cables are unreliable. Do not use them for lifting or towing. Always use suitable protective gloves when handling chains or cables.
- Chains should always be safely secured. Ensure that fastening device is strong enough to hold the load foreseen. No persons should stop near the fastening point, trailing chains or cables.
- Maintenance and repair operations must be carried out in a CLEAN and DRY area, eliminate any water or oil spillage immediately.
- Do not create piles of oil or grease--soaked rags as they represent a serious fire hazard; store them in a closed metal container. Before starting the vehicle or implements, make sure that the driver's seat is locked in position and always check that the area is free of persons or obstacles.
- Empty pockets of all objects that may fall unobserved into the vehicle parts when disassembled.
- In the presence of protruding metal parts, use protective goggles or goggles with side guards, helmets, special footwear and gloves.
- Handle all parts carefully, do not put your hands or fingers between moving parts, wear suitable safety clothing -- safety goggles, gloves and shoes.

WELDING OPERATIONS

- When welding, use protective safety devices: tinted safety goggles, helmets, special overalls, gloves and footwear. All persons present in the area where welding is taking place must wear tinted goggles. NEVER LOOK AT THE WELDING ARC IF YOUR EYES ARE NOT SUITABLY PROTECTED.
- Where possible, remove the part or tool that requires arc welding from the tractor.
- Disconnect both battery leads. Isolate the cable ends to avoid contact with each other and the tractor.
- Position the welder ground clamp as near as possible to the area where welding is taking place.
- Remove the electronic control units located on the tractor if welding is to be carried out near these control units.
- Never allow welding cables to lay on, near or across any electrical wiring or electronic component while welding is in progress.
- Metal cables tend to fray with repeated use. Always use suitable protective devices (gloves, goggles, etc.) when handling cables.

START UP

- Never start the engine in confined spaces that are not equipped with adequate ventilation for exhaust gas extraction.
- Never place the head, body, limbs, feet, hands or fingers near fans or rotating belts.

ENGINE

- Always loosen the radiator cap slowly before removing it to allow any remaining pressure in the system to be discharged. Coolant should be topped up only when the engine is stopped or idle if hot.
- Never fill up with fuel when the engine is running, especially if hot, in order to prevent the outbreak of fire as a result of fuel spillage
- Never check or adjust fan belt tension when the engine is running. Never adjust the fuel injection pump when the vehicle is moving.



SERVICE MANUAL

Engine

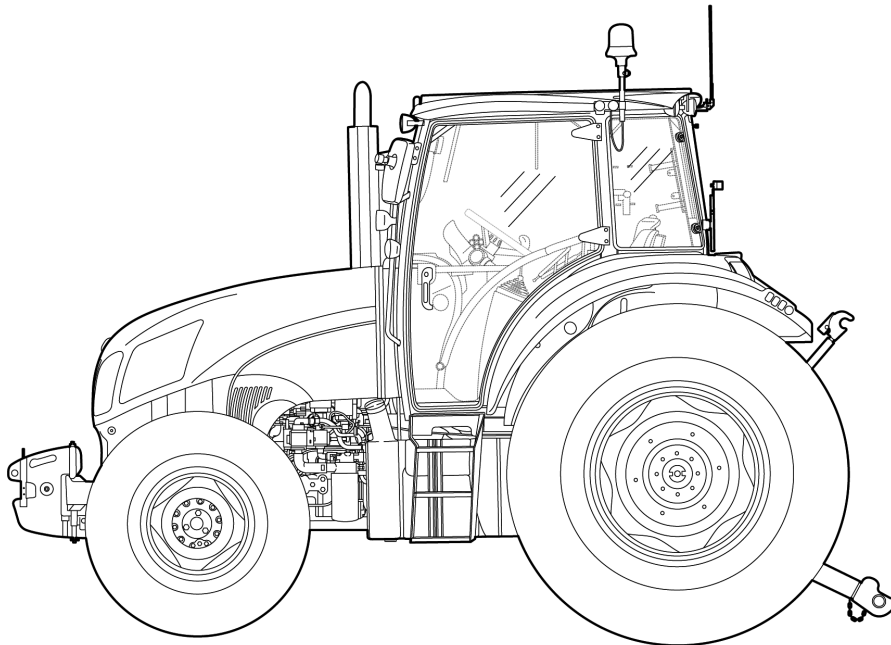

T5.105
T5.115
T5.95

Engine - General specification

GENERAL SPECIFICATIONS	4 Cylinders
Engine, technical type: T5.95 T5.105 T5.115	F5DFL413C*A003 F5DFL413B*A006 F5DFL413B*A002
Engine rpm - high - nominal - low	2400 - 2500 RPM 2300 RPM 700 - 800 RPM
Cycle	diesel, 4-stroke
Fuel injection	Direct
Number of cylinders in line	4
Bore - All models - Piston diameter - Piston stroke	99 mm (3.8976 in) 110 mm (4.3307 in)
Total displacement: - All models	3400 cm³
Compression ratio All models	17 ± 0.5 : 1
Maximum Power Output: - T5.95 - T5.105 - T5.115 Maximum power speed	73 kW (99 Hp) 79 kW (107 Hp) 84 kW (114 Hp) 2300 RPM
Peak torque - T5.95 - T5.105 - T5.115 Peak torque speed	407 N·m (300.19 lb ft) 444 N·m (327.48 lb ft) 461 N·m (340.02 lb ft) 1500 RPM
Torque increase - T5.95 - T5.105 - T5.115	34 % 35 % 32 %
Power at the power take-off - T5.95 - T5.105 - T5.115	62.7 kW (85.1 Hp) 68.6 kW (93.3 Hp) 73.9 kW (100.4 Hp)
Number of main bearings	5
Sump	structural, cast iron
Lubrication	forced, with lobe pump
Pump drive	from crankshaft
Oil filtration	mesh screen on oil intake and filter cartridge on delivery line
Engine oil pressure switch operating pressures: - contacts closing* with decreasing pressure. - contacts opening* with increasing pressure. * with the contacts closed the engine oil pressure warning light is on	0.2 bar (2.90 psi) 0.9 bar (13.05 psi)
Cooling	coolant circulation
closing	with five rows of vertical pipes
Capacity	16 l (4.23 US gal)
Fan with viscous joint, fixed to the specific pulley	ø 520 mm (20.4724 in)
Coolant pump	intake, in plastic with 10 blades
Coolant thermometer	colored scale divided into three sections
Temperature ranges corresponding to each section: - initial dark blue sector - final red sector	normal temperature high temperature
dark blue area - Start of opening	via thermostat valve 80 °C (176.00 °F)

Engine - Engine and crankcase

GENERAL SPECIFICATIONS	4 Cylinders
Timing	overhead valves operated by tappets, rods and rocker arms via the camshaft located in the engine block; the camshaft is driven by the crankshaft using straight-tooth gears
Intake: - start: before P.M.S. - end: after P.M.I.	<p style="text-align: right;">19 ° 37 °</p>
Exhaust: - start: before P.M.I. - end: after P.M.S.	<p style="text-align: right;">61 ° 21 °</p>
Clearance between valves and rocker arms with engine cold.	The valve clearance is hydraulically controlled. Therefore, manual adjustment is not necessary.
Turbocharging	Turbocharged with intercooler
Air cleaning	dual cartridge dry air cleaner, with clogged filter indicator with centrifugal pre-filter and automatic dust ejector
Fuel filtration	by mesh prefilter on the supply pipe, suction line filter with water - fuel separator, low pressure filter and sensor.
Priming pump Injection pump Type Nozzles type Injection pressure	<p style="text-align: center;">Manual mounted on the suction line filter BOSCH High pressure Common Rail control unit HPCR - CP4.1 Electro-injectors 300 - 1400 bar (4350.00 - 20300.00 psi)</p>
Filling: Engine sump Fuel tank	<p style="text-align: center;">6.4 - 8.1 l (1.69 - 2.14 US gal) 140 l (36.98 US gal)</p>
Anti-pollution system Type:	<p style="text-align: center;">Exhaust gas recycling system EGR Particulate filter DPF*</p>
Recommended frequency for renewing filter	every 3000 hours

NOTE: * - For filter maintenance please refer to: (**Diesel Particulate Filters (DPF) - Dynamic description manual regeneration of the diesel particulate filter (DPF) (55.408)**)

Engine - Remove

1. Remove the hood (1) as indicated in **Hood - Remove (90.100)**
2. Free the bottom steps of the ladder with the retainer (1), raise it with the knob (2), take off the battery cover, detach the battery negative cable.

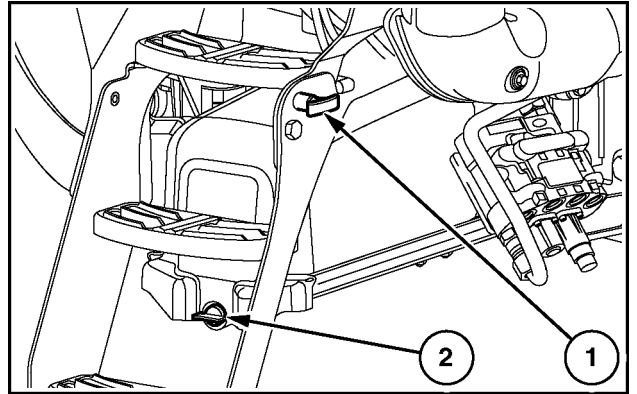

WLAPL4S10C101A 1

3. Remove the split pins, retaining pin and front ballast assembly (1) from the support.

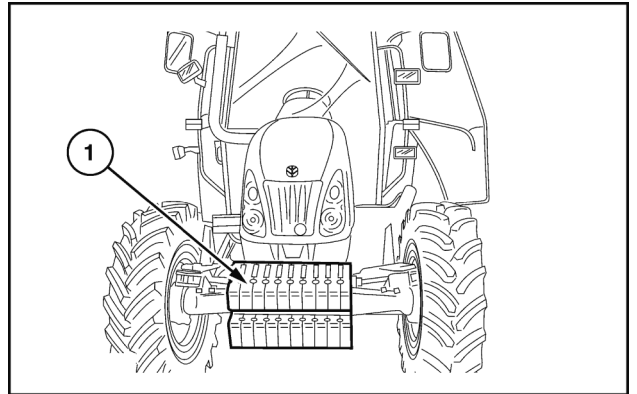

WLAPL4S10C103A 2

4. Unscrew the fixing screws (1) and remove the front wheel mudguards (2) (if applicable) Do this on both sides.

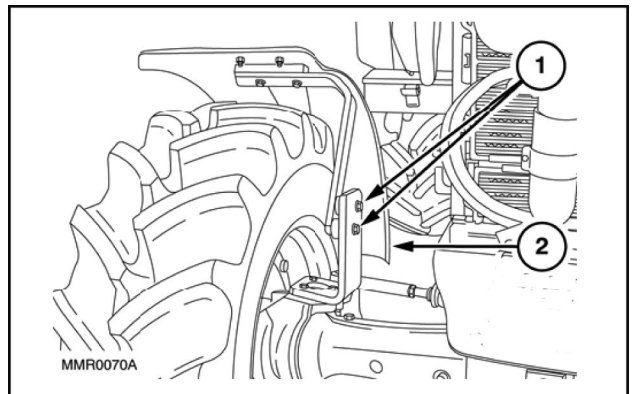

WLAPL4S10C104A 3

5. Remove the fixing bolts (1) and detach the engine left-hand side panel (2). Carry out the same operation for the right-hand side panel too. Remove the glove compartment.

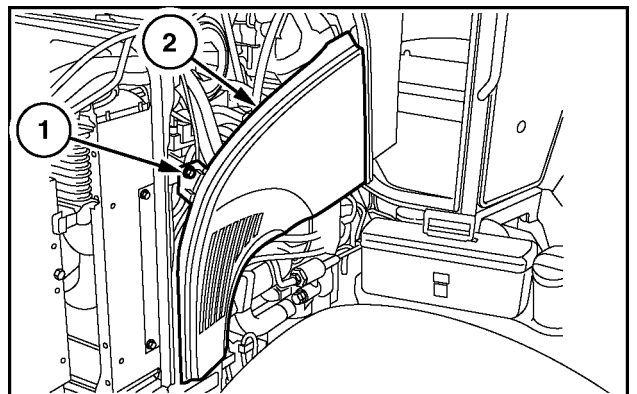

WLAPL4S10C105A 4

6. Recover the refrigerant from the system via the connections (1) and (2) using the specific tool **380000315**. Detach the pipe (1), clear the section of brackets and clamps, move it onto the condenser (1), (6), detach the pipe (2), clear the section and take it to the cab.

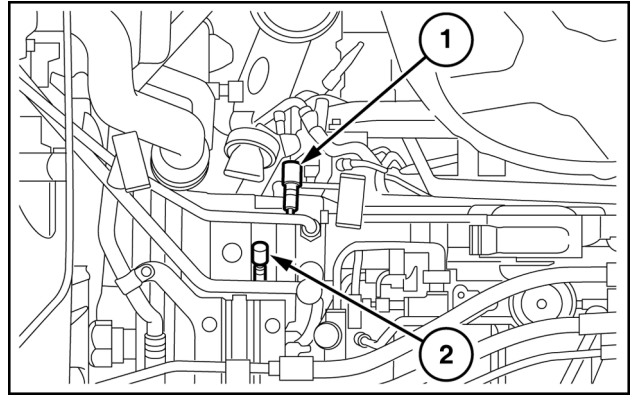

WLAPL4S10C106AA 5

7. Subsequently go onto the front detach the lower pipe (3) on the condenser (1) free it from any straps or clamps, disconnect the sensor (2) and take it to the cab.

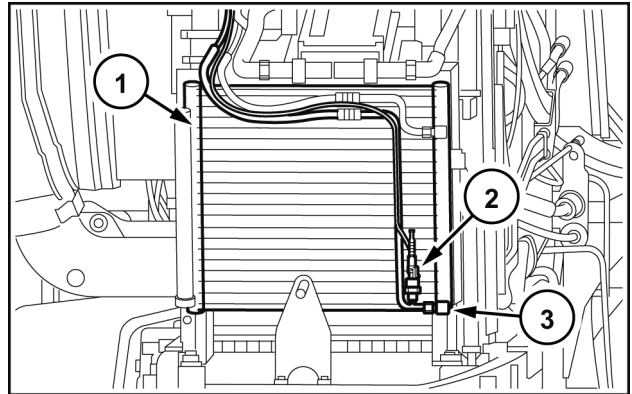

WLAPL4S10C107A 6

8. Drain the fuel from the tank by removing the bottom drain plug.

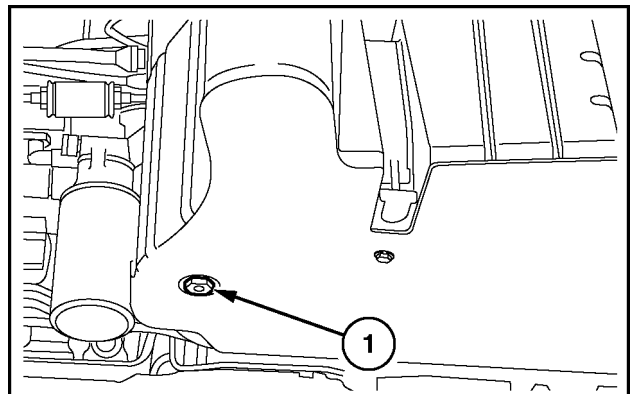

WLAPL4S10C108A 7

9. Unscrew the fixing bolts (1) and remove the right-hand steps (2).

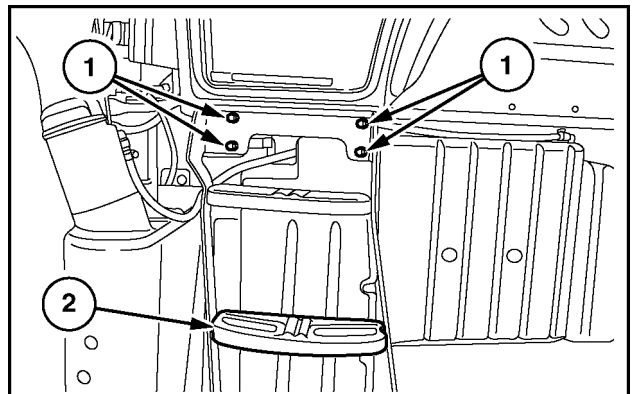

WLAPL4S10C109A 8

10. Raise the rear of the tractor with a hydraulic jack, put a mechanical stand under the reduction unit box, with a pneumatic gun remove the left-hand rear wheel retaining nuts, and subsequently take off the wheel.

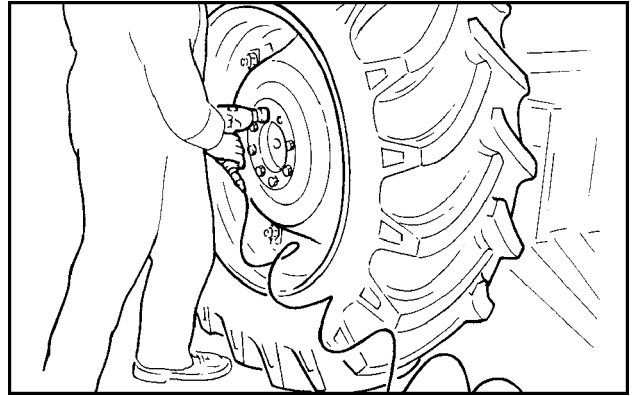

WLAPL4S10C110A 9

11. Detach the tank retaining straps (1), mark and detach the fuel pipes (2) and extract the fuel tank (3). Remove also the bottom tank guard (4)

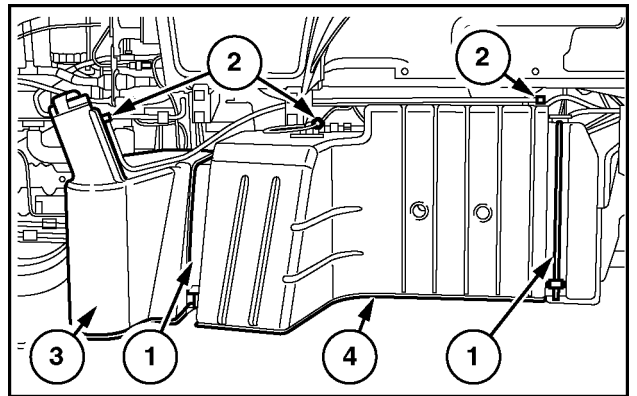

WLAPL4S10C111A 10

12. Unscrew the front central and rear retaining bolts on the front axle shaft guard, then remove the guard (1).

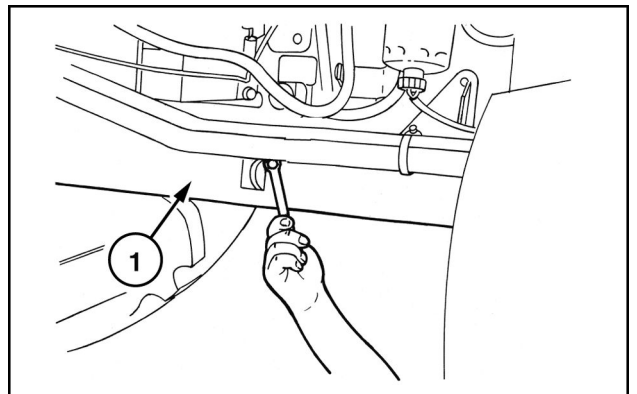

WLAPL4S10C112AA 11

13. Remove the circlip (2) and move the front sleeve (1) in the direction indicated by the arrow until it is released from the groove on the front axle.

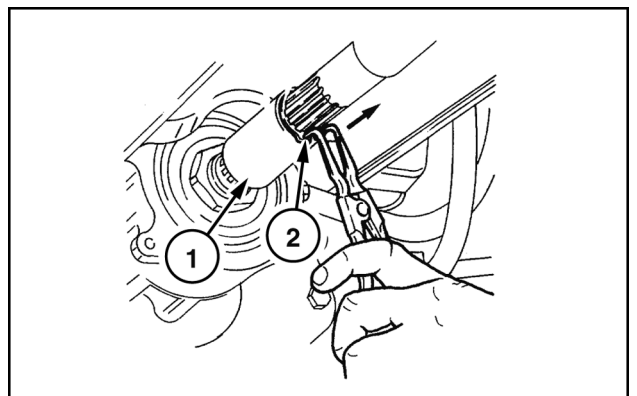

WLAPL4S10C113AA 12



Suggest:

If the above button click is invalid.

Please download this document

first, and then click the above link

to download the complete manual.

Thank you so much for reading

14. Remove the circlip (2) retaining the coupling sleeve of the propeller shaft (1) on the back, move the sleeve on the shaft.

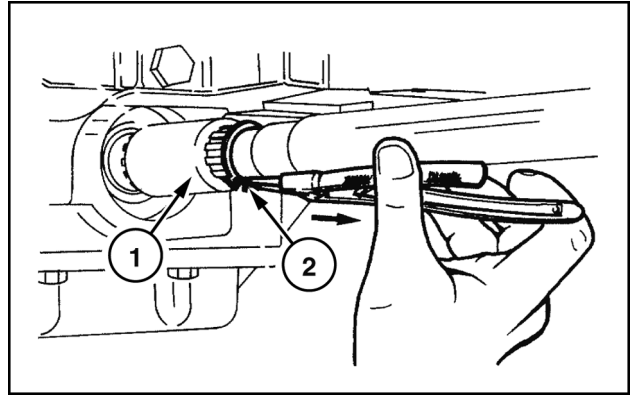

WLAPL4S10C114AA 13

15. Take out the screws fixing the central support (1) of the propeller shaft and remove the shaft together with the support, remove also the shaft end float adjuster shim on the back.

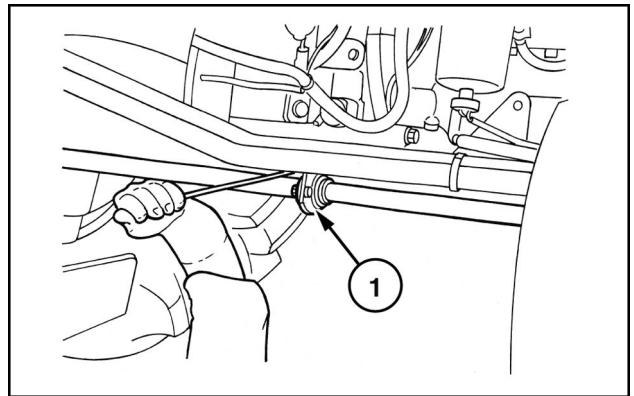

WLAPL4S10C115AA 14

16. Loosen the union of the cab heater radiator coolant return pipe, drain and collect the engine coolant.

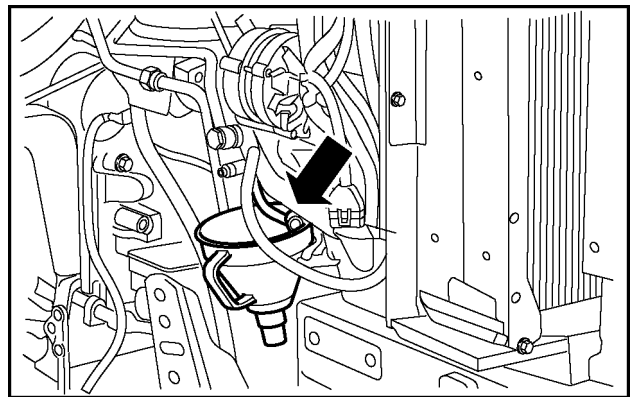

WLAPL4S10C116A 15

17. Take out the plug (1) and drain the oil from the gear-box-transmission casing.

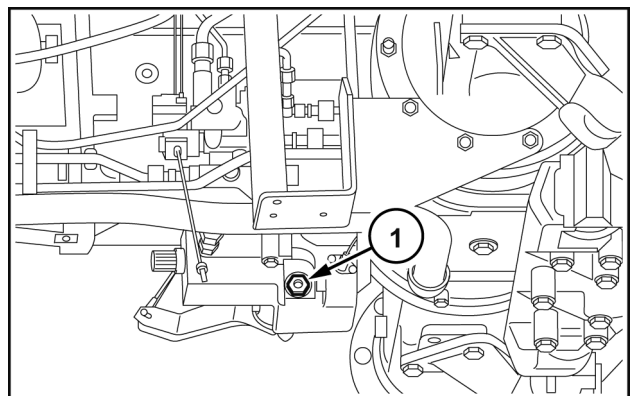

WLAPL4S10C117A 16

<https://www.ebooklibonline.com>

Hello dear friend!

Thank you very much for reading.

Enter the link into your browser.

The full manual is available for immediate download.

<https://www.ebooklibonline.com>