

SERVICE MANUAL

L234

Tier 4B (final)

200 Series Skid Steer Loader

PIN NGM418237 and above

C238

Tier 4B (final)

200 Series Compact Track Loader

PIN NGM418237 and above

Part number 47916233

1st edition English
October 2016





SERVICE MANUAL

C238 TIER 4B (FINAL) [NGM418237 -]
L234 TIER 4B (FINAL) [NGM418237 -]

Link Product / Engine

Product	Market Product	Engine
C238 TIER 4B (FINAL) [NGM418237 -]	North America	F5BFL413A*B007
L234 TIER 4B (FINAL) [NGM418237 -]	North America	F5BFL413A*B007

<https://www.ebooklibonline.com>

Hello dear friend!

Thank you very much for reading.

Enter the link into your browser.

The full manual is available for immediate download.

<https://www.ebooklibonline.com>

Contents

INTRODUCTION

Engine	10
[10.001] Engine and crankcase	10.1
[10.216] Fuel tanks	10.2
[10.206] Fuel filters	10.3
[10.500] Selective Catalytic Reduction (SCR) exhaust treatment.....	10.4
[10.400] Engine cooling system	10.5
[10.414] Fan and drive	10.6
[10.304] Engine lubrication system.....	10.7
Power coupling	19
[19.121] Pump-drive assembly	19.1
Front axle system	25
[25.450] Chain drive system.....	25.1
Rear axle system	27
[27.650] Chain drive system.....	27.1
Hydrostatic drive	29
[29.200] Mechanical control	29.1
[29.218] Pump and motor components.....	29.2
[29.202] Hydrostatic transmission	29.3
Brakes and controls	33
[33.110] Parking brake or parking lock	33.1
Hydraulic systems	35
[35.000] Hydraulic systems.....	35.1
[35.300] Reservoir, cooler, and filters.....	35.2
[35.104] Fixed displacement pump.....	35.3
[35.359] Main control valve	35.4

[35.525] Auxiliary hydraulic valves and lines	35.5
[35.600] High flow hydraulics	35.6
[35.724] Front loader hydraulic system control	35.7
[35.701] Front loader arm hydraulic system	35.8
[35.734] Tool quick coupler hydraulic system	35.9
Frames and ballasting	39
[39.140] Ballasts and supports	39.1
Wheels	44
[44.511] Front wheels.....	44.1
[44.520] Rear wheels.....	44.2
Tracks and track suspension	48
[48.130] Track frame and driving wheels	48.1
[48.100] Tracks	48.2
[48.134] Track tension units	48.3
[48.138] Track rollers	48.4
Cab climate control	50
[50.100] Heating.....	50.1
[50.200] Air conditioning.....	50.2
Electrical systems	55
[55.000] Electrical system	55.1
[55.100] Harnesses and connectors.....	55.2
[55.201] Engine starting system	55.3
[55.302] Battery.....	55.4
[55.011] Fuel tank system	55.5
[55.988] Selective Catalytic Reduction (SCR) electrical system	55.6
[55.012] Engine cooling system	55.7
[55.640] Electronic modules	55.8
[55.019] Hydrostatic drive control system	55.9

[55.512] Cab controls	55.10
[55.036] Hydraulic system control	55.11
[55.050] Heating, Ventilation, and Air-Conditioning (HVAC) control system.....	55.12
[55.518] Wiper and washer system.....	55.13
[55.408] Warning indicators, alarms, and instruments	55.14
[55.991] Telematics	55.15
[55.DTC] FAULT CODES.....	55.16
Front loader and bucket.....	82
[82.100] Arm.....	82.1
[82.300] Bucket.....	82.2
Platform, cab, bodywork, and decals	90
[90.120] Mechanically-adjusted operator seat.....	90.1
[90.124] Pneumatically-adjusted operator seat.....	90.2
[90.150] Cab.....	90.3
[90.154] Cab doors and hatches	90.4



INTRODUCTION

Foreword - Important notice regarding equipment servicing

C238	NA
L234	NA

All repair and maintenance work listed in this manual must be carried out only by qualified dealership personnel, strictly complying with the instructions given, and using, whenever possible, the special tools.

Anyone who performs repair and maintenance operations without complying with the procedures provided herein shall be responsible for any subsequent damages.

The manufacturer and all the organizations of its distribution chain, including - without limitation - national, regional, or local dealers, reject any responsibility for damages caused by parts and/or components not approved by the manufacturer, including those used for the servicing or repair of the product manufactured or marketed by the manufacturer. In any case, no warranty is given or attributed on the product manufactured or marketed by the manufacturer in case of damages caused by parts and/or components not approved by the manufacturer.

The manufacturer reserves the right to make improvements in design and changes in specifications at any time without notice and without incurring any obligation to install them on units previously sold. Specifications, descriptions, and illustrative material herein are as accurate as known at time of publication but are subject to change without notice.

In case of questions, refer to your NEW HOLLAND CONSTRUCTION Sales and Service Networks.

Safety rules

C238	NA
L234 TIER 4B (FINAL) [NGM418237 -]	NA

Personal safety





This is the safety alert symbol. It is used to alert you to potential personal injury hazards. Obey all safety messages that follow this symbol to avoid possible death or injury.

Throughout this manual you will find the signal words DANGER, WARNING, and CAUTION followed by special instructions. These precautions are intended for the personal safety of you and those working with you.

Read and understand all the safety messages in this manual before you operate or service the machine.

 DANGER indicates a hazardous situation that, if not avoided, will result in death or serious injury.

 WARNING indicates a hazardous situation that, if not avoided, could result in death or serious injury.

 CAUTION indicates a hazardous situation that, if not avoided, could result in minor or moderate injury.

FAILURE TO FOLLOW DANGER, WARNING, AND CAUTION MESSAGES COULD RESULT IN DEATH OR SERIOUS INJURY.

Machine safety

NOTICE: Notice indicates a situation that, if not avoided, could result in machine or property damage.

Throughout this manual you will find the signal word Notice followed by special instructions to prevent machine or property damage. The word Notice is used to address practices not related to personal safety.

Information

NOTE: Note indicates additional information that clarifies steps, procedures, or other information in this manual.

Throughout this manual you will find the word Note followed by additional information about a step, procedure, or other information in the manual. The word Note is not intended to address personal safety or property damage.

Safety rules - Personal safety

C238	NA
L234	NA

Carefully study these precautions, and those included in the external attachment operators manual, and insist that they be followed by those working with and for you.

1. Thoroughly read and understand this manual and the attachment Operator's Manual before operating this or any other equipment.
2. Be sure all people and pets are clear of the machine before starting. Sound the horn, if equipped, three times before starting engine.
3. Only the operator should be on the machine when in operation. Never allow anyone to climb on to the machine while it is in motion. If the machine is equipped with an Instructors Seat, this must only be used for training purposes. Passengers must not be allowed to use the Instructors Seat.
4. Keep all shields in place. Never work around the machine or any of the attachments while wearing loose clothing that might catch on moving parts.
5. Observe the following precautions whenever lubricating the machine or making adjustments.
 - Disengage all clutching levers or switches.
 - Lower the attachment, if equipped, to the ground or raise the attachment completely and engage the cylinder safety locks. Completing these actions will prevent the attachment from lowering unexpectedly.
 - Engage the parking brake.
 - Shut off the engine and remove the key.
 - Wait for all machine movement to stop before leaving the operators platform.
6. Always keep the machine in gear while travelling downhill.
7. The machine should always be equipped with sufficient front or rear axle weight for safe operation.
8. Under some field conditions, more weight may be required at the front or rear axle for adequate stability. This is especially important when operating in hilly conditions or/when using heavy attachments.
9. Always lower the attachment, shut off the engine, set the parking brake, engage the transmission gears, remove the key and wait for all machine movement to stop before leaving the operators platform.
10. If the attachment or machine should become obstructed or plugged; set the parking brake, shut off the engine and remove the key, engage the transmission gears, wait for all machine or attachment motion to come to a stop, before leaving the operators platform to removing the obstruction or plug.
11. Never disconnect or make any adjustments to the hydraulic system unless the machine and/or the attachment is lowered to the ground or the safety lock(s) is in the engaged position.
12. Use of the flashing lights is highly recommended when operating on a public road.
13. When transporting on a road or highway, use accessory lights and devices for adequate warning to the operators of other vehicles. In this regard, check local government regulations. Various safety lights and devices are available from your NEW HOLLAND CONSTRUCTION dealer.
14. Practice safety 365 days a year.
15. Keep all your equipment in safe operating condition.
16. Keep all guards and safety devices in place.
17. Always set the parking brake, shut off the engine and remove the key, engage the transmission gears, wait for all machine or attachment motion to come to a stop, before leaving the operators platform to service the machine and attachment.
18. Remember: A careful operator is the best insurance against an accident.
19. Extreme care should be taken in keeping hands and clothing away from moving parts.



SERVICE MANUAL

Engine

C238 TIER 4B (FINAL) [NGM418237 -]
L234 TIER 4B (FINAL) [NGM418237 -]

Engine - Drain fluid

C238 TIER 4B (FINAL) [NGM418237 -]	NA
L234	NA

1. Remove the access cover (2) by removing the mounting bolts (1).

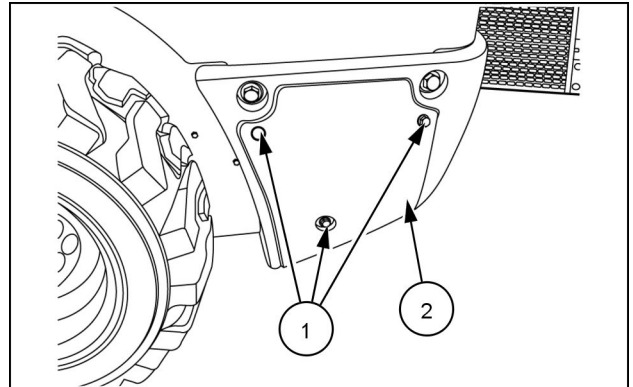

931001637 1

2. Remove the drain plug (1).
3. When the oil has drained from the engine, install the drain plug (1). Torque the drain plug (1) to **68 - 82 N·m (50 - 60 lb ft)**.

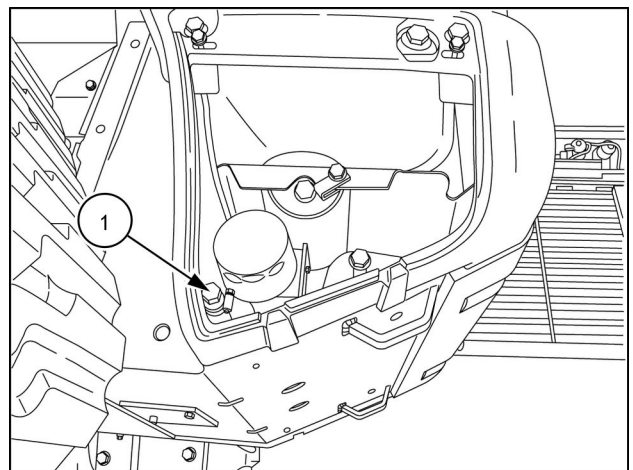

RAIL14SSL0709AA 2

4. Install the access cover (1).

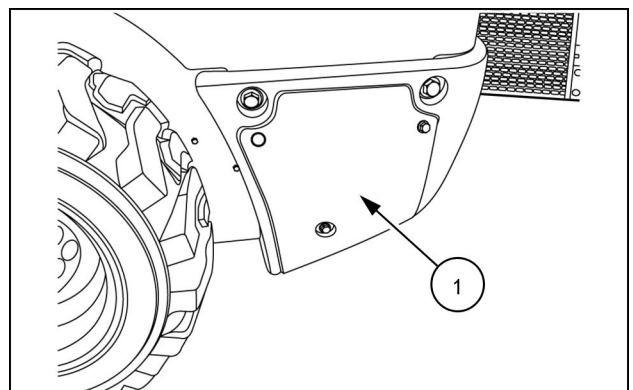

931001637 3

Engine - Remove

⚠ WARNING

Avoid injury! Always do the following before lubricating, maintaining, or servicing the machine.

1. Disengage all drives.
2. Engage parking brake.
3. Lower all attachments to the ground, or raise and engage all safety locks.
4. Shut off engine.
5. Remove key from key switch.
6. Switch off battery key, if installed.
7. Wait for all machine movement to stop.

Failure to comply could result in death or serious injury.

W0047A

⚠ WARNING

Fire hazard!

When handling diesel fuel, observe the following precautions:

1. Do not smoke.
2. Never fill the tank when the engine is running.
3. Wipe up spilled fuel immediately.

Failure to comply could result in death or serious injury.

W0099A

⚠ WARNING

Escaping fluid!

Hydraulic fluid or diesel fuel leaking under pressure can penetrate the skin and cause infection or other injury. To prevent personal injury: Relieve all pressure before disconnecting fluid lines or performing work on the hydraulic system. Before applying pressure, make sure all connections are tight and all components are in good condition. Never use your hand to check for suspected leaks under pressure. Use a piece of cardboard or wood for this purpose. If injured by leaking fluid, see your doctor immediately.

Failure to comply could result in death or serious injury.

W0178A

⚠ WARNING

Heavy objects!

Lift and handle all heavy components using lifting equipment with adequate capacity. Always support units or parts with suitable slings or hooks. Make sure the work area is clear of all bystanders.

Failure to comply could result in death or serious injury.

W0398A

Prior operation:

Tilt the ROPS.

Prior operation:

Disconnect the battery.

Prior operation:

Drain the coolant.

Prior operation:

Drain the engine oil.

Prior operation:

Evacuate the A/C system (if equipped).

1. Remove the access plate **(1)** for the engine oil pan from the rear of the chassis.

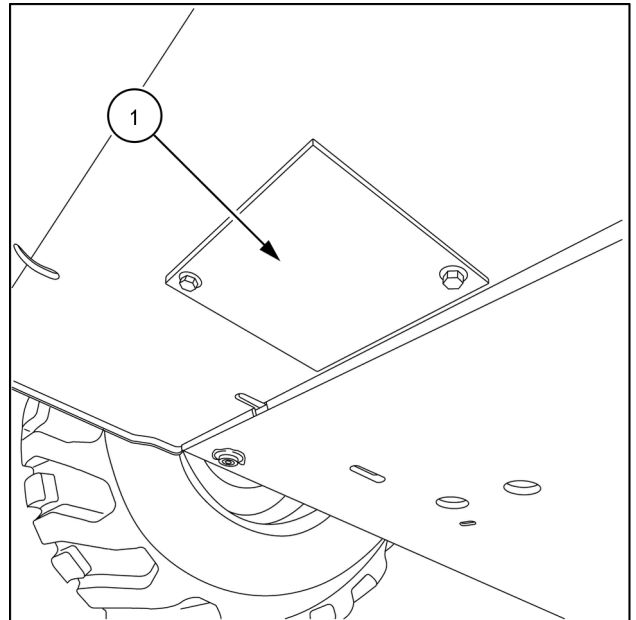

RAPH12SSL0233AA 1

2. Disconnect the hose **(1)** for the oil drain plug from the engine oil pan.

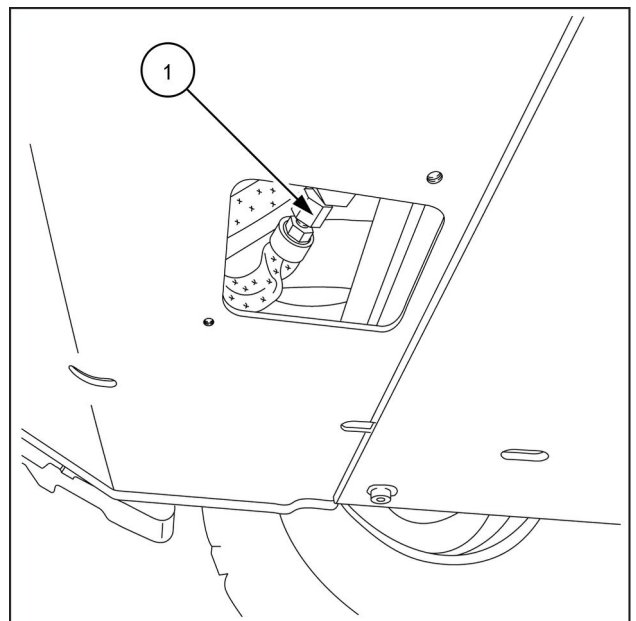

RAPH12SSL0232AA 2

3. Lift the tilting hood.
4. Disconnect the restriction sensor **(1)** for the air filter from the air cleaner assembly.
5. Detach the air cleaner assembly **(2)** from the rear deck.

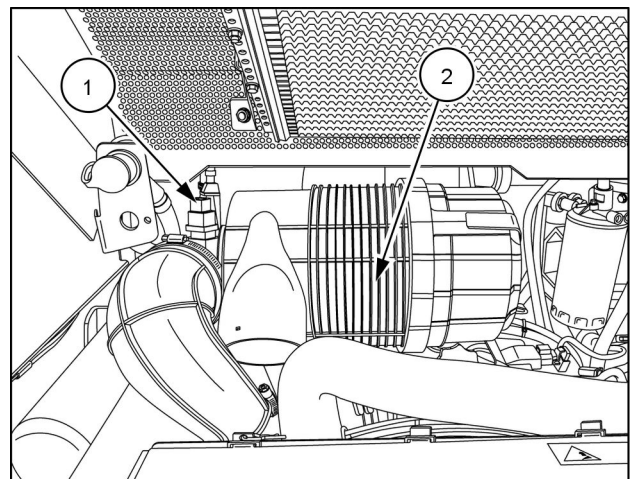

RAIL14SSL0803BA 3

6. If your machine is equipped with A/C, disconnect the lines **(1)** from the A/C condenser.
7. Disconnect the condenser fan **(2)**.

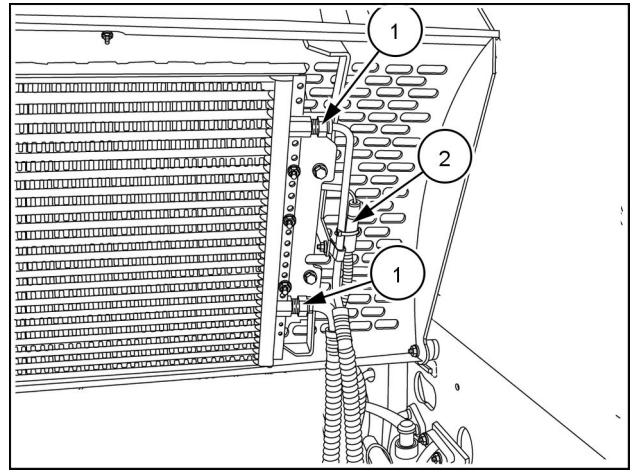

RAPH12SSL0075AA 4

8. Detach the hood strut **(2)** from the tilting hood **(1)**.
9. Remove the tilting hood **(1)** from the rear deck.

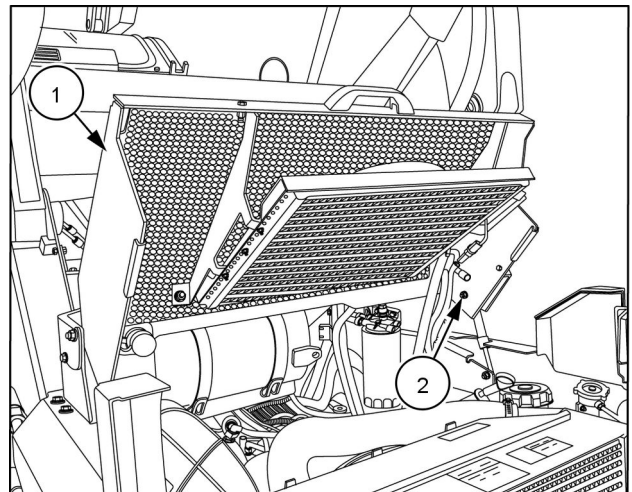

RAIL14SSL0802BA 5

10. Remove the left-hand panel **(1)** from the chassis.
11. Repeat step 10 on the right-hand panel.

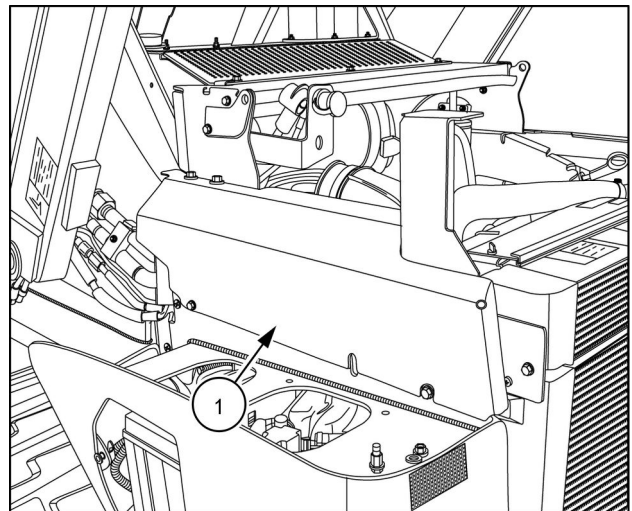

RAIL14SSL0801BA 6

12. Remove the rear deck (1) from the chassis.

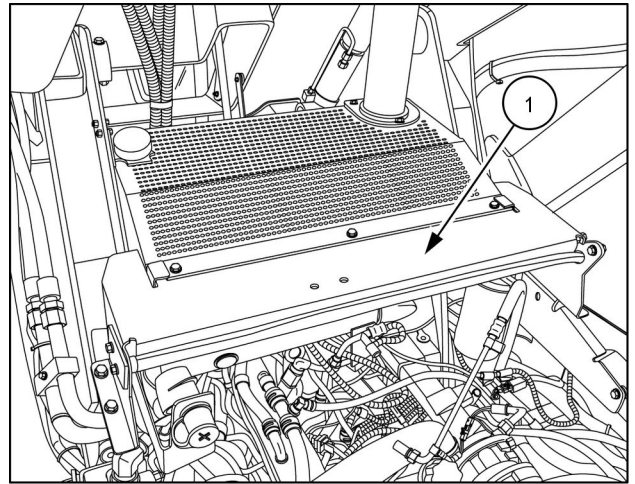

RAIL14SSL0800BA 7

13. Unbolt the retainer, and remove the overflow container.

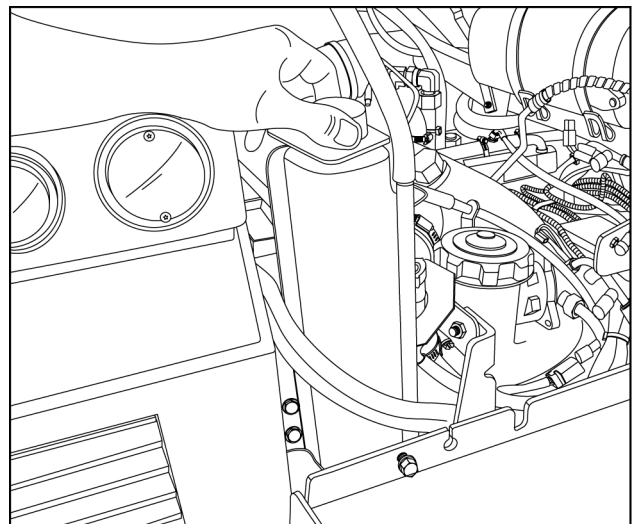

RAIL14SSL0799BA 8

14. Detach the mount (1) for the oil dipstick tube from the shroud.
15. Remove the hose (3) from the filler neck (2).
16. Remove the filler neck (2).

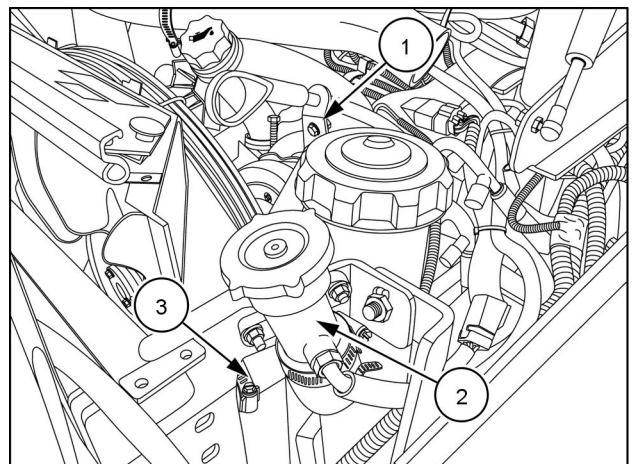

RAIL14SSL0796BA 9



Suggest:

If the above button click is invalid.

Please download this document

first, and then click the above link

to download the complete manual.

Thank you so much for reading

17. Remove the air cooler (1) from the shroud.

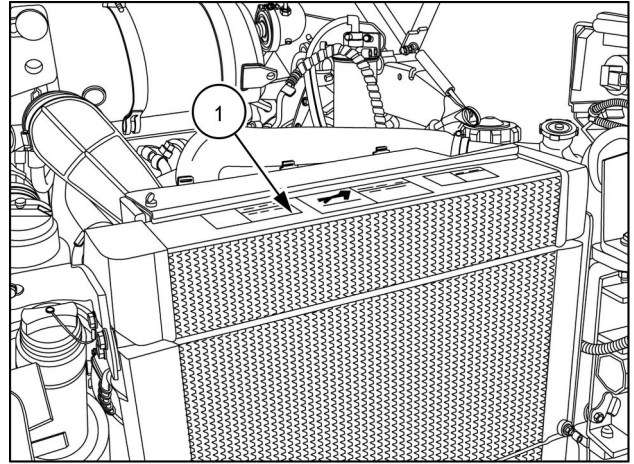

RAIL14SSL0798BA 10

18. Detach the radiator hoses (1) from the radiator (2).
19. Remove the radiator (2) from the shroud.

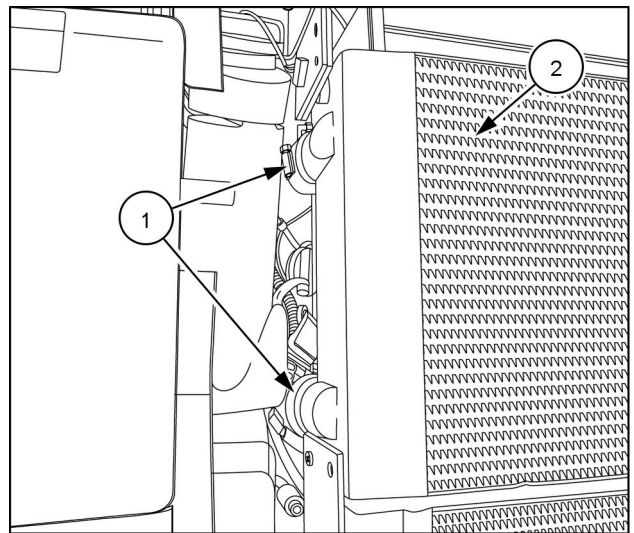

RAIL14SSL0797BA 11

20. Remove the fan (1).

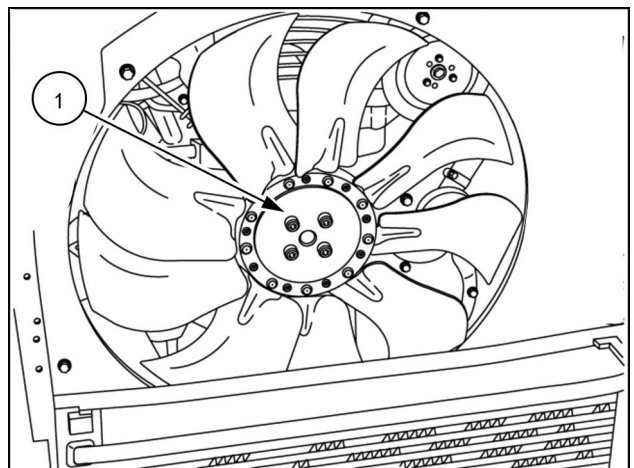

RAPH12SSL0062AA 12

<https://www.ebooklibonline.com>

Hello dear friend!

Thank you very much for reading.

Enter the link into your browser.

The full manual is available for immediate download.

<https://www.ebooklibonline.com>