

SERVICE MANUAL

T4.75V / T4.85V / T4.95V / T4.105V

Tier 3

Tractor

*T4.75V with cab PIN ZDJE10095 and above; T4.75V without cab PIN ZDJE11310 and above;
T4.85V with cab PIN ZDJE11669 and above; T4.85V without cab PIN ZDJE10317 and above;
T4.95V with cab PIN ZDJE11682 and above; T4.95V without cab PIN ZDJE11554 and above;
T4.105V with cab PIN ZDJE17896 and above; T4.105V without cab PIN ZDJE13827 and above*

Part number 47888375

1st edition English
July 2016





SERVICE MANUAL

T4.105V With cab [ZDJE17896 -], T4.105V Without cab [ZDJE13827 -], T4.75V With cab [ZDJE10095 -], T4.75V Without cab [ZDJE11310 -], T4.85V With cab [ZDJE11669 -], T4.85V Without cab [ZDJE10317 -], T4.95V With cab [ZDJE11682 -], T4.95V Without cab [ZDJE11554 -]

Link Product / Engine

Product	Market Product	Engine
T4.105V With cab [ZDJE17896 -]	North America	F4CE9484
T4.105V Without cab [ZDJE13827 -]	North America	F4CE9484
T4.75V With cab [ZDJE10095 -]	North America	F5AE9484B
T4.75V Without cab [ZDJE11310 -]	North America	F5AE9484B
T4.85V With cab [ZDJE11669 -]	North America	F5AE9484G
T4.85V Without cab [ZDJE10317 -]	North America	F5AE9484G
T4.95V With cab [ZDJE11682 -]	North America	F4CE9484
T4.95V Without cab [ZDJE11554 -]	North America	F4CE9484

<https://www.ebooklibonline.com>

Hello dear friend!

Thank you very much for reading.

Enter the link into your browser.

The full manual is available for immediate download.

<https://www.ebooklibonline.com>

Contents

INTRODUCTION

Engine.....	10
[10.001] Engine and crankcase	10.1
Clutch	18
[18.100] Clutch mechanical release control	18.1
[18.104] Clutch hydraulic release control.....	18.2
[18.110] Clutch and components	18.3
Transmission.....	21
[21.114] Mechanical transmission	21.1
[21.130] Mechanical transmission external controls.....	21.2
[21.140] Mechanical transmission internal components.....	21.3
[21.112] Power shuttle transmission.....	21.4
[21.134] Power shuttle transmission external controls	21.5
[21.154] Power shuttle transmission internal components	21.6
[21.145] Gearbox internal components.....	21.7
[21.160] Creeper	21.8
[21.162] Reverser	21.9
[21.168] Hi-Lo unit.....	21.10
[21.182] Differential.....	21.11
Four-Wheel Drive (4WD) system	23
[23.304] Four-Wheel Drive (4WD) gearbox	23.1
[23.314] Drive shaft.....	23.2
Front axle system	25
[25.100] Powered front axle	25.1
[25.102] Front bevel gear set and differential	25.2
[25.108] Final drive hub, steering knuckles, and shafts	25.3

[25.122] Axle suspension control	25.4
[25.310] Final drives	25.5
[25.400] Non-powered front axle	25.6
Rear axle system.....	27
[27.100] Powered rear axle.....	27.1
[27.106] Rear bevel gear set and differential	27.2
[27.120] Planetary and final drives	27.3
[27.126] Spur gear and final drives.....	27.4
Power Take-Off (PTO).....	31
[31.101] Rear mechanical control	31.1
Brakes and controls	33
[33.202] Hydraulic service brakes	33.1
[33.110] Parking brake or parking lock	33.2
[33.220] Trailer brake hydraulic control.....	33.3
Hydraulic systems.....	35
[35.000] Hydraulic systems.....	35.1
[35.300] Reservoir, cooler, and filters.....	35.2
[35.104] Fixed displacement pump	35.3
[35.204] Remote control valves	35.4
[35.600] High flow hydraulics	35.5
[35.100] Main lift system.....	35.6
[35.114] Three-point hitch control valve	35.7
[35.116] Three-point hitch cylinder	35.8
Hitches, drawbars, and implement couplings.....	37
[37.110] Rear three-point hitch	37.1
[37.108] Rear three-point hitch external controls	37.2
[37.162] Front hitch	37.3
Steering.....	41

[41.101] Steering control	41.1
[41.200] Hydraulic control components.....	41.2
Wheels	44
[44.511] Front wheels.....	44.1
Cab climate control	50
[50.100] Heating	50.1
[50.104] Ventilation	50.2
[50.200] Air conditioning.....	50.3
Electrical systems	55
[55.000] Electrical system	55.1
[55.100] Harnesses and connectors.....	55.2
[55.201] Engine starting system	55.3
[55.301] Alternator.....	55.4
[55.302] Battery.....	55.5
[55.202] Cold start aid	55.6
[55.640] Electronic modules	55.7
[55.051] Cab Heating, Ventilation, and Air-Conditioning (HVAC) controls.....	55.8
[55.050] Heating, Ventilation, and Air-Conditioning (HVAC) control system.....	55.9
[55.047] Steering control system	55.10
[55.523] Cab hitch controls	55.11
[55.130] Rear three-point hitch electronic control system	55.12
[55.404] External lighting	55.13
[55.514] Cab lighting	55.14
[55.511] Light harnesses	55.15
[55.408] Warning indicators, alarms, and instruments	55.16
[55.DTC] FAULT CODES.....	55.17
Platform, cab, bodywork, and decals	90
[90.110] Operator platform less cab	90.1

[90.114] Operator protections 90.2

[90.150] Cab 90.3

[90.151] Cab interior 90.4

[90.154] Cab doors and hatches 90.5

[90.100] Engine hood and panels 90.6

[90.102] Engine shields, hood latches, and trims 90.7

[90.160] Cab interior trim and panels 90.8



INTRODUCTION

Safety rules SAFETY REGULATIONS

TO PREVENT ACCIDENTS

Most accidents or injuries that occur in workshops are the result of non-observance of simple and fundamental safety regulations.

For this reason, IN MOST CASES THESE ACCIDENTS CAN BE AVOIDED: by foreseeing possible causes and consequently acting with the necessary caution and care.

Accidents may occur with all types of vehicle, regardless of how well it was designed and built.

A careful and judicious service technician is the best guarantee against accidents.

Precise observance of the most basic safety rule is normally sufficient to avoid many serious accidents.

DANGER: Never carry out any cleaning, lubrication or maintenance operations when the engine is running.

GENERAL

- Carefully follow specified repair and maintenance procedures.
- Do not wear rings, wristwatches, jewellery, unbuttoned or loose articles of clothing such as: ties, torn clothing, scarves, open jackets or shirts with open zips that may remain entangled in moving parts.
It is advised to wear approved safety clothing, e.g: non-slip footwear, gloves, safety goggles, helmets, etc.
- Do not carry out repair operations with someone sitting in the driver's seat, unless the person is a trained technician who is assisting with the operation in question.
- Operate the vehicle and use the implements exclusively from the driver's seat.
- Do not carry out operations on the vehicle with the engine running, unless specifically indicated.
- Stop the engine and ensure that all pressure is relieved from hydraulic circuits before removing caps, covers, valves, etc.
- All repair and maintenance operations must be carried out using extreme care and attention.
- Service steps and platforms used in a workshop or in the field should be built in compliance with the safety rules in force.
- Disconnect the batteries and label all controls to indicate that the vehicle is being serviced. Block the machine and all equipment which should be raised.
- Do not check or fill fuel tanks, accumulator batteries, nor use starting liquid when smoking or near naked flames, as these fluids are inflammable.
- Brakes are inoperative if manually released for repair or maintenance purposes.
In such cases, the machine should be kept constantly under control using blocks or similar devices.
- The fuel nozzle should always be in contact with the filling aperture. Maintain this position until filling operations are completed in order to avoid possible sparks caused by the accumulation of static electricity.
- Only use specified towing points for towing the tractor, connect parts carefully. Make sure that all pins and/or locks are secured in position before applying traction.
Never remain near the towing bars, cables or chains that are operating under load
- Transport vehicles that cannot be driven using a trailer or a low-loading platform trolley, if available.
- When loading or unloading the vehicle from the trailer (or other means of transport), select a flat area capable of sustaining the trailer or truck wheels, firmly secure the tractor to the truck or trailer and lock the wheels in the position.
- Electric heaters, battery-chargers and similar equipment must only be powered by auxiliary power supplies with efficient ground insulation to avoid electrical shock hazards.
- Always use suitable hoisting or lifting devices when raising or moving heavy parts.
- Take extra care if bystanders are present.
- Never pour gasoline or diesel oil into open, wide and low containers.
- Never use gasoline, diesel oil or other inflammable liquids as cleaning agents. Use non-flammable non-toxic proprietary solvents.
- Wear safety goggles with side guards when cleaning parts with compressed air.
- Limit the air pressure to a maximum of **2.1 bar (30.5 psi)**, according to local regulations.

INTRODUCTION

- Do not run the engine in confined spaces without suitable ventilation.
- Do not smoke, use naked flames, or cause sparks in the area when fuel filling or handling highly inflammable liquids.
- Never use naked flames for lighting when working on the machine or checking for leaks.
- All movements must be carried out carefully when working under, on or near the vehicle and wear protective equipment: helmets, goggles and special footwear.
- When carrying out checks with the engine running, request the assistance of an operator in the driver's seat. The operator must maintain visual contact with the service technician at all times.
- If operating outside the workshop, position the vehicle on a flat surface and lock in position. If working on a slope, lock the vehicle in position and move to a flat area as soon as is safely possible.
- Damaged or bent chains or cables are unreliable. Do not use them for lifting or towing. Always use suitable protective gloves when handling chains or cables.
- Chains should always be safely secured. Ensure that fastening device is strong enough to hold the load foreseen. No persons should stop near the fastening point, trailing chains or cables.
- Maintenance and repair operations must be carried out in a CLEAN and DRY area, eliminate any water or oil spillage immediately.
- Do not create piles of oil or grease--soaked rags as they represent a serious fire hazard; store them in a closed metal container.
Before starting the vehicle or implements, make sure that the driver's seat is locked in position and always check that the area is free of persons or obstacles.
- Empty pockets of all objects that may fall unobserved into the vehicle parts when disassembled.
- In the presence of protruding metal parts, use protective goggles or goggles with side guards, helmets, special footwear and gloves.
- Handle all parts carefully, do not put your hands or fingers between moving parts, wear suitable safety clothing -- safety goggles, gloves and shoes.

WELDING OPERATIONS

- When welding, use protective safety devices: tinted safety goggles, helmets, special overalls, gloves and footwear. All persons present in the area where welding is taking place must wear tinted goggles.
NEVER LOOK AT THE WELDING ARC IF YOUR EYES ARE NOT SUITABLY PROTECTED.
- Where possible, remove the part or tool that requires arc welding from the tractor.
- Disconnect both battery leads. Isolate the cable ends to avoid contact with each other and the tractor.
- Position the welder ground clamp as near as possible to the area where welding is taking place.
- Remove the electronic control units located on the tractor if welding is to be carried out near these control units.
- Never allow welding cables to lay on, near or across any electrical wiring or electronic component while welding is in progress.
- Metal cables tend to fray with repeated use. Always use suitable protective devices (gloves, goggles, etc.) when handling cables.

START UP

- Never start the engine in confined spaces that are not equipped with adequate ventilation for exhaust gas extraction.
- Never place the head, body, limbs, feet, hands or fingers near fans or rotating belts.

ENGINE

- Always loosen the radiator cap slowly before removing it to allow any remaining pressure in the system to be discharged. Coolant should be topped up only when the engine is stopped or idle if hot.
- Never fill up with fuel when the engine is running, especially if hot, in order to prevent the outbreak of fire as a result of fuel spillage
- Never check or adjust fan belt tension when the engine is running.
Never adjust the fuel injection pump when the vehicle is moving.

- Never lubricate the vehicle when the engine is running.

ELECTRICAL SYSTEMS

- If it is necessary to use auxiliary batteries, remember that both ends of the cables must be connected as follows: (+) with (+) and (-) with (-).
- Avoid short-circuiting the terminals. **GAS RELEASED FROM BATTERIES IS HIGHLY INFLAMMABLE.**
- During charging, leave the battery compartment uncovered to improve ventilation.
- Never check the battery charge using "jumpers" (metal objects placed on the terminals).
- Avoid sparks or flames near the battery zone to prevent explosion hazards.
- Before servicing operations, check for fuel or current leaks. Eliminate any eventual leaks before starting work.
- Never charge batteries in confined spaces. Make sure that there is adequate ventilation in order to prevent accidental explosion hazards as a result of the accumulation of gases released during charging operations.
- Always disconnect the battery before performing any kind of servicing on the electrical system.

HYDRAULIC SYSTEMS

- Some fluid slowly coming out from a very small port can be almost invisible and be strong enough to penetrate the skin. Check for leaks using a piece of cardboard, **NEVER USE HANDS.**
- If any liquid penetrates skin tissue, call for medical aid immediately
- Serious skin infections may result if medical attention is not given.
- Use the specific tools when checking pressure values on the hydraulic system.

WHEELS AND TYRES

- Check that the tyres are correctly inflated at the pressure specified by the manufacturer. Periodically check possible damages to the rims and tyres.
- Stand away from (at the side of) the tire when checking inflation pressure.
- Only check pressure when the vehicle is unloaded and the tires are cold, to avoid incorrect readings as a result of over--pressure.
- Do not re--use parts of recovered wheels as incorrect welding or brazing may heat the material, causing it to weaken and eventually damage or break the wheel.
- Never cut, nor weld a rim with the inflated tyre assembled.
- When removing the wheels, lock both the front and rear vehicle wheels.
- Always position support stands when raising the vehicle, in order to conform to current safety regulations.
- Deflate the tyre before removing any object caught into the tyre tread.
- Never inflate tires using inflammable gases; this could cause an explosion and put operator safety at risk.

REMOVAL AND RE-FITTING

- Lift and handle all heavy parts using suitable lifting equipment and make sure that all slings and hooks are correctly secured.
- Handle all parts carefully during lifting operations, keep an eye on the personnel working near the load to be lifted. Never insert hands or fingers between parts, always wear approved accident prevention clothing (goggles, gloves and work boots).
- Avoid twisting chains or metal cables and always wear safety gloves when handling cables or chains.



Engine - 10

Engine and crankcase - 001

T4.105V With cab [ZDJE17896 -], T4.105V Without cab [ZDJE13827 -], T4.75V With cab [ZDJE10095 -], T4.75V Without cab [ZDJE11310 -], T4.85V With cab [ZDJE11669 -], T4.85V Without cab [ZDJE10317 -], T4.95V With cab [ZDJE11682 -], T4.95V Without cab [ZDJE11554 -]

Engine - Remove

1. Remove the cab as described in operation "**Cab - Remove (90.150)**".
2. Extract the fixing pin and remove the ballast **(1)** ; unscrew the retaining screws and retrieve the ballast support **(2)** .

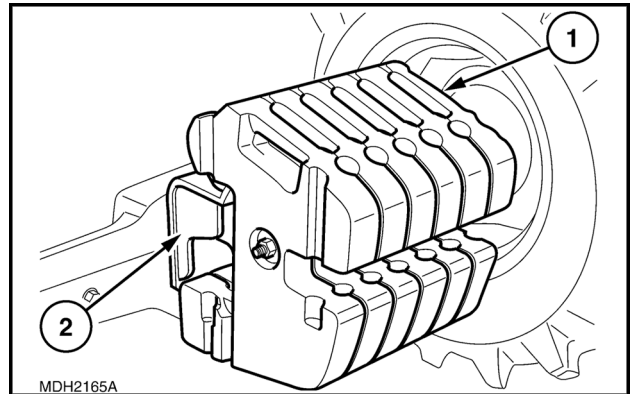

WLSPVNS10C1-10A 1

3. Carry out operation in: **Drive shaft - Disassemble (21.145)**, propeller shafts and guard, only removal.
4. Unscrew the plug and drain the front transmission casing (prescribed quantity: **44 l (11.62 US gal)**).

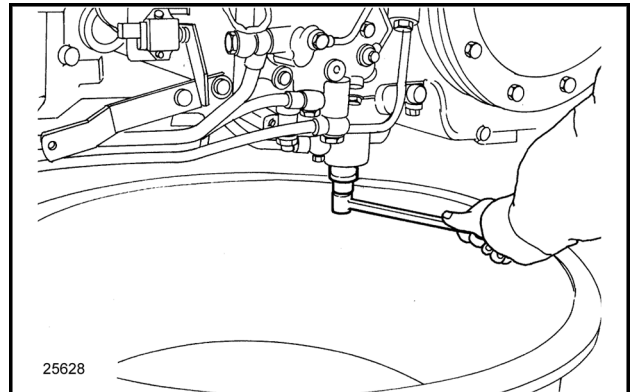

WLSPVNS10C1-11A 2

5. Disconnect the pipes (**(1)** and **(2)**) of the transmission oil cooler and of the front axle differential lock.

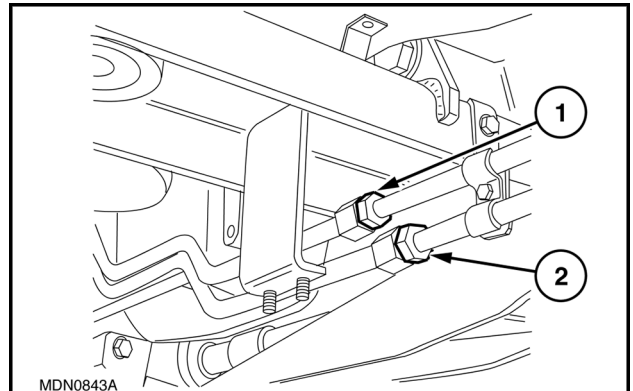

WLSPVNS10C1-12A 3

6. Disconnect: the transmission oil cooler pipes **(1)** and the front axle differential lock pipe **(2)** .

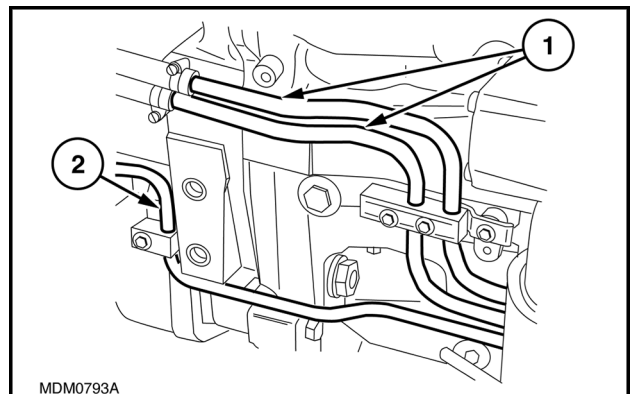

WLSPVNS10C1-13A 4

7. Unscrew: the retaining bolts of the pipe **(1)** delivering oil to the pump and the bolts retaining the pipe **(2)** to the filter support.

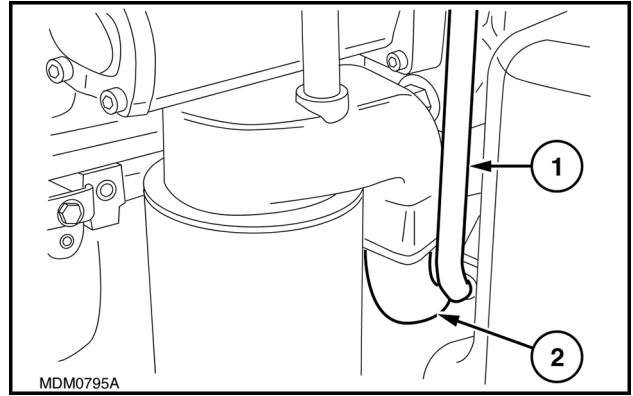

8. Loosen the related clamps and remove the sleeve **(2)** from the pipe **(1)** and remove the transmission oil inlet pipe together with the above-mentioned sleeve.

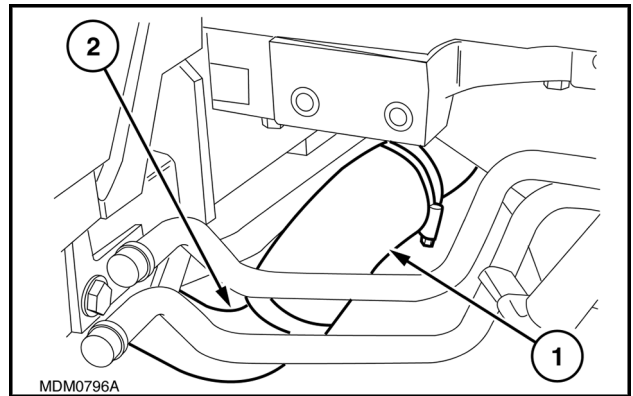

9. Unscrew the fixing clamps and disconnect the pipes **(1)** and **(2)** from the cooler, the sleeve **(4)** between the air filter and the turbocharger and the oil vapour recirculation pipe **(3)**.

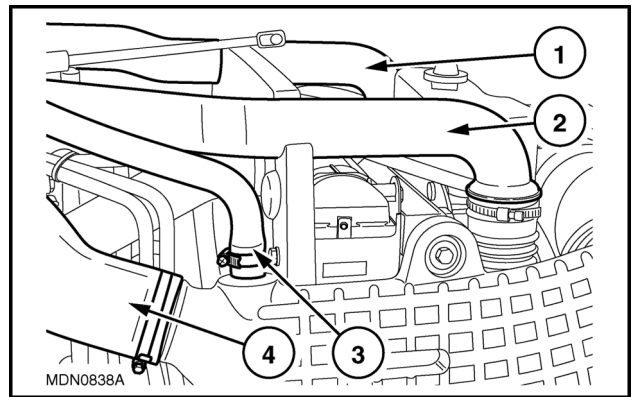

10. Disconnect the secondary tank fuel level connection **(1)** and the clogged air filter pressure switch connection.

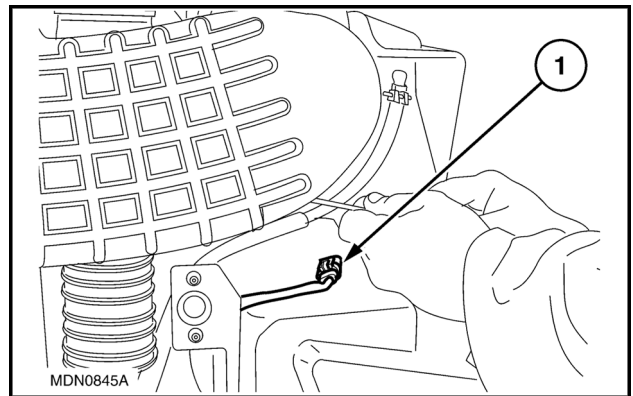

11. Disconnect the steering hydraulic cylinder control pipes (1) .

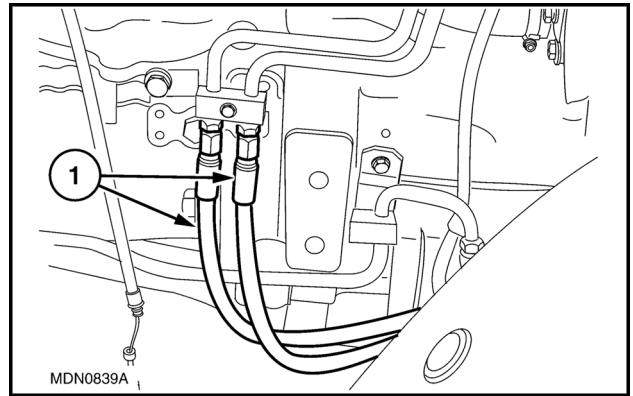

WLSPVNS10C1-18A 9

12. Unscrew the fixing clamps and detach the upper (1) and lower (2) sleeves from the engine radiator.

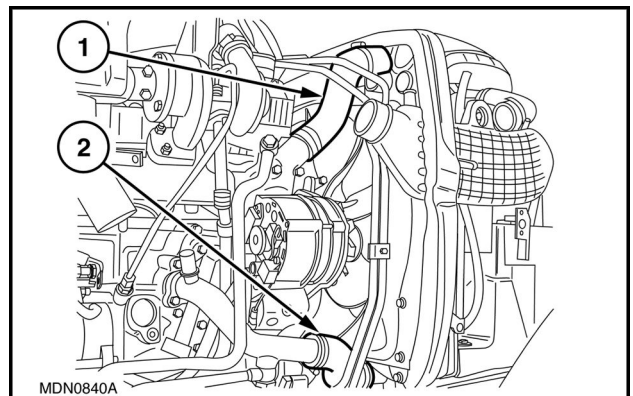

WLSPVNS10C1-19A 10

13. Unhook the catch and extract the transmission oil radiator (1) .

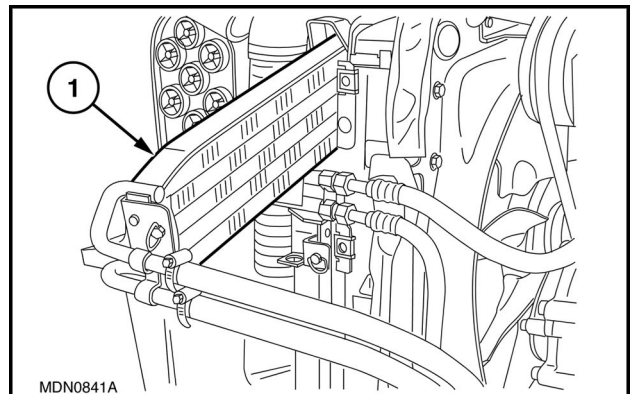

WLSPVNS10C1-20A 11

14. Disconnect the pipes (1) of the air-conditioning system from the related condenser.

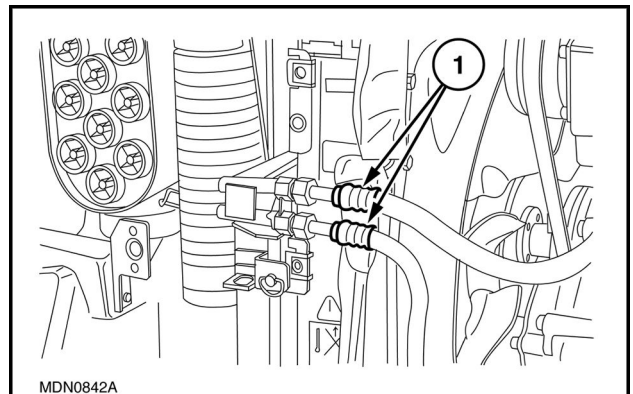

WLSPVNS10C1-21A 12

15. Unscrew the fixing screws, loosen the related clamp and detach the pipe (1) joining the tanks: main to secondary.

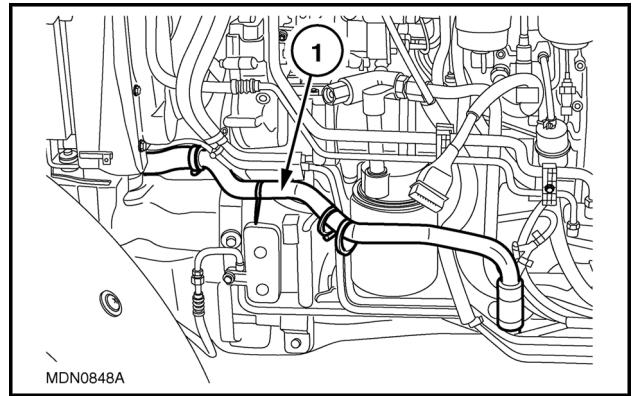

WLSPVNS10C1-22A 13

16. Unscrew the fixing screw and detach the bracket (1) locking the engine radiator.

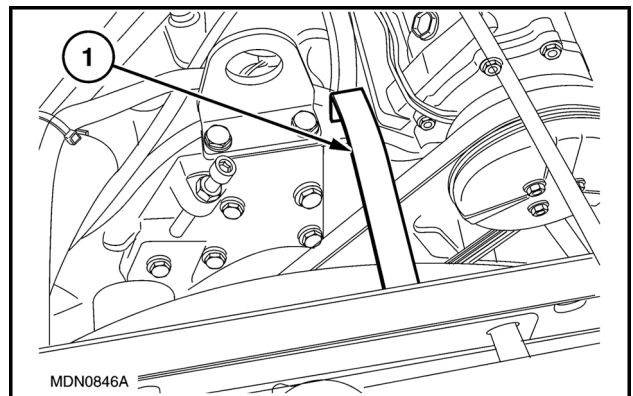

WLSPVNS10C1-23A 14

17. Position a fixed stand under the transmission-clutch casing.
18. Connect the engine to the hoist using a chain and make it take up the strain.
19. Unscrew the bolts (1) securing the engine to the transmission-clutch casing and detach the engine assembly and front axle.

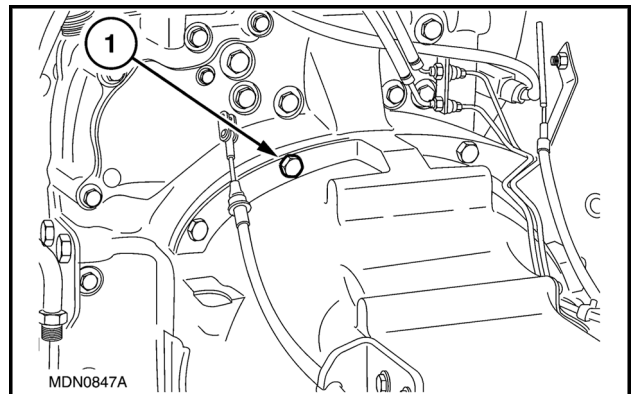

WLSPVNS10C1-24A 15

20. Set up two fixed stands: one under the axle support at the rear and the other under the front side.
21. Unscrew the bolts (1) on both sides and separate the engine from the axle-support assembly with the radiators.
22. Rest the engine on an adequate support.

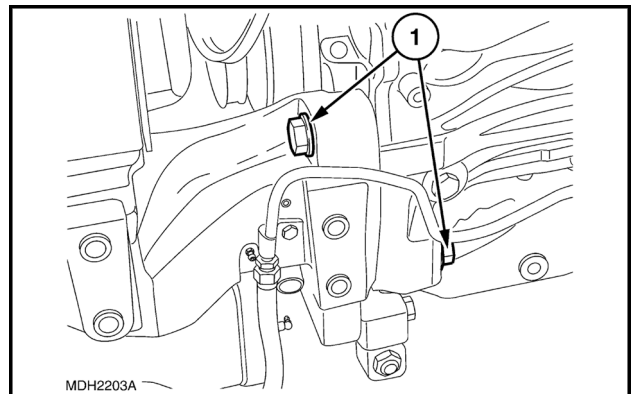

WLSPVNS10C1-26A 16



Suggest:

If the above button click is invalid.

Please download this document

first, and then click the above link

to download the complete manual.

Thank you so much for reading

Engine - Install

1. Respect the tightening torques.
2. Connect the engine, with chains, to the hoist.
3. Refit the engine to the front axle-support assembly with the radiator and cooler.
4. Before refitting the engine to the clutch box carefully clean the mating surfaces and apply sealing compound (**2 mm (0.08 in)** diameter), according to the diagram shown in **Transmission housing - Reseal (21.114)** .
5. Position the engine on the clutch casing and secure it with the specific bolts.
6. Position and secure the retaining bracket between the radiator and engine.
7. Secure the pipe joining the main tank to the secondary one.
8. Position and secure the guard between the radiator and engine.
9. Connect the air-conditioning system pipes to the condenser.
10. Insert the transmission oil radiator into its seat and secure it.
11. Connect and secure the top and bottom sleeves to the engine radiator.
12. Connect the steering cylinder control piping.
13. Connect the electrical connections of the secondary tank fuel level and clogged air filter.
14. Position and secure the connecting pipes of the cooler, turbocharger, air filter and oil vapour recirculation.
15. Position and connect the transmission oil inlet pipe.
16. Position and secure the pipes of the transmission oil filter support.
17. Connect the transmission oil cooler and front axle differential lock pipes.
18. Carry out operation **Drive shaft - Assemble (21.145)** Propeller shafts and guard, only installation
19. Connect the cooler and front axle differential lock pipes.
20. For models fitted with brakes on the front axle it is necessary to fill the relevant tank (see dedicated section for the prescribed product and quantity) and bleed the braking system.
21. Screw the plug on the rear transmission casing and fill up with oil (see dedicated section for the prescribed product and quantity).
22. Position and secure the ballast support.
23. Position and secure the ballast.
24. Install the cab as described in operation **Cab - Install (90.150)**.

<https://www.ebooklibonline.com>

Hello dear friend!

Thank you very much for reading.

Enter the link into your browser.

The full manual is available for immediate download.

<https://www.ebooklibonline.com>