

SERVICE MANUAL

Boomer™ 3040

Boomer™ 3045

Boomer™ 3050

With Hydrostatic or 12x12 Gear Transmission

Compact Tractor

Part number 84242309

1st edition English
August 2012



Contents

INTRODUCTION

Engine	10
Engine and crankcase.....	10.001
Cylinder heads	10.101
Pan and covers.....	10.102
Crankshaft and flywheel	10.103
Connecting rods and pistons	10.105
Valve drive and gears	10.106
Balancer and damper.....	10.110
Pump drives	10.114
Lift pump and lines	10.210
Fuel tanks	10.216
Fuel injection system	10.218
Intake and exhaust manifolds and muffler.....	10.254
Engine lubrication system	10.304
Engine cooling system	10.400
Fan and drive.....	10.414
Clutch	18
Clutch hydraulic release control	18.104
Clutch and components	18.110
Transmission	21
Mechanical transmission	21.114
Mechanical transmission external controls	21.130
Mechanical transmission internal components	21.140
Front axle system	25
Powered front axle	25.100
Front bevel gear set and differential	25.102

Final drive hub, steering knuckles, and shafts	25.108
Final drives	25.310
Rear axle system	27
Powered rear axle	27.100
Rear bevel gear set and differential	27.106
Planetary and final drives	27.120
Hydrostatic drive	29
Transmission and steering hydrostatic control	29.100
Hydrostatic transmission	29.202
Reservoir, cooler, and lines	29.204
Pump and motor components	29.218
Power Take-Off (PTO)	31
Rear electrohydraulic control	31.104
Two-speed rear Power Take-Off (PTO)	31.114
Central Power Take-Off (PTO)	31.120
Brakes and controls	33
Parking brake / Parking lock	33.110
Mechanical service brakes	33.120
Hydraulic systems	35
Hydraulic systems	35.000
Pump control valves	35.102
Fixed displacement pump	35.104
Three-point hitch control valve	35.114
Remote control valves	35.204
Reservoir, cooler, and filters	35.300
Regulated/Low pressure system	35.322
Safety and main relief valves	35.350
Hitches, drawbars, and implement couplings	37
Rear three-point hitch	37.110

<https://www.ebooklibonline.com>

Hello dear friend!

Thank you very much for reading.

Enter the link into your browser.

The full manual is available for immediate download.

<https://www.ebooklibonline.com>

Steering	41
Hydraulic control components	41.200
Pump	41.206
Cylinders	41.216
Cab climate control	50
Heating	50.100
Ventilation	50.104
Air conditioning	50.200
Electrical systems	55
Electrical system	55.000
Heating, Ventilation, and Air-Conditioning (HVAC) control system	55.050
Cab Heating, Ventilation, and Air-Conditioning (HVAC) controls	55.051
Harnesses and connectors	55.100
Engine starting system	55.201
Cold start aid	55.202
Alternator	55.301
Battery	55.302
Warning indicators, alarms, and instruments	55.408
Wiper/Washer system	55.518
Cab engine controls	55.525
Platform, cab, bodywork, and decals	90
Engine hood and panels	90.100
Engine shields, hood latches, and trims	90.102
Protections - ROPS and FOPS	90.114
Pneumatically-adjusted operator seat	90.124
Cab	90.150
Cab interior	90.151
Cab doors and hatches	90.154



INTRODUCTION

Foreword

This service manual provides the technical information needed to properly service the NEW HOLLAND AGRICULTURE Boomer 3040, 3045, and 3050 model tractors. Use this manual in conjunction with the operator's manual for complete operation, adjustment, and maintenance information

On NEW HOLLAND AGRICULTURE equipment, left and right are determined by standing behind the unit, looking in the direction of travel.

Safety rules

PRECAUTIONARY STATEMENTS

Personal Safety

Throughout this manual and on machine signs, you will find precautionary statements ("DANGER", "WARNING", and "CAUTION") followed by specific instructions. These precautions are intended for the personal safety of you and those working with you. Please take the time to read them.



This word "DANGER" indicates an immediate hazardous situation that, if not avoided, will result in death or serious injury. The color associated with Danger is RED.

M1169



This word "WARNING" indicates a potentially hazardous situation that, if not avoided, could result in death or serious injury. The color associated with Warning is ORANGE.

M1170



This word "CAUTION" indicates a potentially hazardous situation that, if not avoided, may result in minor or moderate injury. It may also be used to alert against unsafe practices. The color associated with Caution is YELLOW.

M1171

FAILURE TO FOLLOW THE "DANGER", "WARNING", AND "CAUTION" INSTRUCTIONS MAY RESULT IN SERIOUS BODILY INJURY OR DEATH.

Machine Safety

The precautionary statement ("IMPORTANT") is followed by specific instructions. This statement is intended for machine safety.

NOTICE: The word "IMPORTANT" is used to inform the reader of something they need to know to prevent minor machine damage if a certain procedure is not followed.

Information

NOTE: Instructions used to identify and present supplementary information.

LEGAL OBLIGATIONS

This machine may be equipped with special guarding or other devices in compliance with local legislation. Some of these require active use by the operator. Therefore, check local legislation on the usage of this machine.

ACCIDENT PREVENTION

Most accidents or injuries that occur in workshops are the result of a non compliance to simple and fundamental safety regulations. For this reason, IN MOST CASES THESE ACCIDENTS CAN BE AVOIDED by foreseeing possible causes and consequently acting with the necessary caution and care.

Accidents may occur with all types of machines, regardless of how well the machine in question was designed and built.

A careful and informed service technician is the best guarantee against accidents.

Decisive awareness of the most basic safety rule is normally sufficient to avoid many serious accident.



Shut down the machine, remove key, be sure all moving parts have stopped and all pressure in the systems is relieved before cleaning, adjusting or lubricating the equipment. Failure to comply will result in death or serious injury.

M871

SAFETY REQUIREMENTS FOR FLUID POWER SYSTEMS AND COMPONENTS - HYDRAULICS (EUROPEAN STANDARD PR EM 982)

Flexible hose assemblies must not be constructed from hoses which have been previously used as part of a hose assembly.

Do not weld hydraulic piping.

When flexible hoses or piping are damaged, replace them immediately.

It is forbidden to modify a hydraulic accumulator by machining, welding or any other means.

Before removing hydraulic accumulators for servicing, the liquid pressure in the accumulators must be reduced to zero.

Pressure check on hydraulic accumulators shall be carried out by method recommended by the accumulator manufacturer.

Care must be taken not to exceed the maximum allowable pressure of the accumulator. After any check or adjustment there must be no leakage of gas.

SAFETY RULES

A careful operator is the best operator. Most accidents can be avoided by observing certain precautions. To help prevent accidents, read and take the following precautions before operating this tractor. Equipment should be operated only by those who are responsible and instructed to do so.

THE TRACTOR

1. Read the Operator's Manual carefully before using the tractor. Lack of operating knowledge can lead to accidents.
2. Use an approved roll bar and seat belt for safe operation. Overturning a tractor without a roll bar can result in death or injury. If your tractor is not equipped with a roll bar and seat belt, see your NEW HOLLAND AGRICULTURE Dealer.
3. Always use the seat belt. The only instance when the seat belt should not be used is if the roll bar has been removed from the tractor or folding ROPS is in down position.
4. If a front end loader is to be installed, always use a FOPS (Falling Object Protective Structure) canopy to avoid injury from falling objects.
5. Use the handholds and step plates when getting on and off the tractor to prevent falls. Keep steps and platform cleared of mud and debris.
6. Do not permit anyone but the operator to ride on the tractor. There is no safe place for extra riders.
7. Keep all safety decals clean of dirt and grime, and replace all missing, illegible, or damaged safety decals. See the list of decals in the Decal section of this manual.

SERVICING THE TRACTOR

1. The cooling system operates under pressure which is controlled by the radiator cap. It is dangerous to remove the cap while the system is hot. Always turn the cap slowly to the first stop and allow pressure to escape before removing the cap entirely.
2. Keep any type of open flame away from the tractor and do not smoke while refueling. Wait for the engine to cool before refueling.
3. Keep the tractor and equipment, particularly brakes and steering, maintained in a reliable and satisfactory condition to ensure your safety and comply with legal requirements.
4. Keep open flame or cold weather starting aids away from the battery to prevent fires or explosions. Use jumper cables according to instructions to prevent sparks which could cause explosion.

INTRODUCTION

5. Stop the engine before performing any service on the tractor.
6. Escaping hydraulic/diesel fluid under pressure can penetrate the skin causing serious injury. If fluid is injected into the skin, obtain medical attention immediately or gangrene may result.
 - DO NOT use your hand to check for leaks.
 - Use a piece of cardboard or paper to search for leaks.
 - Stop the engine and relieve pressure before connecting or disconnecting lines.
 - Tighten all connections before starting the engine or pressurizing lines.
7. Do not modify or permit anyone else to modify or alter this tractor or any of its components or functions without first consulting a NEW HOLLAND AGRICULTURE Dealer.
8. The fuel oil in the injection system is under high pressure and can penetrate the skin. Unqualified persons should not remove or attempt to adjust a pump, injector, nozzle, or any other part of the fuel injection system. Failure to follow these instructions can result in serious injury.
9. Continuous long-term contact with used engine oil may cause skin cancer. Avoid prolonged contact with used engine oil. Wash skin promptly with soap and water.
10. Some components of your tractor, such as gaskets and friction surfaces (brake linings, clutch linings, etc.) may contain asbestos. Breathing asbestos dust is dangerous to your health. You are advised to have any maintenance or repair on such components carried out by an authorized NEW HOLLAND AGRICULTURE Dealer. However, if service operations are to be undertaken on parts that contain asbestos, the essential precautions listed below must be observed:
 - Work out of doors or in a well ventilated area.
 - Dust found on the tractor or produced during work on the tractor should be removed by extraction, not by blowing.
 - Dust waste should be dampened, placed in a sealed container, and marked to ensure safe disposal.
 - If any cutting, drilling, etc. is attempted on materials containing asbestos, the item should be dampened and only hand tools or low speed power tools used.

OPERATING THE TRACTOR

1. Before starting the tractor, apply the parking brake, place the PTO lever in the 'OFF' position, the lift control lever in the down position, the remote control valve levers in the neutral position, and the transmission in neutral.
2. Always sit in the tractor seat when starting the engine or operating controls. Do not start the engine or operate controls while standing beside the tractor.
3. Do not bypass the neutral start switches. Consult your NEW HOLLAND AGRICULTURE Dealer if your neutral start controls malfunction. Use jumper cables only in the recommended manner. Improper use can result in tractor runaway.
4. Avoid accidental contact with the gear shift lever while the engine is running, as this can cause unexpected tractor movement.
5. Before getting off the tractor, disengage the PTO, turn the engine off, and apply the parking brake. Never get off the tractor while it is in motion.
6. Do not park the tractor on a steep incline.
7. Do not operate the tractor engine in an enclosed building without adequate ventilation. Exhaust fumes can cause death or illness.
8. If the power steering or engine ceases operating, stop the tractor immediately.
9. Pull only from the drawbar or the lower link drawbar in the down position. Use only a drawbar pin that locks in place. Pulling from the tractor rear axle or any point above the axle may cause the tractor to upset.
10. If the front end of the tractor tends to rise when heavy implements are attached to the three-point hitch, install front end or front wheel weights. Do not operate the tractor with a light front end.
11. Always set the hydraulic selector lever in position control when attaching or transporting equipment. Ensure hydraulic couplers are properly mounted and will disconnect safely in case of accidental detachment of implement.
12. Do not leave equipment in the raised position.
13. Use the flasher/turn signal lights and SMV signs when traveling on public roads both day and night (unless prohibited by law).



Engine - 10

Engine and crankcase - 001

**Boomer 3040
Boomer 3045
Boomer 3050**

Engine - Remove Separating the Tractor at the Clutch Housing/Engine - 12x12 Transmission

Prior operation:

Cylinder head - Compression test (10.101).

Removal

1. Remove the negative (-) battery cable **(1)**, and the positive (+) battery cable **(2)**, from the battery.
2. Drain all of the hydraulic fluid from the transmission and the differential into a suitable container.
3. Disconnect the headlight wire harness plug and remove the hood from the tractor.
4. Remove the seat, and the seat base assembly from the tractor.
5. Remove the light bars from the fenders and the ROPS.
6. If equipped, remove the remote loader control valve **(1)**, and the connecting hydraulic tubes from the right fender.
7. Remove the left-hand and right-hand fenders from the tractor.
8. Remove the left-hand **(1)**, and right-hand **(2)**, rear hood side panels.
9. Disconnect and remove the throttle cable from the foot throttle control pedal, located on the right deck.
10. Remove the left and the right deck from the tractor.
11. Disconnect the throttle cable from the dash mounted throttle control lever.

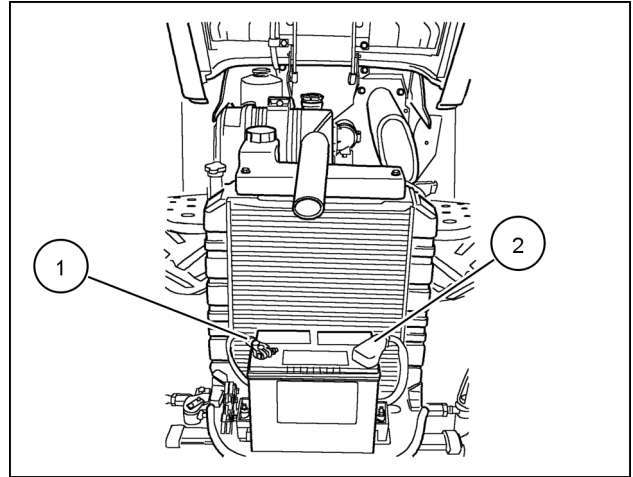

30997558A 1

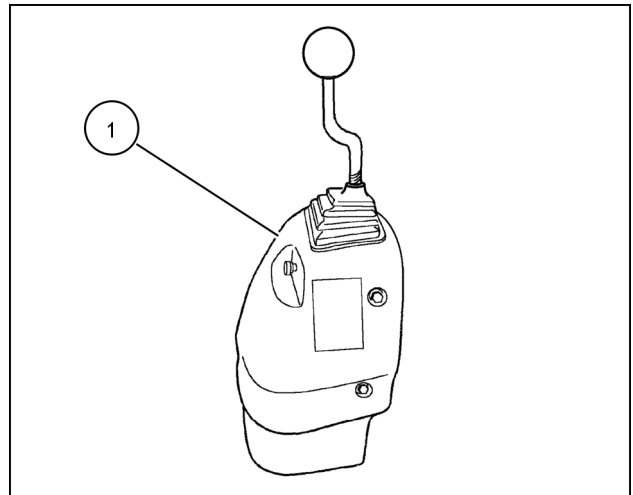

30997555A 2

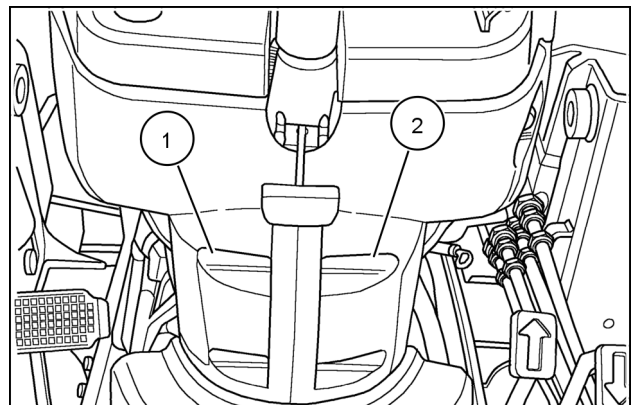

10000864 3

12. Loosen and remove the two or four instrument panel retaining screws (1). Remove the instrument panel (2), from the dash housing. Disconnect the wiring connector from the instrument panel. (Refer to figure 4 for 12 x 12 transmission panel and figure 5 for HST transmission panel).

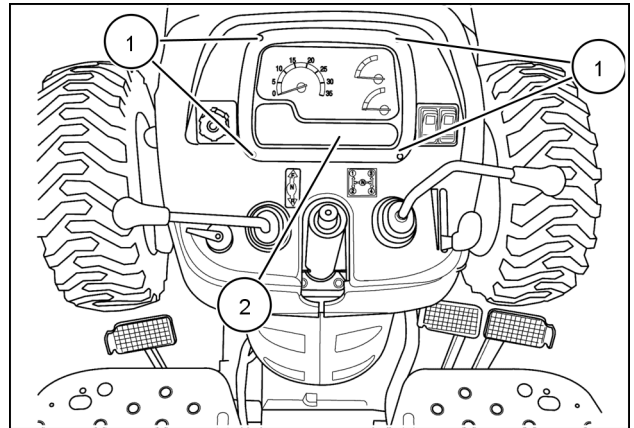

76075175 4

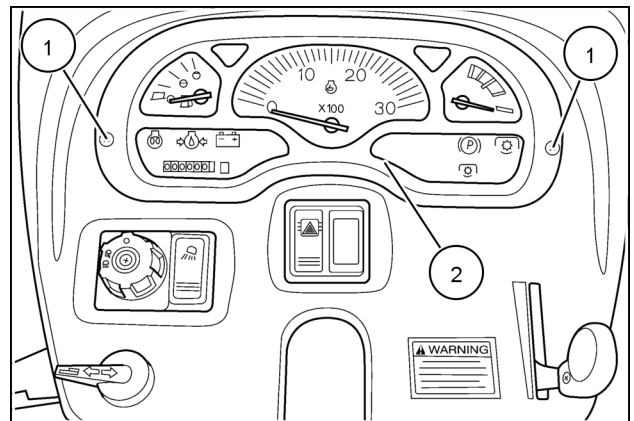

10034980 5

13. Drive the roll pin (1), from the lower shuttle shift shaft (2). Remove the retaining ring (3), and the roll pin (4), from the lower main shift shaft (5). Loosen and remove the retaining bolts (6), securing the main shift bracket (7), and the shuttle shift bracket (8), to the steering column (9). Remove the shift shaft assemblies by feeding the control levers down through the dash housing.
14. Remove the dash housing from the firewall. Disconnect the wiring connectors from the dash switches.
15. Disconnect the main wiring harness connector.

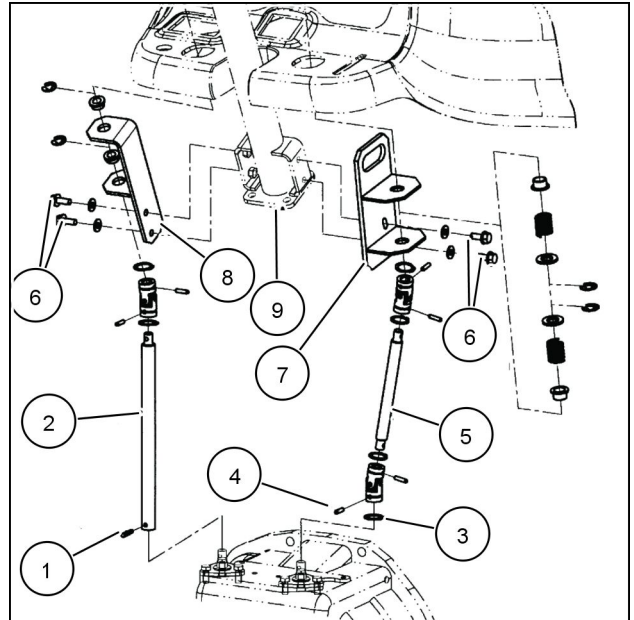

10996566 6

16. Remove the firewall support bracket (1), from the firewall (2), and the clutch housing (3).

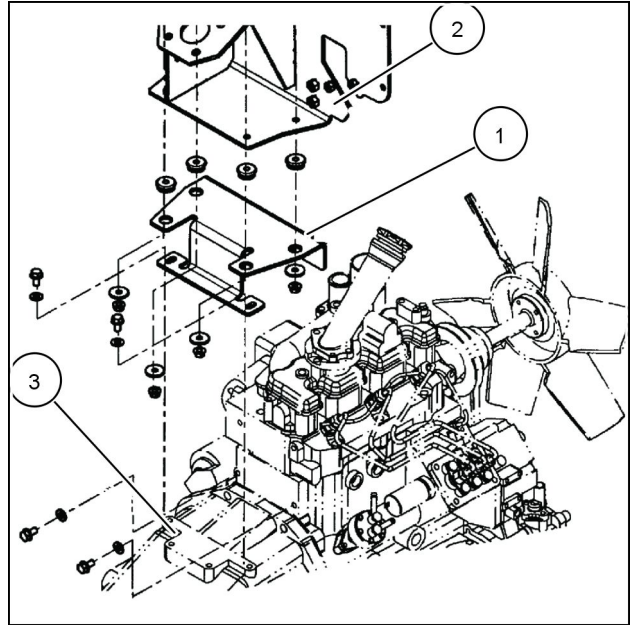

20000908 7

17. Remove the hydraulic system inlet tube (1) from the hydraulic pump (2).
18. Remove the hydraulic system pressure tube (3), from the hydraulic pump (2), and the diverter valve.

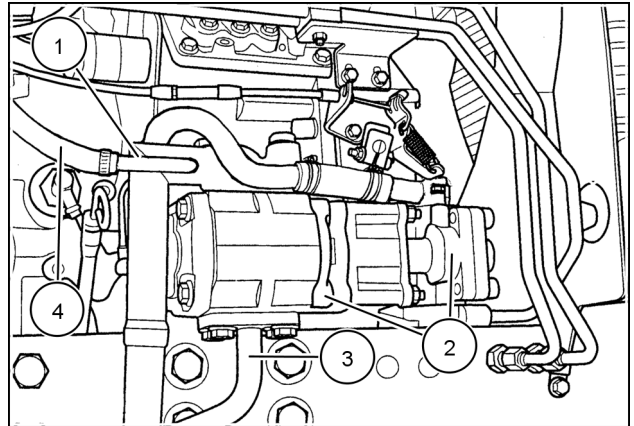

76075731 8

19. Disconnect the wires (1), on the starter (2), and remove the starter from the tractor.

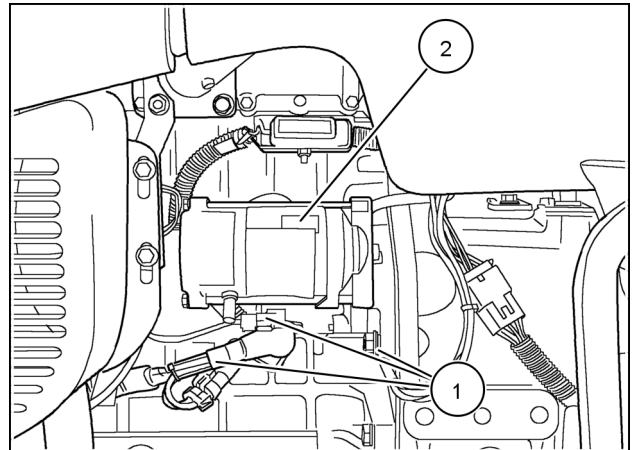

30997565 9

20. If equipped with FWD, remove the roll pins (1), from the front and rear of the FWD driveshaft (2), and remove the driveshaft from the tractor.
21. Drain the engine oil into a suitable container and remove the oil filter.

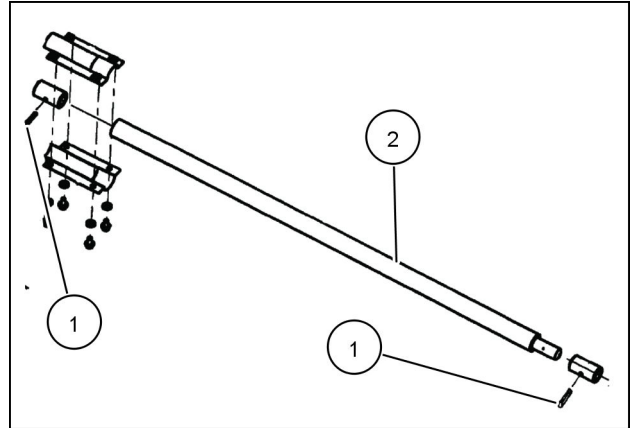

20000904 10

22. Remove the fuel supply (1), and return (2), lines from the fuel filter (3).
23. Drain the fuel tank into a suitable container.

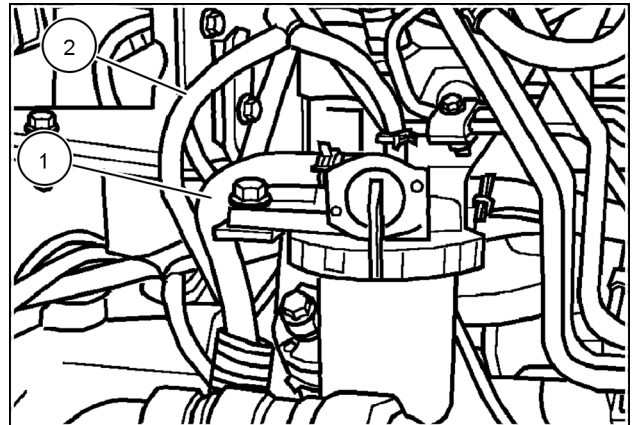

76075737 11

24. Attach a chain sling (1), to the two hoist eyes (2) and (3), on the engine.

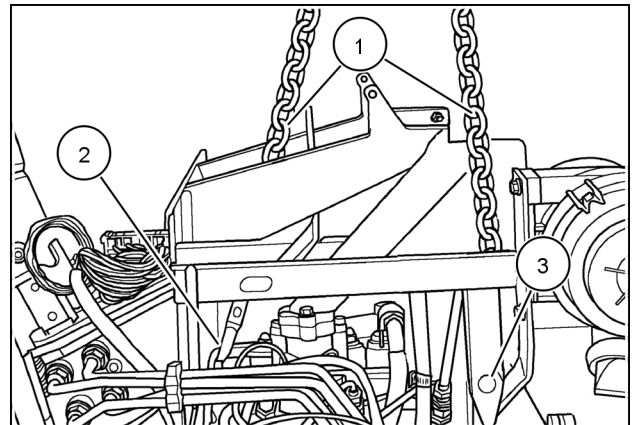

76075738 12

25. Attach a suitable hoist (1), to the chain sling (2).
- NOTE:** The hoist is used for supporting the engine and axle assembly, not for lifting.
26. Roll a floor jack under the tractor from the rear of the tractor, and place under the clutch housing. Raise the jack enough to support the drive train.

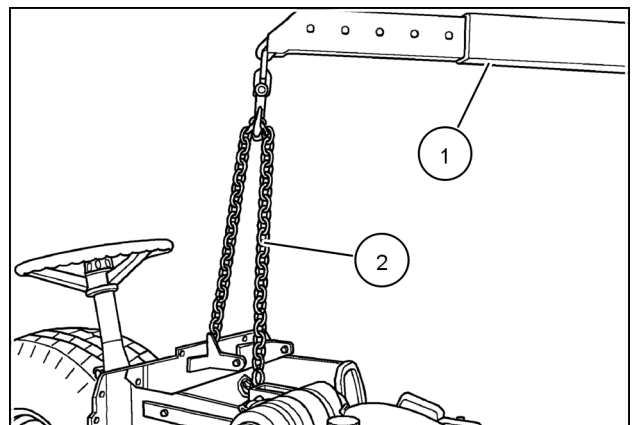

76075739 13

27. Remove the buckle-up bolts (1), that secure the engine (2), to the clutch housing (3).

NOTE: The hoist and/or the floor jack may need to be raised or lowered to allow the separation of the engine from the clutch housing.

28. Carefully roll the drive train away from the engine, using the floor jack for support.

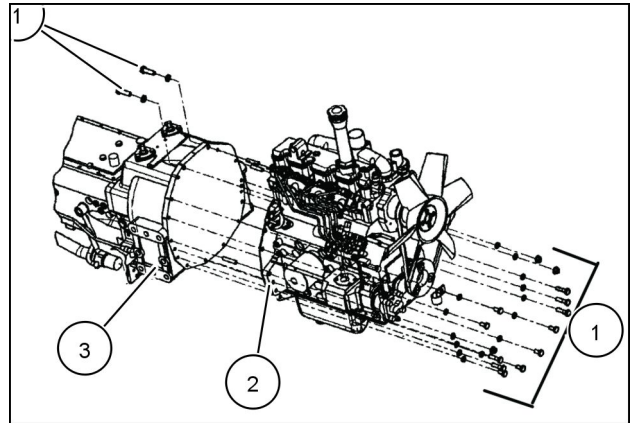

20000905 14

Next operation:

Engine - Remove Separating the Tractor at the Engine/Frame (10.001).

Engine - Remove Separating the Tractor at the Engine/Frame

⚠ WARNING

Heavy objects!

Lift and handle all heavy components using lifting equipment with adequate capacity. Always support units or parts with suitable slings or hooks. Make sure the work area is clear of all bystanders. Failure to comply could result in death or serious injury.

W0398A

Prior operation:

Engine - Remove Separating the Tractor at the Clutch Housing/Engine - 12x12 Transmission (10.001).

1. Use jack stands under the frame rails to support the front frame/engine assembly.
2. Remove the chain sling from the two hoist eyes on the engine.

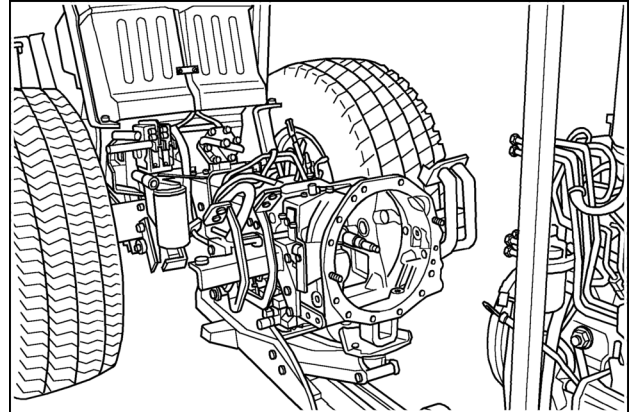

10000870 1

3. Remove the power steering lines (1), from the power steering control motor (2), the frame (3), and the power steering pump (4).

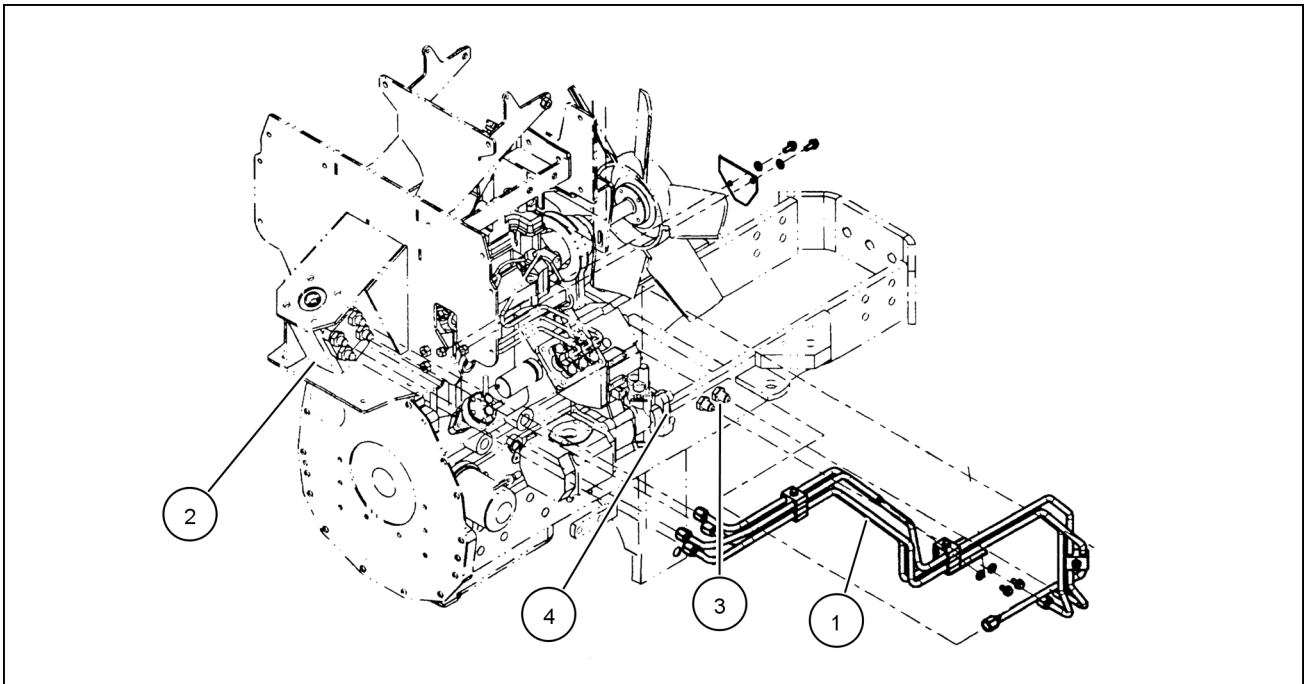

76075732 2



Suggest:

If the above button click is invalid.

Please download this document

first, and then click the above link

to download the complete manual.

Thank you so much for reading

4. Remove the air cleaner assembly (1), from the fire-wall (2).

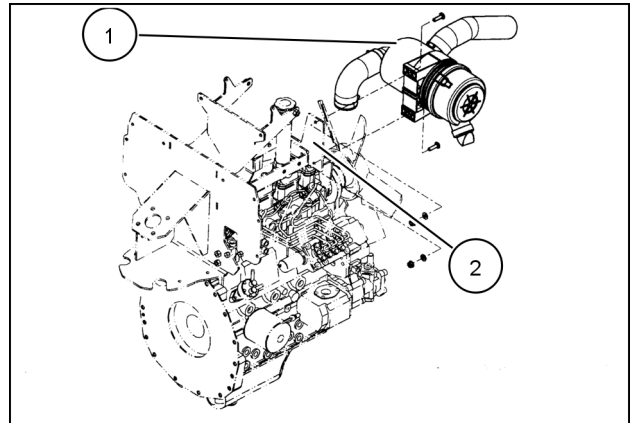

20002366 3

5. Remove the muffler guard (1), from the tractor.

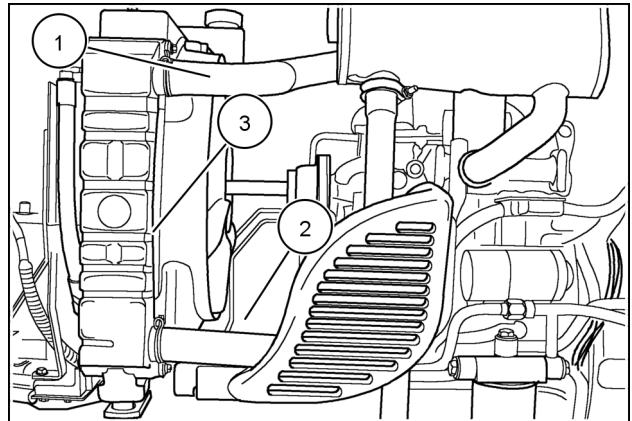

30996394 4

6. Remove the muffler (1), and the exhaust pipe (2), from the tractor.
7. Drain the coolant from the radiator into a suitable container.
8. Remove the top and the bottom radiator hoses.
9. Remove the radiator and the oil cooler (if equipped) from the tractor.

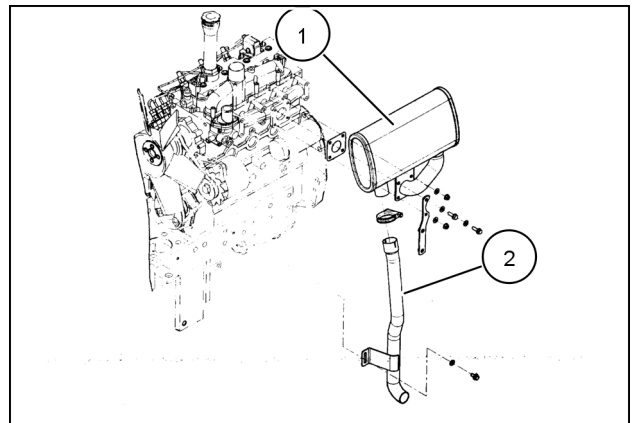

20002367 5

10. Remove the firewall (1), and the air cleaner mounting bracket (2), from the engine.
11. Attach a chain sling to the two hoist eyes on the engine.
12. Attach a suitable hoist to the chain sling, and raise the hoist enough to support the engine.

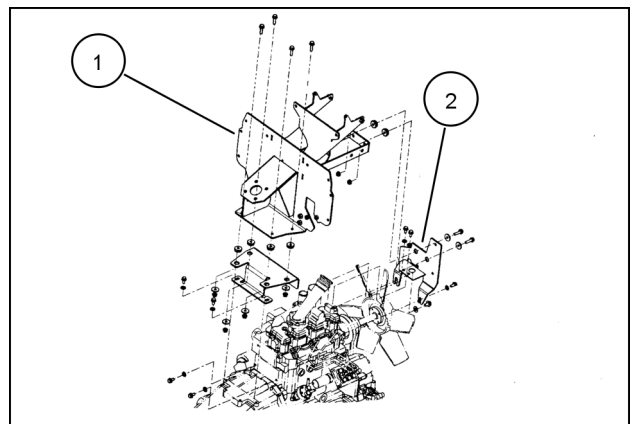

20002370 6

<https://www.ebooklibonline.com>

Hello dear friend!

Thank you very much for reading.

Enter the link into your browser.

The full manual is available for immediate download.

<https://www.ebooklibonline.com>