

SERVICE MANUAL

FR480 / FR550 / FR650 / FR780 Tier 4B (final)
FR850 Tier 2
Forage Harvester

Part number 47956032
1st edition English
February 2016





SERVICE MANUAL

FR480 Forage Cruiser Cursor 13, TIER 4B
FR550 Forage Cruiser Cursor 13, TIER 4B
FR650 Forage Cruiser Cursor 16, TIER 4B
FR780 Forage Cruiser Cursor 16, TIER 4B
FR850 Forage Cruiser Vector, TIER2

Link Product / Engine

Product	Market Product	Engine
FR480 Forage Cruiser Cursor 13, TIER 4B	North America	F3HFE613H*B007
FR550 Forage Cruiser Cursor 13, TIER 4B	North America	F3H FE613F*B007
FR650 Forage Cruiser Cursor 16, TIER 4B	North America	F3JFE613A*B005
FR780 Forage Cruiser Cursor 16, TIER 4B	North America	F3JFE613B*B006
FR850 Forage Cruiser Vector, TIER2	North America	FVAE2884X*B200

<https://www.ebooklibonline.com>

Hello dear friend!

Thank you very much for reading.

Enter the link into your browser.

The full manual is available for immediate download.

<https://www.ebooklibonline.com>

Contents

INTRODUCTION

Engine	10
[10.001] Engine and crankcase	10.1
[10.218] Fuel injection system.....	10.2
[10.400] Engine cooling system	10.3
[10.414] Fan and drive	10.4
[10.418] Rotary screen	10.5
Main gearbox and drive	14
[14.100] Main gearbox and drive	14.1
Transmission	21
[21.114] Mechanical transmission	21.1
[21.120] Gearbox.....	21.2
[21.130] Mechanical transmission external controls.....	21.3
[21.100] Mechanical transmission lubrication system	21.4
[21.145] Gearbox internal components.....	21.5
[21.182] Differential.....	21.6
Four-Wheel Drive (4WD) system	23
[23.101] Mechanical control	23.1
[23.304] Four-Wheel Drive (4WD) gearbox	23.2
Front axle system	25
[25.100] Powered front axle	25.1
[25.102] Front bevel gear set and differential	25.2
[25.310] Final drives	25.3
Rear axle system	27
[27.450] Rear-powered steerable axle	27.1
[27.550] Non-powered rear axle.....	27.2

Hydrostatic drive	29
[29.100] Transmission and steering hydrostatic control	29.1
[29.218] Pump and motor components.....	29.2
[29.202] Hydrostatic transmission	29.3
Brakes and controls	33
[33.202] Hydraulic service brakes	33.1
[33.110] Parking brake or parking lock	33.2
Hydraulic systems	35
[35.000] Hydraulic systems.....	35.1
[35.102] Pump control valves.....	35.2
[35.106] Variable displacement pump	35.3
[35.204] Remote control valves	35.4
[35.300] Reservoir, cooler, and filters.....	35.5
[35.359] Main control valve.....	35.6
[35.350] Safety and main relief valves	35.7
[35.600] High flow hydraulics	35.8
[35.410] Header or attachment height system	35.9
[35.602] Header or attachment leveling system	35.10
[35.514] Upper feed roll gearbox system.....	35.11
[35.516] Cutterhead drive system	35.12
[35.530] Spout rotation circuit	35.13
[35.532] Spout raising system	35.14
[35.534] Spout deflector system.....	35.15
Steering	41
[41.101] Steering control	41.1
[41.200] Hydraulic control components.....	41.2
[41.206] Pump	41.3
[41.216] Cylinders	41.4

[41.432] Autoguidance steering	41.5
Wheels	44
[44.511] Front wheels.....	44.1
[44.520] Rear wheels	44.2
Cab climate control	50
[50.100] Heating	50.1
[50.200] Air conditioning.....	50.2
Electrical systems	55
[55.000] Electrical system	55.1
[55.100] Harnesses and connectors.....	55.2
[55.015] Engine control system.....	55.3
[55.010] Fuel injection system.....	55.4
[55.014] Engine intake and exhaust system.....	55.5
[55.012] Engine cooling system	55.6
[55.013] Engine oil system	55.7
[55.301] Alternator.....	55.8
[55.512] Cab controls.....	55.9
[55.640] Electronic modules	55.10
[55.610] Ground speed control	55.11
[55.019] Hydrostatic drive control system	55.12
[55.051] Cab Heating, Ventilation, and Air-Conditioning (HVAC) controls.....	55.13
[55.050] Heating, Ventilation, and Air-Conditioning (HVAC) control system.....	55.14
[55.421] Feeding control system	55.15
[55.820] Chopping and cutting control systems	55.16
[55.830] Rotary screen drive and cleaning	55.17
[55.680] Autopilot/Autoguidance	55.18
[55.450] Ejecting control system	55.19
[55.408] Warning indicators, alarms, and instruments	55.20

[55.DTC] FAULT CODES	55.21
Attachments/Headers	58
[58.900] Belt feeding	58.1
Product feeding	60
[60.103] Lower feed rolls	60.1
[60.107] Upper feed rolls	60.2
[60.155] Metal detector	60.3
Chopping	64
[64.100] Cutterhead	64.1
[64.106] Drum	64.2
[64.130] Drum gearbox	64.3
[64.140] Sharpening system	64.4
[64.150] Shearbar	64.5
[64.160] Crop processor	64.6
[64.170] Transition channel/concave and lever	64.7
Ejection	70
[70.120] Blower	70.1
[70.140] Spout	70.2
Platform, cab, bodywork, and decals	90
[90.105] Machine shields and guards	90.1
[90.150] Cab	90.2
[90.151] Cab interior	90.3



INTRODUCTION

Safety rules

FR480 Forage Cruiser	NA
FR550 Forage Cruiser	NA
FR650 Forage Cruiser	NA
FR780 Forage Cruiser	NA
FR850 Forage Cruiser	NA

Personal safety





This is the safety alert symbol. It is used to alert you to potential personal injury hazards. Obey all safety messages that follow this symbol to avoid possible death or injury.

Throughout this manual you will find the signal words DANGER, WARNING, and CAUTION followed by special instructions. These precautions are intended for the personal safety of you and those working with you.

Read and understand all the safety messages in this manual before you operate or service the machine.

 DANGER indicates a hazardous situation that, if not avoided, will result in death or serious injury.

 WARNING indicates a hazardous situation that, if not avoided, could result in death or serious injury.

 CAUTION indicates a hazardous situation that, if not avoided, could result in minor or moderate injury.

FAILURE TO FOLLOW DANGER, WARNING, AND CAUTION MESSAGES COULD RESULT IN DEATH OR SERIOUS INJURY.

Machine safety

NOTICE: Notice indicates a situation that, if not avoided, could result in machine or property damage.

Throughout this manual you will find the signal word Notice followed by special instructions to prevent machine or property damage. The word Notice is used to address practices not related to personal safety.

Information

NOTE: Note indicates additional information that clarifies steps, procedures, or other information in this manual.

Throughout this manual you will find the word Note followed by additional information about a step, procedure, or other information in the manual. The word Note is not intended to address personal safety or property damage.

Safety rules - Ecology and the environment

FR480 Forage Cruiser	NA
FR550 Forage Cruiser	NA
FR650 Forage Cruiser	NA
FR780 Forage Cruiser	NA
FR850 Forage Cruiser	NA

Soil, air, and water quality is important for all industries and life in general. When legislation does not yet rule the treatment of some of the substances that advanced technology requires, sound judgment should govern the use and disposal of products of a chemical and petrochemical nature.

Familiarize yourself with the relative legislation applicable to your country, and make sure that you understand this legislation. Where no legislation exists, obtain information from suppliers of oils, filters, batteries, fuels, anti-freeze, cleaning agents, etc., with regard to the effect of these substances on man and nature and how to safely store, use, and dispose of these substances.

Helpful hints

- Avoid the use of cans or other inappropriate pressurized fuel delivery systems to fill tanks. Such delivery systems may cause considerable spillage.
- In general, avoid skin contact with all fuels, oils, acids, solvents, etc. Most of these products contain substances that may be harmful to your health.
- Modern oils contain additives. Do not burn contaminated fuels and or waste oils in ordinary heating systems.
- Avoid spillage when you drain fluids such as used engine coolant mixtures, engine oil, hydraulic fluid, brake fluid, etc. Do not mix drained brake fluids or fuels with lubricants. Store all drained fluids safely until you can dispose of the fluids in a proper way that complies with all local legislation and available resources.
- Do not allow coolant mixtures to get into the soil. Collect and dispose of coolant mixtures properly.
- The air-conditioning system contains gases that should not be released into the atmosphere. Consult an air-conditioning specialist or use a special extractor to recharge the system properly.
- Repair any leaks or defects in the engine cooling system or hydraulic system immediately.
- Do not increase the pressure in a pressurized circuit as this may lead to a component failure.
- Protect hoses during welding. Penetrating weld splatter may burn a hole or weaken hoses, allowing the loss of oils, coolant, etc.

Battery recycling

Batteries and electric accumulators contain several substances that can have a harmful effect on the environment if the batteries are not properly recycled after use. Improper disposal of batteries can contaminate the soil, groundwater, and waterways. NEW HOLLAND strongly recommends that you return all used batteries to a NEW HOLLAND dealer, who will dispose of the used batteries or recycle the used batteries properly. In some countries, this is a legal requirement.



Mandatory battery recycling

NOTE: The following requirements are mandatory in Brazil.

Batteries are made of lead plates and a sulfuric acid solution. Because batteries contain heavy metals such as lead, CONAMA Resolution 401/2008 requires you to return all used batteries to the battery dealer when you replace any batteries. Do not dispose of batteries in your household garbage.

Points of sale are obliged to:

- Accept the return of your used batteries
- Store the returned batteries in a suitable location
- Send the returned batteries to the battery manufacturer for recycling

Safety rules

FR480 Forage Cruiser	NA
FR550 Forage Cruiser	NA
FR650 Forage Cruiser	NA
FR780 Forage Cruiser	NA
FR850 Forage Cruiser	NA

LEGAL OBLIGATIONS

This machine may be equipped with special guarding or other devices in compliance with local legislation. Some of these require active use by the operator. Therefore, check local legislations on the usage of this machine.

ACCIDENT PREVENTION

Most accidents or injuries that occur in workshops are the result of non compliance to simple and fundamental safety principles. For this reason, IN MOST CASES THESE ACCIDENTS CAN BE AVOIDED by applying the fundamental safety principles, acting with the necessary caution and care.

Accidents may occur with all types of machine, regardless of how well the machine in question was designed and built.

CAUTION

Unexpected machine movement!

1. Disengage all drives.
 2. Engage parking brake.
 3. Lower all attachments to the ground, or raise and engage all safety locks.
 4. Shut off engine.
 5. Remove key from key switch.
 6. Switch off battery key, if installed.
 7. Wait for all machine movement to stop.
- Failure to comply could result in minor or moderate injury.

C0038A

SAFETY REQUIREMENTS FOR FLUID POWER SYSTEMS AND COMPONENTS - HYDRAULICS

- Flexible hose assemblies must not be constructed from hoses which have been previously used as part of a hose assembly.
- Do not weld hydraulic pipes: when flexible hoses or piping are damaged, replace them immediately.
- It is forbidden to modify a hydraulic accumulator by machining, welding or any other way.
- Before removing hydraulic accumulators for servicing, the liquid pressure in the accumulators must be reduced to zero.
- Pressure check on hydraulic accumulators must be carried out by a method recommended by the accumulator manufacturer.
- Take care not to exceed the maximum allowed pressure of the accumulator. After any check or adjustment, check for leakages or gas in the hoses or tubes.

SAFETY RULES

General guidelines

- Carefully follow specified repair and maintenance procedures.
- When appropriate, use P.P.E (Personal Protective Equipment)
- Do not wear rings, wristwatches, jewellery, unbuttoned or loose articles of clothing such as: ties, torn clothing, scarves, open jackets or shirts with open zips that may remain entangled in moving parts. It is advised to wear approved safety clothing, e.g.: non-slip footwear, gloves, safety goggles, helmets, etc.

INTRODUCTION

- Do not carry out repair operations with someone sitting in the driver's seat, unless the person is a trained technician who is assisting with the operation in question.
- Do not operate the machine or use any of the implements from different positions, other than the driver's seat.
- Do not carry out operations on the machine with the engine running, unless specifically indicated.
- Bring all hydraulic cylinders to the home positions (down, retracted, etc.) before engine shut down.
- Stop the engine and check that the hydraulic circuits are pressure-free before removing caps, covers, valves, etc.
- All repair and maintenance operations must be carried out using extreme care and attention.
- Service steps and platforms used in the workshop or elsewhere should be built according to the applicable standards and legislation.
- Disconnect the Power Take-Off (PTO) and label the controls to indicate that the machine is being serviced.
- Brakes are inoperative when manually released for repair or maintenance purposes. Use blocks or similar devices to secure the machine in these conditions.
- Only use specified towing points for towing the machine. Connect parts carefully. Make sure that all pins and/or locks are secured in position before applying traction. Never remain near the towing bars, cables or chains that are operating under load.
- When loading or unloading the machine from the trailer (or other means of transport), select a flat area capable of sustaining the trailer or truck wheels. Firmly secure the machine to the truck or trailer and lock the wheels in the position used by the carrier.
- Electric heaters, battery-chargers and similar equipment must only be powered by auxiliary power supplies with efficient ground insulation to avoid electrical shock hazards.
- Always use suitable hoisting or lifting devices when raising or moving heavy parts.
- Keep bystanders away.
- Never use gasoline, diesel oil or other inflammable liquids as cleaning agents. Use non-inflammable, non toxic commercially available solvents.
- Wear safety goggles with side guards when cleaning parts with compressed air.
- Never use open flames for lighting when working on the machine or checking for leaks.
- When carrying out checks with the engine running, request the assistance of an operator in the driver's seat. The operator must maintain visual contact with the service technician at all times.
- If operating outside the workshop, position the machine on a flat surface and lock in position. If working on a slope, lock the machine in position. Move to a flat area as soon as is safely possible.
- Maintenance and repair operations must be carried out in a clean and dry area. Clean up any water or oil spillage immediately.
- Do not create piles of oil or grease-soaked rags as they represent a serious fire hazard. Always store rags in a closed metal container.
- Before engaging the machine, make sure that there are no persons within the machine or implement range of action.
- Empty your pockets of all objects that may fall accidentally unobserved into the machine inner compartments.
- When metal parts are sticking out, use protective goggles or goggles with side guards, helmets, special footwear and gloves.
- When welding, use protective safety devices: tinted safety goggles, helmets, special overalls, gloves and footwear. All persons present in the area where welding is taking place must wear tinted goggles. **NEVER LOOK DIRECTLY AT THE WELDING ARC WITHOUT SUITABLE EYE PROTECTION.**



SERVICE MANUAL

Engine

FR480 Forage Cruiser Cursor 13, TIER 4B
FR550 Forage Cruiser Cursor 13, TIER 4B
FR650 Forage Cruiser Cursor 16, TIER 4B
FR780 Forage Cruiser Cursor 16, TIER 4B
FR850 Forage Cruiser Vector, TIER2

Engine - Remove

FR480 Forage Cruiser	NA
FR550 Forage Cruiser	NA
FR650 Forage Cruiser	NA
FR780 Forage Cruiser	NA

⚠ DANGER

Heavy objects!

Lift and handle all heavy components using lifting equipment with adequate capacity. Always support units or parts with suitable slings or hooks. Make sure the work area is clear of all bystanders.

Failure to comply will result in death or serious injury.

D0926A

⚠ WARNING

Fall hazard!

Use a sturdy platform when working above ground level.

Failure to comply could result in death or serious injury.

W0926A

⚠ WARNING

Jack stands can slip or fall over. Dropping, tipping, or slipping of machine or its components is possible.

DO NOT work under a vehicle supported by jack stands only. Park machine on a level surface. Block wheels. Support machine with safety stands.

Failure to comply could result in death or serious injury.

W0069A

NOTE: The engine removal is done on FR480 but the instructions and figures can be used as a guideline for all other models, except for the FR850.

NOTE: When disconnecting fluid lines, have a suitable container available to collect any residual fluids. Use stops and/or plugs to prevent fluids spill and to protect against dirt ingress.

Shieldings

1. Move the spout to the extreme left or right.
2. Remove both the side shieldings. See **Side shields - Remove (90.105)**.
3. Remove the rear fenders.
4. For better access remove the steering wheels. See **Rear wheel - Remove (44.520)**.

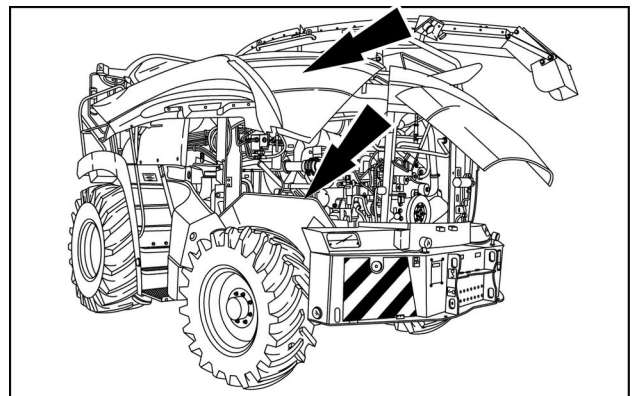

ZEIL15FR00087AA 1

5. Remove the rear shield.

- Support the rear shield (2). Ask the assistance of a second person or use a suitable lifting device.
- Lift up the bottom clip from the gas strut (3), then remove the gas strut (3) from the pivot bolt.
- Remove the hardware (1).
- Remove the rear shield (2).

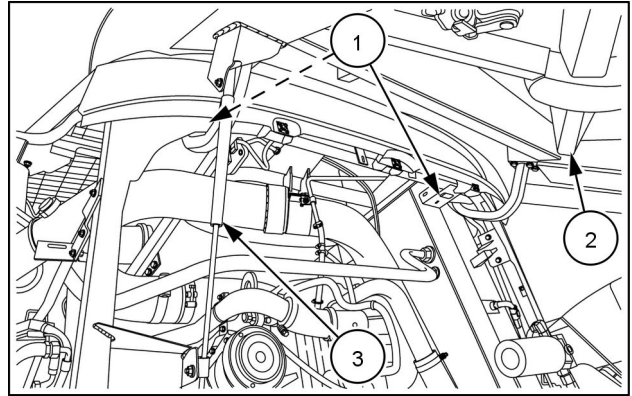

ZEIL15FR00085AA 2

6. Remove the hardware (4) (six in total) and remove the top rear shield (5).

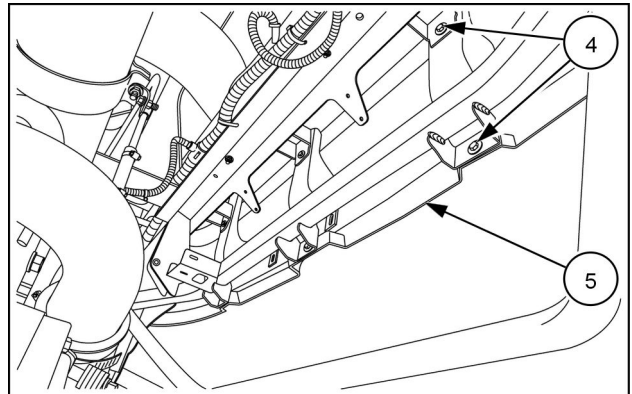

ZEIL15FR00086AA 3

Discharge the air-conditioning circuit

7. Discharge the air-conditioning circuit. See chapter "Air Conditioning" in the service manual.

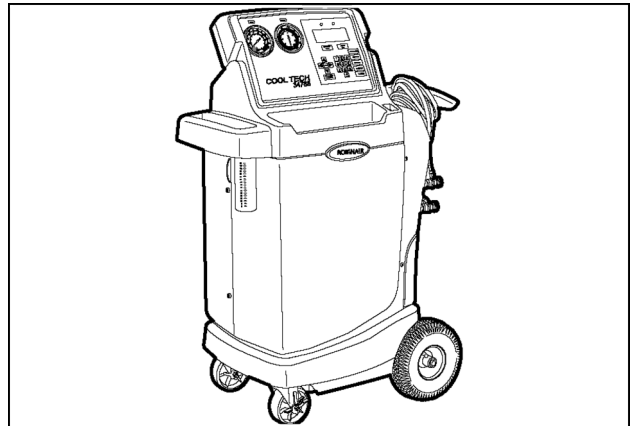

34788-300 4

Drain Fluids

8. Drain the hydraulic oil reservoir.

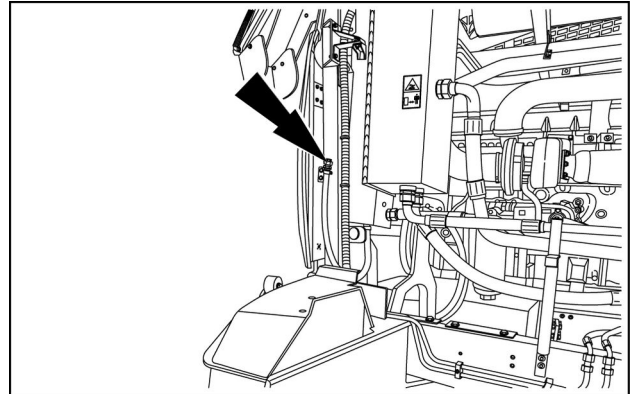

ZEIL15FR00090AA 5

9. Drain the engine coolant:

- Engine coolant radiator

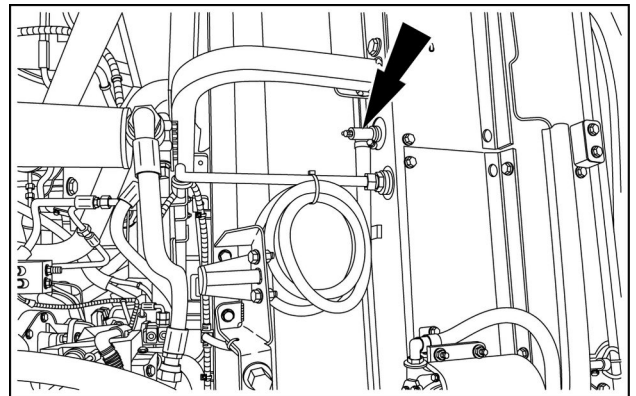

ZEIL15FR00088AA 6

- Engine coolant intake. Close the tap, remove the hose, drain coolant, open the tap and drain fluid.
- Engine coolant outlet. Close the tap, remove the hose, drain coolant, open the tap and drain fluid.

NOTE: Still some coolant in the tubes.

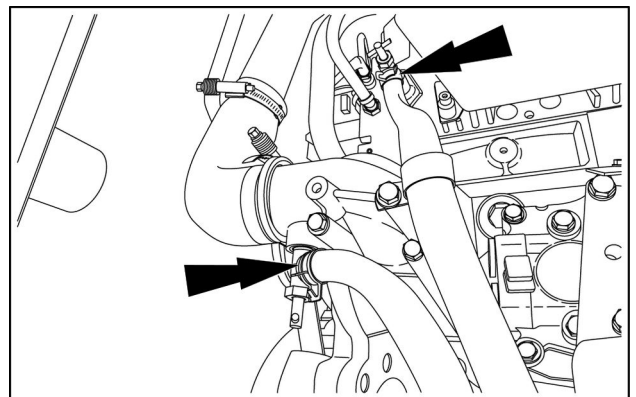

ZEIL15FR00089AA 7

Wiring harnesses

10. On the left-hand side of the machine, remove all the straps and disconnect all the connectors of the two wiring harness branches (see arrows) going down of the wiring harness (6) and lay the wiring harness branches on top of the roof assembly. See **Wiring harnesses - Overview (55.100)** in the service manual.

NOTE: Remove the air filter clogging sensor and the main gearbox rpm sensor to prevent damage.

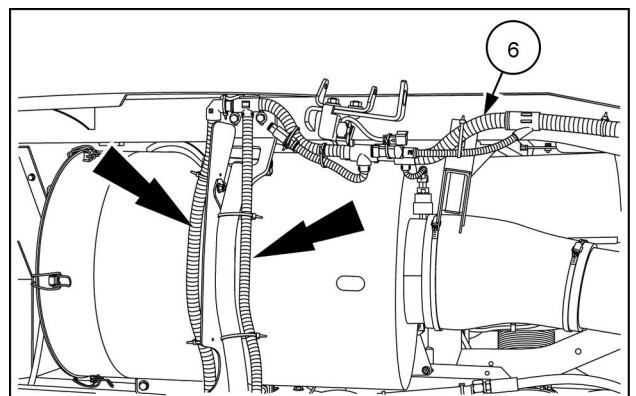

ZEIL15FR00198AA 8



Suggest:

If the above button click is invalid.

Please download this document

first, and then click the above link

to download the complete manual.

Thank you so much for reading

11. Remove all the straps and disconnect all the connectors of the wiring harness branch (see arrow) going down of the wiring harness **(6)** and lay the wiring harness branch on top of the roof assembly. See the location diagram in the service manual.

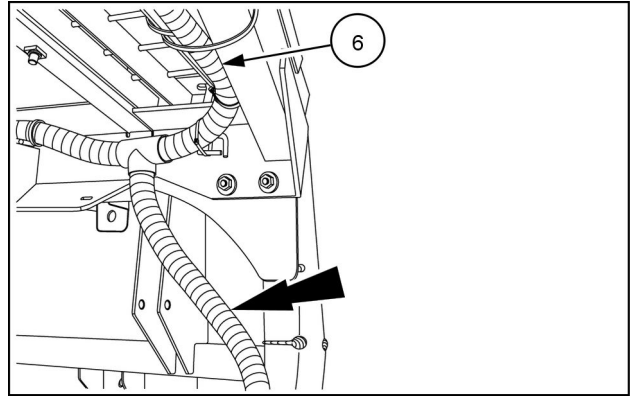

ZEIL15FR00120AA 9

12. On the left hand side of the machine, remove all the straps and disconnect all the connectors of the wiring harness branch (see arrow) going down of the wiring harness **(6)** and lay the wiring harness branch on top of the roof assembly. See the location diagram in the service manual.

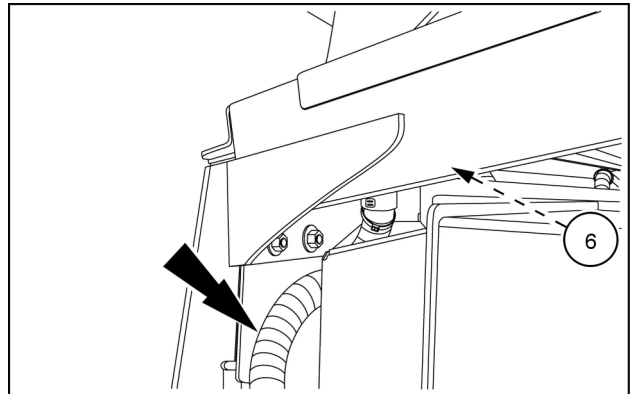

ZEIL15FR00121AA 10

13. On the right-hand side of the machine, disconnect the connector **(7A)**.

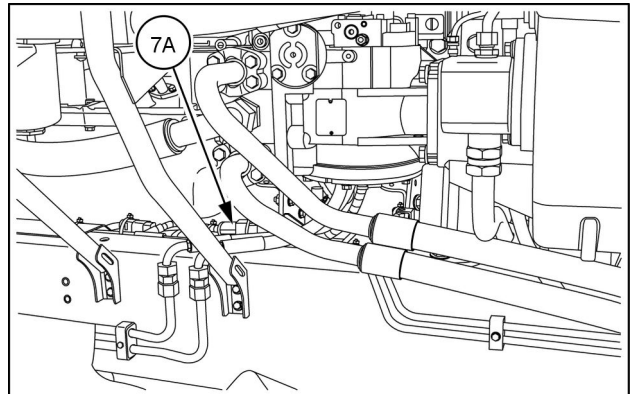

ZEIL15FR00132AA 11

14. Disconnect the ground cable **(8)** from the engine.
 15. Disconnect the positive lead **(9A)** from the starter motor.

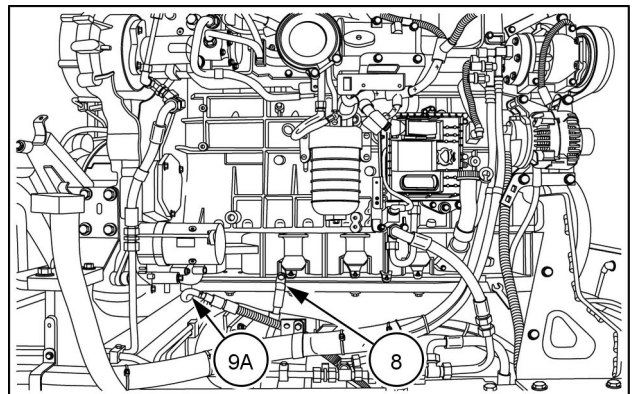

ZEIL15FR00148AA 12

<https://www.ebooklibonline.com>

Hello dear friend!

Thank you very much for reading.

Enter the link into your browser.

The full manual is available for immediate download.

<https://www.ebooklibonline.com>