

# **FORD**

## **RIDING MOWER TRACTOR**

**MODELS: 09GN-2051/2052/2053  
40205130**

# **REPAIR MANUAL**

Reprinted

# TABLE OF CONTENTS

<b>RIDER MOWER TRACTORS R8 &amp; R11 (Model 09GN-2051/2052/2053)</b>	<b>PAGE</b>
INTRODUCTION AND SAFETY .....	1
LUBRICATION AND MAINTENANCE .....	2
ADJUSTMENT AND SERVICING	
Engine .....	3
Mower Deck	
Mower Deck Removal And Replacement .....	4
Blade Removal And Replacement .....	5
Blade Sharpening And Balancing .....	6
Mower Spindle Removal And Replacement .....	6
Mower Drive Brake Adjustment .....	7
Belts	
Mower Drive Belt Adjustment .....	8
Mower Drive Belt Replacement .....	9
Traction Drive Belt Adjustment .....	9
Traction Drive Belt Replacement .....	9
Traction Drive Brake	
Brake Adjustment .....	10
Brake Pad Replacement .....	11
Traction Drive Chain	
Chain Adjustment .....	12
Chain Replacement .....	12
Differential Removal And Replacement .....	13
Transmission Removal And Replacement .....	13
Transmission Shift Linkage Adjustment .....	14
Throttle Control Removal And Replacement .....	15
Electrical System	
System Functions .....	16
Battery .....	17
Solenoid .....	17
Ignition Switch .....	18
Interlock Switch System Check .....	19
Fuse .....	21
Wiring Diagram .....	22
Electric Start System .....	22
Recoil Start System .....	23
TROUBLE-SHOOTING .....	24
BOLT TORQUE SPECIFICATIONS .....	26

**IMPORTANT:** The replacement of any part on this product by other than the manufacturer's authorized replacement part may adversely affect the performance, durability or safety of this product.

The manufacturer reserves the right to make changes on and to add improvements upon its products at any time without notice or obligation. The manufacturer also reserves the right to discontinue manufacture of any product at its discretion at any time.

Notice to Serviceman in the State of California — The engine on this unit is NOT equipped with a spark arresting muffler.

**IMPORTANT:** USE OR OPERATION OF THIS ENGINE ON ANY FOREST COVERED, BRUSH COVERED, OR GRASS COVERED LAND WITHOUT A STATE APPROVED SPARK ARRESTOR IN EFFECTIVE WORKING ORDER CONSTITUTES A VIOLATION OF THE LAW OF THE STATE OF CALIFORNIA.

# REAR ENGINE RIDER

## INTRODUCTION

This manual contains service and maintenance instructions for Rear Engine Riders. It has been prepared to provide the information the serviceman needs to correctly service and maintain a rear engine rider. All sections of this manual should be carefully studied by the serviceman before beginning to work on the rider.

ALL WARNINGS used throughout this manual should be heeded and followed very closely. Failure to obey these rules could result in personal injury or death to yourself or others.

All references made to the left side, right side, front and rear are given from the operator's position.

## SAFETY



**Safety is No Accident . . . . . Be Alert!**

**This symbol is used to attract your attention to the safety precautions that should be understood by the servicemen to avoid accidents.**

Please read and follow these instructions on safety procedures before servicing the rider.

### PERSONAL CONSIDERATIONS

1. Never let shop rags, used for cleaning, lay around to become fire hazards.
2. Always use safety glasses when servicing or inspecting the rider.
3. Do not wear loose fitting clothing that might get caught in moving parts. Also, keep hands and feet away from moving parts.
4. Be certain that the work bench or support being used is strong enough. The weight of the part plus the force applied to it during assembly or disassembly may put a great strain on the bench or support.
5. Use jack stands or blocks to hold up the unit in any potentially dangerous positions required for access. Do not rely only on jack for support.

### EQUIPMENT CONSIDERATIONS

1. Always disconnect spark plug wire and secure away from spark plug. This **must** be performed every time any servicing is done and will prevent accidental starting of engine.
2. Always store gasoline or flammable solvents used for cleaning in closed containers specifically designed for that purpose.
3. Before cleaning, servicing or inspecting rider, make certain all moving parts have stopped and engine and exhaust assemblies have cooled down.

4. Never operate rider without proper guards, plates or other safety protective devices in place.
5. Never store rider with gasoline in the tank inside a building where fumes may reach an open flame or spark. Allow engine to cool before storing in any enclosure.
6. Disengage power to attachment(s) and stop engine before servicing, repairing or making any adjustments.
7. Disengage power to attachment(s) when transporting or not in use.
8. Take all possible precautions when leaving the vehicle unattended, such as disengaging the power-take-off, lowering the attachment, shifting into neutral, setting the parking brake, stopping the engine and removing the key.
9. Do not change governor setting or over speed the engine.
10. Be certain that any part being removed is properly supported or held to prevent injury or damage.

### OPERATIONAL CONSIDERATIONS

1. Do not start or run the engine indoors. Fumes from engine exhaust can kill.
2. Disengage all clutches and place gear shift lever in neutral before attempting to start engine.
3. Be sure that all parts are securely fastened before starting rider.
4. Be sure all tools and cleaning materials are removed before starting rider.
5. If the equipment should start to vibrate abnormally, stop engine and check immediately for the cause. Vibration is generally a warning of trouble.
6. If test running is required, make sure you are thoroughly familiar with the complete operation of the rider. Know how to stop the rider.
7. Never operate machine at high transport speeds on slippery surfaces. Use care when backing.
8. Never operate without good visibility or light.

Whenever you see this symbol  it means:  
**ATTENTION! BECOME ALERT! YOUR SAFETY IS INVOLVED!**

**<https://www.ebooklibonline.com>**

Hello dear friend!

Thank you very much for reading.

Enter the link into your browser.

The full manual is available for immediate download.

**<https://www.ebooklibonline.com>**

## IDENTIFICATION PLATE LOCATION:

The rear engine rider model and serial number identification plate is located on left side of main frame just behind mower deck lift lever. (Fig. 1)

Refer to engine manufacturer's engine literature for location of engine model and serial number.

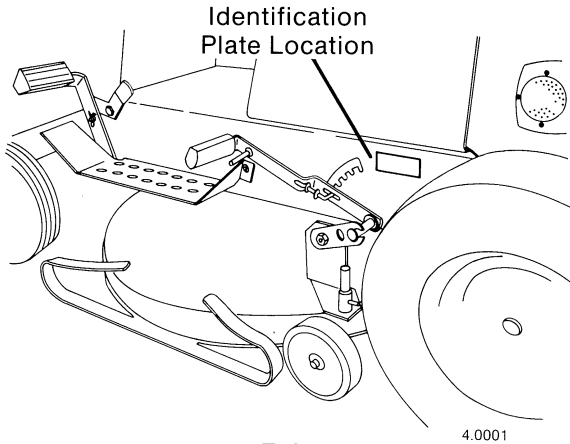

FIG. 1

## LUBRICATION AND MAINTENANCE

### LUBRICATION:

1. Engine - Check engine oil level before each engine operation. Change engine oil every 25 operating hours. Consult engine manufacturer's service manual for all lubrication and maintenance specifications.
2. Front Wheels - Grease with NLGI Grade 2 Lithium base EP grease (Ford 1T-M1C137-B), every 25 operating hours. (Fig. 2)

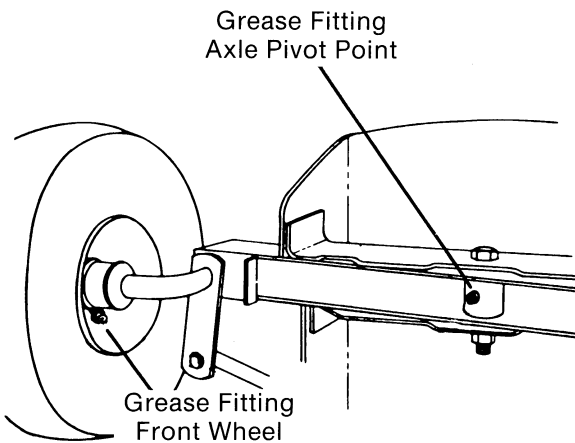

FIG. 2

RE1016

3. Front Axle Pivot Point - Grease with NLGI Grade 2 Lithium base EP grease (Ford 1T-M1C137-B), every 25 operating hours. (Fig. 2)
4. Mower Deck Gauge Wheels - Oil shaft liberally, turning wheels to work oil in every 25 operating hours with SAE 30 oil. (Fig. 3)

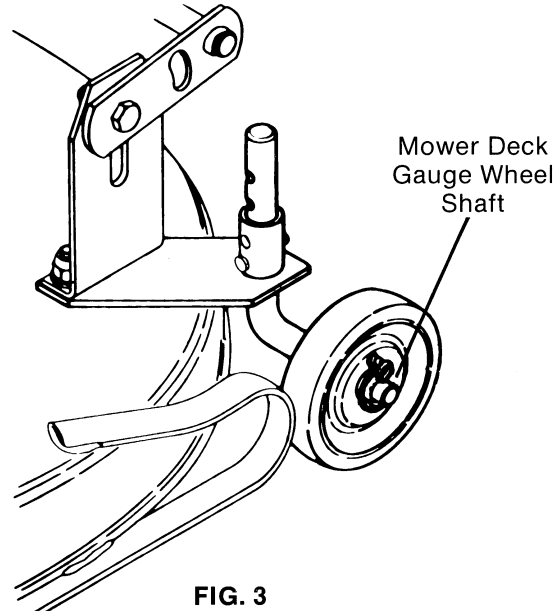

FIG. 3

5. All Other Pivot Points - Clean all pivot points and linkages and oil with SAE 30 oil every 25 operating hours.
6. Transmission and Differential - The transmission and differential are filled for life and should not require additional lubrication. Make periodic visual inspections for damage or leaks every 100 operating hours. If damage or leaks occur, consult transmission or differential manufacturer's service manual for proper lubrication and maintenance specifications. (transmission lubricant type - E.P. Lithium Grease, 12 ounces).

### MAINTENANCE:

1. General - Make a visual inspection for loose or damaged parts. Damaged parts should be repaired or replaced.
2. Battery - Terminals should be tight and free of corrosion. Retainer rod should be snug over battery. Top of battery should be clean and dry. Check level of electrolyte. Add clean distilled water as needed.
3. Belts - Inspect for cracking, excessive wear and for proper tension. Refer to "ADJUSTMENTS AND SERVICING" section.
4. Tire Pressures - Recommended pressure for both front and rear tires is 14 p.s.i.

# ADJUSTMENT AND SERVICING

## ENGINE:

1. Refer to Engine Manufacturer's Service Manual for all adjustments and servicing information.
2. Maximum engine RPM high speed operation no load range is 3400 RPM to 3600 RPM.

### 3. Engine Removal —

**WARNING:** To avoid accidental starting, remove spark plug wire and secure away from spark plug.

- A. Set parking brake and drain gas from fuel tank if tank is more than half full.
- B. Turn ignition key "OFF". Remove battery retainer rod from battery and slide battery forward.

**WARNING:** To avoid burns, be careful not to short the positive (+) terminal of battery to the rider when removing from mounting.

- C. Disconnect both battery cables from battery. Disconnect negative (-) terminal first. Remove battery from rider.
- D. Disconnect throttle cable at engine, by loosening throttle cable clamp screw enough so that cable can be removed. Disconnect cable end from throttle speed control block. (Fig. 4)

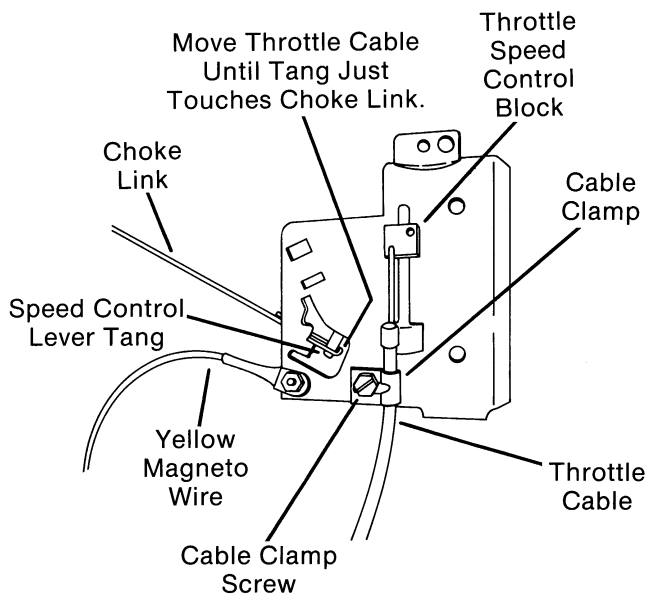

FIG. 4

- E. Disconnect yellow wire to magneto at left rear corner of engine next to throttle cable clamp screw. (Fig. 4)

- F. (Electric start only) Disconnect red starter wire and red alternator wire at connector at right rear corner of engine. (Fig. 5)

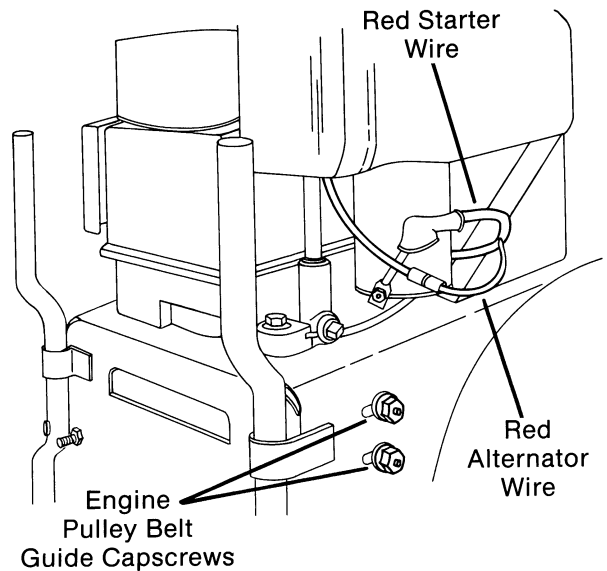

FIG. 5

**WARNING:** To avoid personal injury when raising or lowering the rear engine rider, make sure you are capable of handling the weight. When in doubt get assistance.

- G. Raise front of rider up and stand on rear support bars. (Fig. 6)

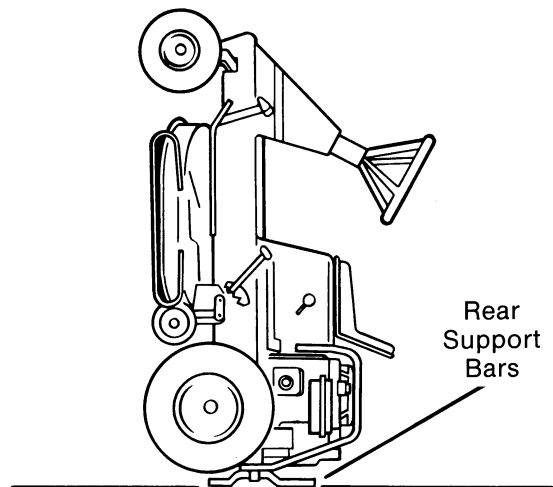

FIG. 6

- H. Remove carriage bolts, washers and locknuts securing engine pulley belt guide and remove belt guide. (Fig. 5)
- I. With mower drive lever disengaged, remove drive belt from engine pulley.

- J. Remove nut securing traction drive idler pulley to idler bracket and remove pulley. (Fig. 7) Slip traction drive belt off engine pulley towards bottom of engine.

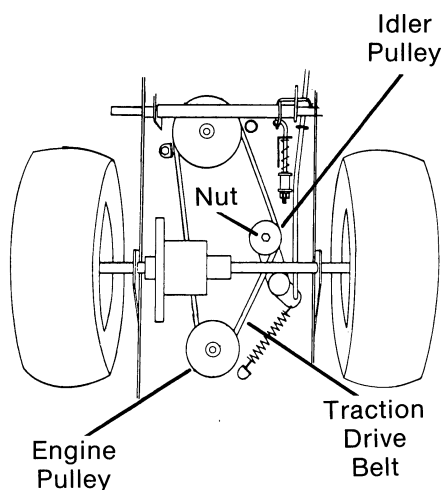

FIG. 7

- K. Lower front of rider back to the ground.  
 L. Remove four bolts, locknuts and star washers securing engine to main frame.  
 M. Lift engine slightly and move forward. Reach under rear of main frame and remove traction drive belt from engine pulley.  
 N. Lift engine off main frame.

NOTE: Observe location and quantity of engine spacing washers under each mounting location.

- O. Remove engine pulley capscrew and remove engine pulley from crankshaft.  
 P. To replace engine, reverse above procedure until you reach the point of connecting the throttle control cable. Then follow this adjustment procedure: Move throttle control lever up to the "FULL FAST" position (which is the detent before "START" position is reached). (Fig. 8) Attach end of throttle control cable to throttle speed control block and slip cable under cable clamp. Push throttle cable up until tang on speed control lever just touches choke link, as shown in (Fig. 4). Tighten cable clamp screw.

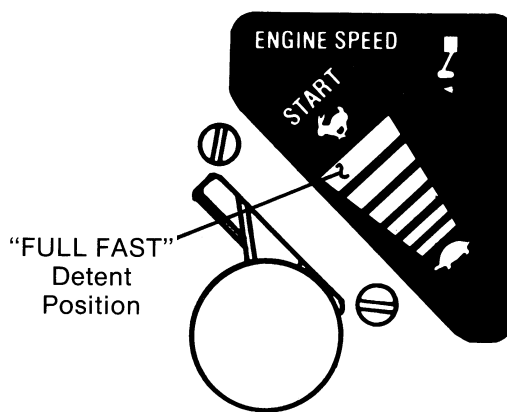

FIG. 8

NOTE: Also check mower drive belt adjustment per procedures under "BELTS".

Add gas and oil (if new engine) as prescribed by engine manufacturer. Start and test engine to insure that when throttle control lever is in the detent position, engine is running at its "FULL FAST" throttle speed. If it isn't, readjust throttle cable until "FULL FAST" throttle speed is reached.

## MOWER DECK:

### 1. Mower Deck Removal and Replacement —

**WARNING:** To avoid accidental starting, remove spark plug wire and secure away from spark plug.

- A. Remove center console tray.
- B. Pull the mower drive lever to the disengaged position. (Fig. 9)

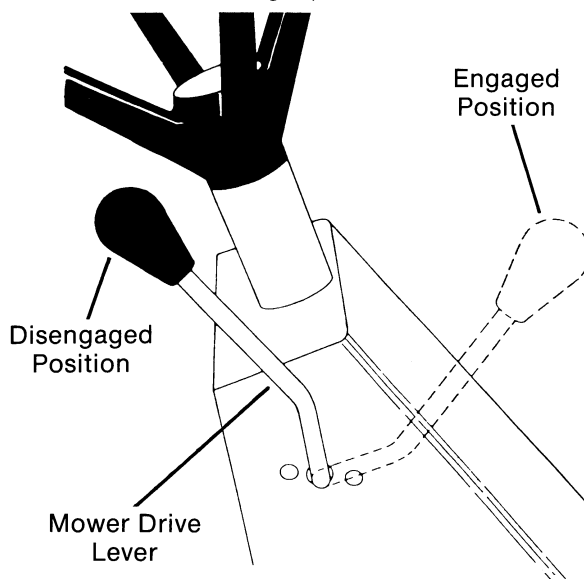

FIG. 9

- C. Remove cotter pin and clevis pin securing blade engagement link to mower drive crank. (Fig. 10)

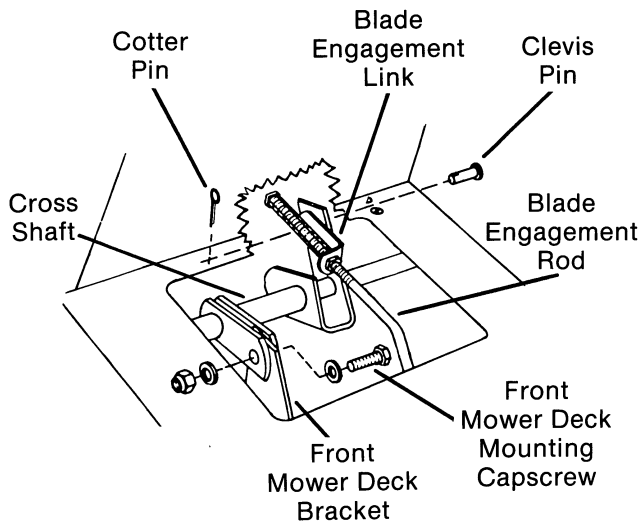

FIG. 10

- D. Remove capscrew, washers and locknut securing cross shaft assembly to front mower deck bracket. (Fig. 10)
- E. Remove capscrews, washers, bushings and locknuts securing left and right rear mower deck brackets to rear lift assembly. (Fig. 11)

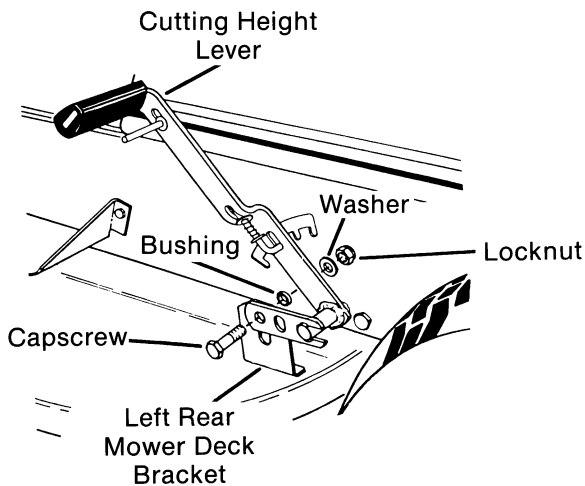

FIG. 11

- F. Loosen, but do not remove, two locknuts securing engine pulley belt guide to main frame. (Fig. 5)
- G. Slide engine pulley belt guide to the rear. Reach under rear of main frame and remove drive belt from engine pulley.
- H. Lift blade engagement rod and rotate rod to the left to clear the cross shaft. (Fig. 10)
- I. Lift front of rider up and push rider backwards over mower deck.

**IMPORTANT** — When remounting mower deck, belt should be routed above rear lift cross brace and differential when attaching belt to engine pulley.

- J. To remount mower deck, reverse above procedure. Refer to “MOWER DRIVE BELT ADJUSTMENT” to set proper adjustment of mower drive belt.

**NOTE:** During remounting of mower deck, be sure blade engagement rod is positioned above the cross shaft. (Fig. 10)

## 2. Blade Removal and Replacement —

**WARNING:** To avoid accidental starting, remove spark plug wire and secure away from spark plug.

- A. Set parking brake and drain gas from fuel tank if tank is more than half full.
- B. Turn ignition key “OFF”. Remove battery rod from retainer battery and slide battery forward.

**WARNING:** To avoid burns, be careful not to short the positive (+) terminal of battery to the rider when removing from mounting.

- C. Disconnect both battery cables from battery. Disconnect negative (-) terminal **first**. Remove battery from rider.

**WARNING:** To avoid personal injury when raising or lowering the rear engine rider, make sure you are capable of handling the weight. When in doubt get assistance.

- D. Raise front of rider up and stand on rear support bars. (Fig. 6)
- E. Remove center locknut from spindle shaft. (Fig. 12)

**NOTE:** It may be necessary to block blade with a piece of wood to prevent blade rotation while loosening or tightening blade.

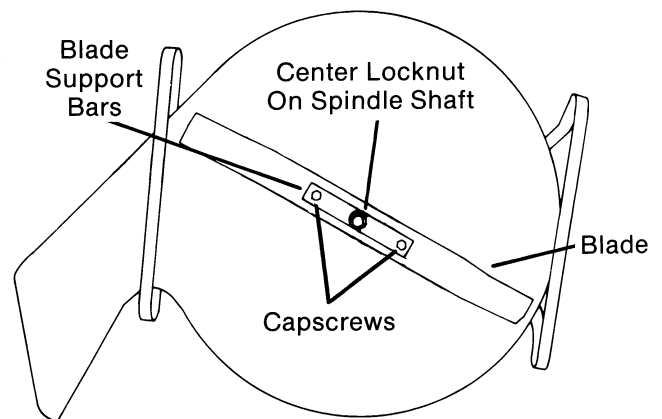

FIG. 12

- F. Loosen, but do not remove, two capscrews holding blade support bars. (Fig. 12) Remove blade and blade support bars from spindle shaft.
- G. To replace blade after balancing or sharpening, follow procedures below.
- H. Put blade and blade support bars back on spindle shaft.
- I. Replace center locknut and tighten to a torque of 50 ft./lbs.
- J. Tighten two blade support bar capscrews to a torque of 60 ft./lbs.

**IMPORTANT:** The capscrews used to secure blade support bars to blade are Grade 5 type. Other types of capscrews should not be used as replacements.

- K. Finish tightening center locknut on spindle shaft to a torque of 100 ft./lbs.
- L. Lower rider back to the ground and refill fuel tank and test operation.

- C. After sharpening, check blade for balance by supporting blade as shown in (Fig. 14) using center hole as a guide. File or grind metal from heavy end of blade until blade balances.

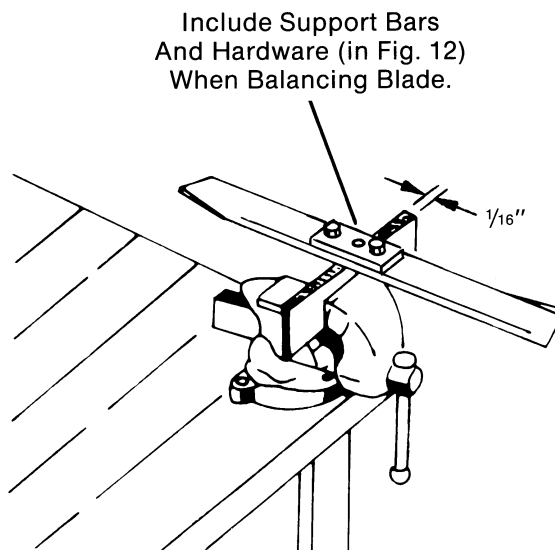

- D. Remount blade by following procedure above under "BLADE REMOVAL AND REPLACEMENT" starting with step "H".

### 3. Blade Sharpening and Balancing —

- A. Remove blade as described in procedure above.
- B. Sharpen beveled edges of the blade, reference (Fig. 13) for correct dimensions and instructions.

**NOTE:** If more than 1/2" is removed from width of blade, replace with new blade.

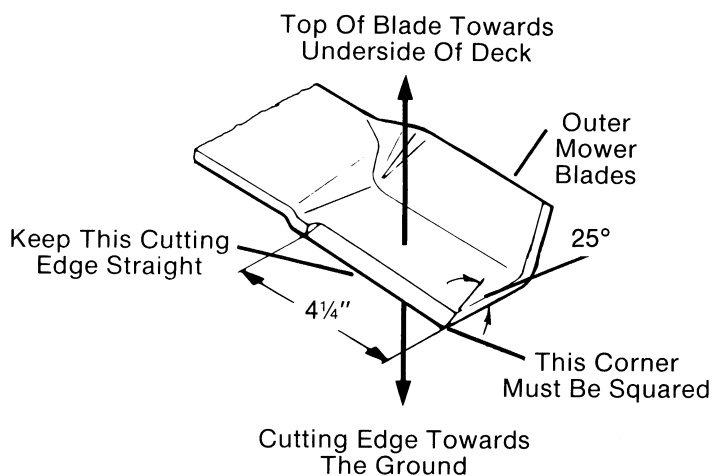
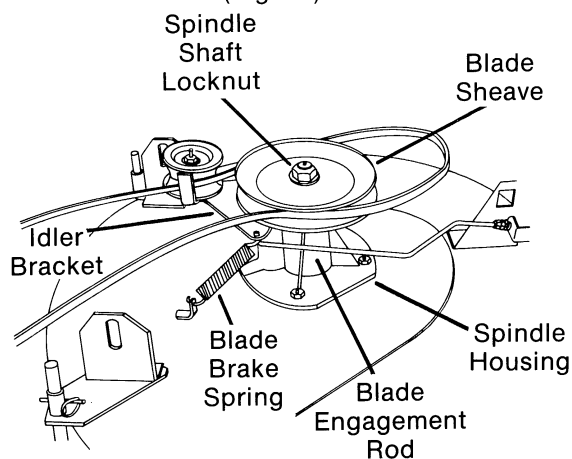

**FIG. 13**

### 4. Mower Spindle Removal and Replacement

**WARNING:** To avoid accidental starting, remove spark plug wire and secure away from spark plug.

- A. Remove mower deck by following procedures in Step 1, "MOWER DECK REMOVAL AND REPLACEMENT".
- B. Detach blade brake spring from blade engagement rod at idler bracket. Remove spring from mower deck. (Fig. 15)



**FIG. 15**

- C. Remove mower drive belt from around blade sheave.
- D. Stand mower deck up on mower deck gauge wheels and brace or block deck in upright position.
- E. Remove bottom center locknut securing blade to spindle shaft. (Fig. 12)

NOTE: It may be necessary to block blade with a piece of wood to prevent blade rotation while loosening or tightening blade.

- F. Loosen, do not remove, two capscrews holding blade support bars to blade. (Fig. 12)
- G. Remove blade with blade support bars, spinner cap and spacer from bottom of spindle shaft.
- H. Holding bottom end of spindle shaft, remove top spindle shaft locknut holding blade sheave to spindle shaft. (Fig. 15)

NOTE: When reassembling blade sheave to spindle shaft. Torque top spindle shaft locknut to 100 ft./lbs.

- I. Remove blade sheave and spacer from spindle shaft. (Fig. 15)
- J. Spindle shaft and upper and lower bearings can now be removed from mower spindle housing.
- K. At this time, all parts of mower spindle assembly can be checked for damage or excessive wear. Check following parts and replace if necessary. (Fig. 16)

- a. upper and lower bearings for wear.
- b. spindle shaft for sharp edges, gouges or stripped threads.
- c. spindle housing for cracks.
- d. blade sheave-check belt surfaces for residue, chips or nicks.
- e. blade sheave brake pad on idler bracket for excessive wear.
- f. idler pulley for excessive wear or radial play.

- L. Reassemble mower deck spindle assembly by reversing above procedure and follow the special torque procedures below for tightening the blade.

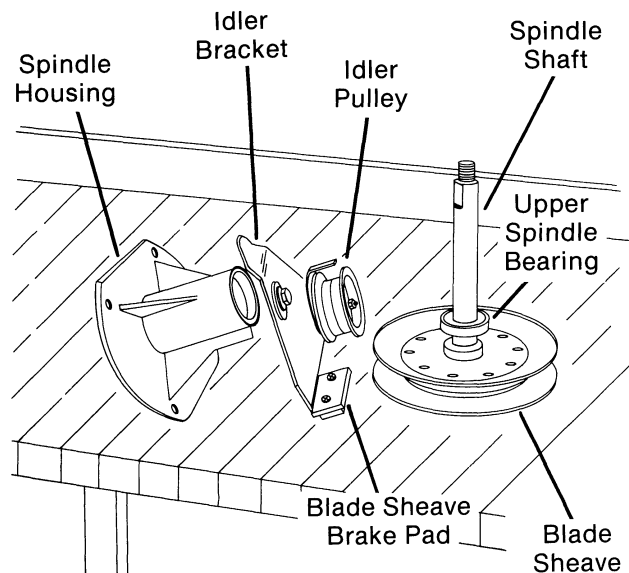

FIG. 16

- M. Replace lower center locknut and tighten to a torque of 50 ft./lbs.
- N. Tighten two blade support bar capscrews to a torque of 60 ft./lbs.

IMPORTANT: The capscrews used to secure blade support bars to blade are Grade 5 type. Other types of capscrews should not be used as replacements.

- O. Finish tightening lower center locknut on spindle shaft to a torque of 100 ft./lbs.
- P. Reassemble mower deck to rider by reversing procedures in Step 1, "MOWER DECK REMOVAL AND REPLACEMENT".

#### 5. Mower Drive Brake Adjustment —

This adjustment is pre-set at the factory and should not normally need readjustment. If mower blade does not stop within the required 7 second safe stopping time, check brake pad for wear or readjust jam nuts on blade engagement rod, as follows:

- A. Remove center console tray.
- B. Turn ignition switch "OFF".
- C. Push mower drive lever to the engaged position. (Fig. 9)
- D. Loosen two jam nuts on blade engagement rod.



**Suggest:**

**If the above button click is invalid.**

**Please download this document**

**first, and then click the above link**

**to download the complete manual.**

**Thank you so much for reading**

- E. Turn jam nuts until the dimension shown in (Fig. 17) is achieved or until 7 second blade safe stopping time is met. (A test of the rider will have to be made with a stop watch with engine running at full speed and mower deck engaged to test stopping time).

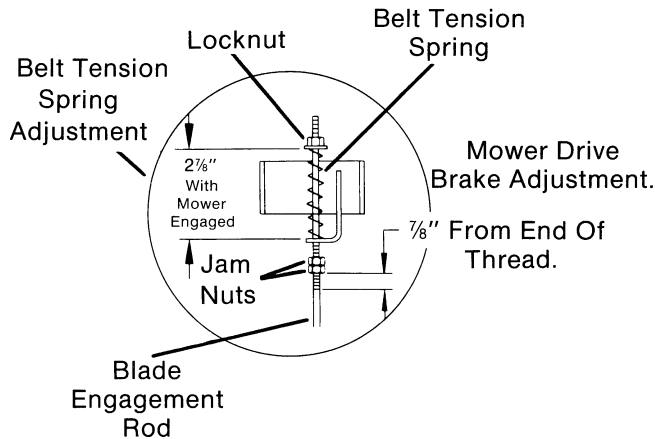

FIG. 17

- F. Retighten jam nuts against each other and test unit.

## BELTS:

These belts were designed and engineered to provide long, trouble-free service. If replacement is necessary, use **only** the belts recommended by manufacturer to be sure you have a belt that will provide the life and service required.

### 1. Mower Drive Belt Adjustment —

If belt has stretched and begins to slip under load, adjust belt as described below:

**WARNING:** To avoid accidental starting, disconnect spark plug wire and secure away from spark plug.

- Move mower drive lever to the engaged position. (Fig. 9)
- Looking through the slot, at the rear of main frame between support bars, towards front of rider. Check minimum clearance between the two sides of mower drive belt. (Fig. 18)

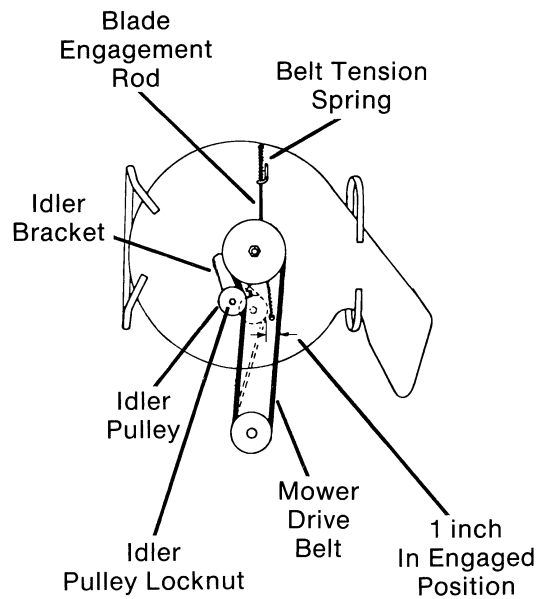

FIG. 18

- If clearance between belt sides is less than 1 inch, adjust belt as follows:
  - Pull mower drive lever back to the disengaged position.
  - Loosen two nuts on each of the three mower deck brackets. (Fig. 19)

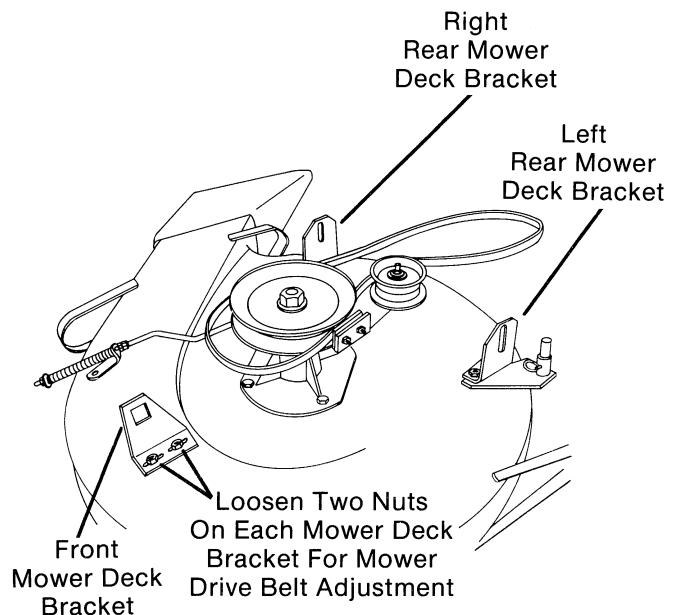

FIG. 19

**<https://www.ebooklibonline.com>**

Hello dear friend!

Thank you very much for reading.

Enter the link into your browser.

The full manual is available for immediate download.

**<https://www.ebooklibonline.com>**