

Yard Tractors

LS 25

LS 35

LS 45

LS 55

Includes supplement

SERVICE MANUAL

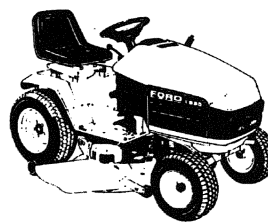

NEW HOLLAND

CONTENTS

| | |
|--|------------|
| FORWARD | 0-2 |
| SECTION 2 – ELECTRICAL SYSTEM | 2-1 |
| SECTION 3 – PTO CLUTCH | 3-1 |
| SECTION 4 – TRANSAXLE BRAKES | 4-1 |
| SECTION 6 – STEERING | 6-1 |
| SECTION 7 – ELECTROHYDRAULIC LIFT | 7-1 |
| SECTION 8 – SPECIFICATIONS | 8-1 |
| SECTION 9 – MOWER DECKS | 9-1 |

FOREWORD

Only components that are unique to the 1996 LS series tractors and mower decks are contained in this supplement. For all other components of the tractor, refer to the appropriate sections of LS Service Manual 40002550.

The material contained in this supplement was correct at the time of going to print, but New Holland North America, Inc. policy is one of continuous improvement, and the right to change prices, specifications, equipment or design at any time without notice is reserved. All data in this manual is subject to production variations. Overall dimensions and weights should be considered as approximate only, and the illustrations do not necessarily depict the unit to standard built specification.

NEW HOLLAND NORTH AMERICA, INC.

<https://www.ebooklibonline.com>

Hello dear friend!

Thank you very much for reading.

Enter the link into your browser.

The full manual is available for immediate download.

<https://www.ebooklibonline.com>

SECTION 4

TRANSAXLE BRAKES

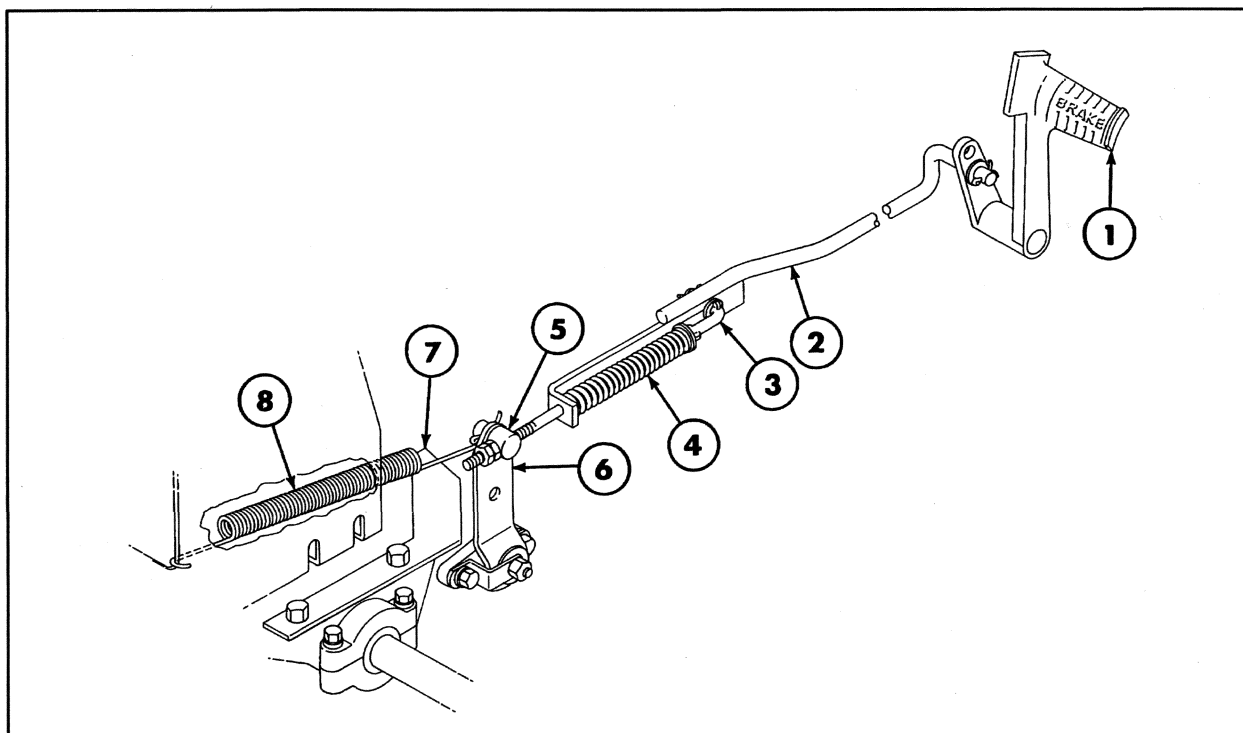

Figure 4-1

This section describes changes made to the transaxle brakes of LS series tractors with T6 serial numbers.

BRAKE LINKAGE COMPONENTS

The brake linkage is made up of the following components:

- Pedal, 1
- Arm, 2
- Rod, 3
- Compression Spring, 4
- Trunnion, 5
- Brake Lever Arm, 6
- Stop Plate, 7
- Return Spring, 8

BRAKE OPERATION

When the brake pedal is applied, the arm on the pedal, 1, rotates forward. This causes the brake arm, 2, to move forward until the end of the slotted hole contacts the brake rod, 3. Together, the arm and the rod pull the lever arm, 6, forward and the brake pads contact the brake disc, stopping the rear axle. If the pedal is applied further, the compression spring, 4, becomes compressed, preventing the linkage from being over traveled. When the pedal is released, the return spring, 8, moves the linkage back to the "REST" position.

ADJUSTING THE BRAKE LINKAGE**Step 1**

With the brake pedal in the "REST" position, loosen the two jam nuts, 1, on the brake rod, 2.

Remove the cotter pin and flat washer from the trunnion, 3, connected to the brake lever arm. Adjust the trunnion on the threaded brake rod, 4, so that the brake lever arm, 5, just contacts the brake stop plate, 6.

Reinstall the washer and cotter pin and tighten the two jam nuts.

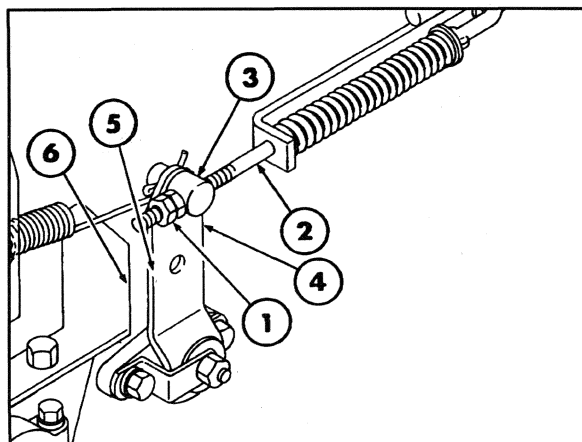

Figure 4-2

Step 2

Adjust the brake pad to disc clearance by adjusting the nut, 1, on the end of the caliper assembly. Adjust the nut until there is a .005" (0.13 mm) clearance between the outer pad and disc.

Replace the brake pads when the nut can no longer be adjusted.

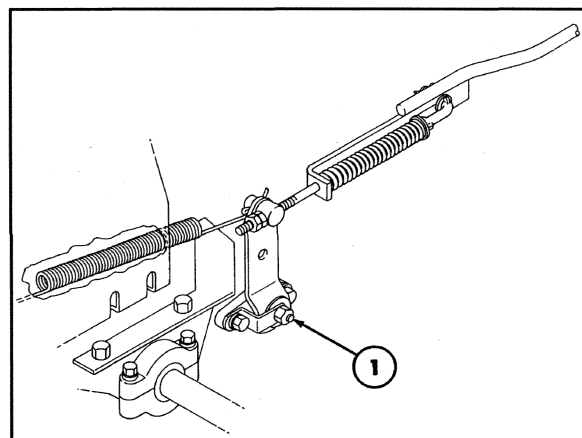

Figure 4-3

SECTION 6

STEERING

For all LS series tractors having a T6 serial number or later, the steering wheel is secured to the upper steering shaft with a nut and lock washer instead of a roll pin as in previous production. The upper steering shaft is splined and threaded.

NOTE: The steering wheel retaining nut should be tightened using a torque of 50 ft. lbs. (37 N·m).

The steering components for all LS series tractors having a T6 serial number or later are:

1. Shaft
2. Spring
3. Spacer
4. Steering wheel
5. Lock washer, 1/2"
6. Nut, 1/2" NC
7. Cover plate and emblem

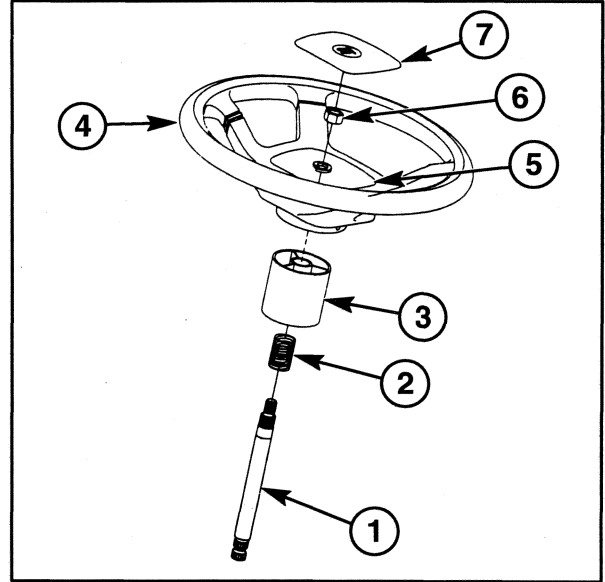

Figure 6-1

SECTION 7

ELECTROHYDRAULIC LIFT

The electrohydraulic lift system is standard equipment on all LS 55 tractors with a T6E serial number or later. It is also available as a field installed option, Kit 9863223 wholegoods, on any other LS series tractor.

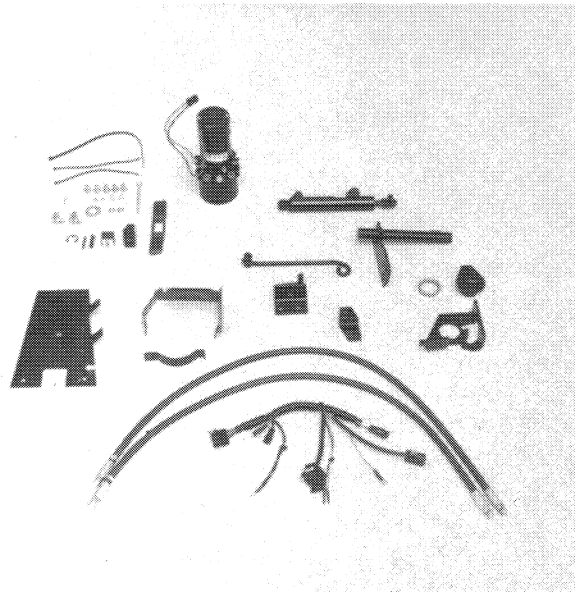

Figure 7-1

COMPONENTS

The electrohydraulic lift system consists of the following components:

Control Switch and Wire Harness, 1

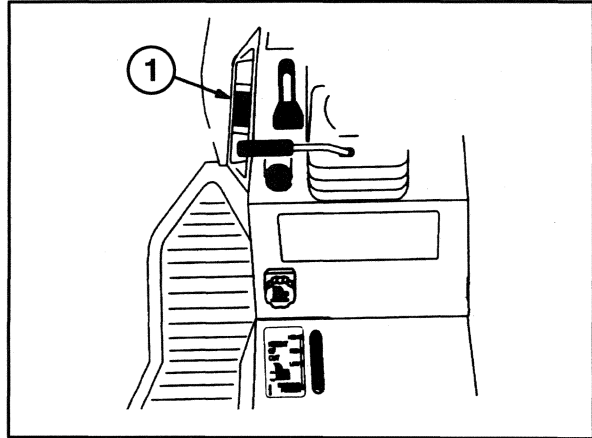

Figure 7-2

Reservoir/Pump Assembly

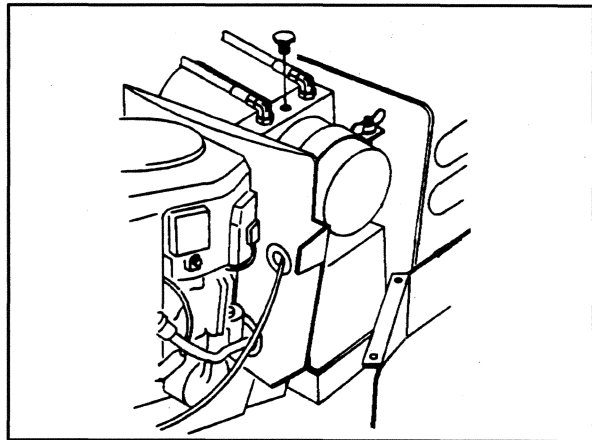

Figure 7-3

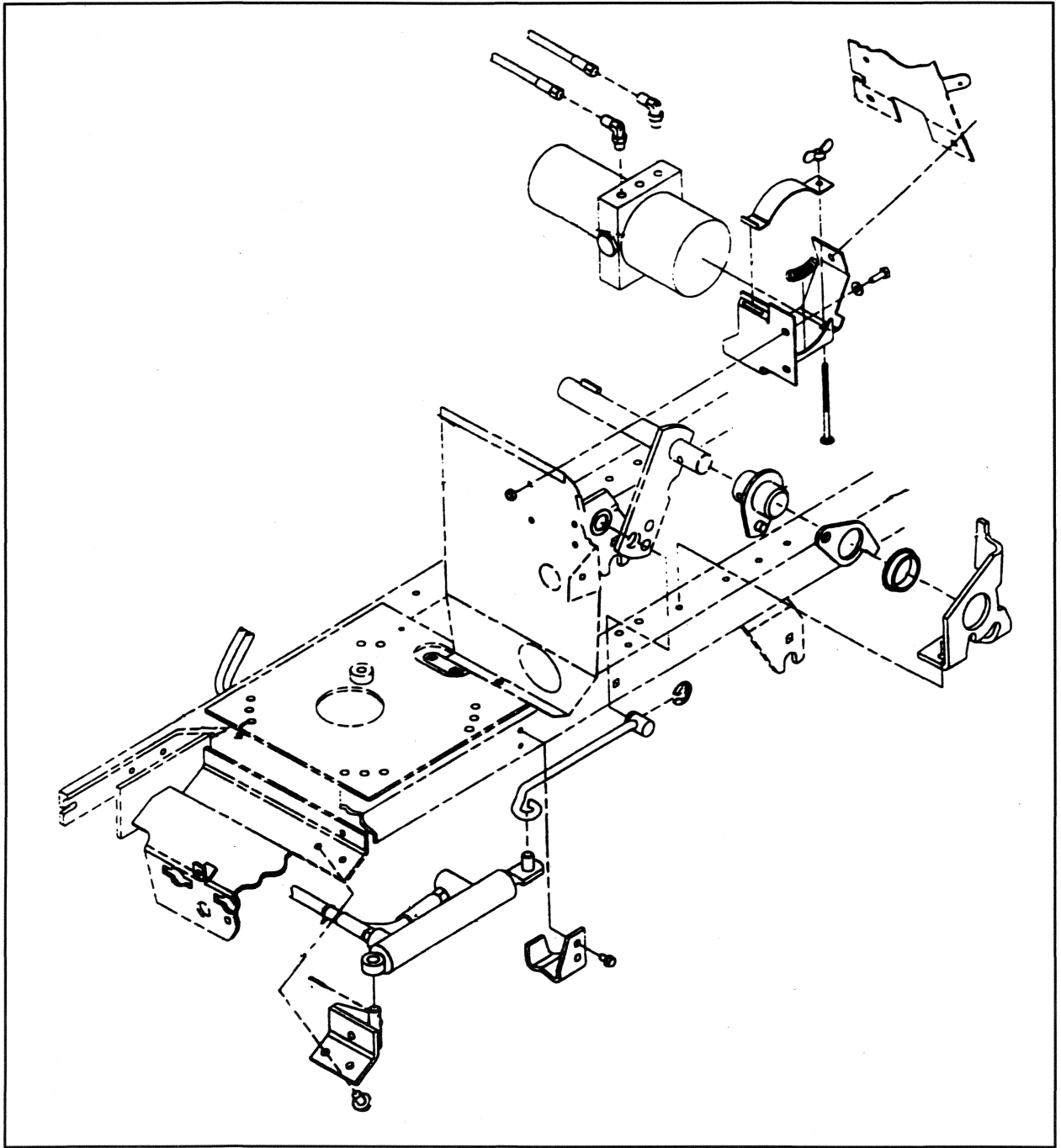

Figure 7-4

Cylinder, Hoses, and Linkage

OPERATION

When the top half of the control switch is depressed, the pump is activated, sending oil from the pump to the base end of the cylinder. This retracts the cylinder and raises the lift linkage.

When the bottom half of the control switch is depressed, the pump is activated, sending oil from the pump to the rod end of the cylinder. This extends the cylinder and lowers the lift linkage.

NOTE: The Dial-A-Height linkage controls the distance by which the deck is lowered.

RESERVOIR/PUMP ASSEMBLY LOCATION

The reservoir/pump assembly is mounted horizontally behind the engine compartment and above the battery.

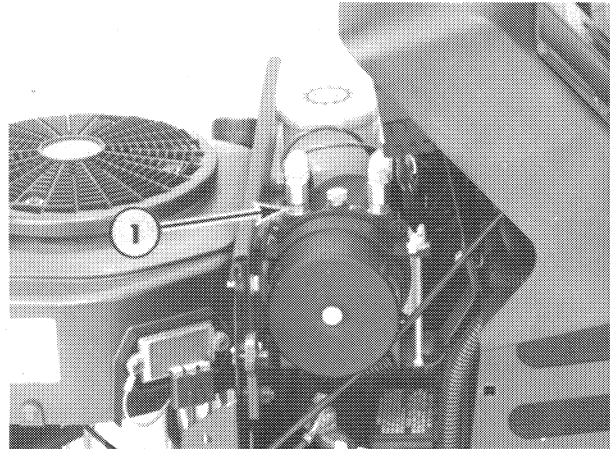

Figure 7-5

PUMP ASSEMBLY COMPONENTS
108 SERIES POWER UNIT COMPONENTS

| Item Number | Description | Quantity |
|-------------|------------------------------------|----------|
| 1 | Motor Mounting Stud | 2 |
| 2 | Motor | 1 |
| 3 | Coupling | 1 |
| 4 | O ring | 1 |
| 5 | Adapter | 1 |
| 6 | 1/4" Steel Ball | 3 |
| 7 | Spool | 1 |
| 8 | Check Valve Body | 2 |
| 9 | Poppet Assembly | 2 |
| 10 | Spring | 2 |
| 11 | Hex Plug | 2 |
| 12 | 3/16" Ball | 2 |
| 13 | Eyelet | 4 |
| 14 | Spring | 4 |
| 15 | Thermal Relief | 2 |
| 16 | Shaft Seal </td <td>1</td> | 1 |
| 17 | O ring | 2 |
| 18 | Pump | 1 |
| 19 | #10-32 UNF 1 5/16" Torx Head Screw | 2 |
| 20 | Filter | 2 |
| 21 | Reservoir Seal | 1 |
| 22 | Reservoir | 1 |
| 23 | #10-32 X 1" Hex Head Screw | 1 |
| 24 | O ring | 1 |
| 25 | 3/16" Steel Ball | 1 |
| 26 | 7/16"-20 Jam Nut | 2 |
| 27 | Relief Valve Adjust Screw | 2 |

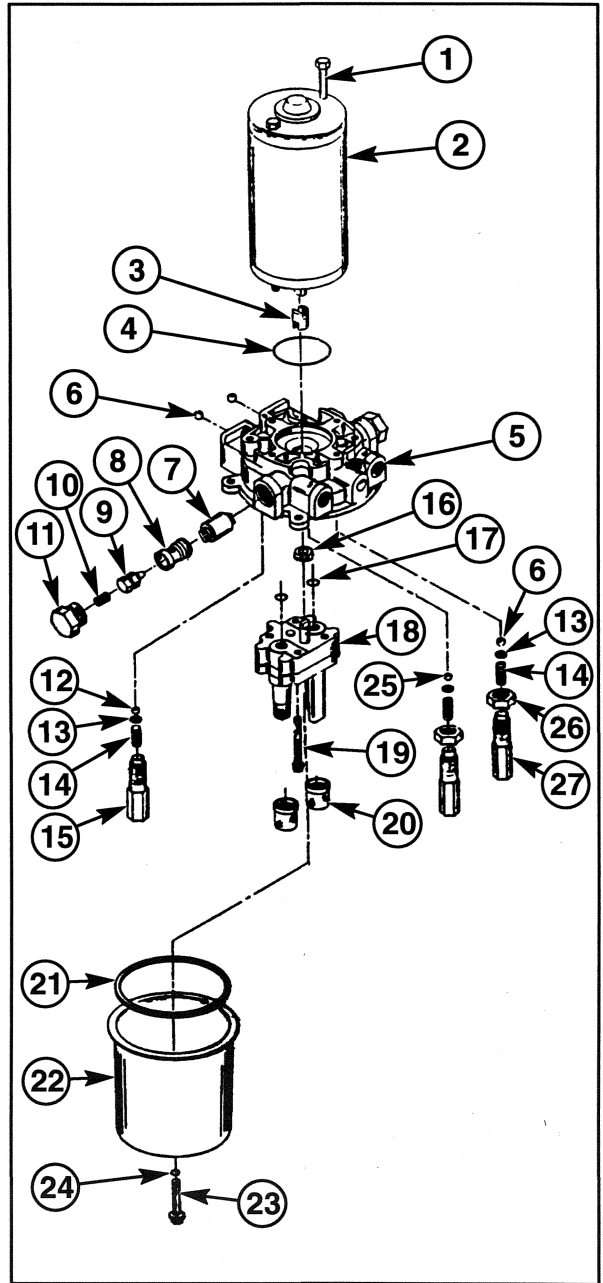

Figure 7-6

RESERVOIR DESCRIPTION

The reservoir, 1, is located on the left side of the pump assembly. A breather fitting, 2, located in the center of the pump section housing, allows air to enter and escape the reservoir. It is also used for the reservoir fill port.

Reservoir capacity is 12.5 oz. Dextron II hydraulic fluid should always be used to fill the reservoir.

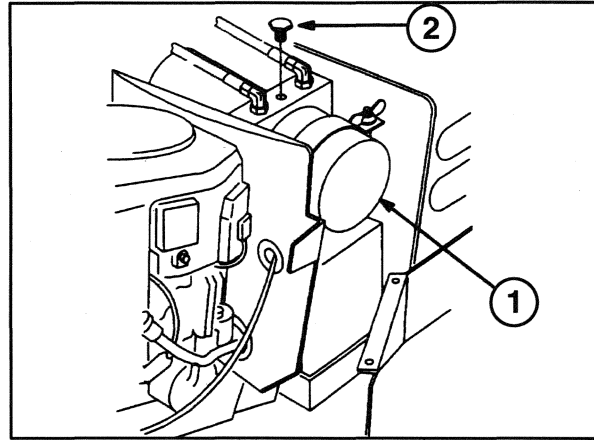

Figure 7-7

PUMP/VALVE DESCRIPTION

The pump is a gear type. It is driven in either a clockwise or counterclockwise rotation by an electric motor. Pump output is rated at 0.23 gallons per minute at 500 psi (34 bar).

Two pressure relief valves protect the pump from overload. The "UP" mode is rated at 1000 psi (68 bar). The "DOWN" mode is rated at 400 psi (27.2 bar).

Two thermal relief valves are set approximately 500 psi (34 bar) higher than the circuit relief valves. The thermal relief valves act as safety valves, compensating for higher pressures due to increases in temperature.

NOTE: Thermal relief valves are not adjustable.

PUMP/VALVE COMPONENTS

The pump/valve consists of the following components:

- "UP" Relief Valve, 1
- "DOWN" Relief Valve, 2
- "UP" Thermal Relief Valve, 3
- "DOWN" Thermal Relief Valve, 4
- Pump, 5
- Filter Screens, 6

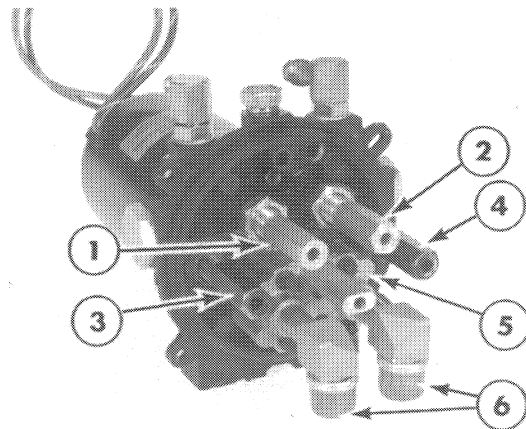

Figure 7-8

ADAPTER BLOCK COMPONENTS (AS VIEWED FROM MOTOR END)

The following components are enclosed in the adapter housing:

- Hex Cap, 1
- Spring, 2
- Check Valve Body, 3
- Check Valve & Poppet, 4
- Spool, 5
- High Pressure Port (Raise), 6
- Low Pressure Port (Lower), 7

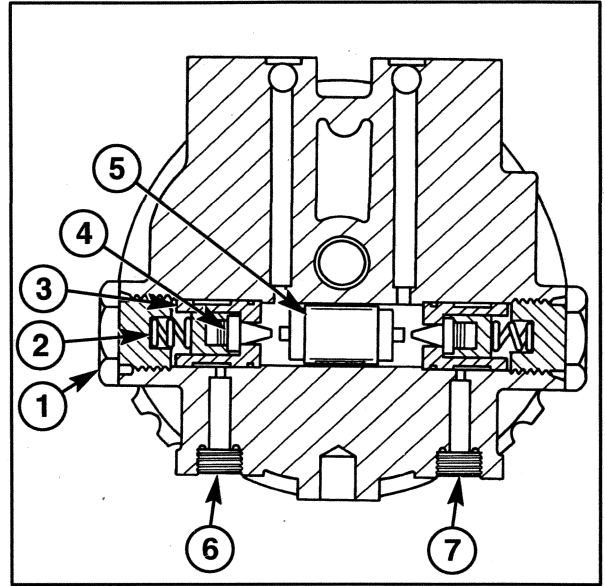

Figure 7-9

OIL FLOW AND CHECK VALVE OPERATION (as viewed from motor end)

Pump in Neutral Mode

In neutral, the unit is at rest with static oil in both ports. The check valves are seated against the check valve bodies. Because the pump is not rotating, there is no oil flow.

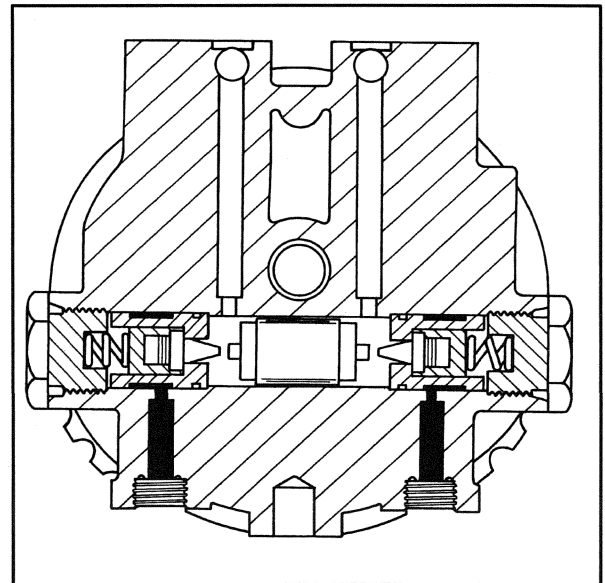

Figure 7-10

Pump in Raise Mode

With the lift switch held in the “RAISE” position, the lift cylinder retracts as the pump rotates. Hydraulic pressure shifts the spool to the right, unseating the low pressure check valve. This allows oil to return from the rod end of the cylinder to the pump reservoir.

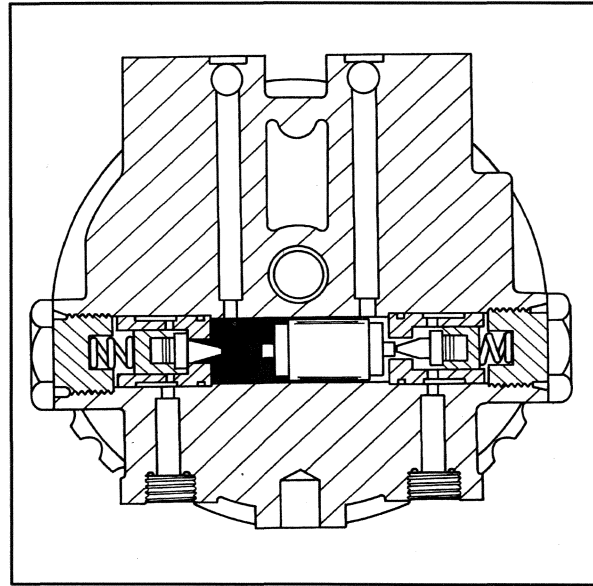

Figure 7-11

Hydraulic pressure unseats the high pressure check valve, allowing oil to flow through the high pressure port to the cylinder.

When the lift switch is released, the pump stops rotating, the spool moves back to its centered position, and both check valves are resealed.

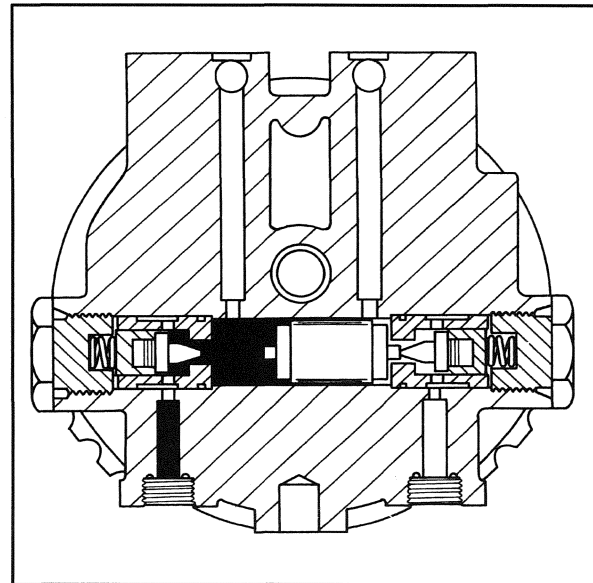

Figure 7-12

Pump in Lower Mode

With the lift switch held in the “LOWER” position, the lift cylinder is extended as the pump rotates. Hydraulic pressure shifts the spool to the left, unseating the high pressure check valve. This allows oil to be sent from the piston end of the cylinder to the pump reservoir.

When the low pressure check valve becomes unseated, oil flows through the low pressure port from the pump to the cylinder.

When the lift switch is released, the pump stops rotating, the spool moves back to its centered position, and both check valves are resealed.

RELIEF VALVE TESTING (pump as viewed from reservoir end)

Up Mode

Remove the hose on the left side of the pump housing and install a 2000 psi (136 bar) gauge to the pump fitting.

NOTE: Fitting size is 7/16 20 37° flare.

Turn the key switch to the "RUN" position.

Place the lift switch in the "UP" position until the maximum pressure reading is obtained.

Record the pressure gauge reading.

Pressure reading should be 1000 psi (68 bar) \pm 100 psi (6.8 bar).

Relief Valve Removal/Adjustment Procedure

If the pressure reading is not within specified limits, remove the relief valve located inside the reservoir.

NOTE: Count and record the number of turns the valve body rotates as it is removed from the housing.

Inspect the relief valve ball and seat for any damage. Clean parts with solvent and then reassemble.

Replace the relief valve body into the housing using the same number of turns that were counted during removal.

Adjust the relief valve by loosening the jam nut and rotating the valve body clockwise to increase pressure or counterclockwise to decrease pressure. Tighten the jam nut after adjustment is completed.

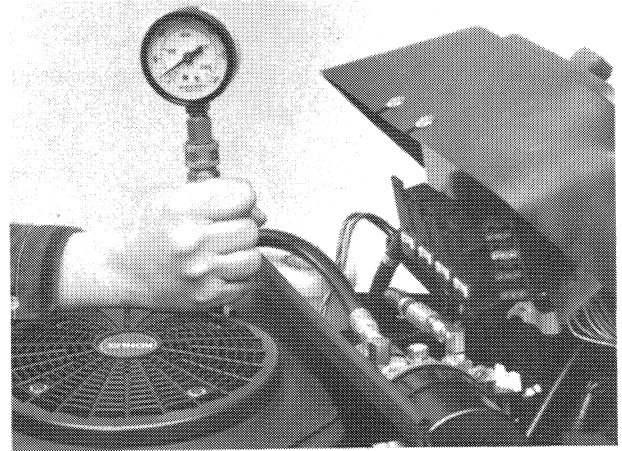

Figure 7-13



Suggest:

If the above button click is invalid.

Please download this document

first, and then click the above link

to download the complete manual.

Thank you so much for reading

Down Mode

Remove the hose on the right side of the pump housing and install a 1000 psi (68 bar) gauge to pump fitting.

NOTE: Fitting size is 7/16 20 37° flare.

Turn the key switch to the "RUN" position.

Place the lift switch in the "DOWN" position until the maximum pressure reading is obtained.

Record the pressure gauge reading.

Pressure reading should be 400 psi (27.2 bar) \pm 100 psi (6.8 bar).

Relief Valve Removal/Adjustment Procedure

Follow the same removal/adjustment procedure as outlined in the previous section on Relief Valve Testing in the Up Mode.

PUMP FLOW TESTING (pump as viewed from reservoir end)

Note: Ambient temperature should be at least 70°F (39°C) when conducting this test.

Remove one of the hoses connected to the pump outlet fittings and place the end of the hose into a container.

Turn the key switch to the "RUN" position.

Place the lift switch in the "UP" position if the hose from the left side of the pump was removed (as is shown in the figure). Place the lift switch in the "DOWN" position if the hose was removed from the right side of the pump.

Activate the pump for 10 SECONDS ONLY.

IMPORTANT: Do not operate the pump for more than 10 seconds while the hose is removed. Longer operating times may pump the reservoir dry and result in pump damage. Always remember to refill the reservoir after testing.

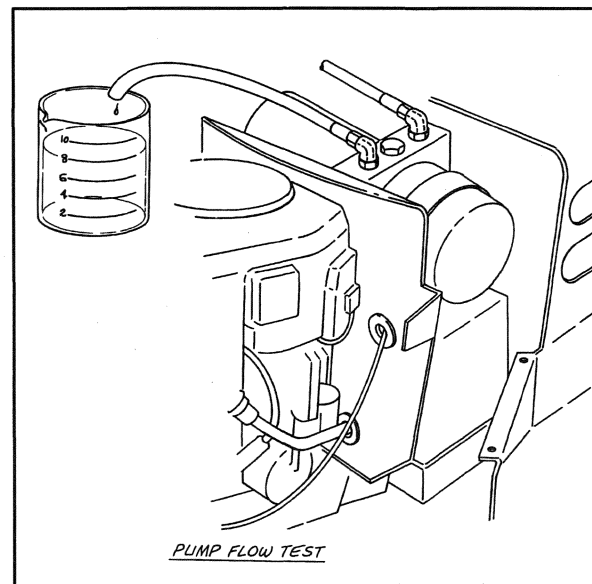

Figure 7-14

<https://www.ebooklibonline.com>

Hello dear friend!

Thank you very much for reading.

Enter the link into your browser.

The full manual is available for immediate download.

<https://www.ebooklibonline.com>