

NEW HOLLAND

Service Manual

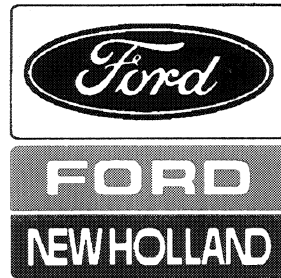

Skid-Steer Loaders
L-781, L-784, L-785

40078130



Reprinted

INTRODUCTION

This manual provides the technical information needed to properly service and maintain the L-780 series skid-steer loaders. Use this manual in conjunction with the operator's manual which is supplied with the loader. Keep both manuals available for ready reference.

On New Holland equipment, left and right are determined by standing behind the unit, looking in the direction of travel.

For information on engine repair, refer to the manufacturer's service manual.

The easiest and least time-consuming removal, disassembly, and reassembly procedures are detailed in this manual. Modifying these procedures is not recommended.

The L-780 series skid-steer loaders have been designed with emphasis on safety for operator protection. However, careless and negligent operation can still result in serious injury to persons or property. Be sure to read and follow all safety instructions in this manual.

Your New Holland dealer will be glad to answer any questions you may have about your loader. When major service is required, his staff of trained servicemen is ready to serve you.

When in need of parts, always order genuine New Holland service parts from your New Holland dealer. Be prepared to give your dealer the model and serial number of the engine and loader. Locate these numbers now and record them below.

Loader Model

Loader Serial Number

Engine Model

Engine Serial Number



CAUTION: THIS SYMBOL IS USED THROUGHOUT THIS BOOK WHENEVER PERSONAL SAFETY IS INVOLVED. TAKE TIME TO READ AND FOLLOW THE INSTRUCTIONS. BE CAREFUL!

IMPROVEMENTS

New Holland is continually striving to improve its products. We reserve the right to make improvements or changes when it becomes practical and possible to do so, without incurring any obligation to make changes or additions to the equipment sold previously.

ALL SPECIFICATIONS ARE SUBJECT TO CHANGE WITHOUT NOTICE.

CONTENTS

SAFETY	0-2
SECTION 1 - OPERATION	1-1
SECTION 2 - STEERING ADJUSTMENTS	2-1
SECTION 3 - HYDROSTATIC TRANSMISSION REMOVAL	3-1
SECTION 4 - TRANSMISSION PUMP REPAIR	4-1
SECTION 5 - HYDROSTATIC TRANSMISSION MOTORS	5-1
SECTION 6 - GEAR PUMP	6-1
SECTION 7 - BUCKET AND BOOM CYLINDERS	7-1
SECTION 8 - CONTROL VALVE	8-1
SECTION 9 - FINAL DRIVE	9-1
SECTION 10 - ELECTRICAL SYSTEM	10-1
SECTION 11 - SEAT ACTIVATED BOOM LOCKOUT	11-1
SECTION 12 - TROUBLESHOOTING	12-1
SECTION 13 - SPECIFICATIONS	13-1
INDEX	13-16



<https://www.ebooklibonline.com>

Hello dear friend!

Thank you very much for reading.

Enter the link into your browser.

The full manual is available for immediate download.

<https://www.ebooklibonline.com>



PLEASE READ CAREFULLY!

INCLUDED THROUGHOUT THIS MANUAL AND ON MACHINE DECALS YOU WILL FIND PRECAUTIONARY STATEMENTS SUCH AS “CAUTION”, “WARNING” AND “DANGER”, FOLLOWED BY SPECIFIC INSTRUCTIONS.

THESE PRECAUTIONS ARE INTENDED FOR THE PERSONAL SAFETY OF YOU AND THOSE WORKING WITH YOU. PLEASE TAKE THE TIME TO READ THEM.

PERSONAL SAFETY!

CAUTION: THE WORD “CAUTION” IS USED WHERE A SAFE BEHAVIORAL PRACTICE ACCORDING TO OPERATING AND MAINTENANCE INSTRUCTIONS AND COMMON SAFETY PRACTICES WILL PROTECT THE OPERATOR AND OTHERS FROM ACCIDENT INVOLVEMENT.

WARNING: THE WORD “WARNING” DENOTES A POTENTIAL OR HIDDEN HAZARD WHICH HAS A POTENTIAL FOR SERIOUS INJURY. IT IS USED TO WARN OPERATORS AND OTHERS TO EXERCISE EVERY APPROPRIATE MEANS TO AVOID A SURPRISE INVOLVEMENT WITH MACHINERY.

DANGER: THE WORD “DANGER” DENOTES A FORBIDDEN PRACTICE IN CONNECTION WITH A SERIOUS HAZARD.

ADDITIONAL PRECAUTIONARY STATEMENTS SUCH AS “ATTENTION” AND “IMPORTANT” ARE FOLLOWED BY SPECIFIC INSTRUCTIONS. THESE STATEMENTS ARE INTENDED FOR MACHINE SAFETY.

MACHINE SAFETY!

ATTENTION: THE WORD “ATTENTION” IS USED TO WARN THE OPERATOR OF POTENTIAL MACHINE DAMAGE IF A CERTAIN PROCEDURE IS NOT FOLLOWED.

IMPORTANT: THE WORD “IMPORTANT” IS USED TO INFORM THE READER OF SOMETHING HE NEEDS TO KNOW TO PREVENT MINOR MACHINE DAMAGE IF A CERTAIN PROCEDURE IS NOT FOLLOWED.

IMPORTANT!

FAILURE TO FOLLOW THE “CAUTION”, “WARNING”, AND “DANGER” INSTRUCTIONS MAY POSSIBLY RESULT IN SERIOUS BODILY INJURY OR DEATH.



SAFETY INFORMATION

UNSAFE OPERATING PRACTICES AND IMPROPER USE OF THE LOADER AND ITS ATTACHMENTS ON THE PART OF THE OPERATOR CAN RESULT IN INJURIES. OBSERVE THE FOLLOWING SAFETY PRECAUTIONS AT ALL TIMES.

- 1. GIVE UNDIVIDED ATTENTION TO THE JOB AT HAND SO COMPLETE CONTROL OF THE LOADER IS MAINTAINED AT ALL TIMES.**
- 2. DRIVE SLOWLY OVER ROUGH GROUND AND ON SLOPES. KEEP ALERT FOR HOLES, DITCHES, AND OTHER IRREGULARITIES THAT MAY CAUSE THE LOADER TO OVERTURN.**
- 3. AVOID STEEP HILLSIDE OPERATION WHICH COULD CAUSE THE LOADER TO OVERTURN.**
- 4. REDUCE SPEED WHEN TURNING SO THERE IS NO DANGER OF THE LOADER OVERTURNING.**
- 5. CARRY THE BUCKET AS LOW AS POSSIBLE AT ALL TIMES TO REDUCE THE POSSIBILITY OF THE LOADER OVERTURNING.**
- 6. ALWAYS LOOK BEHIND YOU BEFORE BACKING THE LOADER.**
- 7. MAINTAIN PROPER TRANSMISSION OIL LEVEL TO PREVENT LOSS OF BRAKING CONTROL.**
- 8. DO NOT ALLOW CHILDREN TO OPERATE THE LOADER OR RIDE ON THE LOADER AT ANY TIME.**
- 9. DO NOT ALLOW ANYONE TO OPERATE THE LOADER WITHOUT PROPER INSTRUCTION. THIS MACHINE CAN BE DANGEROUS.**
OSHA REQUIRES THAT ALL OPERATORS BE INSTRUCTED ON THE PROPER OPERATION OF THE MACHINE BEFORE THEY OPERATE THE UNIT.
- 10. DO NOT ALLOW PASSENGERS TO RIDE ON THE LOADER AT ANY TIME. THEY COULD BE INJURED OR KILLED.**
- 11. DO NOT OPERATE THE LOADER FROM ANY POSITION OTHER THAN THE OPERATOR'S SEAT WITH THE SEAT BELT SECURELY FASTENED, OR YOU COULD BE RUN OVER OR CRUSHED.**
- 12. BEFORE STARTING THE ENGINE, BE SURE ALL OPERATING CONTROLS ARE IN NEUTRAL.**
- 13. NEVER OPERATE THE LOADER ENGINE IN A CLOSED BUILDING WITHOUT ADEQUATE VENTILATION. ENGINE FUMES COULD INJURE OR KILL YOU.**
- 14. REFUEL THE LOADER OUTDOORS WITH THE ENGINE SHUT OFF. REPLACE THE FUEL CAP SECURELY. USE AN APPROVED FUEL CONTAINER. DO NOT SMOKE WHEN HANDLING FUEL. AVOID SPILLING FUEL.**
- 15. AFTER OPERATING THE ENGINE, NEVER TOUCH THE MUFFLER, EXHAUST PIPE, OR ENGINE UNTIL THEY HAVE HAD TIME TO COOL.**
- 16. DRESS APPROPRIATELY. WEAR RELATIVELY TIGHT-FITTING CLOTHING WHEN OPERATING THE LOADER. LOOSE OR TORN CLOTHING CAN CATCH IN MOVING PARTS OR THE CONTROLS.**
- 17. PULL LOADS ONLY FROM THE REAR HITCH YOKE.**
- 18. BEFORE SERVICING THE LOADER OR ANY OF ITS ATTACHED EQUIPMENT, BE SURE THE ATTACHMENTS ARE LOWERED TO THE GROUND OR THE BOOM ARMS ARE SUPPORTED BY THE BOOM LOCK PINS, THE UNIT IS SECURELY BLOCKED, AND THE ENGINE IS TURNED OFF. IF THE MACHINE WOULD MOVE OR THE BOOM DROP UNEXPECTEDLY, YOU COULD BE KILLED.**

19. DO NOT WORK UNDER OVERHANGS, ELECTRIC WIRES, OR WHERE THERE IS DANGER OF A SLIDE.
20. WEAR AN APPROVED SAFETY HAT WHEN OPERATING THE MACHINE AND WHILE IN ANY WORK AREA.
21. WEAR A SUITABLE HEARING PROTECTIVE DEVICE SUCH AS EAR MUFFS OR EAR PLUGS IF YOU ARE EXPOSED TO NOISE WHICH YOU FEEL IS UNCOMFORTABLE.
22. WHEN DRIVING THE LOADER ON A ROAD OR HIGHWAY, USE WARNING LIGHTS OR WARNING DEVICES AS MAY BE REQUIRED BY LOCAL OR STATE GOVERNMENTAL REGULATIONS. HEADLIGHTS AND WARNING LIGHT KITS ARE AVAILABLE THROUGH YOUR NEW HOLLAND DEALER. SLOW MOVING VEHICLE SIGNS ARE SUPPLIED AS STANDARD EQUIPMENT.
23. KEEP THE LOADER CLEAN. DO NOT ALLOW TRASH, DEBRIS, OR OTHER ARTICLES TO ACCUMULATE IN THE CAB OR FLOOR AREA THAT MAY HINDER SAFE MACHINE OPERATION.
24. NEVER OPERATE THE LOADER WITH ANY OF THE SHIELDING REMOVED. THE SHIELDS ARE THERE TO PROTECT YOU.
25. NEVER OPERATE THE LOADER WITHOUT THE WINDOWS AND/OR SCREENS IN PLACE.
26. READ ALL SAFETY MESSAGES ON THE LOADER.
27. OBSERVE ALL WEIGHT LOAD LIMITS ON DOCKS, BRIDGES, AND TEMPORARY BRIDGING.

OSHA REQUIREMENTS NOW MAKE IT THE EMPLOYER'S RESPONSIBILITY TO FULLY INSTRUCT EACH OPERATOR IN THE PROPER AND SAFE OPERATION OF ALL OPERATIVE EQUIPMENT. BOTH EMPLOYER AND EMPLOYEE SHOULD THOROUGHLY FAMILIARIZE THEMSELVES WITH THE FOLLOWING SECTIONS.



CAUTION!

PICTURES IN THIS MANUAL MAY SHOW PROTECTIVE SHIELDING OPEN OR REMOVED TO BETTER ILLUSTRATE A PARTICULAR FEATURE OR ADJUSTMENT.

BE CERTAIN, HOWEVER, TO CLOSE OR REPLACE ALL SHIELDING BEFORE OPERATING THE MACHINE.



DANGER!

**FASTEN SEAT BELT
BEFORE STARTING THE ENGINE!**

THIS LOADER IS A VERY STABLE UNIT, BUT IT CAN BE UPSET IF STOPPED SUDDENLY WHEN THE BUCKET IS RAISED AND LOADED. THEREFORE, DO NOT START THE ENGINE BEFORE SECURELY FASTENING THE SEAT BELT, AND CARRY THE LOAD LOW.

SECTION 1

OPERATION

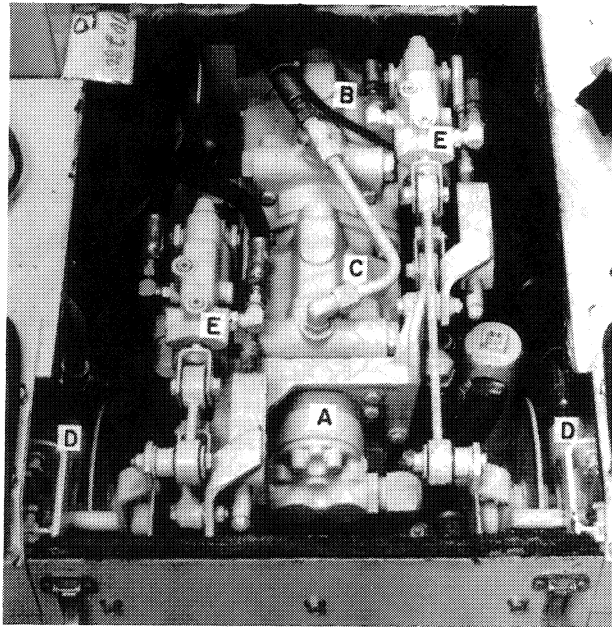

SHIELDS REMOVED FOR CLARITY.

FIGURE 1-1

Figures 1-1 and 1-2 show the hydrostatic transmission and boom hydraulic systems of the skid-steer loader and point out the major components involved.

The New Holland loader features a fully hydrostatic drive with a tandem pump configuration. Two variable displacement piston pumps, B and C, Figure 1-1, operate the propulsion system and one gear pump operates the hydraulic system, A, Figure 1-1. They are assembled as a unit and receive power directly from the engine. The two piston pumps are connected to two piston motors, D, Figure 1-1, (one for each final drive) by high pressure hoses.

The transmission pumps are controlled with two steering control levers. The control levers are connected to two servo cylinders, E, Figure 1-1, which automatically return the pintle arms to a positive neutral position. As the control levers are moved, they stroke the hydrostatic transmission pump pintle arms to the desired position. Hydrostatic pulsations and the torque feedback generated by drive train loads are resisted by the servo cylinder neutralizers, rather than by the operator's arms. This results in smoother operation and less operator fatigue.

Skid-steer loader usage is typified by rapid changes of speed and direction, with accompanying low speeds at times of heavy loader

power demands. It is under those conditions that a hydrostatic transmission is more efficient than a mechanical drive train.



CAUTION!

BE A SAFE OPERATOR. Before attempting to operate the loader, thoroughly acquaint yourself with:

1. The safety information in the Operator's Manual and Skid-Steer Loader Safety Manual.
2. The operating instructions in the Operator's Manual.
3. The controls on the loader.

When a loader digs into a pile of dirt, the operator strives to exert maximum tractive effort with very little speed. The variable displacement hydrostatic units are destroyed so they drive the motors at the required slow speed while generating maximum torque. Minimum power losses occur because input speeds are reduced drastically below levels attainable with slipping clutches as used in mechanical drives.

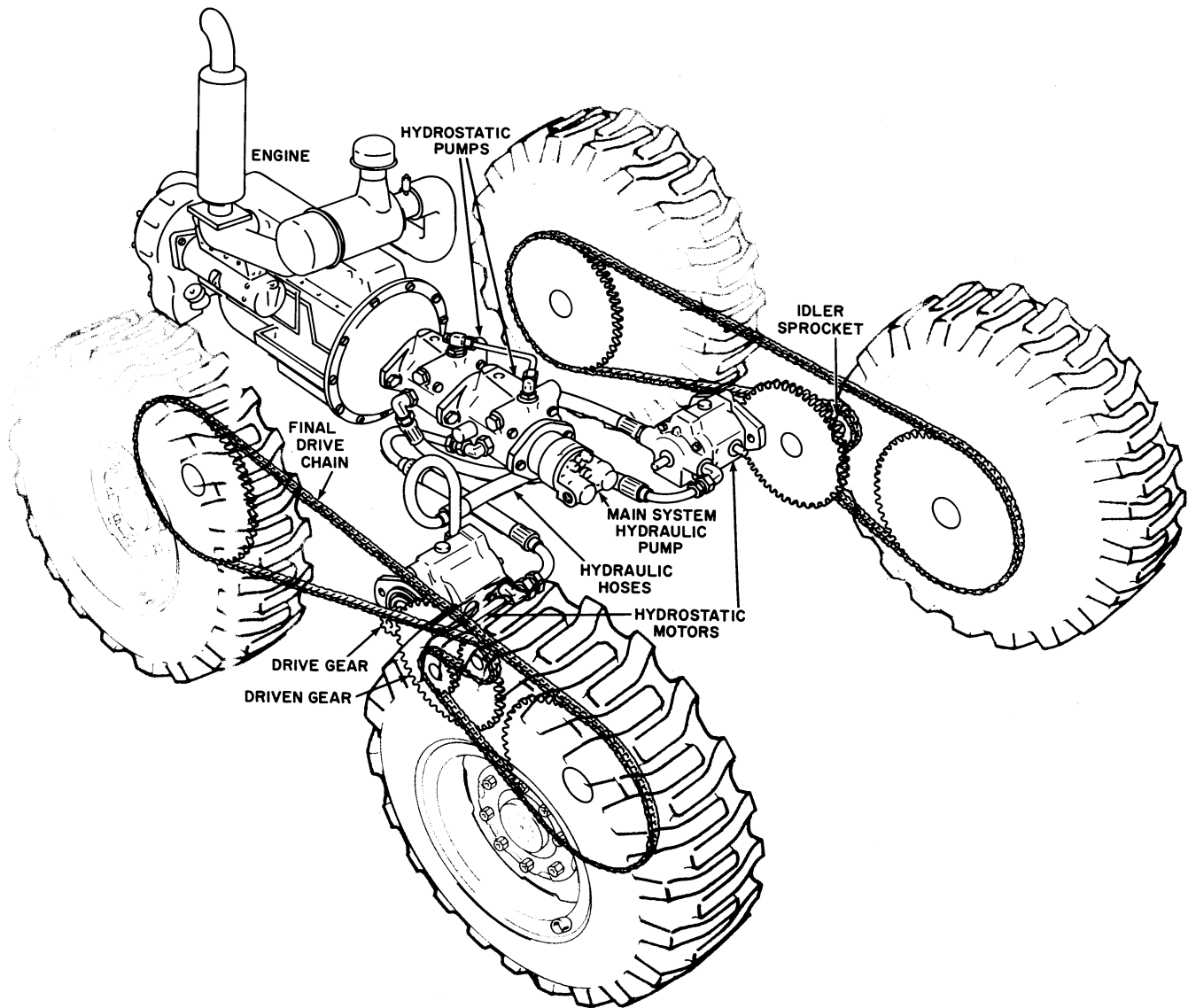

FIGURE 1-2

To obtain maximum torque at the wheels, the control levers should be close to the neutral position. This differs from a mechanical drive unit where the operator pushes the control levers as far forward as possible to prevent the clutches from slipping. The positiveness of the hydrostatic drive at low speeds allows the operator to ease the bucket into loads, rather than using the impact loading technique which is so often necessary when using mechanically driven units.

Because of the positive relationship between the hydrostatic pumps and motors, the units work to aid deceleration of the machine when the pump is stroked toward neutral position. This is the automatic braking characteristic of the hydrostatic drive. Infinitely variable speed

means a full range from full speed reverse through neutral to full speed forward and any speed in between, with no jumps, jerks, or flat spots. Fast shuttle loading work is accomplished with no lost time changing directions. The smooth power application thus gained from the transmissions gives maximum tractive effort on any terrain. The operator can ease the loader into a tough load without breaking traction because he has precise control.

Figure 1-3 shows the hydraulic circuit and components as used on L-780 series loaders. To trace the oil flow through the hydraulic system, start with the chain case reservoir on either side of the loader. A cross tube connects both chain cases and serves as a supply point for oil to the front gear pump.

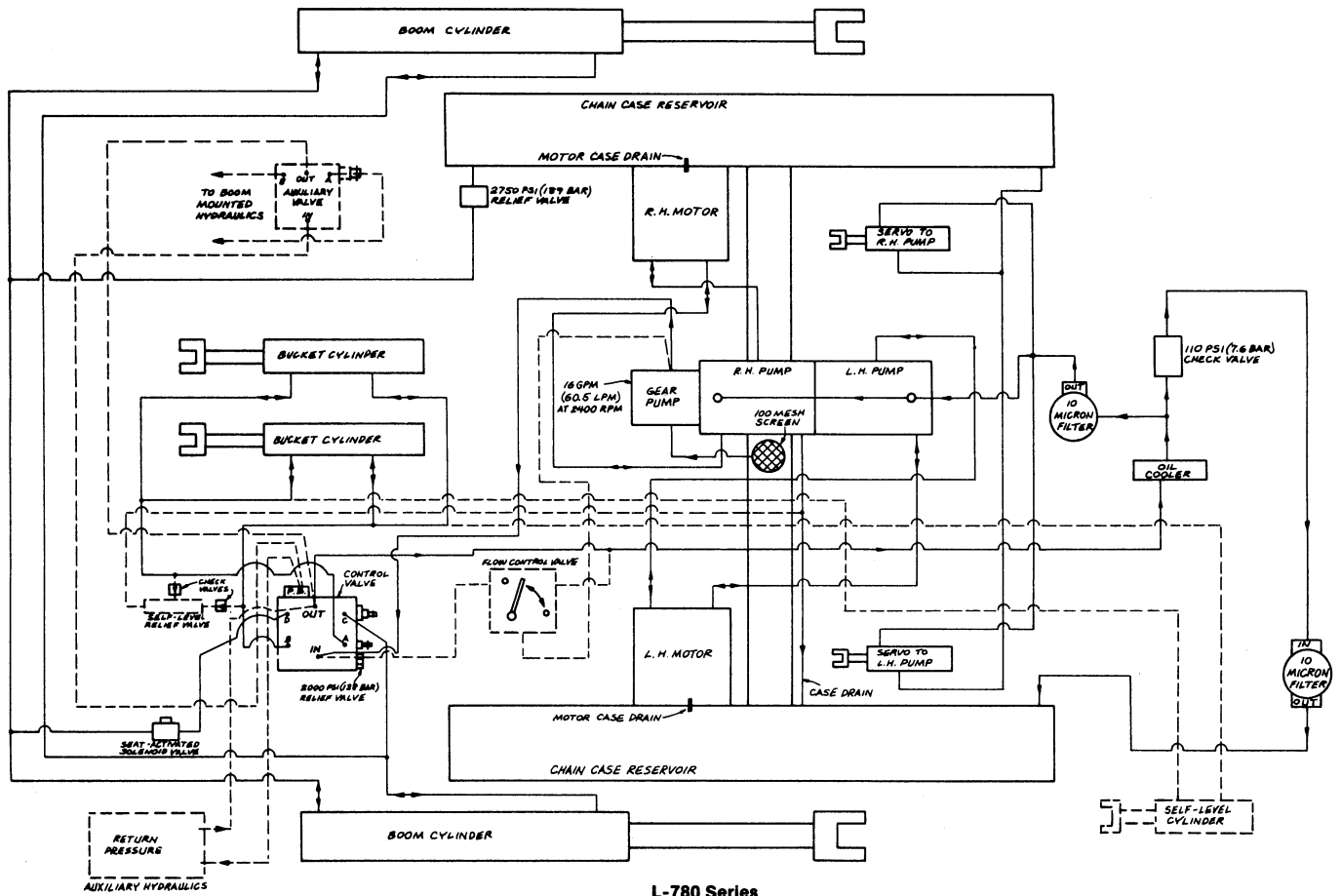

**L-780 Series
LOADER HYDRAULIC DIAGRAM**
----- OPTIONAL EQUIPMENT

FIGURE 1-3

The loader lift system consists of the oil strainer, gear pump, control valve, boom cylinders, and bucket cylinders. Hydraulic oil is pulled from the chain case reservoir through the #100 mesh strainer screen and into the gear pump. The gear pump supplies oil to the main control valve with a master relief valve set at 2000 PSI (13,790 kPa) to limit the maximum system pressure. Oil is then supplied to the boom or bucket cylinders on demand. Return oil from the open center control valve flows through the oil cooler before it is filtered through the 10-micron bypass-type filter and returns to the chain case reservoir. If this filter element plugs, the oil will bypass through the filter base.

A pressure-beyond (PB) fitting supplies oil from the main control valve to the auxiliary hydraulic or auxiliary valve kit if these options have been installed.

The transmission system consists of a charge line filter, two variable displacement piston pumps, and two variable displacement piston motors. The piston motors transfer power to each chain case where the wheels are driven by a gear and roller chain reduction.

Hydraulic oil is supplied to the 10-micron bypass charge line filter from the control valve return oil at 110 PSI (7.6 bar) to provide adequate oil flow to the hydrostatic piston pumps. The left and right piston pumps supply oil to the piston motors whenever the steering levers are activated. A case drain line moves leakage oil from the piston pump cases to the reservoir. The piston motor cases drain directly into the reservoir through the output shaft bearings. The forward and reverse relief valves used on the transmission piston pumps are 5000 PSI (34,475 kPa).

SECTION 2

STEERING ADJUSTMENTS



CAUTION: MAKE ALL ADJUSTMENTS WITH THE ENGINE STOPPED UNLESS OTHERWISE SPECIFIED.

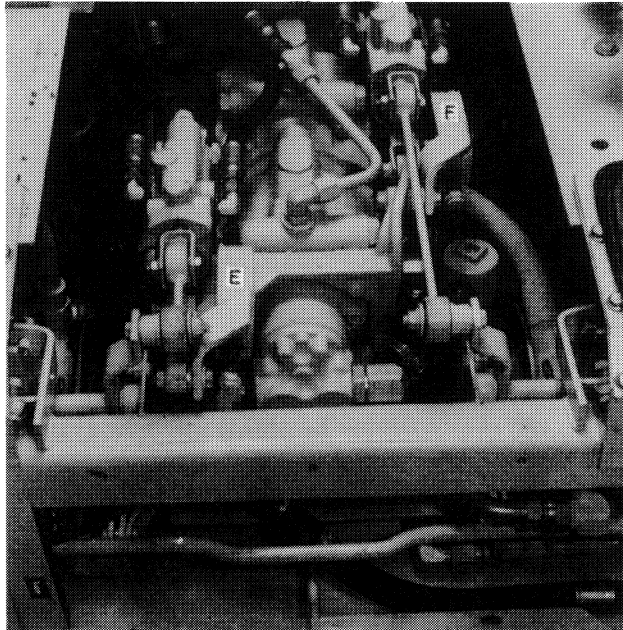

SHIELDS REMOVED FOR CLARITY.

FIGURE 2-1

DRIVE CONTROL ADJUSTMENT PROCEDURE

If the machine creeps or the transmissions make a noise indicating they are being slightly stroked, a neutralizing adjustment is required.



CAUTION: TO MAKE A NEUTRALIZER ADJUSTMENT, BLOCK THE MACHINE OFF THE GROUND SO THE WHEELS TURN FREELY. RAISE THE BOOM AND PLACE IT ON THE BOOM LOCK PINS. WHEN THE ENGINE IS RUNNING, STAY CLEAR OF THE ROTATING WHEELS.

Neutralizer, E, Figure 2-1, controls the right drive wheels. Neutralizer, F, controls the left drive wheels. Check for free play in the neu-

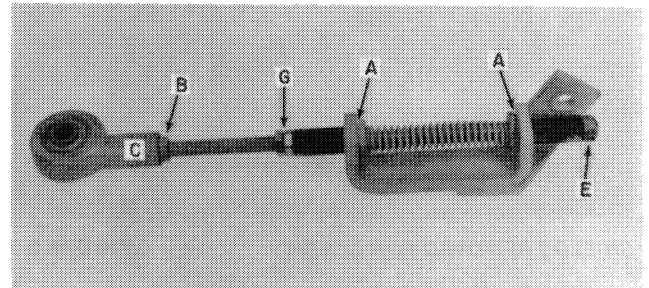

FIGURE 2-2

tralizer spring assembly first at A, Figure 2-2. If free play is found, adjust nuts, G, until no free play is present. Tighten the nuts securely.

If end play is present in the neutralizer, the loader will creep forward when the steering lever is moved forward and released. When the steering lever is pulled in reverse and released, the loader will creep in reverse. This indicates the neutralizer is not returning to the same position each time.

Clean all paint from the nylatron bushings to eliminate any binding in the brackets.

If the loader only creeps in one direction after moving the steering levers in forward and reverse, there is no free play in the neutralizer and only the following creep adjustments should be made.

NOTE: Remove all free play from the neutralizer assembly before adjusting the creep to insure that the steering levers return to the set position each time.

Loosen nut, B, Figure 2-2, retaining the neutralizer bushing assembly, C. Start the engine. If the wheels creep forward, thread one or both neutralizers to the rear at E. Thread the neutralizers to the front if the unit creeps rearward. Stop the engine. Retighten the hardware.

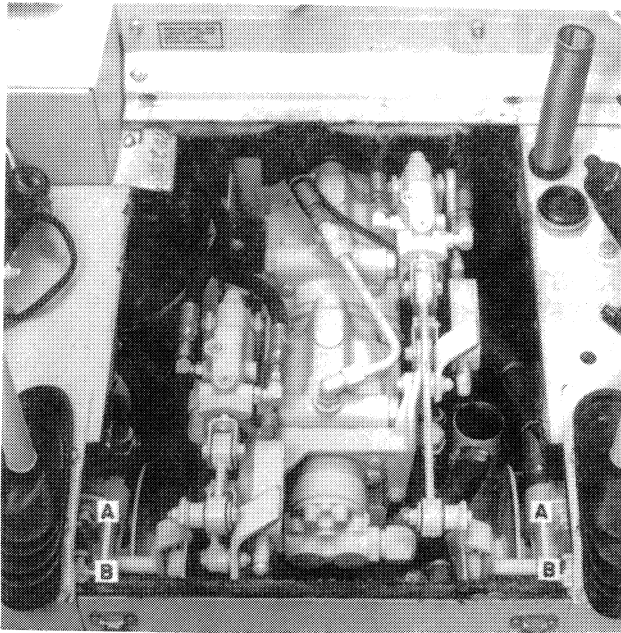

SHIELDS REMOVED FOR CLARITY.

FIGURE 2-3

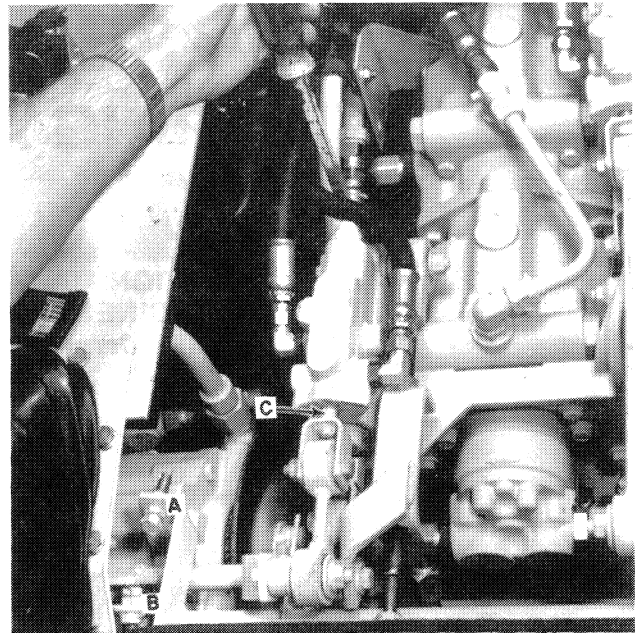

SHIELDS REMOVED FOR CLARITY.

FIGURE 2-4

EXTERNAL STOP BOLT ADJUSTMENT

When the neutralizers are adjusted, the control arm stop bolts must be readjusted. Adjustable stops have been provided for the control levers to prevent overloading of the internal transmission stops.

1. Thread the external stop bolts, A and B, Figure 2-3, away from the center.
2. Move the control lever forward and rearward until the cam plate contacts the internal stop.
3. Hold the servo cylinder in position with the cam plate against the internal stop and allow the control lever to return the servo control spool, C, Figure 2-4, to neutral.

NOTE: It is necessary to use tools as shown in Figure 2-4, to obtain adequate leverage to hold the servo in position.

4. Adjust the external stop bolts against the control lever stop plates and continue turning the stop bolts in toward the center another $\frac{1}{2}$ turn.
5. Repeat the adjustment sequence for front and rear stops on both sides.
6. Adjust for straight travel by using a hand tachometer in the center of the hubs at the same engine RPM, and slow the faster side down to ± 2 RPM of the slower side. Do this for both forward and reverse in low range.

IMPORTANT: If external stops are not accurately set, the transmission pintle shaft and the rubber bushing in the control linkage may fail.

SERVO CYLINDER REPAIR

Removal

1. Disconnect hoses, A, Figure 2-5, from the servo cylinders and cap.
2. Remove the bolts from the linkages at B, Figure 2-5. Be sure to identify all shim washers and spacers so they can be re-assembled correctly.

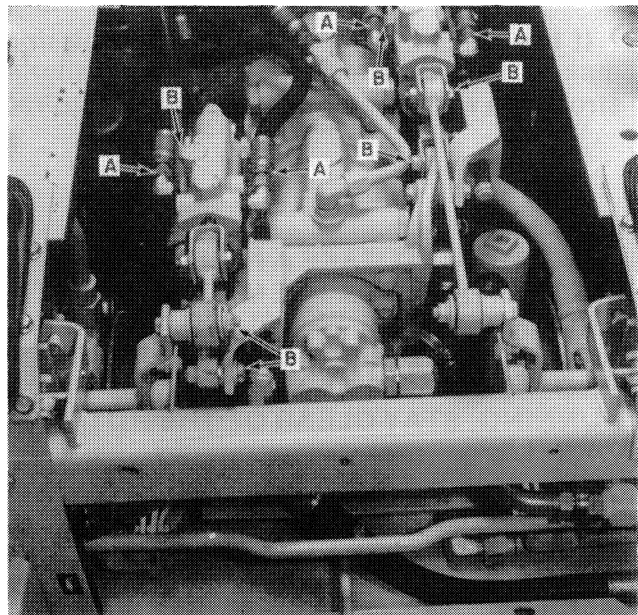

SHIELDS REMOVED FOR CLARITY.

FIGURE 2-5

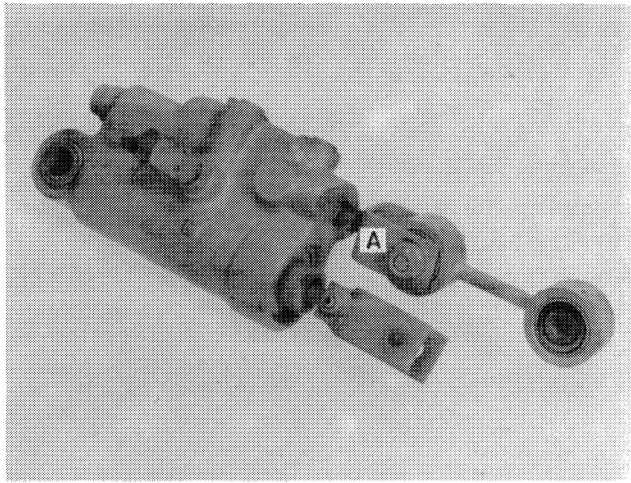

FIGURE 2-6

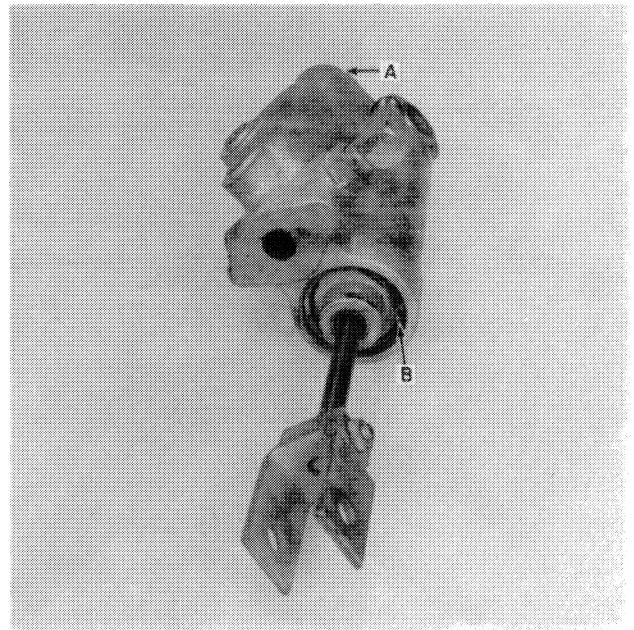

FIGURE 2-8

Servo cylinder overhaul

1. Remove yoke, A, Figure 2-6.
2. Remove spool retaining cap, A, Figure 2-7.
3. Slide the control spool out of the rear of servo, A, Figure 2-8.

4. Remove snap ring, B, Figure 2-8.

Remove the cylinder rod and inspect seal, A, and O rings, B, Figure 2-9. Also check the valve spool and servo for scratches, wear, contamination, binding or any other defects, and either repair or replace.

5. Reverse this procedure to reassemble the cylinder after all parts are cleaned and oiled.

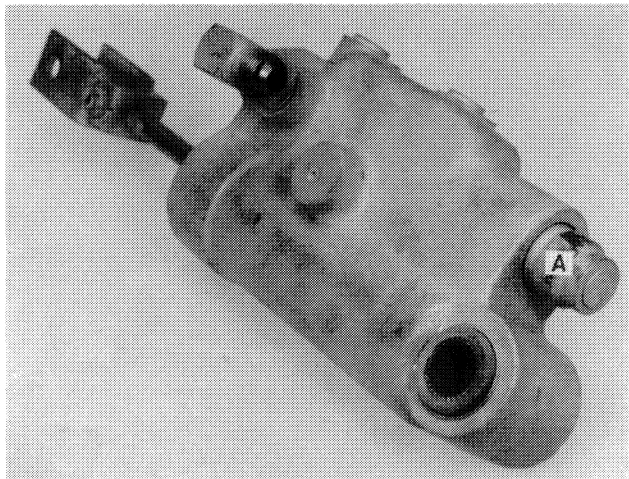

FIGURE 2-7

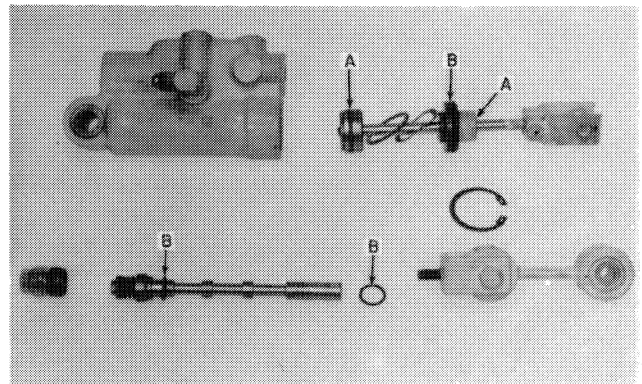
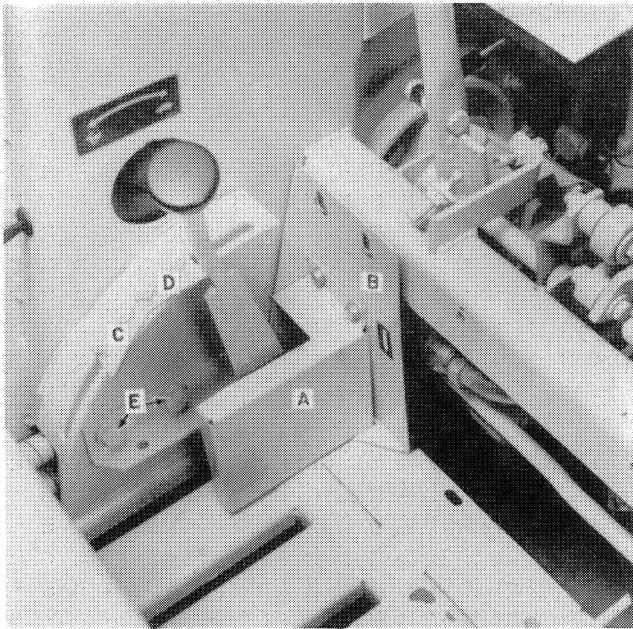
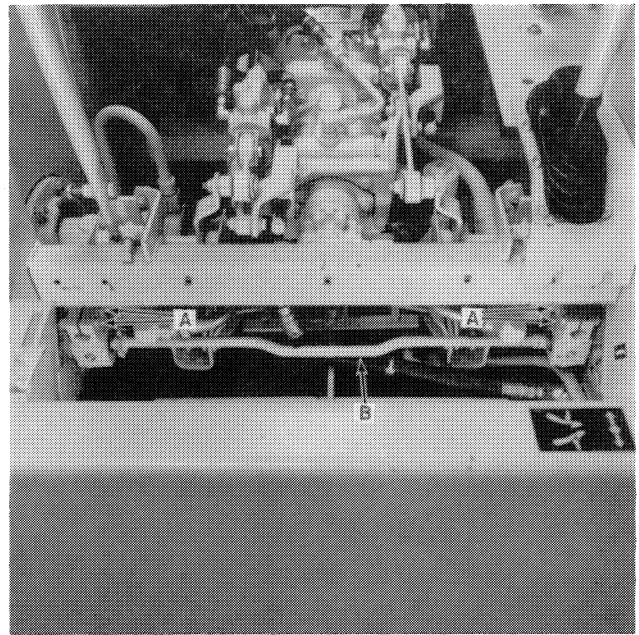

FIGURE 2-9



SHIELDS REMOVED FOR CLARITY.

FIGURE 2-10



SHIELDS REMOVED FOR CLARITY.

FIGURE 2-12

HI/LO RANGE ADJUSTMENTS

Removal

1. Remove shields, A and B, Figure 2-10, and shield, A, Figure 2-11.

NOTE: Remove the connector link and chain before removing shield, B, Figure 2-10.

2. Loosen bolts, A, Figure 2-12, and slide hi/lo shaft, B, off the motor cam plate shafts as shown in Figure 2-13.

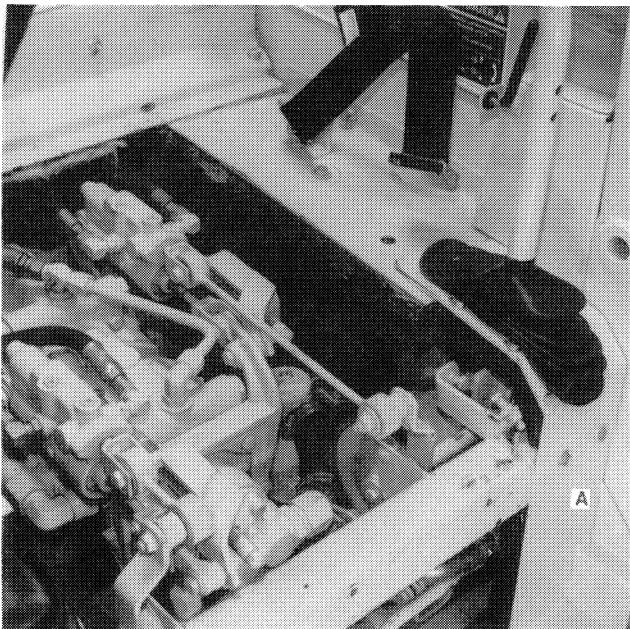

SHIELDS REMOVED FOR CLARITY.

FIGURE 2-11

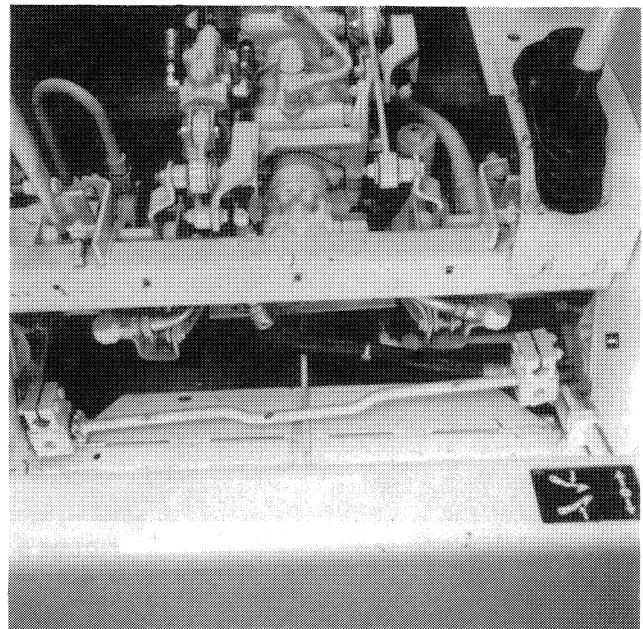

SHIELDS REMOVED FOR CLARITY.

FIGURE 2-13



Suggest:

If the above button click is invalid.

Please download this document

first, and then click the above link

to download the complete manual.

Thank you so much for reading

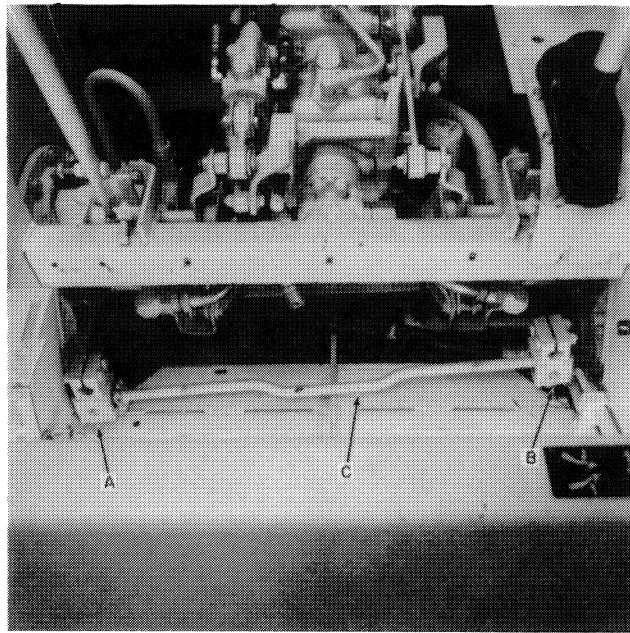

SHIELDS REMOVED FOR CLARITY.

FIGURE 2-14

Installation

1. Install motor screw assemblies, A and B, Figure 2-14, on shaft, C. Screw assembly, B, should be screwed in toward the center of the shaft past the threads.
2. Rotate both motor shafts toward the outside of the loader.
3. Position the square keys on the motor shafts and slide screw, A, on the right motor shaft. Then turn shaft, C, until screw, B, is onto the left motor shaft.
4. Install the chain through shield, B, Figure 2-10, and on the sprockets. Locate the connector link so it does not interfere with the hi/lo shifter handle.
5. Adjust the chain tension using bolts, E, Figure 2-10.
6. Loosen the hi/lo stop adjuster bracket and position it into high. Slide the bracket assembly forward until it takes 6 lbs.-10 lbs. of force (2.72 kg to 4.54 kg) to position the shift past stop, C, Figure 2-10.
7. Slide low range stop, D, Figure 2-10, back until it requires 6 lbs.-10 lbs. of force (2.72 kg to 4.54 kg) to position the lever past stop, D.
8. Install all shields.

LABOR GUIDE

The following labor amounts are listed as a guide only. Working conditions and experience will vary the time it actually takes to complete each job.

Job	Man-Hours
Adjust neutral - both drives	1 hr.
Remove and rebuild one neutralizer assembly	1 hr.
Adjust hi-lo range	1 hr.

<https://www.ebooklibonline.com>

Hello dear friend!

Thank you very much for reading.

Enter the link into your browser.

The full manual is available for immediate download.

<https://www.ebooklibonline.com>