

Tractors  
Series 10  
Series 30

Part 1 –  
Engine Systems  
Part 2 –  
Fuel Systems

Vol. 1

---



---

# SERVICE MANUAL



**NEW HOLLAND**

## NOTE

Some of the information in this manual is reprinted from the previous Repair Manual as the service information contained herein is equally applicable to the new Series 10 and Series 30 models. First check the appropriate section to see if the model has a specific chapter. If no model is shown, the model numbers have been updated as follows:

<b>From</b>	<b>-</b>	<b>To</b>
Ford 2600	-	Ford 2610
Ford 3600	-	Ford 3610, 2810, 3230, or 3430
Ford 4100	-	Ford 4110, 3910, or 3930
Ford 4600	-	Ford 4610, 4630
Ford 5600	-	Ford 5610
Ford 6600	-	Ford 6610
Ford 6700	-	Ford 6710
Ford 7600	-	Ford 7610, 7810*
Ford 7700	-	Ford 7710, 8210**

Tractor models 7810 and 8210 have been added to this manual. Both tractors utilize the 401 CID engine from the TW Series tractors. The engine repair information from the TW Repair Manual is reprinted at the end of Section 1 for your benefit.

\* The Model 7810 tractor is based on the Model 7610 tractor with the exception of a modified, derated TW-5 engine. Repair procedures for the 7610 should be followed except for the engine proper. Refer to the TW-5 material for engine repair. One important exception must be noted. The Model 7810 engine oil pump location and drive is the same as the Model 7610.

\*\* The Model 8210 tractor is based on the Model 7710 tractor with exception of a derated TW-5 engine. Repair procedures for the 7710 should be followed except for the engine proper. Refer to the TW-5 material for engine repair.

Both Models 7810 and 8210 utilize the same inline fuel injection pump used on the TW-5 tractor. Fuel delivery specifications vary. Any repair or adjustment must be carried out by an authorized fuel injection repair service.

Ford New Holland, Inc.

## **FOREWORD**

This Service Manual provides information for the correct servicing and overhaul of the Ford Series 10 and Series 30 3- and 4-cylinder agricultural tractors, including derivative models, and is an essential publication for all service personnel carrying out repairs or maintenance on these tractors. We recommend that this manual be available for reference at all times.

The Service Manual consists of fourteen Parts contained in six volumes. A Table of Contents is included in each volume which lists all fourteen Parts and the volume where each can be found. Five Parts have been reprinted from the prior Repair Manual as the service information in these five Parts is still valid for the new model series. A page giving a model cross reference is included in the front of each volume to advise the reader to transpose model numbers.

All Parts are subdivided into Chapters which convey information on general operating principles, detailed inspection and overhaul procedures and, where applicable, specifics on troubleshooting, special tools and specifications. Any reference in this manual to right, left, rear, front, top or bottom is as viewed from the operator's seat.

The information contained herein was correct at the time of going to print but Ford New Holland, Inc. policy is one of continuous improvement and the right to change prices, specifications, equipment or design at any time without notice is reserved. All data in this manual is subject to production variations and the illustrations do not necessarily depict tractors to standard build specifications.

Ford New Holland, Inc.

**<https://www.ebooklibonline.com>**

Hello dear friend!

Thank you very much for reading.

Enter the link into your browser.

The full manual is available for immediate download.

**<https://www.ebooklibonline.com>**

# SAFETY PRECAUTIONS

Practically all Service work involves the need to drive the tractor. The Operators Manual, supplied with each tractor, contains detailed safety precautions relating to Driving, Operating and Servicing that tractor. These precautions are as applicable to the service technician as they are to the operator, and should be read, understood and practised by all personnel.

Prior to undertaking any maintenance, repair, overhaul, dismantling or re-assembly operations, whether within a workshop facility or out "in the field", consideration should be given to factors that may have an effect upon Safety. Not only upon the mechanic carrying out the work, but also upon bystanders.

## PERSONAL CONSIDERATIONS

- The wrong clothes or carelessness in dress can cause accidents. Check to see that you are suitably clothed.  
Some jobs require special protective equipment.
- **Eye Protection**  
The smallest eye injury may cause loss of vision. Injury can be avoided by wearing eye protection when engaged in chiselling, grinding, discing, welding, painting, etc.
- **Breathing Protection**  
Fumes, dust and paint spray are unpleasant and harmful. These can be avoided by wearing respiratory protection.
- **Hearing Protection**  
Loud noise may damage your hearing and the greater the exposure the worse the damage. If you feel the noise excessive wear ear protection.
- **Hand Protection**  
It is advisable to use a protective cream before work to prevent irritation and skin contamination. After work clean your hands with soap and water. Solvents such as white spirit, paraffin, etc., may harm the skin.
- **Foot Protection**  
Substantial or protective footwear with reinforced toe-caps will protect your feet from falling objects. Additionally oil-resistant soles will help to avoid slipping.
- **Special Clothing**  
For certain work it may be necessary to wear flame- or acid- resistant clothing.
- Avoid injury through incorrect handling of components. Make sure you are capable of lifting the object. If in doubt get help.

## EQUIPMENT CONSIDERATIONS

- **Machine Guards**  
Before using any machine, check to ensure that the machine guards are in position and serviceable. These guards not only prevent parts of the body or clothing coming in contact with the moving parts of the machine, but also ward off objects that might fly off the machine and cause injury.
- **Lifting Appliances**  
Always ensure that lifting equipment, such as chains, slings, lifting brackets, hooks and eyes are thoroughly checked before use. If in doubt, select stronger equipment than is necessary.  
Never stand under a suspended load or raised implement.
- **Compressed Air**  
The pressure from a compressed air line is often as high as 100 lbf/in<sup>2</sup> (6.9 bar) (7 kgf/cm<sup>2</sup>). It is perfectly safe if used correctly. Any misuse may cause injury.  
Never use compressed air to blow dust, swarf, dirt, etc., away from your work area unless the correct type of nozzle is fitted.  
Compressed air is not a cleaning agent, it will only move dust, etc., from one place to another. Look around before using an air hose as bystanders, may get grit into their eyes, ears or skin.

- **Hand Tools**

Many cuts, abrasions and injuries are caused by defective or improvised tools. Never use the wrong tool for the job, as this generally leads either to some injury, or to a poor job.

Never use

- A hammer with a loose head or split handle.
- Spanners or wrenches with splayed or worn jaws.
- Spanners or files as hammers; or drills, clevis pins or bolts as punches.

For removing or replacing hardened pins use a copper or brass drift rather than a hammer.

For dismantling, overhaul and re-assembly of major and sub components, always use the Special Service Tools recommended.

These will reduce the work effort, labour time and the repair cost.

Always keep tools clean and in good working order.

- **Electricity**

Electricity has become so familiar in day to day usage, that it's potentially dangerous properties are often overlooked. Misuse of electrical equipment can endanger life.

Before using any electrical equipment — particularly portable appliances — make a visual check to ensure that the cable is not worn or frayed and that the plugs, sockets, etc., are intact. Make sure you know where the nearest isolating switch for your equipment is located.

## GENERAL CONSIDERATIONS

- **Solvents**

Use only cleaning fluids and solvents that are known to be safe. Certain types of fluids can cause damage to components such as seals, etc., and can cause skin irritation. Solvents should be checked that they are suitable not only for the cleaning of components and individual parts, but also that they do not affect the personal safety of the user.

- **Housekeeping**

Many injuries result from tripping or slipping over, or on, objects or material left lying around by a careless worker. Prevent these accidents from occurring. If you notice a hazard, don't ignore it — remove it.

A clean, hazard-free place of work improves the surroundings and daily environment for everybody.

- **Fire**

Fire has no respect for persons or property. The destruction that a fire can cause is not always fully realised. Everyone must be constantly on guard.

- Extinguish matches/cigars/cigarettes, etc., before throwing them away.
- Work cleanly, disposing of waste material into proper containers.
- Locate the fire extinguishers and find out how to operate them.
- Do not panic — warn those near and raise the alarm.
- Do not allow or use an open flame near the tractor fuel tank, battery or component parts.

- **First Aid**

In the type of work that mechanics are engaged in, dirt, grease, fine dusts, etc., all settle upon the skin and clothing. If a cut, abrasion or burn is disregarded it may be found that a septic condition has formed within a short time. What appears at first to be trivial could become painful and injurious. It only takes a few minutes to have a fresh cut dressed, but it will take longer if you neglect it. Make sure you know where the First Aid box is located.

- **Cleanliness**

Cleanliness of the tractor hydraulic system is essential for optimum performance. When carrying out service and repairs plug all hose ends and component connections to prevent dirt entry.

Clean the exterior of all components before carrying out any form of repair. Dirt and abrasive dust can reduce the efficiency and working life of a component and lead to costly replacement. Use of a high pressure washer or steam cleaner is recommended.

## OPERATIONAL CONSIDERATIONS

- Stop the engine, if at all possible, before performing any service.
- Place a warning sign on tractors which, due to service or overhaul, would be dangerous to start. Disconnect the battery leads if leaving such a unit unattended.
- Do not attempt to start the engine while standing beside the tractor or attempt to by-pass the safety start switch.
- Avoid prolonged running of the engine in a closed building or in an area with inadequate ventilation as exhaust fumes are highly toxic.
- Always turn the radiator cap to the first stop, to allow pressure in the system to dissipate when the coolant is hot.
- Never work beneath a tractor which is on soft ground. Always take the unit to an area which has a hard working surface — concrete for preference.
- If it is found necessary to raise the tractor for ease of servicing or repair, ensure that safe and stable supports are installed, beneath axle housings, casings, etc., before commencing work.
- Certain repair or overhaul procedures may necessitate “separating the tractor”, either at the engine/front transmission or front transmission/rear transmission connections. These operations are simplified by the use of the Tractor Splitting Kit/Stands. Should this equipment not be available, then every consideration must be given to stability, balance and weight of the components, especially if a cab is installed.
- Use footsteps or working platforms when servicing those areas of a tractor that are not within easy reach.
- Before loosening any hoses or tubes connecting implements to remote control valves, etc., switch off the engine, remove all residual pressure in the lines by moving operating levers several times. This will remove the danger of personal injury by oil spurt.
- Prior to pressure testing, ensure all hoses and connectors, not only of the tractor, but also those of the test equipment, are in good condition and tightly secured. Pressure readings must be taken with the gauges specified. The correct procedure should be rigidly observed to prevent damage to the system or the equipment, and to eliminate the possibility of personal injury.
- When equipment or implements are required to be attached to the hydraulic linkage, either for testing purposes or for transportation, then “position control” should be engaged.
- Always lower equipment to the ground when leaving the tractor.
- If high lift attachments are fitted to a tractor beware of overhead power, electric or telephone cables when travelling. Drop attachment near to ground level to increase stability and minimise risks.
- Do not park or attempt to service a tractor on an incline. If unavoidable, take extra care and block all wheels.
- Observe recommended precautions as indicated in this Repair Manual Part 13 when dismantling the air conditioning system as escaping refrigerant can cause frostbite.
- Prior to removing wheels and tyres from a tractor, check to determine whether additional ballast (liquid or weights) has been added. Seek assistance and use suitable equipment to support the weight of the wheel assembly.
- When inflating tyres beware of over inflation — constantly check the pressure. Over inflation can cause tyre burst and result in personal injury.

Safety precautions are very seldom the figment of someone’s imagination. They are the result of sad experience, where most likely someone has paid dearly through personal injury.

Heed these precautions and you will protect yourself accordingly. Disregard them and you may duplicate the sad experience of others.

**Safety is everybody’s responsibility.**

# CONTENTS

<b>Part 1 – Engine Systems</b> .....	<b>Vol. 1</b>
<b>Part 2 – Fuel Systems</b> .....	<b>Vol. 1</b>
<b>Part 3 – Electrical Systems</b> <b>Chapter 1 to Chapter 8</b> .....	<b>Vol. 2A</b>
<b>Part 3 – Electrical Systems</b> <b>Chapter 9 to Chapter 14</b> .....	<b>Vol. 2B</b>
<b>Part 4 – Clutches</b> .....	<b>Vol. 3</b>
<b>Part 5 – Transmission Systems</b> .....	<b>Vol. 3</b>
<b>Part 6 – Power Take-Off</b> .....	<b>Vol. 3</b>
<b>Part 7 – Rear Axle &amp; Brakes</b> .....	<b>Vol. 4</b>
<b>Part 8 – Hydraulic Systems</b> .....	<b>Vol. 4</b>
<b>Part 9 – Steering Systems</b> .....	<b>Vol. 4</b>
<b>Part 10 – Front Axle</b> .....	<b>Vol. 5</b>
<b>Part 11 – Safety Cabs &amp; Platforms</b> .....	<b>Vol. 5</b>
<b>Part 12 – Separating the Tractor</b> .....	<b>Vol. 6</b>
<b>Part 13 – Accessories &amp; General</b> .....	<b>Vol. 6</b>
<b>Part 14 – Model Derivatives</b> .....	<b>Vol. 6</b>

# PART 1 ENGINE SYSTEMS

## Chapter 1 DIESEL ENGINES

Section	Page
A. DIESEL ENGINE—DESCRIPTION AND OPERATION	1
B. DIESEL ENGINE—OVERHAUL	4

### A. DIESEL ENGINE—DESCRIPTION AND OPERATION

This Chapter describes the overhaul and repair of the Ford Tractor direct injection diesel engines. The Chapter covers the 3 and 4-cylinder engines, the latter in both the normally aspirated and turbocharged forms, Figures 1, 2, 3 and 4.

The engines feature cross flow cylinder heads with the inlet and exhaust manifolds on opposite sides of the head. The combustion chamber is formed in the crown of the piston which has three compression and one oil control ring, all located above the piston pin.

All the engines are of similar design and hence service procedures are basically common throughout the range. The major difference between the engines is that the 4-cylinder units are fitted with a dynamic engine balancer and the Ford 7610 and 7710 engines are turbocharged.

The cylinder head assembly incorporates the valves, valve springs and spring retainers. Valve guides are an integral part of the cylinder head with replaceable valve seats pressed into the valve ports.

The following chart shows the 3 and 4-cylinder diesel engine options available.

Model	Ford 2610	Ford 3610	Ford 4110	Ford 4610	Ford 5610	Ford 6610 & 6710	Ford 7610 & 7710 (Turbo-charged)
No. of Cylinders	3	3	3	3	4	4	4
Bore	4.2 in. (106.7 mm)	4.4 in. (111.8 mm)	4.4 in. (111.8 mm)	4.4 in. (111.8 mm)	4.4 in. (111.8 mm)	4.4 in. (111.8 mm)	4.4 in. (111.8 mm)
Stroke	4.2 in. (106.7 mm)	4.2 in. (106.7 mm)	4.4 in. (111.8 mm)	4.4 in. (111.8 mm)	4.2 in. (106.7 mm)	4.4 in. (111.8 mm)	4.4 in. (111.8 mm)
Displacement	175 in <sup>3</sup> (2868 cm <sup>3</sup> )	192 in <sup>3</sup> (3147 cm <sup>3</sup> )	201 in <sup>3</sup> (3294 cm <sup>3</sup> )	201 in <sup>3</sup> (3294 cm <sup>3</sup> )	256 in <sup>3</sup> (4195 cm <sup>3</sup> )	268 in <sup>3</sup> (4393 cm <sup>3</sup> )	268 in <sup>3</sup> (4393 cm <sup>3</sup> )

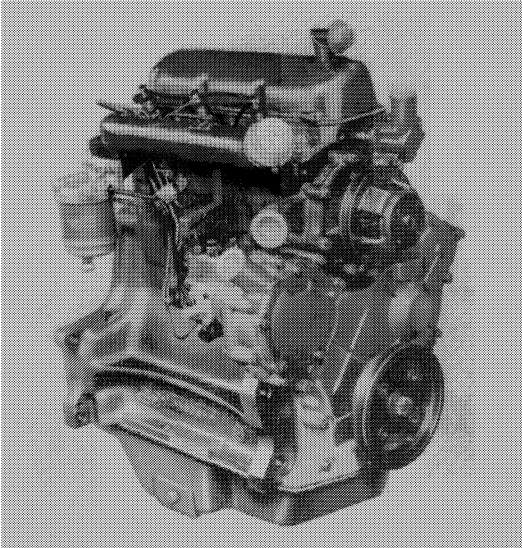

**Figure 1**

3-Cylinder Diesel Engine with Distributor Type Fuel Injection Pump

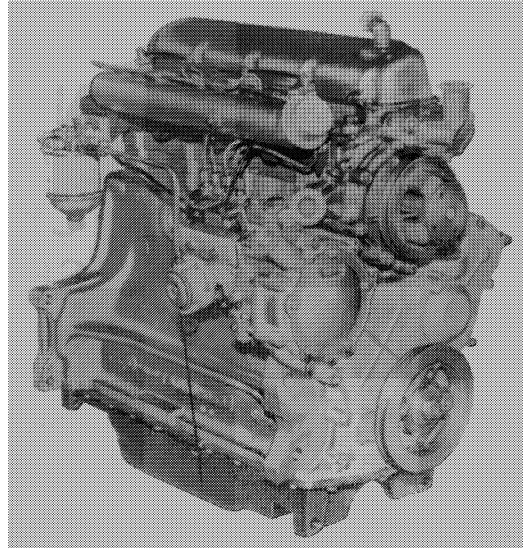

**Figure 3**

4-Cylinder Diesel Engine with In-Line Type Fuel Injection Pump

The crankshaft is supported in the cylinder block by four main bearings for the 3-cylinder engine and five main bearings for the 4-cylinder engine. Crankshaft end thrust is suppressed by a thrust bearing located on the second main bearing of the 3-cylinder engine and the centre (third) main bearing of the 4-cylinder engine.

Front and rear crankshaft oil sealing is effected by one piece, single lip type seals.

The crankshaft rear main bearing carrier block is sealed by two composition type side seals and a gasket positioned between the block and the engine rear adaptor plate.

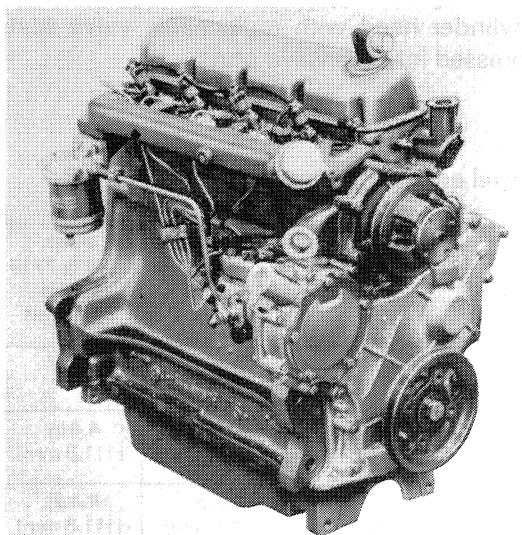

**Figure 2**

4-Cylinder Diesel Engine with Distributor Type Fuel Injection Pump

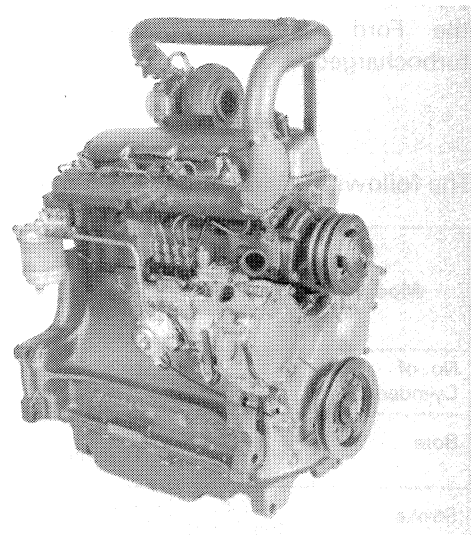

**Figure 4**

4-Cylinder Turbocharged Diesel Engine with In-Line Type Fuel Injection Pump

A crankshaft driven dynamic balancer, installed on the 4-cylinder engines, counteracts out-of-balance forces and thereby reduces engine vibration. The balancer housing is bolted to the bottom of the cylinder block and contains two meshing gears which are driven and timed from a gear machined on the crankshaft.

The piston connecting rods are of 'I' section and for the turbocharged engines a centrally drilled hole facilitates both pressure lubrication of the piston pin bushing and cooling of the piston crown.

The fully floating piston pin is retained in the piston by two snap rings.

## LUBRICATION SYSTEM

Lubrication of the engine is maintained by a rotor type oil pump mounted at the base of the engine block. The oil pump is driven from the camshaft and draws oil from the engine sump through a wire mesh screen.

A spring loaded relief valve in the pump body limits the pressure in the system by directing excess oil back to the intake side of the pump.

Oil passes from the pump to an external, **throw-away, spin on type filter** incorporating a relief valve which permits oil to be bypassed, if filter blockage occurs, and so ensures engine lubrication at all times.

Oil flows from the filter to the main oil gallery which runs the length of the cylinder block and intersects the camshaft follower chambers.

The main gallery also supplies oil to the crankshaft main bearings and to the connecting rod journals via drillings in the crankshaft. Drilled passages from each main bearing direct oil to the camshaft bearings.

The camshaft drive gear bushing is pressure lubricated through a drilled passage from the front main bearing. The gear has small oil passages machined on both sides which allow the oil to escape.

The timing gears are lubricated by oil from the cam follower chamber and the pressure lubricated camshaft drive gear bushing.

On the 4-cylinder engines, the dynamic balancer is lubricated through a drilled passage from the cylinder block intermediate thrust bearing web to the balancer housing. Oil flows through the balancer housing to the drilled balancer gear shafts and onto the bushings in the balancer gears.

Cylinder walls, pistons and piston pins are splash lubricated by the connecting rods and rotating crankshaft.

An intermittent flow of oil is directed to the valve rocker arm shaft assembly via a drilled passage in the cylinder block located vertically above the No. 1 camshaft bearing. This drilling aligns with a corresponding hole in the cylinder head. As the camshaft turns, holes in the camshaft and camshaft bearing align and a regulated stream of oil is directed to the cylinder head and on up the rocker arm shaft support bolt to the rocker shaft. The oil flows from the shaft through drilled holes in each rocker arm bushing to lubricate both ends of the arms. Excess oil flows down the push rods and assists in lubricating the cam followers before draining back into the sump through cored openings in the block.

For the Ford 6610, 6710, 7610 and 7710 engines, a **water-to-oil type oil cooler**, located in the base of the radiator is connected into the lubrication system main oil gallery and cools a proportion of the circulating oil. A restrictor at the oil outlet limits the flow to the cooler and maintains internal lubrication at low engine speeds. Return oil from the cooler is fed back to the engine sump via a pipe tapped into the skirt of the cylinder block.

**B. ENGINE—OVERHAUL**

**CYLINDER HEAD, VALVES AND RELATED PARTS**

**REMOVAL**

**NOTE:** *The cylinder head can be removed with the engine installed in the tractor.*

1. Disconnect the battery.

Ford 2610, 3610, 4110, 4610, 5610, 6610 and 7610:

- Remove the battery and battery tray.
- Remove the vertical muffler (where fitted).

2. Drain the radiator and cylinder block.

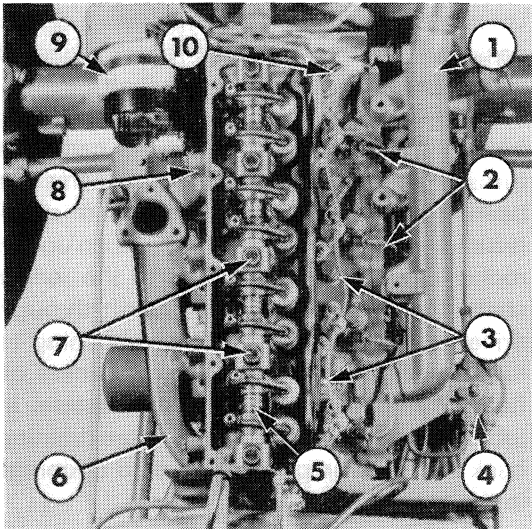

**Figure 5**

4-Cylinder Engine with Rocker Arm Cover Removed

1. Intake Manifold
2. Injection Tubes
3. Leak-Off Tubes
4. Fuel Filter
5. Rocker Shaft Assembly
6. Exhaust Manifold
7. Rocker Shaft Retaining Bolts
8. Tab Washer
9. Alternator
10. Cold Start Tube

3. Shut off the heater hose taps then disconnect and plug the heater hoses.
4. Remove the radiator top hose.
5. Shut off the main fuel tank tap.

Ford 2610, 3610, 4110, 4610, 5610, 6610 and 7610:

- Remove the hood panel assembly.
- Remove the radiator shell support.
- Remove the two bolts securing the fuel tank to the hood rear support.
- Disconnect the horizontal type exhaust pipe (where fitted) from the exhaust manifold.
- Disconnect the air inlet hose at the clamp at the intake manifold.

Ford 6710 and 7710:

- Remove the main fuel tank. See "FUEL SYSTEMS"—Part 2.
6. Disconnect and remove the rocker cover ventilation tube.

Ford 7610 and 7710:

- Remove the turbocharger assembly. See "FUEL SYSTEMS"—Part 2.
7. Disconnect the alternator, oil pressure, temperature sender, air cleaner restriction indicator and cold start wiring harness connections (where fitted).

8. Remove the alternator and guard (where fitted), Figure 5.

Ford 2610, 3610, 4110, 4610, 5610, 6610 and 6710:

- Remove the vertical type exhaust pipe and bracket (where fitted).

9. Bend the lock tabs back, withdraw the attaching bolts and remove the exhaust manifold and gasket.
10. Disconnect the cold start equipment (where fitted).
11. Remove the injector lines from the fuel injection pump and the injectors. Cap the exposed openings in the pump, injectors and tube ends.
12. Disconnect the fuel lines and remove the fuel filter(s) from the inlet manifold.
13. Withdraw the retaining bolts and lock-washers and remove the inlet manifold and gasket.

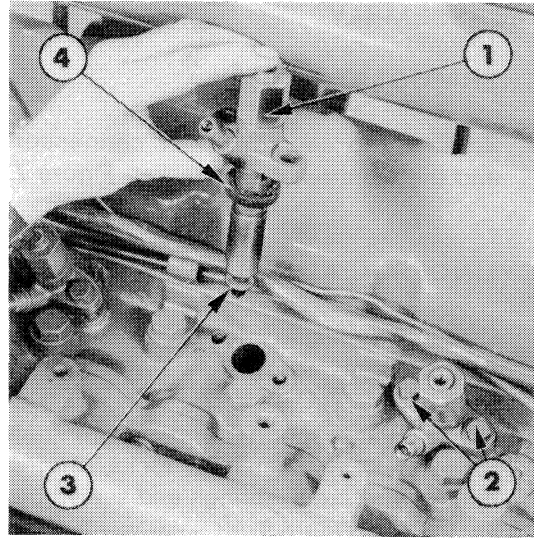

**Figure 6**

Fuel Injector Removed

1. Fuel Injector Assembly
2. Fuel Injector Mounting Bolts
3. Copper Washer
4. Cork Washer

Ford 6710 and 7710:

- Place a block under the hood frame rear support and remove the four bolts attaching the support to the rear of the cylinder head.
14. Withdraw the securing bolts and remove the rocker arm cover and gasket from the cylinder head.
  15. Hold the leak-off pipe at each injector and carefully disconnect the fuel injector leak-off pipes. Clean the area surrounding the fuel injectors then remove the bolts and carefully withdraw the fuel injectors and washers, Figure 6.
  16. Check the push rods for straightness by rotating the rods with the valve closed and identify any bent rods.

17. Loosen the rocker shaft retaining bolts, which also serve as cylinder head bolts, evenly and alternately. Remove the rocker shaft assembly.

**NOTE:** Leave the bolts in the rocker shaft supports during removal as they retain the supports on the shaft.

18. Remove the push rods and place in a numbered rack.
19. Remove the remaining cylinder head bolts and washers working inwards from the ends to the centre of the head.
20. Lift the cylinder head from the block. If necessary lever the head off on the pads provided, taking care not to damage the cylinder head or block faces.

**DISASSEMBLY**

**THERMOSTAT:**

1. Remove the coolant outlet connection and the thermostat and gasket, Figure 7.

**CYLINDER HEAD:**

2. Clean the head and remove carbon deposits from around the valve heads.
3. Using a valve spring compressor, Figure 8, remove the retainer locks, spring retainers/rotators, springs and seals from each valve, Figure 9.
4. Withdraw the valves and place in a numbered rack together with the valve rotators (where fitted).

**ROCKER SHAFT ASSEMBLY:**

5. Remove the cylinder head bolts which pass through the rocker shaft supports and slide the rocker shaft components from the shaft, Figure 10.

**INSPECTION AND REPAIR**

**CYLINDER HEAD:**

1. Scrape all gasket surfaces clean then wash the cylinder head in a suitable solvent and thoroughly dry with a lint free cloth or compressed air.
2. Inspect the cylinder head for damage and, if necessary, remove nicks and burrs from the gasket faces using a suitable abrasive. Ensure all traces of abrasive material are removed after repair.
3. Use a straight edge to check the flatness of the cylinder head in all directions, Figure 11. For flatness requirement see "Specifications" — Chapter 4.

**NOTE:** *If the cylinder head exceeds the flatness specification it may be skimmed providing the depth from the lower face of the valve insert to the cylinder head face is not less than 0.064 in. (1.63 mm).*

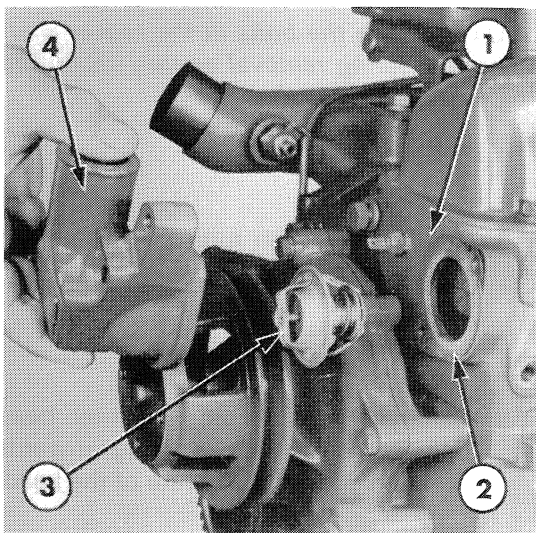

**Figure 7**

Coolant Outlet and Thermostat Removal

1. Cylinder Head
2. Gasket
3. Thermostat
4. Coolant Outlet Connection

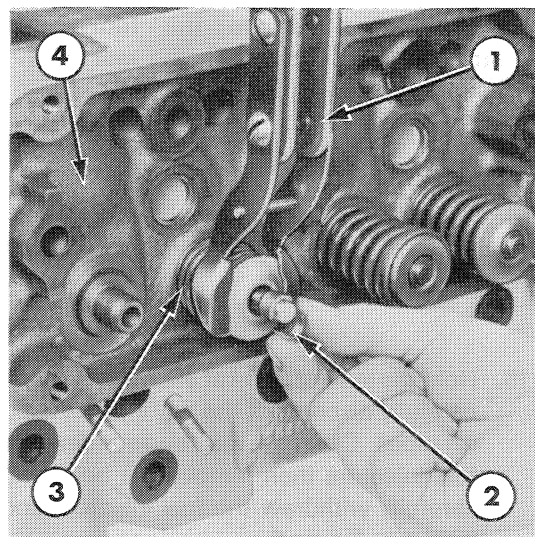

**Figure 8**

Valve Removal

1. Valve Spring Compressor
2. Retainer Locks
3. Valve Spring
4. Cylinder Head

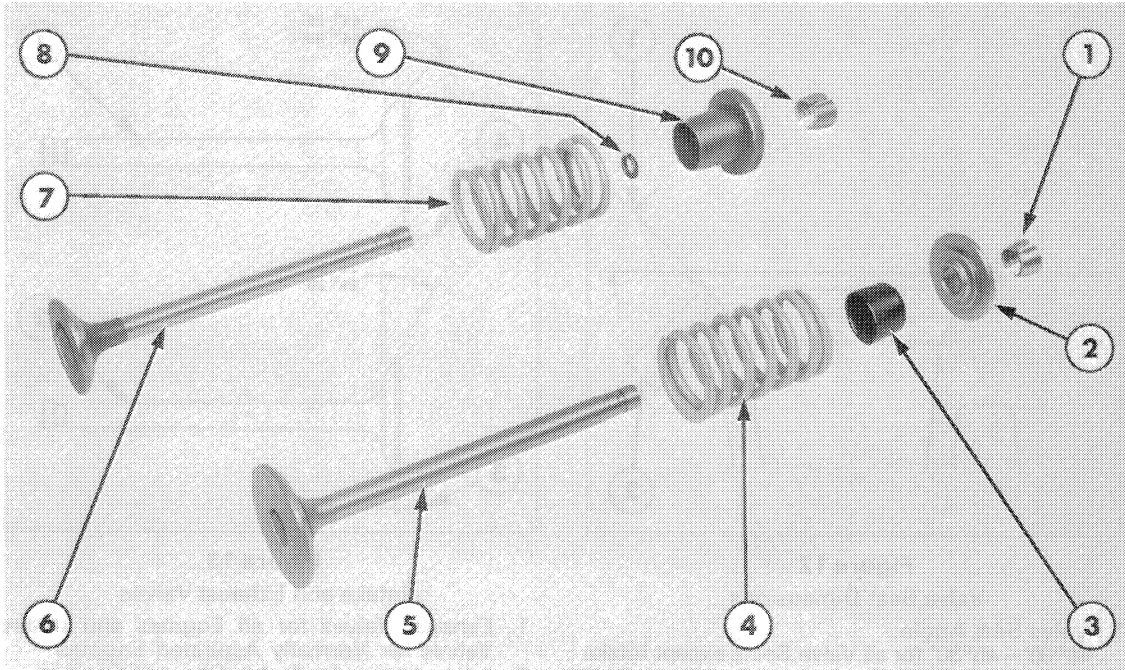

**Figure 9**

Valve Assembly Components

- |                                      |   |
|--------------------------------------|---|
| 1. Intake Valve Spring Retainer Lock | 6. Exhaust Valve                        |
| 2. Intake Valve Spring Retainer      | 7. Exhaust Valve Spring                 |
| 3. Intake Valve Seal                 | 8. Exhaust Valve Seal                   |
| 4. Intake Valve Spring               | 9. Exhaust Valve Spring Retainer        |
| 5. Intake Valve                      | 10. Exhaust Valve Spring Retainer Locks |

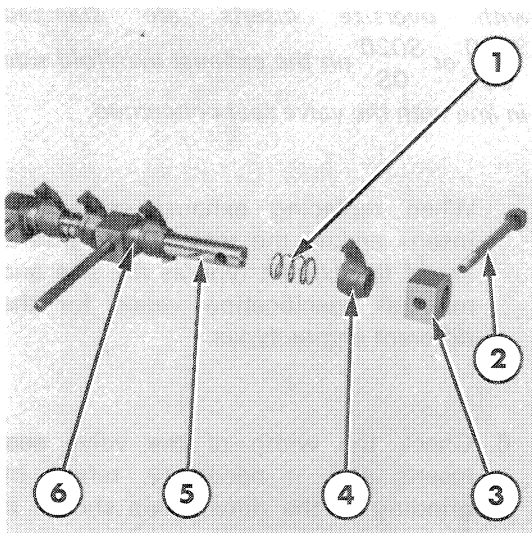

**Figure 10**

Rocker Shaft Disassembled

- |                   |               |
|-------------------|---------------|
| 1. Spring         | 4. Rocker Arm |
| 2. Retaining Bolt | 5. Shaft      |
| 3. Shaft Support  | 6. Spacer     |

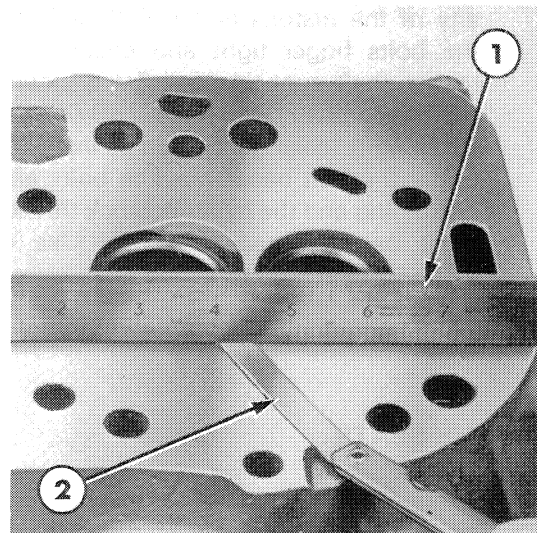

**Figure 11**

Measuring Cylinder Head Flatness

- |                  |
|------------------|
| 1. Straight Edge |
| 2. Feeler Gauge  |

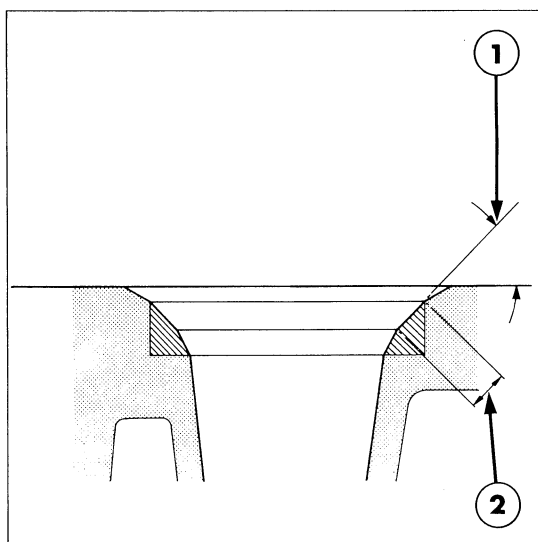

**Figure 12**  
Valve Seat Dimensions

1. Valve Seat Angle:  
45°00'—45°30' for all Valve Seats except Intake Valve Seat on Turbocharged Engines to be 30°00'—30°30'
2. Valve Seat Width:  
Intake 0.080–0.102 in (2.032–2.590 mm)  
Exhaust 0.084–0.106 in (2.133–2.692 mm)

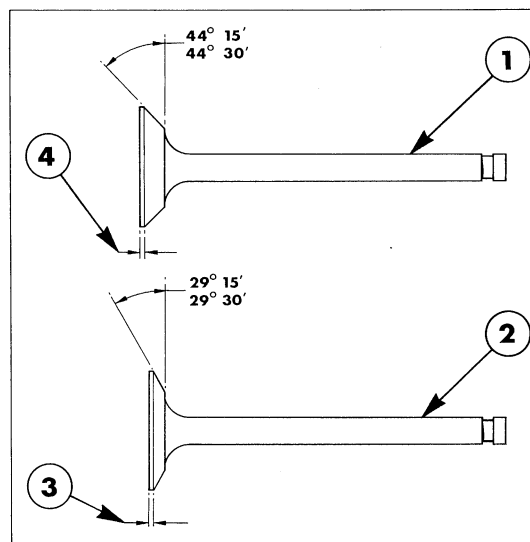

**Figure 13**  
Intake and Exhaust Valves

1. Exhaust Valves for all Engines and Intake Valves for Normally Aspirated Engines
2. Intake Valves for Turbo-Charged Engines
3. Dimension after Refacing:  
0.062 in. (1.58 mm) Minimum
4. Dimension after Refacing:  
0.031 in. (0.79 mm) Minimum

4. After skimming the head, check whether any cylinder head bolts are bottoming by mounting the cylinder head on the block without a gasket and without any of the pistons at T.D.C. Install all the bolts finger tight and ensure the rocker shaft supports and flat washers are fitted with the long bolts. If a 0.010 in. (0.25 mm) feeler gauge can be inserted under the bolt head then the bolts are bottoming and the cylinder block thread must be increased in depth. Use a ½ in. × 13 UNC–2A thread tap.

**NOTE:** Valve seat inserts of 0.010 in. (0.25 mm) and 0.020 in. (0.5 mm) oversize on diameter are sometimes installed in cylinder heads in production. Heads fitted with oversize inserts are stamped S010 or S020 OS or OS on the exhaust manifold side in line with the valve seat concerned.

When replacing exhaust valve seat inserts ensure the replacement inserts are of the correct type as the size and material specification varies for the different engine types.

### VALVE SEATS:

5. Examine the valve seat inserts and reface if pitted but replace if damaged. If necessary, install an oversize insert by machining the seat counterbore in the cylinder head, see "Specifications"—Chapter 4. The insert must be chilled in dry-ice prior to installation.

6. Check the width of the valve seat inserts and, if necessary, reface by grinding to the dimensions shown in Figure 12.

**NOTE:** Refacing of the valve seat should always be co-ordinated with refacing of the valve to ensure a compression tight fit.

**VALVES:**

7. Examine the valve face and, if pitted, replace or reface by grinding to the dimension shown in Figure 13. Before refacing the valve, ensure the valve stem is not bent or worn and check the valve seat run-out, measured at right-angles to the seat, does not exceed a total of 0.0015 in. (0.038 mm).

**IMPORTANT:** *The finished valve seat should contact the centre of the valve face. Using the refaced or new valve, check the seat using Prussian Blue. Rotate the valve with a light pressure and if the blue is transferred to the middle of the valve face, the contact is correct.*

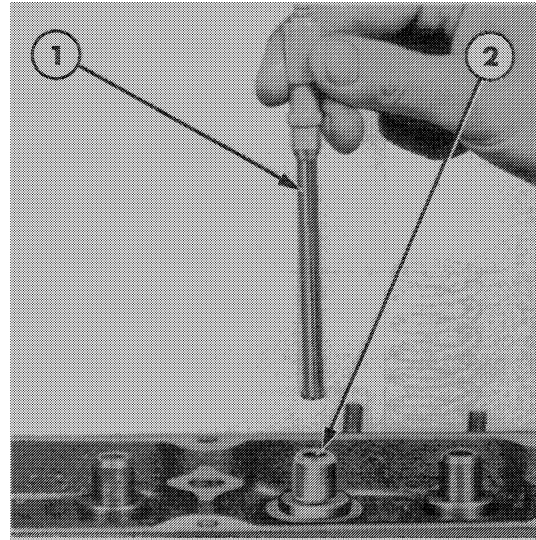

**Figure 14**

Measuring Valve Guide

1. Telescopic Gauge
2. Valve Guide

**VALVE GUIDES:**

8. Using a telescopic gauge and micrometer, measure the valve to guide clearance, Figure 14. If the clearance exceeds the specified limits, see "Specifications"—Chapter 4, ream the valve guide to fit the next oversize valve.

**NOTE:** *Production cylinder heads may have one or more 0.015 in. (0.38 mm) oversize valve guides and valves installed. Such cylinder heads have 15 or V015 stamped on the exhaust manifold side of the head opposite the valve(s) concerned.*

9. Use Kit No. FT.6202 or 2136 to ream out the valve guide to accept an oversize valve. The kit contains three reamer and pilot combinations as follows:

- 0.003 in. (0.076 mm) Oversize Reamer and Standard Diameter Pilot
- 0.015 in. (0.38 mm) Oversize Reamer and 0.003 in. (0.076 mm) Oversize Pilot
- 0.030 in. (0.76 mm) Oversize Reamer and 0.015 in. (0.38 mm) Oversize Pilot.

When going from a standard valve stem to an oversize always use the reamers in sequence. After reaming a valve guide, always check the valve seating and reface if necessary.



**Suggest:**

**If the above button click is invalid.**

**Please download this document**

**first, and then click the above link**

**to download the complete manual.**

**Thank you so much for reading**

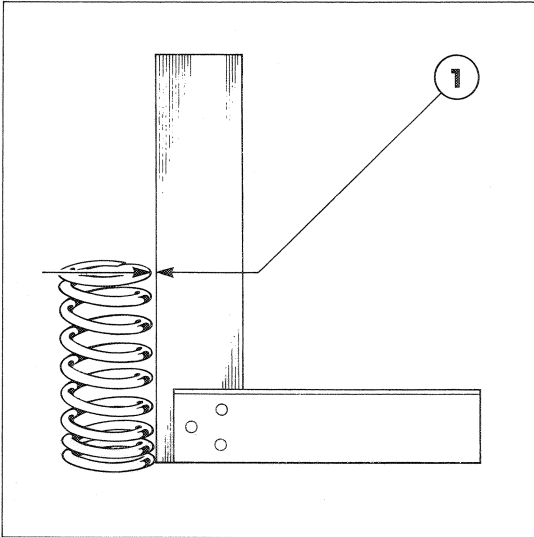

**Figure 15**

Checking Valve Spring Squareness

1. Maximum Out-of-Squareness  
0.06 in. (1.5 mm)

**VALVE SPRINGS:**

10. Replace worn or damaged valve springs. Check for squareness and reject if out-of-squareness exceeds 0.06 in. (1.5 mm), Figure 15. Check the free length and loaded length of each valve spring, see "Specifications"—Chapter 4. Ensure the valve spring retainers locks are in good condition and the exhaust valve rotators are not binding or worn.

**ROCKER SHAFT ASSEMBLY:**

11. Examine the rocker arm for wear or damage. Check the adjusting screw threads and replace if damaged. Inspect the rocker arm locating springs and spacers for damage. Check the rocker arm-to-shaft clearances and replace if beyond specified limits, see "Specifications"—Chapter 4.
12. Clean the shaft in a suitable solvent and thoroughly dry with compressed air ensuring the oil passages are free from obstruction.

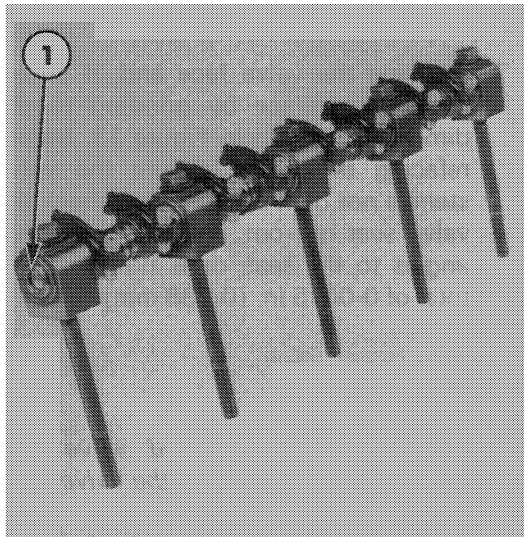

**Figure 16**

Rocker Shaft Installation

1. Notch

**THERMOSTAT:**

13. For inspection and repair of the coolant outlet or thermostat, see "Cooling System"—Chapter 2.

**RE-ASSEMBLY**

**CYLINDER HEAD:**

1. Insert each valve in the guide bore from which it was removed and lap in position to ensure an even seat around the valve. Withdraw the valve and ensure removal of all traces of lapping compound.
2. Use a valve spring compressor to re-assemble the valves, valve springs, retainers and retainer locks. For the exhaust valves install a new sealing ring in the second groove from the top of the valve stem.

**NOTE:** Turbocharged engines have no seals fitted to the intake valves.

**<https://www.ebooklibonline.com>**

Hello dear friend!

Thank you very much for reading.

Enter the link into your browser.

The full manual is available for immediate download.

**<https://www.ebooklibonline.com>**