

SERVICE MANUAL

E35B SR / E39B SR Mini Excavator

Part number 47574267B
English
March 2014



Contents

INTRODUCTION

Engine.....	10
[10.001] Engine and crankcase	10.1
[10.102] Pan and covers	10.2
[10.106] Valve drive and gears	10.3
[10.101] Cylinder heads	10.4
[10.105] Connecting rods and pistons.....	10.5
[10.103] Crankshaft and flywheel.....	10.6
[10.216] Fuel tanks	10.7
[10.218] Fuel injection system.....	10.8
[10.202] Air cleaners and lines	10.9
[10.250] Turbocharger and lines.....	10.10
[10.254] Intake and exhaust manifolds and muffler	10.11
[10.400] Engine cooling system	10.12
[10.304] Engine lubrication system.....	10.13
Hydraulic systems.....	35
[35.000] Hydraulic systems.....	35.1
[35.300] Reservoir, cooler, and filters.....	35.2
[35.106] Variable displacement pump	35.3
[35.359] Main control valve.....	35.4
[35.355] Hydraulic hand control	35.5
[35.356] Hydraulic foot control.....	35.6
[35.352] Hydraulic swing system	35.7
[35.353] Hydraulic travel system	35.8
[35.354] Hydraulic central joint	35.9
[35.736] Boom hydraulic system	35.10
[35.737] Dipper hydraulic system.....	35.11

[35.738] Excavator and backhoe bucket hydraulic system	35.12
[35.360] Hammer and rotating bucket hydraulic system	35.13
[35.739] Swing arm hydraulic system	35.14
[35.741] Dozer blade cylinders	35.15
Frames and ballasting	39
[39.101] Upper frame	39.1
[39.103] Swing ring assembly	39.2
[39.140] Ballasts and supports	39.3
Tracks and track suspension	48
[48.130] Track frame and driving wheels	48.1
[48.100] Tracks	48.2
[48.134] Track tension units	48.3
[48.138] Track rollers	48.4
Cab climate control	50
[50.200] Air conditioning	50.1
Electrical systems	55
[55.000] Electrical system	55.1
[55.100] Harnesses and connectors	55.2
[55.015] Engine control system	55.3
[55.201] Engine starting system	55.4
[55.301] Alternator	55.5
[55.302] Battery	55.6
[55.011] Fuel tank system	55.7
[55.013] Engine oil system	55.8
[55.512] Cab controls	55.9
[55.404] External lighting	55.10
[55.510] Cab or platform harnesses and connectors	55.11
Booms, dippers, and buckets	84

<https://www.ebooklibonline.com>

Hello dear friend!

Thank you very much for reading.

Enter the link into your browser.

The full manual is available for immediate download.

<https://www.ebooklibonline.com>

[84.114] Boom pivoting support	84.1
[84.910] Boom	84.2
[84.912] Dipper arm	84.3
[84.100] Bucket	84.4
Dozer blade and arm.....	86
[86.110] Dozer blade	86.1
Platform, cab, bodywork, and decals	90
[90.150] Cab	90.1
[90.110] Operator platform less cab	90.2
[90.114] Operator protections	90.3
[90.105] Machine shields and guards	90.4
[90.116] Fenders and guards	90.5



INTRODUCTION

Foreword - Important notice regarding equipment servicing

All repair and maintenance work listed in this manual must be carried out only by qualified dealership personnel, strictly complying with the instructions given, and using, whenever possible, the special tools.

Anyone who performs repair and maintenance operations without complying with the procedures provided herein shall be responsible for any subsequent damages.

The manufacturer and all the organizations of its distribution chain, including - without limitation - national, regional, or local dealers, reject any responsibility for damages caused by parts and/or components not approved by the manufacturer, including those used for the servicing or repair of the product manufactured or marketed by the manufacturer. In any case, no warranty is given or attributed on the product manufactured or marketed by the manufacturer in case of damages caused by parts and/or components not approved by the manufacturer.

The information in this manual is up-to-date at the date of the publication. It is the policy of the manufacturer for continuous improvement. Some information could not be updated due to modifications of a technical or commercial type, or changes to the laws and regulations of different countries.

In case of questions, refer to your NEW HOLLAND CONSTRUCTION Sales and Service Networks.

Safety rules

Personal safety





This is the safety alert symbol. It is used to alert you to potential personal injury hazards. Obey all safety messages that follow this symbol to avoid possible death or injury.

Throughout this manual you will find the signal words DANGER, WARNING, and CAUTION followed by special instructions. These precautions are intended for the personal safety of you and those working with you.

Read and understand all the safety messages in this manual before you operate or service the machine.

 DANGER indicates a hazardous situation that, if not avoided, will result in death or serious injury.

 WARNING indicates a hazardous situation that, if not avoided, could result in death or serious injury.

 CAUTION indicates a hazardous situation that, if not avoided, could result in minor or moderate injury.

FAILURE TO FOLLOW DANGER, WARNING, AND CAUTION MESSAGES COULD RESULT IN DEATH OR SERIOUS INJURY.

Machine safety

NOTICE: Notice indicates a situation that, if not avoided, could result in machine or property damage.

Throughout this manual you will find the signal word Notice followed by special instructions to prevent machine or property damage. The word Notice is used to address practices not related to personal safety.

Information

NOTE: Note indicates additional information that clarifies steps, procedures, or other information in this manual.

Throughout this manual you will find the word Note followed by additional information about a step, procedure, or other information in the manual. The word Note is not intended to address personal safety or property damage.

Personal safety

NOTICE: The proper and safe lubrication and maintenance for this machine, recommended by Manufacturer, are outlined in the OPERATOR'S MANUAL for the machine.

Improper performance of lubrication or maintenance procedures are dangerous and could result in injury or death. Read and understand the MANUAL before performing any lubrication or maintenance.

The serviceman or mechanic may be unfamiliar with many of the systems on this machine. This makes a careful use of the systems very important when performing maintenance operations. Sound knowledge of the system and or components is important before the removal or disassembly of any component.

Because of the size of some of the machine components, the serviceman or mechanic should check the weights noted in this manual. Use proper lifting procedures when removing any components. Weight of components table is shown in this section.

The following is a list of basic precautions that must always be observed.

1. Read and understand all Warning plates and decals on the machine before Operating, Maintaining or Repairing this machine.
2. Always wear protective glasses and protective shoes when working around machines. In particular, wear protective glasses when using hammers, punches or drifts on any part of the machine or attachments. Use welders gloves, hood/goggles, apron and the protective clothing appropriate to the welding job being performed. Do not wear loose fitting or torn clothing. Remove all rings from fingers, loose jewellery, confine long hair and loose clothing before working on this machinery.
3. Disconnect the battery and hang a "Maintenance in Progress" tag in the operator's seat. Remove starter key.
4. If possible, make all repairs with the machine parked on a level and firm surface. Block the machine so it does not roll while working on or under the machine. Hang a "Maintenance in Progress" tag in the operator's seat.
5. Do not work on any machine that is supported only by lift, jacks or a hoist. Always use blocks or stops for the jack before carrying out any disassembly operation.

NOTICE: Do not operate this machine unless you have read and understood all instructions contained in this manual. Improper machine operation is dangerous and could result in injury or death.

6. Relieve all pressure in air, oil or water systems before any lines, fittings or related items are disconnected or removed. Always make sure all raised components are blocked correctly and be alert for possible pressure when disconnecting any device from a system under pressure.
7. Lower the bucket, dozer or other attachments to the ground before performing any work on the machine. If this cannot be done, make sure the bucket, blade or other attachment is blocked correctly to prevent it from dropping unexpectedly.
8. Use steps and grab handles when mounting or dismounting a machine. Remove any debris or mud from steps, walkways or work platforms before using them. Always face the machine when using steps, ladders and walkways. When it is not possible to use the designed access system, provide ladders, scaffolds, or work, platforms to perform safe repair operations.
9. To avoid back injury, use a hoist when lifting components which weigh 20 kg (44.09 lb) or more. Make sure all chains, hooks, slings, etc., are in good condition and are the correct capacity. Be sure hooks are positioned correctly. Lifting eyes are not to be side loaded during a lifting operation.
10. To avoid burns, be alert for hot parts and surfaces immediately after stopping the machine such as hot fluids in lines, tubes and compartment covers.
11. Be careful when removing cover plates. Gradually back off the last two capscrews or nuts located at opposite ends of the cover or device and carefully pry the cover loose to relieve any spring or other pressure, before removing the last two capscrews or nuts completely.
12. Be careful when removing filler caps, breathers and plugs on the machine. Hold a rag over the cap or plug to prevent being sprayed or splashed by liquids under pressure. Danger is even greater if the machine has just been stopped, as liquids might be boiling hot.
13. Always use the proper tools that are in good condition and that are suited for the job at hand. Be sure you understand how to use them before performing any service work.
14. Reinstall all clamps with the same spare part number. Do not use clamps of inferior quality if replacement is necessary.

INTRODUCTION

15. Repairs which require welding should be performed only with the benefit of the appropriate reference information and by personnel adequately trained and skilled in welding procedures. Determine the type of metal being welded and select the correct welding procedure and electrodes, rods or wires to provide a metal weld strength at least equivalent to that of the parent metal. Make sure to disconnect the battery before any welding operation is performed.
16. Do not damage wiring during removal operations. Reinstall the wiring so it is not damaged nor will be damaged in operation of the machine by contacting sharp corners, or by rubbing against some object or hot surface. Do not connect wiring to a line containing fluid.
17. Be sure all protective devices, including guards and shields, are properly installed and functioning correctly before starting a repair. If a guard or shield must be removed to perform the repair work, use extra caution and replace the guard or shield after repair is complete.
18. Performing maintenance and repair operations while the bucket is lifted is dangerous, because there is the possibility of a device falling. Do not fail to lower such device and place the bucket to the ground before starting the operation.
19. Loose or dirty fuel, lubrication and hydraulic systems, pipes and hoses may cause fires. Do not bend or strike high-pressure lines, do not install bent or damaged lines. Inspect lines, tubes and hoses carefully. Do not check for leaks with your hands. Very small (pinhole) leaks can result in a high velocity oil jet that will be invisible close to the hose.
This oil can penetrate the skin and cause personal injury. Use card-board or paper to locate pinhole leaks.
20. Tighten connections to the correct torque. Make sure that all protections against burns, the clamps and the operator's protective devices are correctly installed in order to prevent excessive heat, vibrations or rubbing against other parts during operation. Shields that protect against oil spray onto hot exhaust components in event of a line, tube or seal failure must be installed correctly.
21. Do not operate a machine if any rotating part is damaged or contacts any other part during operation. Any high speed rotating component that has been damaged or altered should be checked for balance before reusing.
22. Be careful when servicing or separating the tracks. Chips can fly when removing or installing a track pin. Wear safety glasses and long sleeve protective clothing. Tracks can unroll very quickly when separated. Keep away from front and rear of machine. The machine can move unexpectedly when both tracks (crawlers) are disengaged from the sprockets. Block the machine to prevent it from moving.

Part identification

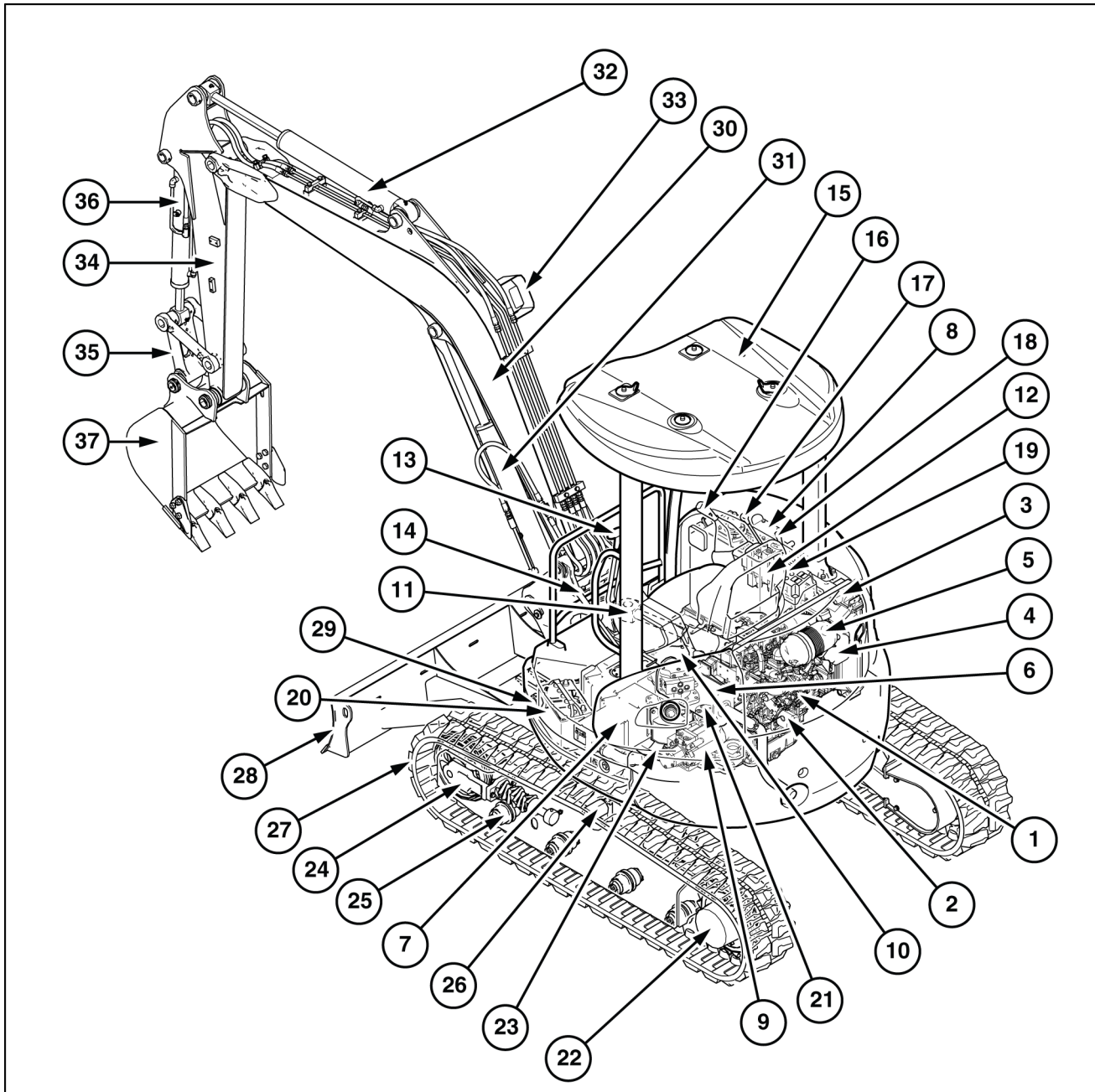

TUL112EXN6006GB 1

- | | | |
|-----------------------|-------------------------|---------------------|
| 1. Engine | 14. Safety lever | 27. Rubber crawler |
| 2. Oil filter | 15. Canopy | 28. Dozer |
| 3. Radiator | 16. Operating lever | 29. Dozer cylinder |
| 4. Reservoir tank | 17. Dozer control lever | 30. Boom |
| 5. Air cleaner | 18. Throttle lever | 31. Boom cylinder |
| 6. Muffler | 19. Gauge cluster | 32. Arm cylinder |
| 7. Fuel tank | 20. Battery | 33. Light |
| 8. Hydraulic oil tank | 21. Swivel joint | 34. Arm |
| 9. Hydraulic pumps | 22. Travel motor | 35. Link |
| 10. Slewing motor | 23. Slewing ring | 36. Bucket cylinder |
| 11. Swing cylinder | 24. Idler adjuster | 37. Bucket |
| 12. Control valve | 25. Lower roller | |
| 13. Travel lever | 26. Upper roller | |



SERVICE MANUAL

Engine

**E35B SR
E39B SR**

Engine - External view

1. Filler port (engine oil)
2. Turbocharger
3. Air intake port (from air cleaner, optional)
4. Lifting eye
5. Coolant pump
6. Fan
7. Crankshaft V-pulley
8. V-belt
9. Filler port (engine oil)
10. Drain plug (engine oil)
11. Engine oil cooler (4TNV98T, 4TNV106 and 4TNV106T)
12. Engine oil filter
13. Dipstick (engine oil)
14. Fuel injection pump
15. Governor lever
16. Fuel filter
17. Fuel cock
18. Fuel filter mounting
19. Lifting eye
20. Engine name plate
21. Rocker arm cover
22. Flywheel
23. Starter motor
24. Exhaust manifold
25. Generator

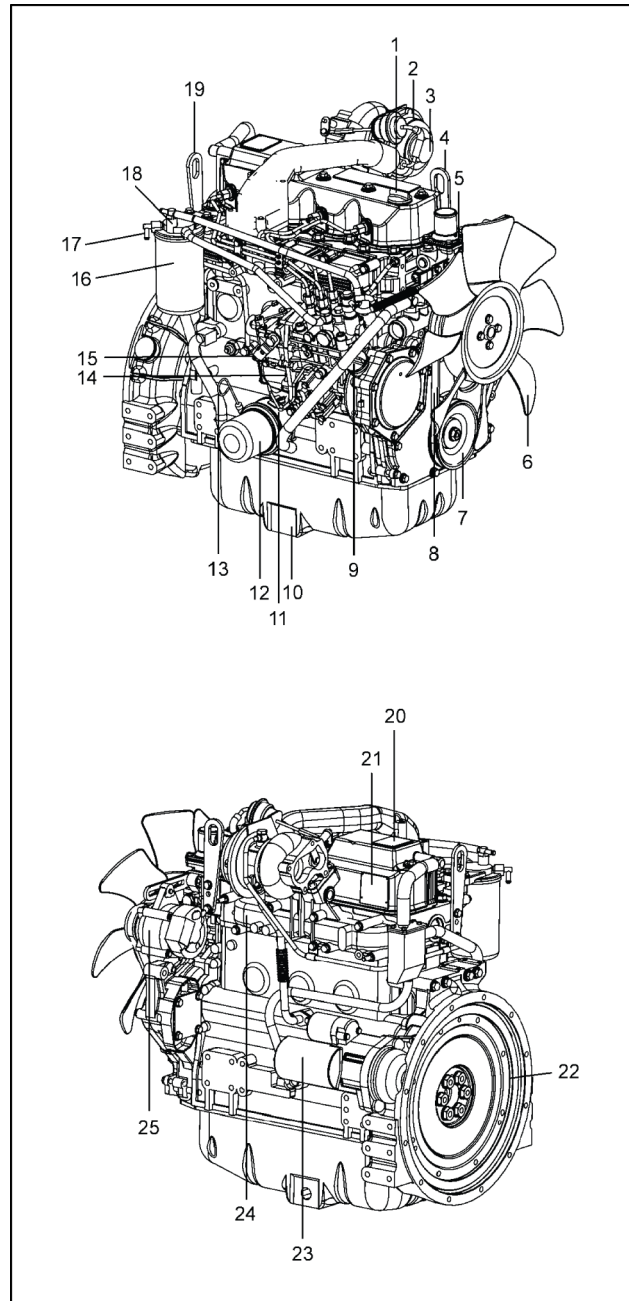

TUL12EXN4782CA 1

NOTE: This illustration shows the 4TNV98T engine (with turbocharger).

The drain plug (engine oil) location depends on the engine installed on the machine unit to be on the fuel injection pump side (above illustration) or starter motor side.

Engine - Static description

1. Emission reduction

New fuel injection pressure

- Mono plunger
- Higher injection pressure
- Injection timing, speed timer, load timer, cold start timer control

2. Noise reduction

Higher stiffness cylinder block

Higher stiffness gear-case

3. Emission reduction

Injection nozzle

- Low suck volume
- Multi injection holes

4. Emission reduction

Cylinder head

- Optimal nozzle angle
- Optimal swirl ratio
- Optional valve timing

5. Emission reduction

Piston

- New combustion chamber

Noise reduction

New lube oil pan

- Change rotor shape for low pulsation
- Driven by crankshaft directly

6. Emission reduction

Cylinder head

- 4 valve/cylinder (intake-2, exhaust-2)
- Optimal installation of the injection nozzle vertical installation and location of the centre of cylinder
- Optimal valve timing

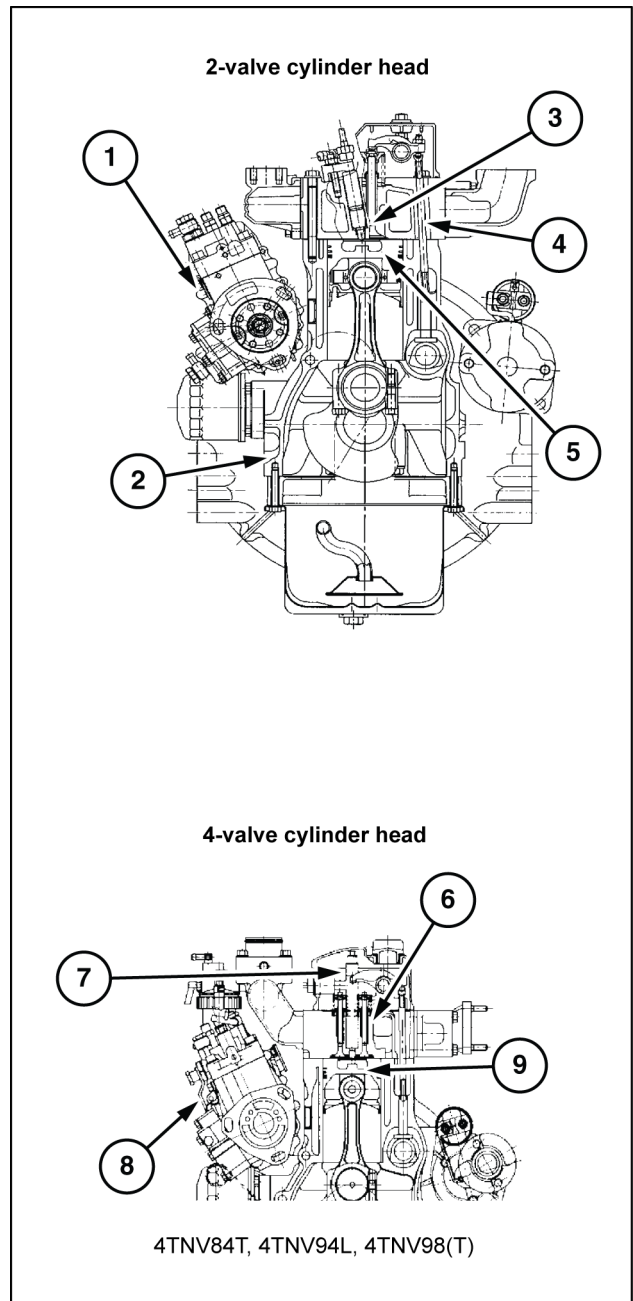

TUL12EXN4783CB 1

7. Emission reduction

New fuel injection nozzle

- Low suck volume
- Multi injection holes

8. Emission reduction

New fuel injection pump

- Mono plunger
- Higher injection pressure
- Mechanical control of injection timing, speed timer, load timer, cold start timer

9. Emission reduction

Piston

- New combustion chamber

Noise reduction (only applied for 4TNV84T)

New lube oil pan

- Change rotor shape for low pulsation
- Driven by crankshaft directly

Engine - Service instruction

Periodic maintenance schedule

The engine periodic inspection timing is hard to determine as it varies with the application, load status, qualities of the fuel and lubricating oils used and handling status. General rules are described here.

- : User-maintenance
- : Parts replacement
- : Shop-inspection

Classification	Piece	Daily	Maintenance period				
			Every 50 h	Every 250 h or 3 months	Every 500 h or 6 months	Inspection every 1000 h or one year	Every 2000 h or two years
Whole	Visual check around the machine	○					
Fuel system	Fuel tank level check and fuel supply	○					
	Fuel tank drain		○				
	Water separator (Option) draining	○					
	Fuel system bleeding		○				
	Water separator cleaning			○			
	Fuel filter element replacement					■	
Lubricating oil system	Lube oil level check and replenishment	○					
	Lube oil replacement						
	Lube oil filter replacement		■ 1st time	■ 2nd time and thereafter			
Coolant pump	Coolant level check and replenishment	○					
	Radiator fin cleaning			○			
	V-belt tension check		○ 1st time	○ 2nd time and thereafter			
	Coolant change					■	
	Coolant/water path flushing and maintenance						●
Rubber hose	Fuel pipe and coolant pipe inspection and maintenance	○					●
Injection governor	Inspection and adjustment of governor lever and accelerator	○		○			

Engine - Engine and crankcase

Classification	Piece	Daily	Maintenance period				
			Every 50 h	Every 250 h or 3 months	Every 500 h or 6 months	Inspection every 1000 h or one year	Every 2000 h or two years
Air intake system	Air cleaner cleaning and element replacement			○	■		
	Diaphragm assy inspection					● (2 years)	
	Turbocharger blower cleaning*					●*	
Electrical system	Warning lamp and instruments function check	○					
	Battery electrolyte level check and battery recharging		○				
Cylinder head	Intake/exhaust valve head clearance adjustment					●	
	Intake/exhaust valve seat lapping						●
Fuel injection pump and nozzle	Fuel injection nozzle pressure inspection					●*	
	Fuel injection timing adjustment Fuel injection pump inspection and adjustment						●*

*EPA allows servicing the emission related parts every 1500 - 3000 h



Suggest:

If the above button click is invalid.

Please download this document

first, and then click the above link

to download the complete manual.

Thank you so much for reading

Engine - Inspect - Daily Inspection

Be sure to check the following points before starting an engine every day:

No.	Inspection item
1.	Visual check around the machine
2.	Fuel tank level check and fuel supply
3.	Lube oil level check and replenishment
4.	Coolant level check and replenishment
5.	Fuel pipe and coolant pipe inspection and maintenance
6.	Inspection and adjustment of governor lever and accelerator
7.	Warning lamp and instruments function check
8.	Water separator draining

Visual check around the machine

If any problem is found, do not use before the engine repairs have been completed.

- Oil leak from the lubrication system
- Fuel leak from the fuel system
- Coolant leak from the water cooling system
- Damaged parts
- Loosened or lost screws
- Fuel, radiator rubber hoses, cracked V-belt, loosened clamp

Fuel tank level check and fuel supply

Check the remaining fuel oil level in the fuel tank and refuel the recommended fuel if necessary.

<https://www.ebooklibonline.com>

Hello dear friend!

Thank you very much for reading.

Enter the link into your browser.

The full manual is available for immediate download.

<https://www.ebooklibonline.com>