

SERVICE MANUAL

**CX7080 Elevation / CX7090 Elevation / CX8070 Elevation
CX8080 Elevation / CX8090 Elevation
CR8070 / CR8080 / CR9070 / CR9080 / CR9090
Combine**

Part number 47612507

English
March 2014



SERVICE MANUAL



CR7090 Cursor 9 Tier IVa , CR8070 Combine Tier IV engine MY14 [1940 -] , CR8070 , CR8080 MY14 CR with tracks [1940 -] , CR8080 MY14 combine [1940 -] , CR8080 , CR8090 Cursor 10 Tier IVa , CR8090 Cursor 10 Tier IVa , CR9070 MY14 Combine with tracks [1940 -] , CR9070 MY14 combine [1940 -] , CR9080 MY14 combine [1940 -] , CR9080 MY14 combine with tracks [1940 -] , CR9080 , CR9090 Cursor 13 Tier IVa , CR9090 Cursor 13 Tier IVa , CR9090 MY14 ZED built combine for NA [1940 -] , CR9090 MY14 combine [1940 -] , CR9090 MY14 combine with tracks [1940 -] , CX7080 Elevation , CX7090 Elevation , CX8070 Elevation , CX8080 Elevation , CX8090 Elevation

Link Product / Engine

Product	Market Product	Engine
CR9080 [1779 -]	International Region	F3BE0684N*E916
CR9080 [Y9G113001 - YAG113831]	North America	F3BE0684N*E916
CR9080 [YAG113901 -]	North America	F3BE0684N*E916
CR9080 [Y8G112001 - Y9G112788]	North America	F3BE0684N*E916
CR9080 [1779 -]	Latin America	F3BE0684N*E916

<https://www.ebooklibonline.com>

Hello dear friend!

Thank you very much for reading.

Enter the link into your browser.

The full manual is available for immediate download.

<https://www.ebooklibonline.com>

Contents

INTRODUCTION

Engine	10
[10.001] Engine and crankcase	10.1
[10.254] Intake and exhaust manifolds and muffler	10.2
[10.500] Selective Catalytic Reduction (SCR) exhaust treatment	10.3
[10.400] Engine cooling system	10.4
[10.418] Rotary screen	10.5
[10.450] Engine air compressor	10.6
Main gearbox and drive	14
[14.100] Main gearbox and drive	14.1
Transmission	21
[21.114] Mechanical transmission	21.1
[21.130] Mechanical transmission external controls.....	21.2
[21.145] Gearbox internal components.....	21.3
[21.182] Differential.....	21.4
Front axle system	25
[25.108] Final drive hub, steering knuckles, and shafts	25.1
[25.310] Final drives	25.2
Rear axle system	27
[27.124] Final drive hub, steering knuckles, and shafts	27.1
Hydrostatic drive	29
[29.100] Transmission and steering hydrostatic control	29.1
[29.204] Reservoir, cooler, and lines	29.2
[29.218] Pump and motor components.....	29.3
[29.202] Hydrostatic transmission	29.4
[29.300] Rear hydrostatic transmission.....	29.5

Brakes and controls	33
[33.202] Hydraulic service brakes	33.1
[33.110] Parking brake or parking lock	33.2
Hydraulic systems	35
[35.000] Hydraulic systems.....	35.1
[35.300] Reservoir, cooler, and filters.....	35.2
[35.106] Variable displacement pump	35.3
[35.102] Pump control valves.....	35.4
[35.359] Main control valve.....	35.5
[35.322] Regulated/Low pressure system	35.6
[35.220] Auxiliary hydraulic pump and lines	35.7
[35.410] Header or attachment height system	35.8
[35.602] Header or attachment leveling system	35.9
[35.760] Header reverser drive	35.10
[35.992] Stone trapping system	35.11
[35.994] Positive Straw Discharge (PSD)	35.12
[35.796] Chaff spreader control	35.13
[35.440] Grain tank unload system	35.14
[35.450] Traction variator system.....	35.15
Steering	41
[41.101] Steering control	41.1
[41.200] Hydraulic control components.....	41.2
[41.432] Autoguidance steering	41.3
Tracks and track suspension	48
[48.138] Track rollers	48.1
[48.130] Track frame and driving wheels	48.2
[48.134] Track tension units	48.3
[48.100] Tracks	48.4

Cab climate control	50
[50.100] Heating	50.1
[50.104] Ventilation	50.2
[50.200] Air conditioning	50.3
Electrical systems	55
[55.000] Electrical system	55.1
[55.100] Harnesses and connectors	55.2
[55.201] Engine starting system	55.3
[55.301] Alternator	55.4
[55.988] Selective Catalytic Reduction (SCR) electrical system	55.5
[55.640] Electronic modules	55.6
[55.029] Gearbox electric system	55.7
[55.019] Hydrostatic drive control system	55.8
[55.512] Cab controls	55.9
[55.051] Cab Heating, Ventilation, and Air-Conditioning (HVAC) controls	55.10
[55.050] Heating, Ventilation, and Air-Conditioning (HVAC) control system	55.11
[55.662] Header height control	55.12
[55.628] Threshing electrical control	55.13
[55.427] Straw walker variator	55.14
[55.426] Harvest material flow control system	55.15
[55.624] Residue handling control	55.16
[55.785] Precision farming system	55.17
[55.911] Global Positioning System (GPS)	55.18
[55.680] Autopilot/Autoguidance	55.19
[55.518] Wiper and washer system	55.20
[55.404] External lighting	55.21
[55.405] External lighting switches and relays	55.22
[55.514] Cab lighting	55.23

[55.408] Warning indicators, alarms, and instruments	55.24
[55.DTC] FAULT CODES	55.25
Attachments/Headers	58
[58.900] Belt feeding	58.1
Product feeding	60
[60.105] Floating roll, feed chain, and drive	60.1
[60.110] Feeder housing	60.2
[60.150] Feeder drive system	60.3
[60.165] Feeder reverse system	60.4
[60.112] Stone trapping system	60.5
[60.260] Rotor	60.6
Threshing	66
[66.000] Threshing	66.1
[66.260] Threshing mechanism drive system	66.2
[66.331] Rotor	66.3
[66.330] Drum	66.4
[66.360] Drum/Rotor housing	66.5
[66.321] Drum/Rotor variator with electrical control	66.6
[66.105] Concave	66.7
[66.101] Concave conveyor plate	66.8
[66.110] Concave control system	66.9
Separation	72
[72.350] Beater	72.1
[72.220] Discharge beater	72.2
[72.420] Rotary separator	72.3
[72.440] Straw-flow beater	72.4
[72.110] Straw walker drive system	72.5
[72.101] Straw walkers and shafts	72.6

Residue handling	73
[73.300] Positive Straw Discharge (PSD)	73.1
[73.230] Straw chopper.....	73.2
[73.210] Straw chopper drive system.....	73.3
[73.220] Straw chopper frame	73.4
[73.335] Chaff spreader	73.5
[73.410] Opti-Spread™ system.....	73.6
Cleaning	74
[74.000] Cleaning.....	74.1
[74.101] Cleaning drive systems	74.2
[74.110] Grain pan.....	74.3
[74.114] Upper shaker shoe	74.4
[74.118] Lower shaker shoe	74.5
[74.125] Clean grain and return cross auger housing	74.6
[74.130] Fan housing	74.7
[74.136] Fan drive system	74.8
[74.140] Tailings return system	74.9
Crop storage / Unloading	80
[80.101] Clean grain elevator.....	80.1
[80.150] Grain tank	80.2
[80.175] Grain tank unload drive system	80.3
[80.180] Grain tank unload	80.4
Accessories	88
[88.100] Accessories	88.1
Platform, cab, bodywork, and decals	90
[90.154] Cab doors and hatches	90.1
[90.110] Operator platform less cab	90.2
[90.118] Protections and footboards.....	90.3

[90.124] Pneumatically-adjusted operator seat..... 90.4
[90.105] Machine shields and guards 90.5



INTRODUCTION

Foreword

CR Series Tier IV	WE ---
CR8070 [1779 -]	
CR8080 [1779 -]	
CR9080 [1779 -]	
CX7000 Elevation series	WE
CX8000 Elevation series	WE

IMPORTANT INFORMATION

All repair and maintenance works listed in this manual must be carried out only by staff belonging to the NEW HOLLAND Service network, strictly complying with the instructions given and using, whenever required, the special tools.

Anyone who carries out the above operations without complying with the prescriptions shall be responsible for the subsequent damages.

The manufacturer and all the organizations of its distribution chain, including - without limitation - national, regional or local dealers, reject any responsibility for damages due to the anomalous behavior of parts and/or components not approved by the manufacturer himself, including those used for the servicing or repair of the product manufactured or marketed by the Manufacturer. In any case, no warranty is given or attributed on the product manufactured or marketed by the Manufacturer in case of damages due to an anomalous behavior of parts and/or components not approved by the Manufacturer.

No reproduction, though partial of text and illustrations allowed

Basic instructions - How to use and navigate through this manual

CR Series Tier IV	WE ---
CR8070 [1779 -]	
CR8080 [1779 -]	
CR9080 [1779 -]	
CX7000 Elevation series	WE
CX8000 Elevation series	WE

Technical Information

This manual has been produced by a new technical information system. This new system is designed to deliver technical information electronically through Web delivery (eTim), DVD and in paper manuals. A coding system called SAP has been developed to link the technical information to other Product Support functions, e.g., Warranty.

Technical information is written to support the maintenance and service of the functions or systems on a customer's machine. When a customer has a concern on his machine it is usually because a function or system on his machine is not working at all, is not working efficiently, or is not responding correctly to his commands. When you refer to the technical information in this manual to resolve that customer's concern, you will find all the information classified using the SAP coding, according to the functions or systems on that machine. Once you have located the technical information for that function or system then you will find all the mechanical, electrical or hydraulic devices, components, assemblies and sub assemblies for that function or system. You will also find all the types of information that have been written for that function or system, the technical data (specifications), the functional data (how it works), the diagnostic data (fault codes and troubleshooting) and the service data (remove, install adjust, etc.).

By integrating SAP coding into technical information, you will be able to search and retrieve just the right piece of technical information you need to resolve that customer's concern on his machine. This is made possible by attaching 3 categories to each piece of technical information during the authoring process.

The first category is the Location, the second category is the Information Type and the third category is the Product:

- LOCATION - is the component or function on the machine, that the piece of technical information is going to describe e.g. Fuel tank.
- INFORMATION TYPE - is the piece of technical information that has been written for a particular component or function on the machine e.g. Capacity would be a type of Technical Data that would describe the amount of fuel held by the Fuel tank.
- PRODUCT - is the model for which the piece of technical information is written.

Every piece of technical information will have those 3 categories attached to it. You will be able to use any combination of those categories to find the right piece of technical information you need to resolve that customer's concern on his machine.

That information could be:

- the description of how to remove the cylinder head
- a table of specifications for a hydraulic pump
- a fault code
- a troubleshooting table
- a special tool

How to use this manual

This manual is divided into Sections. Each Section is then divided into Chapters. Contents pages are included at the beginning of the manual, then inside every Section and inside every Chapter. An alphabetical Index is included at the end of a Chapter. Page number references are included for every piece of technical information listed in the Chapter Contents or Chapter Index.

Each Chapter is divided into four Information types:

- Technical Data (specifications) for all the mechanical, electrical or hydraulic devices, components and assemblies.
- Functional Data (how it works) for all the mechanical, electrical or hydraulic devices, components and assemblies.
- Diagnostic Data (fault codes, electrical and hydraulic troubleshooting) for all the mechanical, electrical or hydraulic devices, components and assemblies.
- Service Data (remove disassembly, assemble, install) for all the mechanical, electrical or hydraulic devices, components and assemblies.

Sections

Sections are grouped according to the main functions or a systems on the machine. Each Section is identified by a number 00, 35, 55, etc. The amount of Sections included in the manual will depend on the type and function of the machine that the manual is written for. Each Section has a Contents page listed in alphabetic/numeric order. This table illustrates which Sections could be included in a manual for a particular product.

SECTION	PRODUCT				
	Tractors				
	Vehicles with working arms: backhoes, excavators, skid steers,				
	Combines, forage harvesters, balers,				
	Seeding, planting, floating, spraying equipment,				
					Mounted equipment and tools,
00 - Maintenance					
05 - Machine completion and equipment					
10 - Engine					
14 - Main gearbox and drive					
18 - Clutch					
21 - Transmission					
23 - Four wheel drive system					
25 - Front axle system					
27 - Rear axle system					
29 - Hydrostatic drive					
31 - Implement power take-off					
33 - Brakes and controls					
35 - Hydraulic systems					
36 - Pneumatic system					
37 - Hitches, drawbars and implement couplings					
39 - Frames and ballasting					
41 - Steering					
44 - Wheels					
46 - Steering clutches					
48 - Tracks and track suspension					
50 - Cab climate control					
55 - Electrical systems					
56 - Grape harvester shaking					
58 - Attachments/headers					
60 - Product feeding					
61 - Metering system					
62 - Pressing - Bale formation					

INTRODUCTION

63 - Chemical applicators						
64 - Chopping						
66 - Threshing						
68 - Tying/Wrapping/Twisting						
69 - Bale wagons						
70 - Ejection						
71 - Lubrication system						
72 - Separation						
73 - Residue handling						
74 - Cleaning						
75 - Soil preparation/Finishing						
76 - Secondary cleaning / Destemmer						
77 - Seeding						
78 - Spraying						
79 - Planting						
80 - Crop storage / Unloading						
82 - Front loader and bucket						
83 - Telescopic single arm						
84 - Booms, dippers and buckets						
86 - Dozer blade and arm						
88 - Accessories						
89 - Tools						
90 - Platform, cab, bodywork and decals						

Safety rules

CR Series Tier IV	WE ---
CR series Tier III	
CX7000 Elevation series	WE
CX8000 Elevation series	WE

PRECAUTIONARY STATEMENTS

Personal Safety



This is the safety alert symbol. It is used to alert you to potential personal injury hazards. Obey all safety messages that follow this symbol to avoid possible injury or death.

Throughout this manual and on machine decals, you will find precautionary statements ("DANGER", "WARNING", and "CAUTION") followed by specific instructions. These precautions are intended for the personal safety of you and those working with you. Please take the time to read them.



DANGER

DANGER indicates a hazardous situation which, if not avoided, will result in death or serious injury. The color associated with Danger is RED.

M1169A



WARNING

WARNING indicates a hazardous situation which, if not avoided, could result in death or serious injury. The color associated with Warning is ORANGE.

M1170A



CAUTION

CAUTION, used with the safety alert symbol, indicates a hazardous situation which, if not avoided, could result in minor or moderate injury. The color associated with Caution is YELLOW.

M1171A

FAILURE TO FOLLOW "DANGER", "WARNING", AND "CAUTION" INSTRUCTIONS MAY RESULT IN SERIOUS BODILY INJURY, DAMAGE TO HEALTH OR DEATH.

NOTICE: Install new decals if the old decals are destroyed, lost painted over or cannot be read. When parts are replaced that have decals make sure you install a new decal with each new part.

MACHINE SAFETY

NOTICE: The word "notice" is used to inform the reader of something they need to know to prevent minor machine damage if a certain procedure is not followed.

The precautionary statements ("Important") is followed by specific instructions. This statement is intended for machine safety.

INFORMATION

NOTE: Instructions used to identify and present supplementary information.

LEGAL OBLIGATIONS

This machine may be equipped with special guarding or other devices in compliance with local legislation. Some of these require active use by the operator. Therefore, check local legislations on the usage of this machine.

SERVICE MANUAL

Engine



CR7090 Cursor 9 Tier IVa , CR8070 Combine Tier IV engine MY14 [1940 -] , CR8070 , CR8080 MY14 CR with tracks [1940 -] , CR8080 MY14 combine [1940 -] , CR8080 , CR8090 Cursor 10 Tier IVa , CR8090 Cursor 10 Tier IVa , CR9070 MY14 Combine with tracks [1940 -] , CR9070 MY14 combine [1940 -] , CR9080 MY14 combine [1940 -] , CR9080 MY14 combine with tracks [1940 -] , CR9080 , CR9090 Cursor 13 Tier IVa , CR9090 Cursor 13 Tier IVa , CR9090 MY14 ZED built combine for NA [1940 -] , CR9090 MY14 combine [1940 -] , CR9090 MY14 combine with tracks [1940 -] , CX7080 Elevation , CX7090 Elevation , CX8070 Elevation , CX8080 Elevation , CX8090 Elevation



Suggest:

If the above button click is invalid.

Please download this document

first, and then click the above link

to download the complete manual.

Thank you so much for reading

Engine - Remove

CR Series Tier IV	WE ---
CR8070 [1779 -]	
CX7000 Elevation series	WE
CX8000 Elevation series	WE

NOTE: The engine and cooling system used in the combine is designed to be removed as a modular unit. The following engine removal procedure demonstrates the removal of the engine only from the module. This procedure takes into consideration the possible unavailability of proper, or sufficient lifting equipment for complete module removal. When possible, remove the engine and cooling system module as designed.

1. Remove the gearbox and hydraulic pumps from the engine. (Refer to **Main gearbox and drive - Remove (14.100)**)
Place a suitable container (1) below the coolant drain hose (2).

NOTE: Depending on model, the cooling system has a coolant capacity between **50 - 60 l (13.2 - 15.9 US gal)**. Be sure to use clean containers with adequate capacity when draining the cooling system.

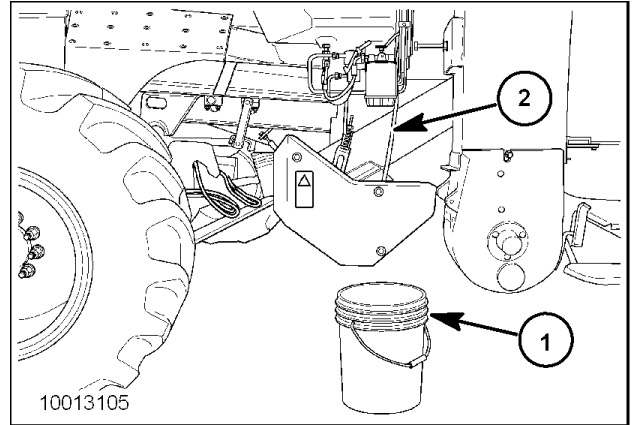

10013105_780 1

2. Refer to **Expansion tank - Remove (10.400)** for the coolant fluid drain and removal of the engine coolant reservoir.

NOTE: Depending on the model, the combine engine has an oil capacity between **29 - 35 l (7.7 - 9.2 US gal)**. Be sure to use clean containers with adequate capacity when draining the engine oil.

3. Remove the cap (1) and turn the engine oil drain valve (2), to the open position. Drain all of the engine oil into suitable containers.

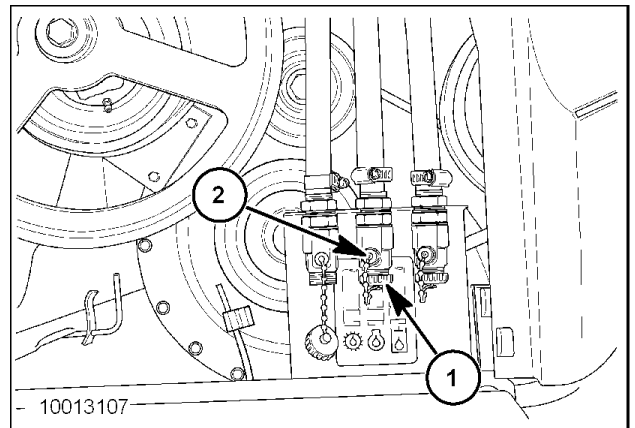

10013107 2

4. Loosen and remove the mounting hardware from the protection cover (1).
Remove the cover (1) from the engine compartment.

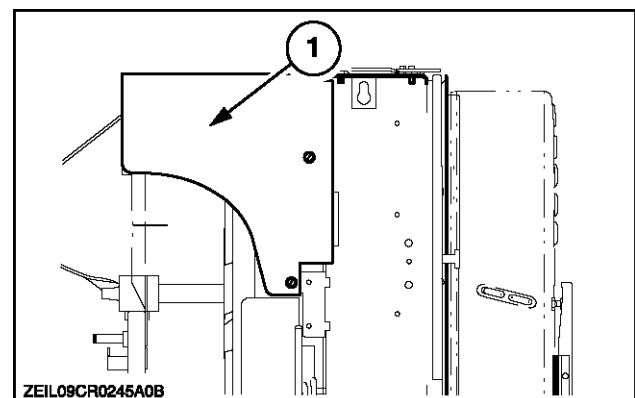

ZEIL09CR0245A0B 3

<https://www.ebooklibonline.com>

Hello dear friend!

Thank you very much for reading.

Enter the link into your browser.

The full manual is available for immediate download.

<https://www.ebooklibonline.com>