

A8800 MR
Cane Harvester
from PIN PRCY8800VFPA02199

SERVICE MANUAL

Part number 47485957

English

September 2015

© 2015 CNH industrial Latin America LTDA. All Rights Reserved.





SERVICE MANUAL

8800 Multi row [PRCY8800VFPA02199 -]

Contents

INTRODUCTION

Engine.....	10
[10.001] Engine and crankcase	10.1
[10.103] Crankshaft and flywheel.....	10.2
[10.106] Valve drive and gears	10.3
[10.206] Fuel filters	10.4
[10.250] Turbocharger and lines.....	10.5
[10.218] Fuel injection system.....	10.6
[10.254] Intake and exhaust manifolds and muffler	10.7
[10.414] Fan and drive	10.8
[10.400] Engine cooling system	10.9
[10.450] Engine air compressor	10.10
Transmission.....	21
[21.900] Hydraulic pump drive.....	21.1
Front axle system	25
[25.122] Axle suspension control.....	25.1
Rear axle system.....	27
[27.120] Planetary and final drives	27.1
Hydrostatic drive.....	29
[29.202] Hydrostatic transmission	29.1
Brakes and controls	33
[33.110] Parking brake or parking lock	33.1
[33.202] Hydraulic service brakes	33.2
Hydraulic systems.....	35
[35.000] Hydraulic systems.....	35.1
[35.105] Charge pump.....	35.2

<https://www.ebooklibonline.com>

Hello dear friend!

Thank you very much for reading.

Enter the link into your browser.

The full manual is available for immediate download.

<https://www.ebooklibonline.com>

[35.300] Reservoir, cooler, and filters.....	35.3
[35.310] Distributor and lines.....	35.4
[35.600] High flow hydraulics.....	35.5
[35.820] Hydraulic driven cooling fans.....	35.6
Tracks and track suspension.....	48
[48.110] Front suspension.....	48.1
[48.130] Track frame and driving wheels.....	48.2
[48.100] Tracks.....	48.3
[48.138] Track rollers.....	48.4
Cab climate control.....	50
[50.200] Air conditioning.....	50.1
Electrical systems.....	55
[55.100] Harnesses and connectors.....	55.1
[55.000] Electrical system.....	55.2
[55.024] Transmission control system.....	55.3
[55.405] External lighting switches and relays.....	55.4
[55.513] Cab transmission controls.....	55.5
[55.514] Cab lighting.....	55.6
[55.051] Cab Heating, Ventilation, and Air-Conditioning (HVAC) controls.....	55.7
[55.518] Wiper and washer system.....	55.8
[55.036] Hydraulic system control.....	55.9
[55.820] Chopping and cutting control systems.....	55.10
Attachments/Headers.....	58
[58.130] Attachment/Header frame.....	58.1
Product feeding.....	60
[60.370] Basecutter.....	60.1
[60.340] Topper.....	60.2
[60.110] Feeder housing.....	60.3

[60.350] Crop divider	60.4
[60.380] Butt lifter roller	60.5
[60.360] Knock-down rollers	60.6
[60.390] Conveyor roller train	60.7
Chopping	64
[64.000] Chopping	64.1
[64.106] Drum	64.2
[64.130] Drum gearbox	64.3
[64.160] Crop processor	64.4
Cleaning	74
[74.200] Upper extractors	74.1
[74.130] Fan housing	74.2
[74.204] Lower extractors	74.3



INTRODUCTION

Safety rules

8800

Personal safety





This is the safety alert symbol. It is used to alert you to potential personal injury hazards. Obey all safety messages that follow this symbol to avoid possible death or injury.

Throughout this manual you will find the signal words DANGER, WARNING, and CAUTION followed by special instructions. These precautions are intended for the personal safety of you and those working with you.

Read and understand all the safety messages in this manual before you operate or service the machine.

 DANGER indicates a hazardous situation that, if not avoided, will result in death or serious injury.

 WARNING indicates a hazardous situation that, if not avoided, could result in death or serious injury.

 CAUTION indicates a hazardous situation that, if not avoided, could result in minor or moderate injury.

FAILURE TO FOLLOW DANGER, WARNING, AND CAUTION MESSAGES COULD RESULT IN DEATH OR SERIOUS INJURY.

Machine safety

NOTICE: Notice indicates a situation that, if not avoided, could result in machine or property damage.

Throughout this manual you will find the signal word Notice followed by special instructions to prevent machine or property damage. The word Notice is used to address practices not related to personal safety.

Information

NOTE: Note indicates additional information that clarifies steps, procedures, or other information in this manual.

Throughout this manual you will find the word Note followed by additional information about a step, procedure, or other information in the manual. The word Note is not intended to address personal safety or property damage.

Safety rules - Ecology and the environment

Soil, air, and water quality is important for all industries and life in general. When legislation does not yet rule the treatment of some of the substances that advanced technology requires, sound judgment should govern the use and disposal of products of a chemical and petrochemical nature.

Familiarize yourself with the relative legislation applicable to your country, and make sure that you understand this legislation. Where no legislation exists, obtain information from suppliers of oils, filters, batteries, fuels, anti-freeze, cleaning agents, etc., with regard to the effect of these substances on man and nature and how to safely store, use, and dispose of these substances.

Helpful hints

- Avoid the use of cans or other inappropriate pressurized fuel delivery systems to fill tanks. Such delivery systems may cause considerable spillage.
- In general, avoid skin contact with all fuels, oils, acids, solvents, etc. Most of these products contain substances that may be harmful to your health.
- Modern oils contain additives. Do not burn contaminated fuels and or waste oils in ordinary heating systems.
- Avoid spillage when you drain fluids such as used engine coolant mixtures, engine oil, hydraulic fluid, brake fluid, etc. Do not mix drained brake fluids or fuels with lubricants. Store all drained fluids safely until you can dispose of the fluids in a proper way that complies with all local legislation and available resources.
- Do not allow coolant mixtures to get into the soil. Collect and dispose of coolant mixtures properly.
- The air-conditioning system contains gases that should not be released into the atmosphere. Consult an air-conditioning specialist or use a special extractor to recharge the system properly.
- Repair any leaks or defects in the engine cooling system or hydraulic system immediately.
- Do not increase the pressure in a pressurized circuit as this may lead to a component failure.
- Protect hoses during welding. Penetrating weld splatter may burn a hole or weaken hoses, allowing the loss of oils, coolant, etc.

Battery recycling

Batteries and electric accumulators contain several substances that can have a harmful effect on the environment if the batteries are not properly recycled after use. Improper disposal of batteries can contaminate the soil, groundwater, and waterways. CASE IH strongly recommends that you return all used batteries to a CASE IH dealer, who will dispose of the used batteries or recycle the used batteries properly. In some countries, this is a legal requirement.



Mandatory battery recycling

NOTE: *The following requirements are mandatory in Brazil.*

Batteries are made of lead plates and a sulfuric acid solution. Because batteries contain heavy metals such as lead, CONAMA Resolution 401/2008 requires you to return all used batteries to the battery dealer when you replace any batteries. Do not dispose of batteries in your household garbage.

Points of sale are obliged to:

- Accept the return of your used batteries
- Store the returned batteries in a suitable location
- Send the returned batteries to the battery manufacturer for recycling

Basic instructions — Shop and assembly

Shimming

For each adjustment operation, select adjusting shims and measure the adjusting shims individually using a micrometer, then add up the recorded values. Do not rely on measuring the entire shimming set, which may be incorrect, or the rated value shown on each shim.

Rotating shaft seals

For correct rotating shaft seal installation, proceed as follows:

1. Before assembly, allow the seal to soak in the oil it will be sealing for at least thirty minutes.
2. Thoroughly clean the shaft and check that the working surface on the shaft is not damaged.
3. Position the sealing lip facing the fluid.

NOTE: *With hydrodynamic lips, take into consideration the shaft rotation direction and position the grooves so that they will move the fluid towards the inner side of the seal.*

4. Coat the sealing lip with a thin layer of lubricant (use oil rather than grease). Fill the gap between the sealing lip and the dust lip on double lip seals with grease.
5. Insert the seal in its seat and press down using a flat punch or seal installation tool. Do not tap the seal with a hammer or mallet.
6. While you insert the seal, check that the seal is perpendicular to the seat. When the seal settles, make sure that the seal makes contact with the thrust element, if required.
7. To prevent damage to the seal lip on the shaft, position a protective guard during installation operations.

O-ring seals

Lubricate the O-ring seals before you insert them in the seats. This will prevent the O-ring seals from overturning and twisting, which would jeopardize sealing efficiency.

Sealing compounds

Apply a sealing compound on the mating surfaces when specified by the procedure. Before you apply the sealing compound, prepare the surfaces as directed by the product container.

Spare parts

Only use CNH Original Parts or CASE IH Original Parts.

Only genuine spare parts guarantee the same quality, duration, and safety as original parts, as they are the same parts that are assembled during standard production. Only CNH Original Parts or CASE IH Original Parts can offer this guarantee.

When ordering spare parts, always provide the following information:

- Machine model (commercial name) and Product Identification Number (PIN)
- Part number of the ordered part, which can be found in the parts catalog



SERVICE MANUAL

Engine

8800 Multi row [PRCY8800VFPA02199 -]

Engine - General specification

Brand	FPT – Fiat PowerTrain Technologies
Series	Cursor 9
Number of rolls	6
Loop	Diesel, 4 stroke
Injection	Electronic, Common Rail
Aspiration	Intercooler turbo charger
Emissions	TIER 3 or TIER 0
Diameter	117 mm
Stroke	135 mm
Compression Ratio	16:1
Firing order	1-4-2-6-3-5
Engine speeds	
Idle speed	800 RPM
Nominal speed	2100 RPM
Total cylinder capacity	8710 cm³
Engine horse power	263 kW (358 Hp) or 243 kW (330 Hp) at 2100 RPM
Cold-engine valve clearance Intake / Exhaust	0.35 - 0.45 mm / 0.55 - 0.65 mm
Engine oil pressure	
Idle Speed	4 bar
Fast speed	5 bar
Maximum Engine Oil Temp	120 °C

NOTE: Do not put performance additives or other oil additives in the engine crankcase.

Engine - Special tools

NOTICE: The tools that appear below with the symbol “X” are essential for the operations described in this section. However, for greater safety and to obtain the best results as well as saving time and effort, it is recommended that these essential tools be used together with the specific tools listed below and certain tools that should be made according to the construction drawings given in this Manual.

List of specific tools needed to perform the different operations described in this Section.

- X **380000140** Compression Tool For Checking The Protrusion Of Cylinder Liners
- X **380000149** Rocker extractor
- X **380000150** Positioning tool for engine top dead center
- X **380000151** Adjustment tool for timing gear phonic wheel
- X **380000162** Bushing Guide
- X **380000363** Cylinder Liners Retainers
- X **380000366** Tool To Extract Cylinder Liners
- X **380000133** Valve Spring Compressor
- X **380040185** Wiring harness diagnostic and repair kit
- X **380040220** DPA-5 adapter kit without Case
- X **380200416** Tool to measure the engine compression
- 380000142** Spacers
- 380000364** Dial gauge base
- 380003005** Tool for removal and installation of the camshaft shell
- 380200298** Plate for alignment of the **Cursor®** 9 engine pulleys

Engine - Component localization

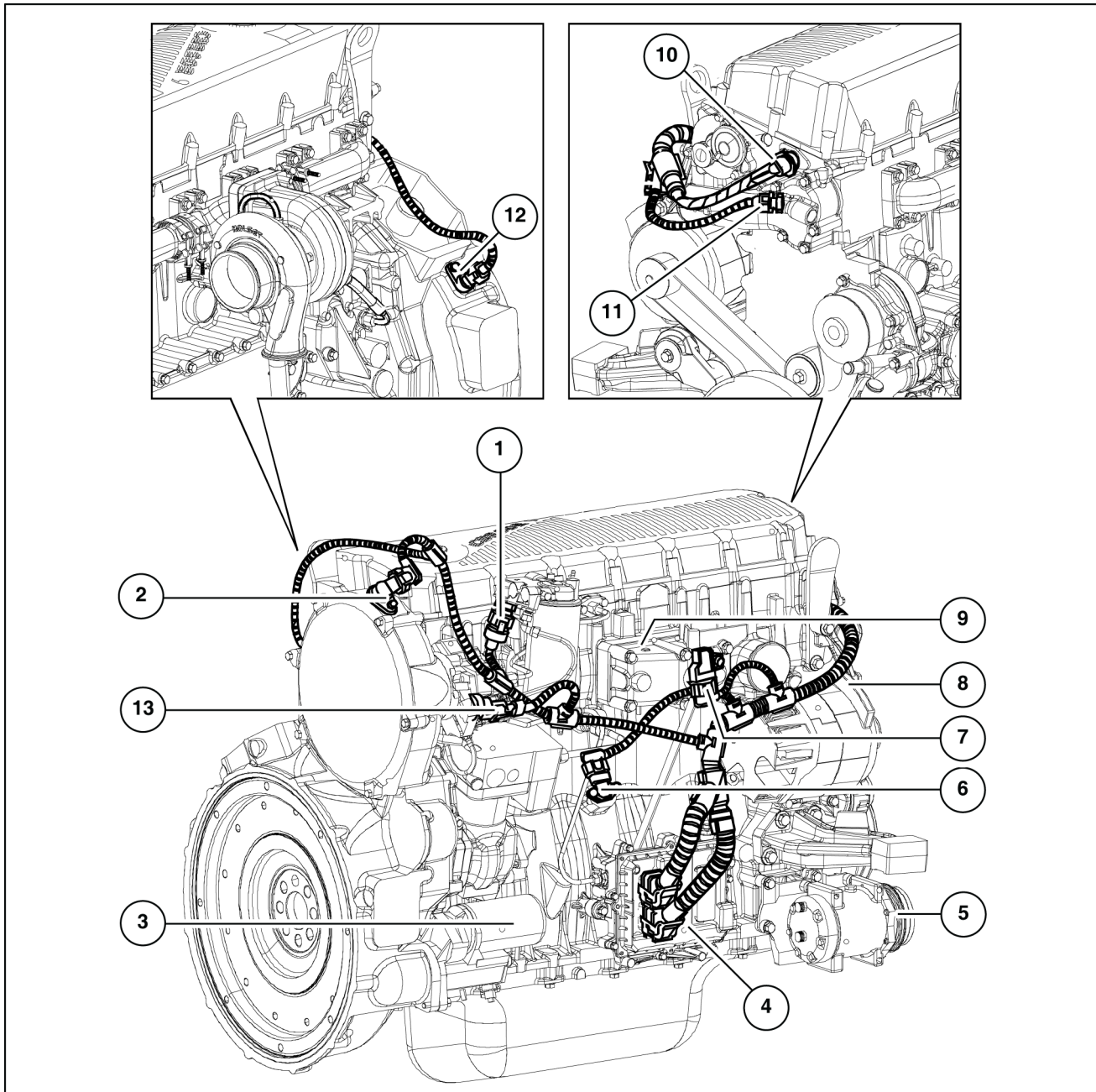

BRIL12SC0546G0A 1

Reference	Component	Reference	Component
(1)	Fuel temperature sensor	(8)	Alternator
(2)	Engine speed sensor in the camshaft	(9)	Cold start resistance
(3)	Starter Motor	(10)	Connector on the engine block for connection with the electro-injectors
(4)	Control unit EDC 7	(11)	Coolant temperature sensor
(5)	A/C compressor	(12)	Engine speed sensor in the engine flywheel
(6)	Pressure and temperature transducer	(13)	Fuel dosage valve in the high-pressure pump
(7)	Air temperature-pressure sensor	-	-

Engine - Remove

Method 1

1. Remove the screens from the top of the engine.
2. Disconnect the exhaust and the air filter from the engine.
3. Drain the coolant from the engine.
4. Remove the fan shaft from the engine and the tubing from the engine box.
5. Disconnect the electrical wiring, the pressure regulator cable, and the fuel lines from the engine.
6. Drain the engine oil and disconnect the draining line and the remote oil filter.
7. Support the pump gearbox and the pumps and disconnect the gearbox from the flywheel.
8. Remove the bolts that hold the engine assembly to the engine box.
9. Slide the engine on its mounting and, when it is free from the drive pump shaft, lift it to remove it from the engine box.

Make the necessary repairs and replace the motor, following the inverse procedure to that described above.

NOTE: When fixing the M16 bolts to support the engine (item 8), apply **LOCTITE® 262™** and a torque of **217 - 271 N·m (160.1 - 199.9 lb ft)**

Engine - Remove

Method 2

1. Remove the screens from the top of the engine.
2. Disconnect the exhaust and the air filter from the engine.
3. Drain the coolant from the engine and remove the radiator hoses from the engine.
4. Remove the fan shaft from the engine and the tubing from the engine box.
5. Disconnect the electrical wiring, the pressure regulator cable, the traction cables, and the fuel lines from the engine.
6. Drain the engine oil and disconnect the draining line and the remote oil filter.
7. Drain the oil from the pump housing and the line.
8. Isolate the hydraulic oil header tank (close the taps) and lower the oil level in the hydraulic tank to prevent loss.
9. Disconnect all of the suction pump hydraulic hoses.

NOTE: Block all of the hoses to prevent dirt from getting in.

10. Disconnect all of the hydraulic hoses from the pumps.

NOTE: Block all of the hoses to prevent dirt from getting in.

11. Remove the bolts that hold the engine assembly to the engine box.
12. Lift the engine and the gearbox assembly, removing them from the engine box.

Make the necessary repairs and replace the motor, following the inverse procedure to that described above.

Engine support and mounts - Install

Installation of the pads

1. Use lifting device no. **380000360** to install the engine in the machine and support it in the mounting bracket.

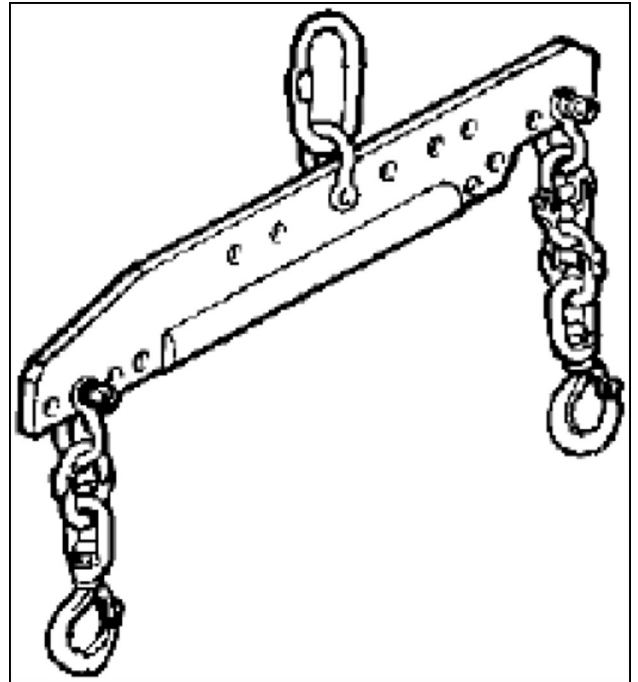

BRAG13CAALL014 1

2. Support the engine on rotary telescopic cradle No. 380000361.

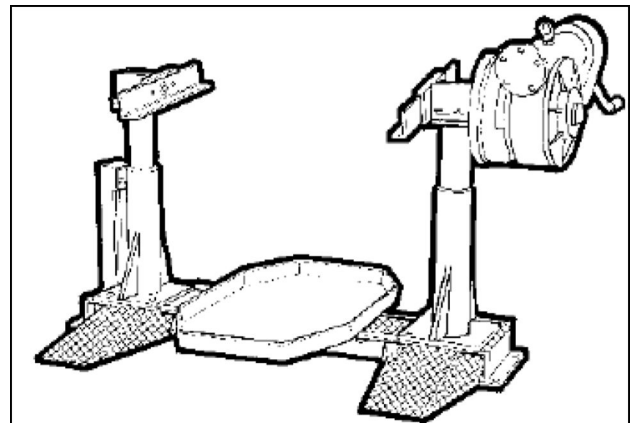

BRAG13CAALL015 2

3. Mount the front support brackets **(1)** and **(2)** of the engine pads.

Use M14 bolts. Torque: **200 N·m**.

(1) Front left-hand:

Located below the alternator.

(2) Front right-hand:

Located below the water pump.

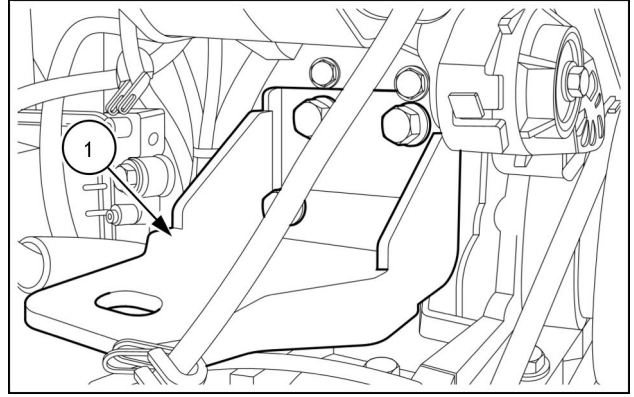

BRAG13CAALL001 3

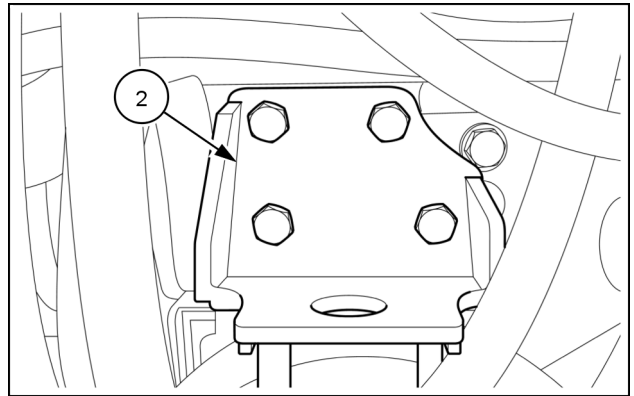

BRAG13CAALL002 4

4. Mount the rear support brackets **(3)** and **(4)** of the engine pads.

Use M16 bolts. Torque: **300 N·m**.

(3) Rear left-hand:

Located below the flywheel sensor.

(4) Rear right-hand:

Located next to the starter motor.

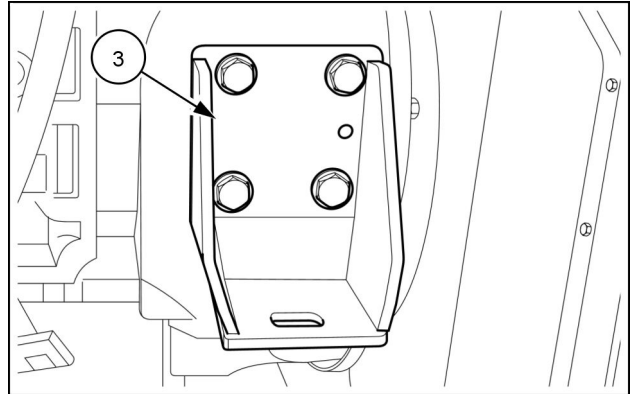

BRAG13CAALL003 5

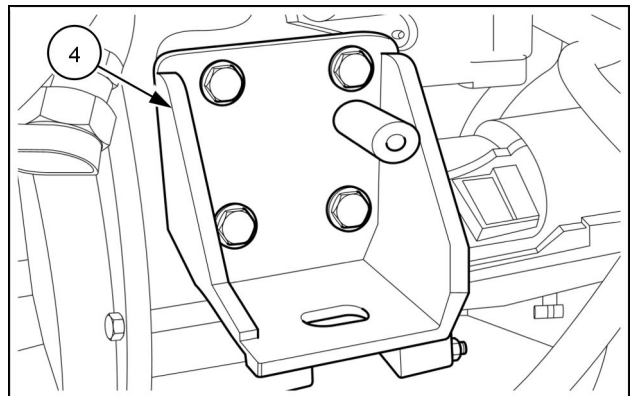

BRAG13CAALL004 6

NOTE: Use Loctite 262® to fix the screws in the brackets.



Suggest:

If the above button click is invalid.

Please download this document

first, and then click the above link

to download the complete manual.

Thank you so much for reading

5. Mount the pads on the engine housing. Start the assembly with the front left-hand pad **(1)**, located next to the engine's air-conditioning compressor.

NOTE: Use **LOCTITE® 262™** to fix the screws in the brackets. Torque: **110 N·m**

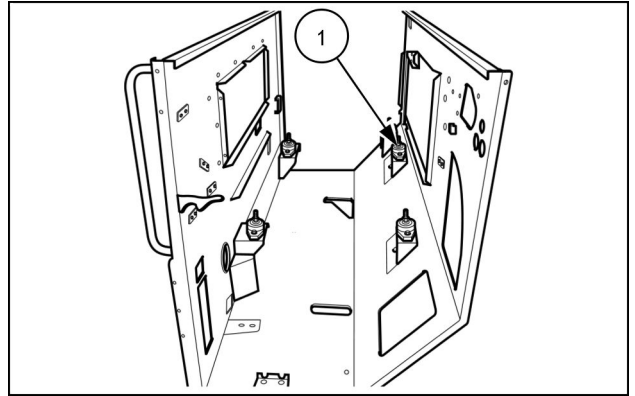

BRAG13CAALL005 7

6. The pad **(1)** must be fixed with its lateral face aligned with the edge of the bracket of the engine housing. Ensure that there is necessary clearance to the air-conditioning compressor.

ATTENTION: The other pads must remain loose on the engine housing. The final torque should be performed after the engine is installed.

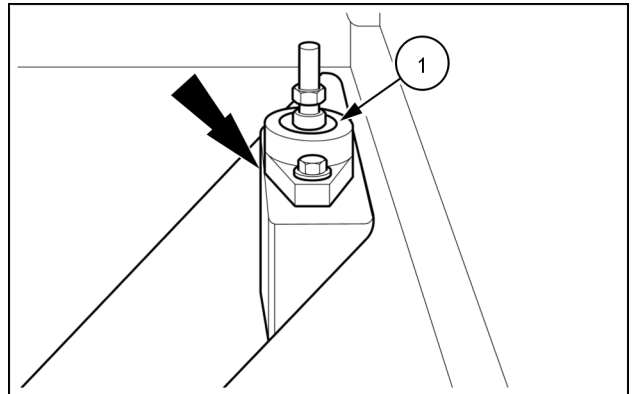

BRAG13CAALL006 8

7. The bottom nuts of the pads **(2)** must be fully screwed down. This will ensure the alignment and height of the engine.

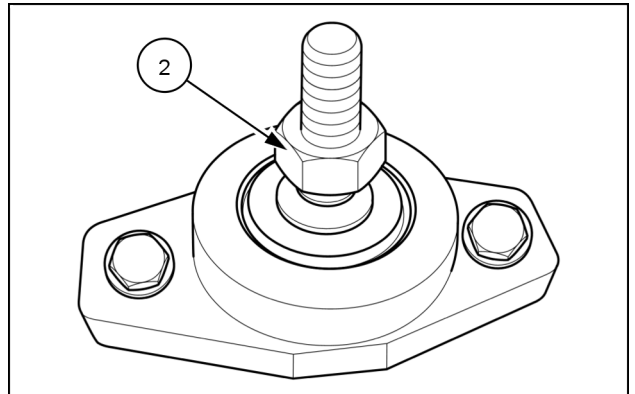

BRAG13CAALL007 9

<https://www.ebooklibonline.com>

Hello dear friend!

Thank you very much for reading.

Enter the link into your browser.

The full manual is available for immediate download.

<https://www.ebooklibonline.com>