

SERVICE MANUAL

**B90B / B90BLR / B100B / B100BLR / B100BTC
B110B / B110BTC / B115B**
Backhoe Loaders

Print No. 84428663B



INDEX

SECTION 00 - SAFETY RULES

FOREWORD.....	4
SAFETY INSTRUCTIONS.....	6
PREVENTION OF FIRE OR EXPLOSIONS.....	8
PREVENTION OF BURNS.....	9
PRECAUTIONS FOR WASTE DISPOSAL.....	10

SECTION 01 - MAINTENANCE

SECTION 02 - TECHNICAL SPECIFICATIONS

MODELS.....	3
IDENTIFICATION OF MAIN COMPONENTS.....	4
TECHNICAL SPECIFICATIONS.....	7
DIESEL ENGINE.....	7
TRANSMISSION.....	10
AXLES.....	11
BRAKES.....	11
STEERING.....	12
HYDRAULIC SYSTEM.....	12
FRONT COUNTERWEIGHT.....	13
NOISE AND VIBRATION LEVELS.....	13
BUCKETS.....	13
TYRES.....	14
DIMENSIONS AND PERFORMANCE.....	15
DIMENSIONS - 2WS SIDESHIFT.....	15
DIMENSIONS - 2WS CENTER PIVOT.....	16
DIMENSIONS - 2WS TC - SIDESHIFT.....	17
DIMENSIONS - 4WS SIDESHIFT.....	18
DIMENSIONS - 4WS CENTER PIVOT.....	19
LOADER ATTACHMENT PERFORMANCE.....	20
PERFORMANCE OF LOADER ATTACHMENT WITH FORKS.....	30
BACKHOE ATTACHMENT PERFORMANCE.....	35
BACKHOE ATTACHMENT LIFTING CAPACITY.....	55
MAXIMUM LIFTING LOADS.....	61
LOADER ATTACHMENT MAXIMUM LIFTING LOAD TABLE.....	61
BACKHOE ATTACHMENT MAXIMUM LIFTING LOAD TABLE.....	62
SUPPLY SUMMARY TABLE.....	63

SECTION 21 - TRANSMISSION

POWERSHUTTLE TRANSMISSION.....	3
TECHNICAL SPECIFICATIONS.....	4
HYDRAULIC DIAGRAM.....	7
CONTROLS.....	13
LUBRICATION.....	17
GREASING.....	20
REMOVAL FROM MACHINE.....	22
DISASSEMBLY AND ASSEMBLY.....	23
TROUBLESHOOTING.....	148
REPAIR TIMES.....	152
SPECIAL TOOLS.....	153
POWERSHIFT TRANSMISSION.....	154
TECHNICAL SPECIFICATIONS.....	154
CONTROLS.....	165
LUBRICATION.....	167
GREASING.....	169
REMOVAL FROM MACHINE.....	170
DISASSEMBLY AND ASSEMBLY.....	171
TROUBLESHOOTING.....	335
REPAIR TIMES.....	339
SPECIAL TOOLS.....	340

SECTION 25 - FRONT AXLES

2WD - 2WS FRONT AXLE.....	3
TECHNICAL SPECIFICATIONS.....	3
LUBRICATION AND GREASING.....	4
REMOVAL FROM MACHINE.....	6
DISASSEMBLY AND ASSEMBLY.....	7
TROUBLESHOOTING.....	7
4WD - 2WS FRONT AXLE.....	10
TECHNICAL SPECIFICATIONS.....	10
LUBRICATION AND GREASING.....	11
REMOVAL FROM MACHINE.....	13
DISASSEMBLY AND ASSEMBLY.....	14
TROUBLESHOOTING.....	57
SPECIAL TOOLS.....	61
4WS FRONT AXLE.....	62
TECHNICAL SPECIFICATIONS.....	62
LUBRICATION AND GREASING.....	63
REMOVAL FROM MACHINE.....	65
DISASSEMBLY AND ASSEMBLY.....	66
TROUBLESHOOTING.....	131
REPAIR TIMES.....	137
SPECIAL TOOLS.....	138

<https://www.ebooklibonline.com>

Hello dear friend!

Thank you very much for reading.

Enter the link into your browser.

The full manual is available for immediate download.

<https://www.ebooklibonline.com>

SECTION 27 - REAR AXLE

2WS REAR AXLE (B90B - B100B - B100BTC).....	3
TECHNICAL SPECIFICATIONS.....	3
LUBRICATION AND GREASING	5
REMOVAL FROM MACHINE	7
DISASSEMBLY AND ASSEMBLY.....	8
TROUBLESHOOTING.....	61
REPAIR TIMES.....	67
SPECIAL TOOLS.....	68
 2WS REAR AXLE (B110B - B110BTC).....	 69
TECHNICAL SPECIFICATIONS.....	69
LUBRICATION AND GREASING	71
REMOVAL FROM MACHINE	73
DISASSEMBLY AND ASSEMBLY.....	74
TROUBLESHOOTING.....	127
REPAIR TIMES.....	133
SPECIAL TOOLS.....	134
 4WS REAR AXLE (B115B).....	 135
TECHNICAL SPECIFICATIONS.....	135
LUBRICATION AND GREASING	138
REMOVAL FROM MACHINE	140
DISASSEMBLY AND ASSEMBLY.....	141
TROUBLESHOOTING.....	219
REPAIR TIMES.....	225
SPECIAL TOOLS.....	227

SECTION 33 - BRAKE SYSTEM

PARKING BRAKE.....	3
TECHNICAL SPECIFICATIONS.....	3
OPERATION.....	3
ADJUSTMENT.....	4
DISASSEMBLY AND ASSEMBLY.....	5
 SERVICE BRAKE	 14
TECHNICAL SPECIFICATIONS.....	14
OPERATION.....	14

SECTION 35 - HYDRAULIC SYSTEM

HYDRAULIC DIAGRAMS	3
HYDRAULIC DIAGRAM - 2WS SIDESHIFT MECHANICAL MODELS.....	3
HYDRAULIC DIAGRAM - 2WS SIDESHIFT PILOT MODELS	5
HYDRAULIC DIAGRAM - 2WS CENTER PIVOT PILOT MODELS	7
HYDRAULIC DIAGRAM - 4WS SIDESHIFT MECHANICAL MODELS.....	9
HYDRAULIC DIAGRAM - 4WS SIDESHIFT PILOT MODELS	11
HYDRAULIC DIAGRAM - 4WS CENTER PIVOT PILOT MODELS	13

INDEX

HYDRAULIC PUMP	15
HYDRAULIC FIXED-FLOW-RATE GEAR PUMP	15
HYDRAULIC VARIABLE-FLOW-RATE PISTON PUMP	26
CONTROL VALVES.....	40
LOADER CONTROL VALVE	49
BACKHOE ATTACHMENT CONTROL VALVE.....	53
RELIEF VALVES.....	65
BACKHOE ATTACHMENT CONTROL VALVE PILOT SOLENOID VALVE	74
ACCUMULATOR “GLIDE RIDE” PARKER.....	77
TECHNICAL SPECIFICATIONS.....	77
MAINTENANCE	77
SAFETY	77
CHECKING AND ADJUSTING THE PRECHARGE PRESSURE	78
HYDRAULIC SWING SYSTEM	80
OPERATION	80
HYDRAULIC CYLINDERS.....	83
LOADER ATTACHMENT BOOM CYLINDER.....	84
LOADER BUCKET CYLINDER.....	91
4X1 LOADER BUCKET CYLINDER	97
BACKHOE BOOM CYLINDER	100
BACKHOE ATTACHMENT DIPPER CYLINDER	104
BACKHOE BUCKET CYLINDER.....	108
TELESCOPIC CYLINDER	112
STABILIZER CYLINDER - CENTER PIVOT.....	116
STABILIZER CYLINDER - SIDESHIFT	120
SWING CYLINDER.....	124
BACKHOE ATTACHMENT LOCK CYLINDER - SIDESHIFT	128
SPECIAL TOOLS.....	129
HYDRAULIC CONTROL LEVERS.....	130
TECHNICAL SPECIFICATIONS.....	130
CONTROLS AND OPERATION	131
COMPONENTS	132
DISASSEMBLY AND ASSEMBLY.....	134
CONTROL LEVER VALVE	137
TROUBLESHOOTING	139
PRELIMINARY CHECKS.....	139
TROUBLESHOOTING (WITH “REXROTH” CONTROL VALVES).....	140
SWING	142
HYDRAULIC PUMP	143

SECTION 39 - CHASSIS

DESCRIPTION.....	3
REMOVAL AND INSTALLATION OF COMPONENTS.....	6
COMPONENTS WITHIN THE CHASSIS.....	6
COMPONENTS OF THE LOWER PART OF THE CHASSIS	7
COMPONENTS ATTACHED OUTSIDE THE CHASSIS	11

INDEX

COMPONENTS OF THE UPPER PART	12
 SECTION 41 - STEERING SYSTEM	
DESCRIPTION	3
2WS STEERING SYSTEM	4
4WS STEERING SYSTEM	7
POWER STEERING	11
TECHNICAL SPECIFICATIONS.....	11
COMPONENTS	13
DISASSEMBLY.....	15
ASSEMBLY.....	18
 SECTION 50 - CAB HEATING AND AIR CONDITIONING	
TECHNICAL SPECIFICATIONS.....	3
GENERAL.....	3
CAB HEATING.....	5
CONTROLS	5
OPERATION.....	6
OVERHAUL	9
TROUBLESHOOTING.....	11
AIR CONDITIONING	12
PRINCIPLES OF AIR CONDITIONING	12
CONTROLS	17
OPERATION.....	18
TROUBLESHOOTING AND TESTING.....	25
FLUSHING THE SYSTEM.....	44
DRAINING THE SYSTEM	46
CHARGING THE SYSTEM.....	47
OVERHAUL	48
COMPRESSOR.....	53
TECHNICAL SPECIFICATIONS.....	53
REMOVAL AND INSTALLATION	54
DISASSEMBLY AND ASSEMBLY.....	57
TROUBLESHOOTING.....	66
 SECTION 55 - ELECTRIC SYSTEM	
ELECTRIC DIAGRAMS	3
ELECTRIC DIAGRAMS - POWERSHUTTLE ROPS (B90B)	3
ELECTRIC DIAGRAMS - POWERSHUTTLE CAB (B90B)	19
ELECTRIC DIAGRAMS - POWERSHUTTLE CAB (B100B - B100BTC - B110B - B110BTC)	36
ELECTRIC DIAGRAMS - POWERSHIFT CAB (B110B - B110BTC)	52
ELECTRIC DIAGRAMS - 4WS POWERSHIFT CAB (B115B)	70
CONTROLS AND INSTRUMENTS	88

INDEX

FRONT INSTRUMENT PANEL	88
SIDE INSTRUMENT CLUSTER PANEL (B90B)	91
SIDE INSTRUMENT CLUSTER PANEL (B100B - B100BTC - B110B - B110BTC - B115B).....	93
SIDE INSTRUMENT CLUSTER (B90B)	95
SIDE INSTRUMENT CLUSTER (B100B - B100BTC - B110B - B110BTC - B115B).....	97
ANTI-START SYSTEM	99
DIAGNOSTIC DISPLAY (B100B - B100BTC - B110B - B110BTC - B115B).....	100
SYMBOLS.....	102
SETUP MENU.....	103
PROCEDURE ABOUT SELF TEST.....	104
ON BOARD ERROR CODE RETRIEVAL.....	105
BACKLIGHTING AND DIMMING.....	106
WORK HOURS.....	107
OPERATION.....	108
WARNING SYSTEM.....	112
MAINTENANCE.....	113
WARNING MESSAGES.....	114
STARTING SYSTEM	121
OPERATION.....	121
STARTER MOTOR.....	124
TROUBLESHOOTING.....	129
ALTERNATOR.....	131
TECHNICAL SPECIFICATIONS.....	131
OPERATION.....	131
COMPONENTS.....	133
REMOVAL.....	134
PRELIMINARY CHECKS AND TESTS.....	135
TROUBLESHOOTING.....	144
BATTERY.....	145
TECHNICAL SPECIFICATIONS.....	145
OPERATION.....	145
REPLACEMENT.....	146
CHARGE AND ELECTROLYTE LEVEL CHECK.....	147
CONNECTING A BOOSTER BATTERY.....	148
BATTERY MASTER SWITCH.....	148
TROUBLESHOOTING.....	149

SECTION 82 - LOADER

LOADER ATTACHMENT CONTROLS.....	4
LOADER ATTACHMENT OPERATION.....	4
4x1 LOADER BUCKET CONTROL (Optional).....	7
LOADER ATTACHMENT CONTROL LOCK (Specific to certain countries).....	8
LOADER BUCKET SELF-LEVELLING.....	9
LOADER ATTACHMENT SAFETY STRUT.....	12
LOADER ATTACHMENT SAFETY STRUT	

INDEX

(B90B - B100B - B110B).....	12
LOADER ATTACHMENT SAFETY STRUT	
(B100BTC - B110BTC - B115B)	14
REMOVAL AND INSTALLATION OF LOADER BUCKET	15
LOADER BUCKET (B90B - B100B - B110B)	15
LOADER BUCKET (B100BTC - B110BTC - B115B).....	16
LOADER BUCKET WITH FORKS (Optional)	17
BUCKET TEETH REPLACEMENT.....	18
LOADER REMOVAL.....	19
LOADER ATTACHMENT (B90B - B100B - B110B)	19
LOADER ATTACHMENT	
(B100BTC - B110BTC - B115B)	21

SECTION 84 - BACKHOE

DESCRIPTION AND OPERATION.....	3
BACKHOE ATTACHMENT CONTROLS.....	6
BACKHOE ATTACHMENT MECHANICAL CONTROLS	7
BACKHOE ATTACHMENT HYDRAULIC CONTROLS	17
BACKHOE ATTACHMENT SIDESHIFT (Sideshift version)	23
BACKHOE ATTACHMENT DISASSEMBLY	25
CENTER PIVOT BACKHOE ATTACHMENT DISASSEMBLY	25
SIDESHIFT BACKHOE ATTACHMENT DISASSEMBLY.....	28
BACKHOE BUCKET REPLACEMENT	30
BUCKET TEETH REPLACEMENT.....	31
DIPPER REMOVE	32
TELESCOPIC DIPPER REVISION.....	35
OVERHAUL	35
BACKHOE ATTACHMENT HYDRAULIC HANDLING	38
CONTROLS	38
HYDRAULIC DIAGRAM	38
HANDLING CYLINDER	39
DISASSEMBLY AND ASSEMBLY.....	40

B90B - B90BLR

B100B - B100BLR - B100BTC

B110B - B110BTC

B115B



SECTION 00 - SAFETY RULES

SAFETY INSTRUCTIONS

 **WARNING** 

This warning symbol points out important messages involving your safety.

Carefully read the safety rules contained herein and follow advised precautions to avoid potential hazards and to safeguard your safety and personal integrity.

In this manual you will find this symbol together with the following keywords:

 **WARNING** 

This symbol warns about the possibility of potential damages to the machine that can involve the operator's safety.

 **WARNING** 

With specific warnings about potential dangers for the operator's or other persons integrity directly or indirectly involved.

The non-compliance with the warnings preceded by the above-mentioned keywords (WARNING and DANGER) can cause serious accidents or even the death of the persons involved.

Moreover, in the present Manual, some instructions are given with text in italics, preceded by the words **NOTE** and **CAUTION**.

NOTA: *it emphasizes and underlines to the operator the correct technique or correct procedure to follow.*

 **WARNING** 

This symbol warns about the possibility of potential damages to the machine that can involve the operator's safety.

FOREWORD

Loader backhoes B90B - B90BLR - B100B - B100BLR - B100BTC - B110B - B110BTC - B115B have been designed to perform most earth-moving operations.

If you use this machine for duties involving the use of attachments, accessories, or special tools, consult your Dealer to make sure that the adaptations or modifications carried out are in conformity with the machine's technical specifications and with current regulations on safety.

Any modifications or adaptations which are not approved by the manufacturer may invalidate the machine's original conformity with safety requirements.

The machine must be used according to its intended use, respecting the safety and precautionary rules and strictly following the operating instructions.

Any functional disorders, especially those affecting the safety of the machine, should therefore be rectified immediately.

———— **⚠ DANGER ⚠** ————

A different use of the excavator or of its working equipment:

- for lifting or transporting persons;
- as working platform;
- for lifting loads without the attachment being approved for this purpose;
- for pulling loads;
- is considered unintended use.

Unintended use may cause injury or life-threatening risks for the operator and for other persons.

The manufacturer/supplier cannot be held responsible for any damage resulting from unintended use. The risk involved in such misuse lies entirely with the user.

———— **⚠ DANGER ⚠** ————

It is absolutely forbidden to tamper with and/or change the setting of any of the hydraulic system valves to avoid damaging machine components, with a consequent risk for personal safety.

The current Operator's Manual is the user's guide for correct run-in, use and maintenance of the machine.

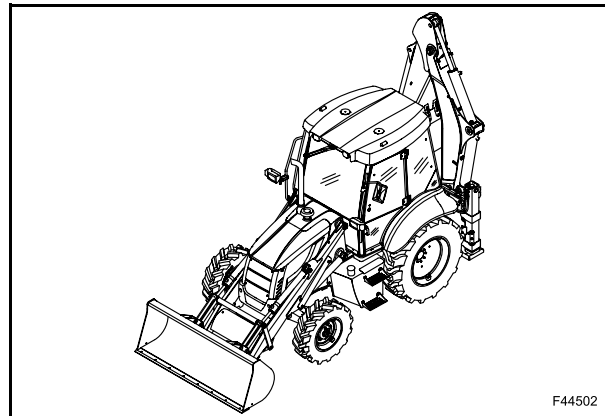

Carefully read this Operator's Manual and store it in the cab for quick location and reference.

Instructions concerning safety, operation and maintenance have been developed to permit safe service and repair of this machine without any risk.

In the event of queries or suggestions relevant to your machine do not hesitate to address to your Dealer.

Dealers have qualified and trained personnel at disposal as well as Original Spares, means and equipment suitable to carry out all necessary maintenance.

Any modifications or adaptations which are not approved by the manufacturer may invalidate the machine's original conformity with safety requirements.

IMPORTANTE: *the engine and fuel system on your machine are designed and built to government emissions standards. Tampering by dealers, customers, operators and users is strictly prohibited by law. Failure to comply with this prohibition could result in government fines, rework charges, invalid warranty, legal action and possible confiscation of the machine until rework to original condition is completed. Engine service and/or repairs must be carried out by a certified technician only.*

NOTA: *each machine is supplied complete with a copy of this Manual. Descriptions and illustrations provided herein are not binding. The Manufacturer, provided that the basic characteristics of machine types described and shown in this Manual remain the same, reserves the right to change components, parts and accessories supplied without any commitment to timely update this publication; and this any time it deems it convenient for improvement purposes or due to commercial or manufacturing requirements. For exact information, please consult your Dealer or contact the Manufacturer's Branch Offices, who remain at your disposal for further help.*

SPARE PARTS

The "non-genuine" spare parts have not been checked and authorized by the Manufacturer.

The assembly and/or use of such products may have negative effects on the machine design features and could impair its operation safety.

The Manufacturer is not liable for any damage caused by "non-genuine" spare parts or accessories.

WARRANTY

This machine is under warranty according to the regulations in force in Your Country and in compliance with the sales agreement drawn up with the Dealer.

The warranty, however, expires if the operation and maintenance instruction for this machine and contained in this manual, have not been followed.

SAFETY INSTRUCTIONS

Carefully read the safety rules contained herein and follow advised precautions to avoid potential hazards and to safeguard your safety and personal integrity.

Your safety and that of the people around you depends on you.

It is essential that you understand this manual for a correct inspection, lubrication and repair of this machine.

Read this manual carefully and check that:

- you understand fully the symbols on the controls and the safety signs used in this manual and on the machine;
- you understand fully the speed, stability, braking and steering characteristics of the machine. If you are in any doubt, consult your Dealer.

The safety messages in this section concern situations which may arise during normal machine operation, servicing and repair. These safety messages also indicate the different ways of coping with these situations. Other safety messages are used throughout the manual to indicate specific dangers.

The information given in this chapter is a summary of the basic rules to respect at all times and does not exempt you from observing traffic regulations or the requirements of insurance companies.

The presence of grease, oil, mud or (in winter) ice on the steps and access handles can cause accidents. Make sure they are always clean.

When mounting or dismounting from the machine always face the machine and use the steps and access handles on the left-hand side of the machine.

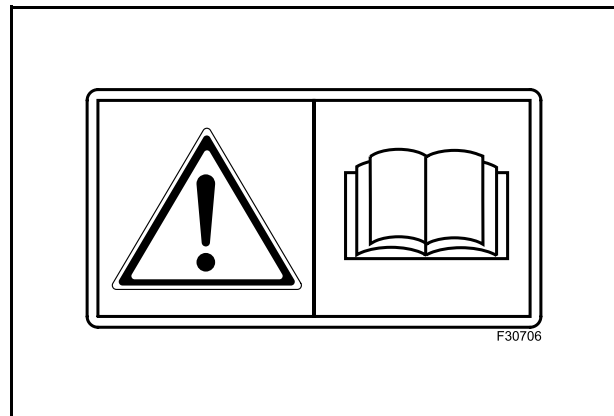

B90B - B90BLR
B100B - B100BLR - B100BTC
B110B - B110BTC
B115B



SECTION 21 - TRANSMISSION

POWERSHUTTLE TRANSMISSION.....	3
TECHNICAL SPECIFICATIONS.....	4
CONTROLS.....	9
LUBRICATION.....	13
GREASING.....	16
REMOVAL FROM MACHINE.....	18
DISASSEMBLY AND ASSEMBLY.....	19
TROUBLESHOOTING.....	144
REPAIR TIMES.....	148
SPECIAL TOOLS.....	149
POWERSHIFT TRANSMISSION.....	150
TECHNICAL SPECIFICATIONS.....	150
CONTROLS.....	161
LUBRICATION.....	163
GREASING.....	165
REMOVAL FROM MACHINE.....	166
DISASSEMBLY AND ASSEMBLY.....	167
TROUBLESHOOTING.....	331
REPAIR TIMES.....	335
SPECIAL TOOLS.....	336

POWERSHUTTLE TRANSMISSION

This transmission is used on powershuttle loader backhoe models B90B-B90BLR-B100B-B100BLR-B100BTC-B110B-B110BTC.

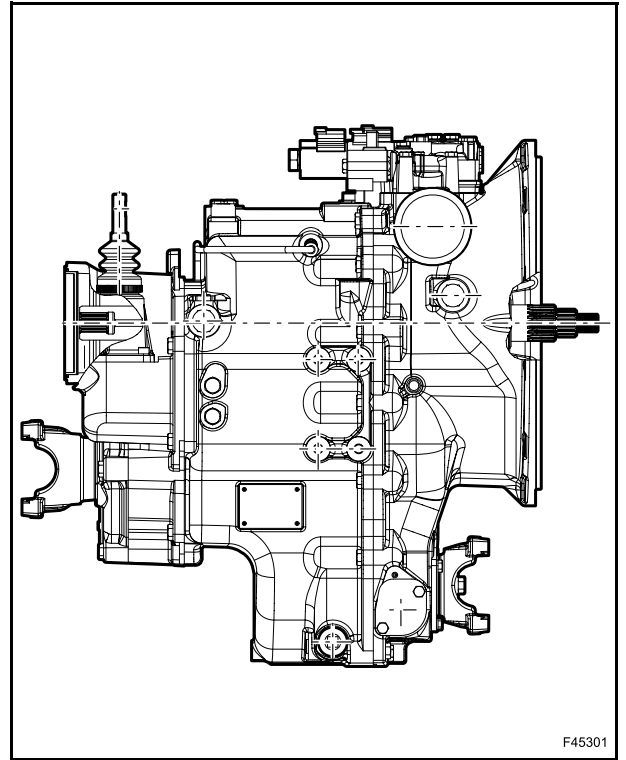

TECHNICAL SPECIFICATIONS

2WD/2WS TRANSMISSION - POWERSHUTTLE (B90B)

Model CARRARO TLB1 MPB 2WD

Type (4x4) 4 forward and 4 reverse travel gears

Torque converter ratio 2.38

Transmission ratios:

1st gear forward travel 5.603:1 reverse travel 4.643:1

2nd gear forward travel 3.481:1 reverse travel 2.884:1

3rd gear forward travel 1.585:1 reverse travel 1.313:1

4th gear forward travel 0.793:1 reverse travel 0.657:1

4WD/2WS TRANSMISSION - POWERSHUTTLE (B90B - B100B - B100BTC - B110B - B110BTC)

Model CARRARO TLB1 MPB 4WD

Type (4x4) 4 forward and 4 reverse travel gears

Torque converter ratio 2.38

Transmission ratios:

1st gear forward travel 5.603:1 reverse travel 4.643:1

2nd gear forward travel 3.481:1 reverse travel 2.884:1

3rd gear forward travel 1.585:1 reverse travel 1.313:1

4th gear forward travel 0.793:1 reverse travel 0.657:1



Suggest:

If the above button click is invalid.

Please download this document

first, and then click the above link

to download the complete manual.

Thank you so much for reading

HYDRAULIC DIAGRAM

2WD

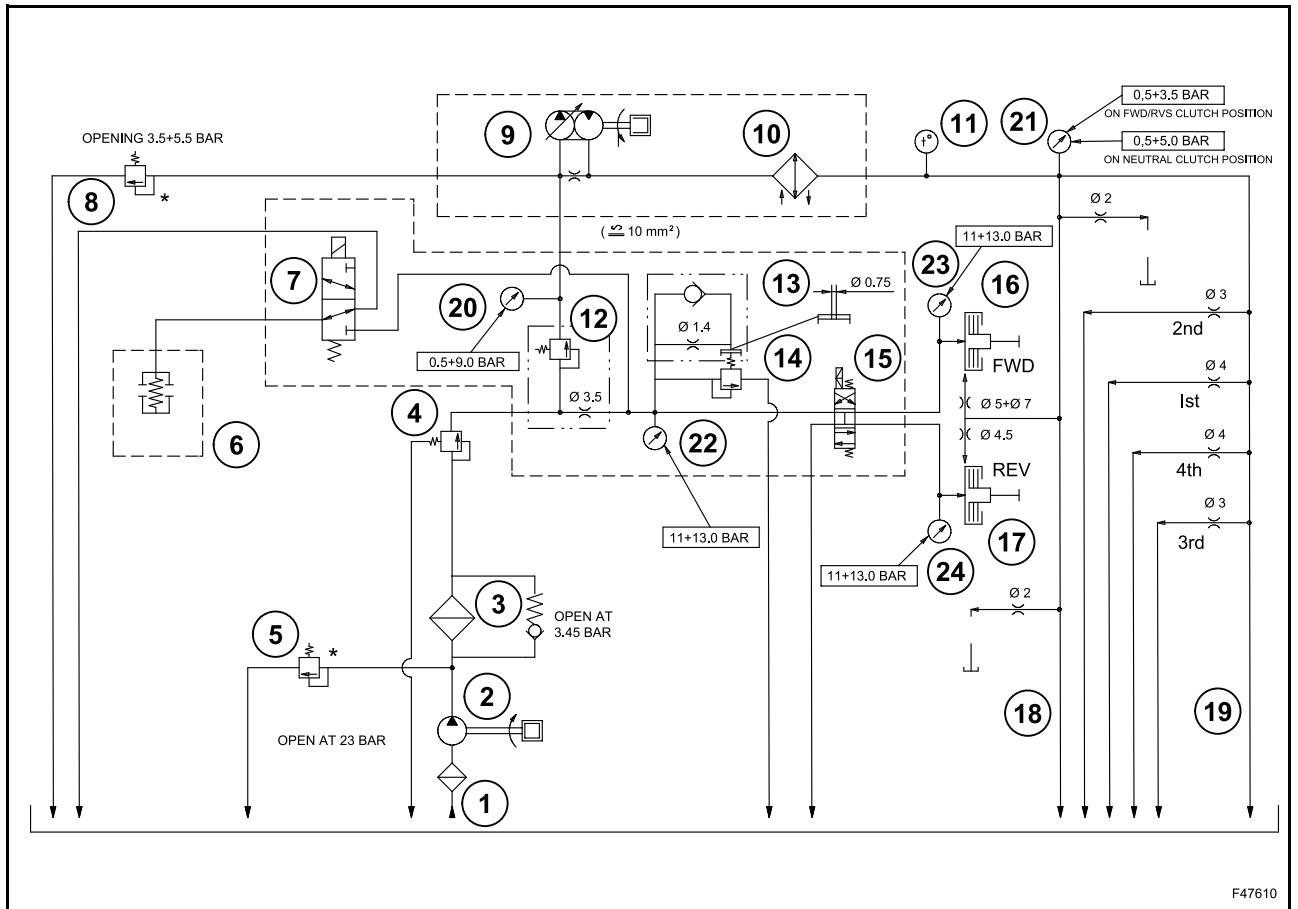

F47610

* located in the pump

<https://www.ebooklibonline.com>

Hello dear friend!

Thank you very much for reading.

Enter the link into your browser.

The full manual is available for immediate download.

<https://www.ebooklibonline.com>