

# SERVICE MANUAL

**9090X Dual / 9090X Olive**  
**9090X Olive Side Conveyor**  
**9090X Side Conveyor**  
Grape Harvester

Part number 51697780

English

November 2019





# **SERVICE MANUAL**

**9090X Dual  
9090X Olive Side Conveyor  
9090X Olive  
9090X Side Conveyor**

## Link Product / Engine

---

<b>Product</b>	<b>Market Product</b>	<b>Engine</b>
9090X Dual T4B - MY18 [770090001 - ]	Europe	F4HFE6139*B004
9090X Olive Olive harvester with Tier 4B engine [770085001 - ]	Europe	F4HFE6139*B004
9090X Olive Side Conveyor Olive harvester TIER 4B Side Conveyor version	Europe	F4HFE6139*B004
9090X Side Conveyor T4B - MY18 [770096001 - ]	Europe	F4HFE6139*B004

**<https://www.ebooklibonline.com>**

Hello dear friend!

Thank you very much for reading.

Enter the link into your browser.

The full manual is available for immediate download.

**<https://www.ebooklibonline.com>**

# Contents

---

## INTRODUCTION

<b>Engine</b> .....	<b>10</b>
[10.001] Engine and crankcase .....	10.1
[10.216] Fuel tanks .....	10.2
[10.310] Aftercooler.....	10.3
[10.400] Engine cooling system .....	10.4
[10.500] Selective Catalytic Reduction (SCR) exhaust treatment.....	10.5
[10.254] Intake and exhaust manifolds and muffler .....	10.6
[10.414] Fan and drive .....	10.7
[10.304] Engine lubrication system.....	10.8
[10.206] Fuel filters .....	10.9
[10.400] Engine cooling system .....	10.10
[10.202] Air cleaners and lines .....	10.11
[10.304] Engine lubrication system.....	10.12
<b>Hydrostatic drive</b> .....	<b>29</b>
[29.218] Pump and motor components.....	29.1
[29.202] Hydrostatic transmission .....	29.2
[29.204] Reservoir, cooler, and lines .....	29.3
<b>Brakes and controls</b> .....	<b>33</b>
[33.202] Hydraulic service brakes .....	33.1
<b>Hydraulic systems</b> .....	<b>35</b>
[35.948] Frame positioning extending .....	35.1
[35.000] Hydraulic systems.....	35.2
[35.104] Fixed displacement pump.....	35.3
[35.300] Reservoir, cooler, and filters.....	35.4
[35.610] Machine leveling control system .....	35.5

[35.946] Frame positioning lifting .....	35.6
[35.706] Fruit repartition system .....	35.7
[35.902] Harvesting hopper hydraulic system .....	35.8
[35.903] Shaking hydraulic system .....	35.9
[35.904] Cleaning hydraulic system .....	35.10
[35.952] Destemmer system .....	35.11
[35.930] Conveyor receiver system .....	35.12
[35.310] Distributor and lines .....	35.13
[35.106] Variable displacement pump .....	35.14
[35.204] Remote control valves .....	35.15
<b>Frames and ballasting .....</b>	<b>39</b>
[39.100] Frame .....	39.1
<b>Steering .....</b>	<b>41</b>
[41.101] Steering control .....	41.1
<b>Wheels .....</b>	<b>44</b>
[44.000] Wheels .....	44.1
[44.520] Rear wheels .....	44.2
<b>Cab climate control .....</b>	<b>50</b>
[50.100] Heating .....	50.1
[50.200] Air conditioning .....	50.2
[50.300] Cab pressurizing system .....	50.3
<b>Electrical systems .....</b>	<b>55</b>
[55.000] Electrical system .....	55.1
[55.050] Heating, Ventilation, and Air-Conditioning (HVAC) control system .....	55.2
[55.100] Harnesses and connectors .....	55.3
[55.640] Electronic modules .....	55.4
[55.019] Hydrostatic drive control system .....	55.5
[55.512] Cab controls .....	55.6

[55.924] Cab fruit harvesting controls .....	55.7
[55.927] Shaking control system .....	55.8
[55.928] Fruit conveyor control system .....	55.9
[55.404] External lighting .....	55.10
[55.408] Warning indicators, alarms, and instruments .....	55.11
[55.988] Selective Catalytic Reduction (SCR) electrical system .....	55.12
[55.302] Battery.....	55.13
[55.101] Chassis harness .....	55.14
[55.201] Engine starting system .....	55.15
[55.DTC] FAULT CODES.....	55.16
<b>Fruit harvester shaking .....</b>	<b>56</b>
[56.300] Shaking frame.....	56.1
[56.301] Shaking control.....	56.2
[56.304] Connecting rods, front plates, and shakers .....	56.3
<b>Product feeding .....</b>	<b>60</b>
[60.320] Fruit harvester conveyor belts.....	60.1
[60.324] Fruit harvester conveyor frame .....	60.2
[60.304] Noria .....	60.3
[60.308] Noria frame and guides .....	60.4
<b>Cleaning .....</b>	<b>74</b>
[74.200] Upper extractors .....	74.1
[74.204] Lower extractors .....	74.2
<b>Secondary cleaning/Destemmer .....</b>	<b>76</b>
[76.200] Sorting table (Opti-grape™).....	76.1
[76.660] Destemmer.....	76.2
<b>Crop storage / Unloading .....</b>	<b>80</b>
[80.300] Fruit conveying system.....	80.1
[80.310] Fruit unloading .....	80.2

<b>Accessories .....</b>	<b>88</b>
[88.100] Accessories .....	88.1
[88.740] Fruit harvester telescopic arm.....	88.2
<b>Tools .....</b>	<b>89</b>
[89.165] Water kit.....	89.1
<b>Platform, cab, bodywork, and decals.....</b>	<b>90</b>
[90.105] Machine shields and guards .....	90.1
<b>Residue handling.....</b>	<b>73</b>
[73.500] Stalk chopper .....	73.1



# INTRODUCTION

---

## **Foreword - Important notice regarding equipment servicing**

All repair and maintenance work listed in this manual must be carried out only by qualified dealership personnel, strictly complying with the instructions given, and using, whenever possible, the special tools.

Anyone who performs repair and maintenance operations without complying with the procedures provided herein shall be responsible for any subsequent damages.

The manufacturer and all the organizations of its distribution chain, including - without limitation - national, regional, or local dealers, reject any responsibility for damages caused by parts and/or components not approved by the manufacturer, including those used for the servicing or repair of the product manufactured or marketed by the manufacturer. In any case, no warranty is given or attributed on the product manufactured or marketed by the manufacturer in case of damages caused by parts and/or components not approved by the manufacturer.

The manufacturer reserves the right to make improvements in design and changes in specifications at any time without notice and without incurring any obligation to install them on units previously sold. Specifications, descriptions, and illustrative material herein are as accurate as known at time of publication but are subject to change without notice.

In case of questions, refer to your NEW HOLLAND Sales and Service Networks.

## Safety rules

### Personal safety



This is the safety alert symbol. It is used to alert you to potential personal injury hazards. Obey all safety messages that follow this symbol to avoid possible death or injury.

Throughout this manual you will find the signal words DANGER, WARNING, and CAUTION followed by special instructions. These precautions are intended for the personal safety of you and those working with you.

Read and understand all the safety messages in this manual before you operate or service the machine.

 DANGER indicates a hazardous situation that, if not avoided, will result in death or serious injury.

 WARNING indicates a hazardous situation that, if not avoided, could result in death or serious injury.

 CAUTION indicates a hazardous situation that, if not avoided, could result in minor or moderate injury.

**FAILURE TO FOLLOW DANGER, WARNING, AND CAUTION MESSAGES COULD RESULT IN DEATH OR SERIOUS INJURY.**

### Machine safety

**NOTICE:** Notice indicates a situation that, if not avoided, could result in machine or property damage.

Throughout this manual you will find the signal word Notice followed by special instructions to prevent machine or property damage. The word Notice is used to address practices not related to personal safety.

### Information

**NOTE:** Note indicates additional information that clarifies steps, procedures, or other information in this manual.

Throughout this manual you will find the word Note followed by additional information about a step, procedure, or other information in the manual. The word Note is not intended to address personal safety or property damage.

---

## Safety rules - Ecology and the environment

Soil, air, and water quality is important for all industries and life in general. When legislation does not yet rule the treatment of some of the substances that advanced technology requires, sound judgment should govern the use and disposal of products of a chemical and petrochemical nature.

Familiarize yourself with the relative legislation applicable to your country, and make sure that you understand this legislation. Where no legislation exists, obtain information from suppliers of oils, filters, batteries, fuels, anti-freeze, cleaning agents, etc., with regard to the effect of these substances on man and nature and how to safely store, use, and dispose of these substances.

### Helpful hints

- Avoid the use of cans or other inappropriate pressurized fuel delivery systems to fill tanks. Such delivery systems may cause considerable spillage.
- In general, avoid skin contact with all fuels, oils, acids, solvents, etc. Most of these products contain substances that may be harmful to your health.
- Modern oils contain additives. Do not burn contaminated fuels and or waste oils in ordinary heating systems.
- Avoid spillage when you drain fluids such as used engine coolant mixtures, engine oil, hydraulic fluid, brake fluid, etc. Do not mix drained brake fluids or fuels with lubricants. Store all drained fluids safely until you can dispose of the fluids in a proper way that complies with all local legislation and available resources.
- Do not allow coolant mixtures to get into the soil. Collect and dispose of coolant mixtures properly.
- The air-conditioning system contains gases that should not be released into the atmosphere. Consult an air-conditioning specialist or use a special extractor to recharge the system properly.
- Repair any leaks or defects in the engine cooling system or hydraulic system immediately.
- Do not increase the pressure in a pressurized circuit as this may lead to a component failure.
- Protect hoses during welding. Penetrating weld splatter may burn a hole or weaken hoses, allowing the loss of oils, coolant, etc.

### Battery recycling

Batteries and electric accumulators contain several substances that can have a harmful effect on the environment if the batteries are not properly recycled after use. Improper disposal of batteries can contaminate the soil, groundwater, and waterways. NEW HOLLAND strongly recommends that you return all used batteries to a NEW HOLLAND dealer, who will dispose of the used batteries or recycle the used batteries properly. In some countries, this is a legal requirement.



### Mandatory battery recycling

**NOTE:** The following requirements are mandatory in Brazil.

Batteries are made of lead plates and a sulfuric acid solution. Because batteries contain heavy metals such as lead, CONAMA Resolution 401/2008 requires you to return all used batteries to the battery dealer when you replace any batteries. Do not dispose of batteries in your household garbage.

Points of sale are obliged to:

- Accept the return of your used batteries
- Store the returned batteries in a suitable location
- Send the returned batteries to the battery manufacturer for recycling



# **SERVICE MANUAL**

## **Engine**

**9090X Dual  
9090X Olive Side Conveyor  
9090X Olive  
9090X Side Conveyor**

---

## Engine and crankcase - Overview - of the engine frame - 9090L and 9090X

The engine is held in a frame that rests on an engine mount.  
The engine mount provides a connection between the machine chassis and the engine.

On 9090X models, the 6-cylinder engine does not vibrate. The frame has no silent blocks, the engine is directly screwed onto its supports.



COIL17GR03405TA 1

The frame surrounds the engine. The frame supports various components such as the radiators, the engine fan, the emission control system, etc.

## Engine and crankcase - Detailed view - Servo belt

Check the rotation of the tensioners (1) every year.  
The servo belt should be replaced every **1200 h**.

The servo belt drives:

- The water pump
- The alternator

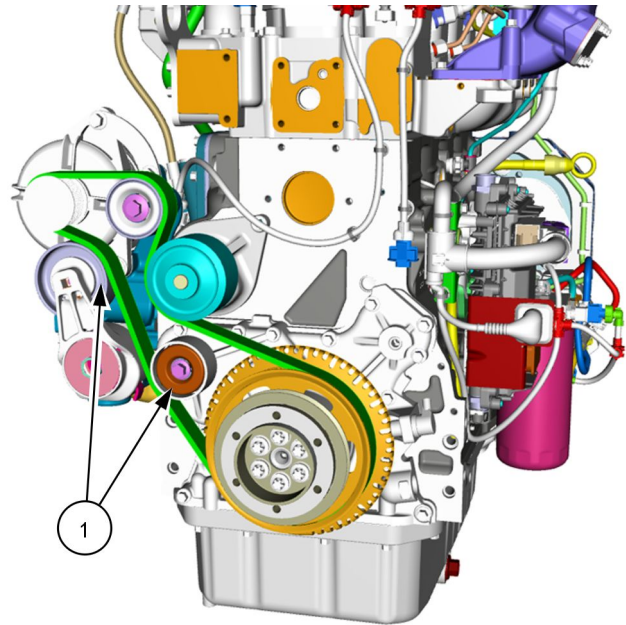

COIL16GR03959QA 1

Replacing the belt/water pump

**Water pump pulley - Replace (10.414)**

---

## Engine and crankcase - Detailed view - The flex disc

The junction between the engine and the H1P 130 (9000MLX) or H1P 115 (7030M/7030L/8030L) pump or Rexroth pump (9080N) is provided by a flex disc.

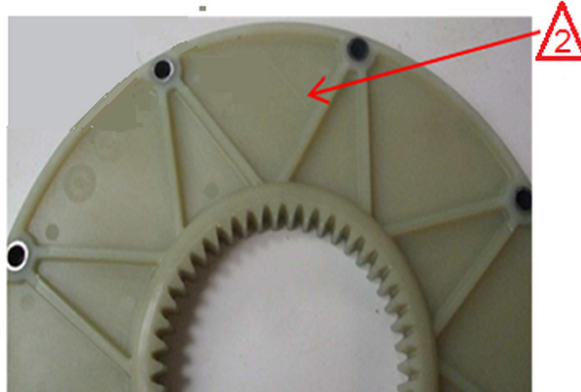

COIL15GR01228PA 1

**NOTE:** On the flex disc, the marking (2) (mounted long side) must be directed towards the engine flywheel.

## Engine and crankcase - Overview - GENERAL COMBUSTION ENGINE

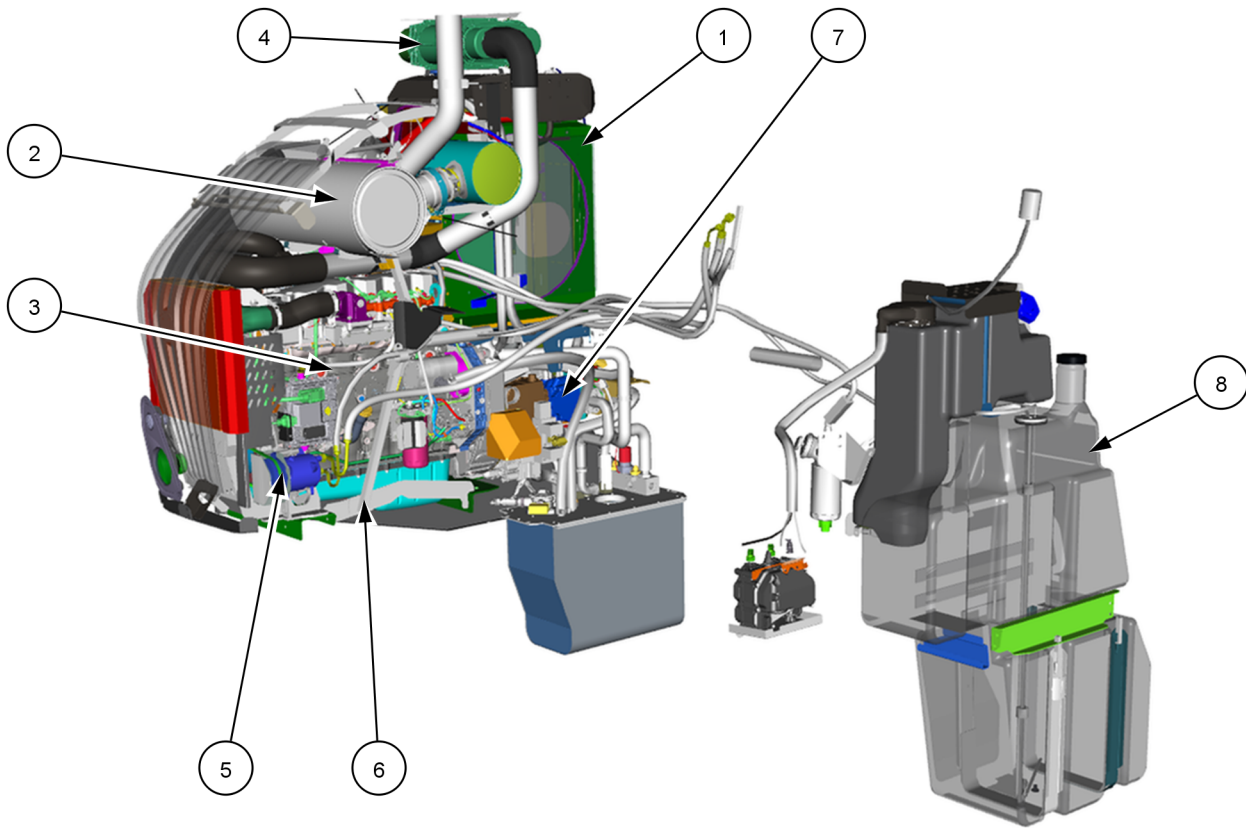

COIL17GR03400TA 1

1	Cooling system	<b>Engine cooling system - Overview - General specifications - Engine coolant (10.400)</b>
2	Exhaust gas after treatment - SCR	<b>Selective Catalytic Reduction (SCR) exhaust treatment - Overview (10.500)</b>
3	Engine – General specifications	<b>Engine - Detailed view (10.001)</b>
4	Air cleaner	<b>Air cleaner - Detailed view (10.202)</b>
5	Servo belt	<b>Engine - Detailed view - Servo belt (10.001)</b>
6	Engine stand	<b>Engine and crankcase - Overview - of the engine frame - 9090L and 9090X (10.001)</b>
7	Pumps	<b>Engine and crankcase - Detailed view - Pumps (10.001)</b>
8	Fuel system	<b>Fuel tank - Overview (10.216)</b>
9	Flector	<b>Engine and crankcase - Detailed view - The flex disc (10.001)</b>



**Suggest:**

**If the above button click is invalid.**

**Please download this document**

**first, and then click the above link**

**to download the complete manual.**

**Thank you so much for reading**

## Engine and crankcase - Detailed view - Pumps

There are four pumps on the engine:

- The forward-travel pumps (1), the cleaning pump (2) and the shaker pump (3) are flanged to the engine flywheel.
- The tandem pump (4) which supplies the lift, the steering, the noria in washing mode and the engine fan (with or without reverse control), spacing of the shaker frame and the grand export arm. The tandem pump is on the inner surface of the engine.

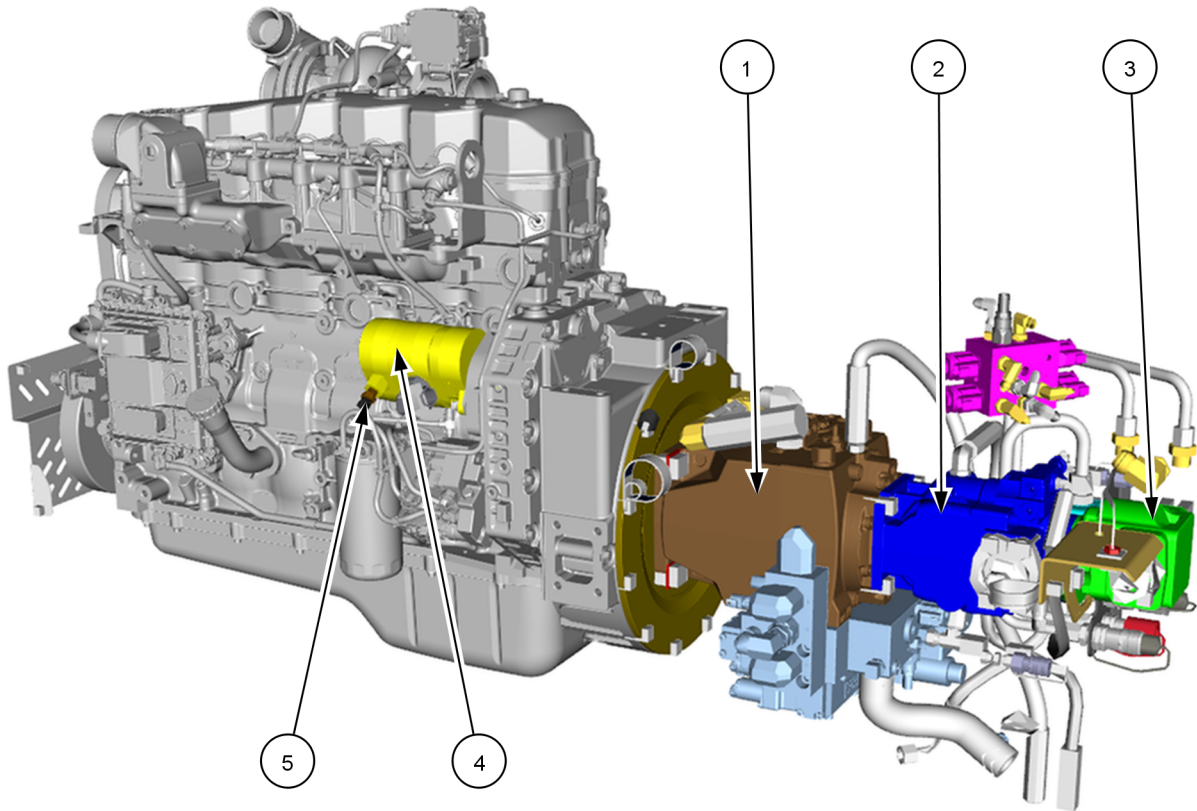

COIL17GR03401TA 1

The hydraulic oil temperature sensor (5) is on the tandem pump.

**<https://www.ebooklibonline.com>**

Hello dear friend!

Thank you very much for reading.

Enter the link into your browser.

The full manual is available for immediate download.

**<https://www.ebooklibonline.com>**