

VERSATILE

Service Manual



Designation 6 Tractor

Issue 1-91
(Replaces All Previous Issues)



CONTENTS

SECTION 1 – SPECIFICATIONS AND DATA	1-1
SECTION 2 – ENGINE SYSTEMS	2-1
SECTION 3 – 12-SPEED MECHANICAL TRANSMISSION	3-1
SECTION 4 – 15-SPEED MECHANICAL TRANSMISSION	4-1
SECTION 5 – DRIVE TRAIN	5-1
SECTION 6 – POWERSHIFT TRANSMISSION	6-1
SECTION 7 – HYDRAULICS	7-1
SECTION 8 – ELECTRICAL SYSTEMS	8-1
SECTION 9 – ENVIRONMENTAL SYSTEMS	9-1
SECTION 10 – STRUCTURES	10-1
SECTION 11 – THREE-POINT HITCH	11-1
SECTION 12 – BRAKES	12-1
INDEX	12-13

Safety

This section contains general safety precautions which should be thoroughly studied and practised by all service personnel. Refer to your tractor Operator's Manual for more detailed safety information.

GENERAL SAFETY

1. Mount a fire extinguisher near the service area. Maintain it as recommended by the manufacturer.
2. Never operate the tractor in an enclosed building. If it is absolutely necessary to do so, be sure the building is well ventilated and ducting is used to direct exhaust fumes outside.
3. Always keep sleeves, jackets or other loose clothing relatively tight and belted. Loose clothing might catch in moving tractor parts.
4. Never jump from the cab. Always use steps and handholds when mounting and dismounting tractor.
5. Park the tractor on a clear, level area before beginning any maintenance procedure. Shut down the engine and remove key; apply parkbrake; chock the front and back of at least two wheels. Ensure all operating controls are in neutral. Always disengage the PTO clutch and three-point hitch. Engage articulation lock.
6. Always lower implements to the ground when leaving equipment.
7. Always operate tractor controls from the operator's seat.
8. Use articulation lock during tractor servicing. See Section 10, STRUCTURES.

TRANSPORT SAFETY

1. Use a trailer with a carrying capacity of at least 18 tonnes (20 tons) to haul the tractor.

2. Securely chain the tractor to the trailer, block the wheels and engage the parkbrake to prevent tractor movement. Engage articulation lock.

JACKING SAFETY

1. Select a jack strong enough to carry the load. The minimum required jack capacity is 4.5 tonnes (5 tons).
2. Stabilize the tractor by putting transmission into gear, engaging the parkbrake and chocking wheels securely. Engage articulation lock.
3. To prevent jackknifing, use two hoists or two rear jacks to lift the rear frame.
4. Secure the jack under the axle tube, frame or drawbar where it is strong enough to keep the jack from tipping, sinking or shifting. Any additional blocking should be under the jack.
5. Jack up the front and/or rear frame just enough to install steel safety stands under the axle tubes or frame.
6. Check the jack position after it has started to lift. Lower the jack immediately if it starts to lean. Reset the jack; block the tractor more securely and lift again.
7. Keep the tractor stable by not raising it so high that it will slide off the jack.
8. Put support stands under the tractor. Lower the jack and let the tractor rest on the stands. This provides solid support for the tractor when the jack is removed.

HOIST SAFETY

1. Use a chain hoist and frame to lift the tractor. The minimum hoist capacity required is 9 tonnes (10 tons); 7 257 kg (8 tons) for the A-frame or overhead support and 2 721 kg (3 tons) for the support stands.
2. Protect yourself from injury when tractor is being raised by observing the following precautions:
 - a. Do not stand on the tractor when it is being lifted.

<https://www.ebooklibonline.com>

Hello dear friend!

Thank you very much for reading.

Enter the link into your browser.

The full manual is available for immediate download.

<https://www.ebooklibonline.com>

- b. Keep hands away from pinch points where the chain links tighten or the chain is against the tractor frame.
 - c. Do not let the tractor swing and strike personnel or the frame as it leaves the ground.
 - d. Keep support stands nearby and place under the tractor when the necessary height is reached.
 - e. Do not go under a tractor supported by a chain hoist. Put support stands under the tractor before working under it.
 - f. Engage articulation lock.
 - g. A cab support is available where better access is required.
3. Extreme care must be exercised when hoisting, lowering or moving any transmission component.

MAINTENANCE SAFETY

1. Shut down engine before repairing tractor.
2. Be alert when approaching the tractor while it is running. Be especially careful around the PTO, articulation joint and three-point hitch.
3. Engage articulation lock during overhaul operations.
4. Never oil, grease or adjust the tractor while it is moving. Never run engine while tractor is being adjusted, cleaned or repaired.
5. Before repairing any hydraulic system component, shut down engine and move all implement controls forward and backward several times to relieve pressure. Disconnect any components connected to the hoses.
6. Wear a face shield or goggles to protect your eyes and heavy gloves to protect your hands when searching for hydraulic leaks or charging the air conditioning system.
7. Escaping hydraulic oil under pressure can penetrate the skin causing severe personal injury.

Use a piece of cardboard or wood as a backstop when searching for leaks. If injured by escaping hydraulic oil, get immediate medical attention.

8. Do not smoke; avoid open flames when filling batteries.
9. Shut down engine and remove key before disconnecting or servicing PTO drivelines.
10. Do not remove radiator cap while the engine is hot. Let engine cool below 74° C (165° F) before removing cap.
11. Stop engine before making any linkage adjustments.
12. Welding fuel tanks is dangerous and not recommended.
13. Repair adhesive is flammable. Keep adhesive and its vapors from heat, sparks and flame.
14. During adhesive use, and until vapor is gone, avoid using spark producing electrical equipment. Keep container closed when not in use.
15. Use adhesive only in a well ventilated area.

FUEL AND FLUID SAFETY

1. Do not smoke; avoid open flame when:
 - a. Filling the fuel tanks
 - b. Filling batteries
 - c. Working near a disassembled air conditioning system. Refrigerant vapor and flame combined produce lethal phosgene gas.
2. Add coolant to the radiator only when the engine is OFF. Turn the radiator cap slightly to relieve pressure before completely removing it.
3. Do not use an open pail or can for transporting fuel. Use only an approved container manufactured for that purpose.
4. If clothes are splashed with fuel, change immediately. Fuel soaked clothes are an extreme fire hazard.

SECTION 2

ENGINE SYSTEMS

1 Introduction

1.1 SPECIFICATIONS AND DATA

1.1.1 756

Engine

Full load Governed Speed 2 100 r/min
 Idle Speed 1 000 r/min
 Bore 114 mm (4.49 in.)
 Stroke 135 mm (5.32 in.)
 Compression Ratio 16.5:1
 Displacement 8.3 L (506 cubic in.)
 Firing Order 153624
 Max. Power 142 kW (190 hp) at 2 100 r/min
 Max. Torque 838 N.m (618 lbf ft) at 1 500 r/min
 Oil Capacity 19 L (20 qt US)
 Torque Rise 30%
 Weight (wet) 636 Kg (1 402 lb)

Cooling System

Capacity 37.5 L (40 qt US)
 Fan 660 mm (26 in.) dia 8 blade
 sucker type belt driven
 Pressure Cap 48 Kpa (7 psi)
 Radiator 5 540 cm² (859 in.²) 6 row core
 with 3.5 fins per cm (9 fins per in.)
 Surge Tank 14.5 L (15 qt US) with pressure
 cap and low coolant
 level probe

Exhaust System

Type Single pipe through front hood
 with integral vacuum aspirator
 for engine precleaner

Fuel Tank

Capacity Total 933 L (246 gal US)
 Usable 887 L (234 gal US)

Type .. Two low mounted interconnected tanks
 filler and drain on each tank, fuel level
 indicator on right tank, duplicate
 electrical gauge on instrument panel
 Remote breather on cab right side

1.1.2 836, 856, 876

Engine

Full Load Governed Speed 2 100 r/min
 Idle Speed 1 000 r/min
 Displacement 10 L (610 cubic in.)
 Firing Order 153624
 Bore 125 mm (4.92 in.)
 Stroke 136 mm (5.35 in.)
 Oil Capacity 26 L (27 qt US)
 Weight (wet) 922 Kg (2 030 lb)

836

Max. Power 156 kW (210 hp) at 2 100 r/min
 Max. Torque 926 N.m (683 lbf ft) at
 1 300 r/min

856

Max. Power 178 kW (240 hp) at 2 100 r/min
 Max. Torque 1 057 N.m (780 lbf ft) at
 1 300 r/min

876

Max. Power 208 kW (280 hp) at 2 100 r/min
 Max. Torque 1 213 N.m (895 lbf ft) at
 1 300 r/min

Cooling System

Capacity 52.1 L (55 qt US)
 Fan 710 mm (28 in.) dia 8 blade
 sucker type belt driven
 Pressure Cap 48 Kpa (7 psi)
 Radiator 5 540 cm² (859 in.²) 6 row core
 with 3.5 fins per cm (9 fins per in.)

Surge Tank 14.5 L (15 qt US) with pressure cap and low coolant level probe

Exhaust System

Type Single oval muffler on right side with integral vacuum aspirator for engine precleaner

Fuel Tank

Capacity Total 933 L (246 gal US)
Usable 887 L (234 gal US)

Type .. Two low mounted interconnected tanks filler and drain on each tank, fuel level indicator on right tank, duplicate electrical gauge on instrument panel
Remote breather on cab right side

1.1.3 936, 956, 976

Engine

Full load Governed Speed 2 100 r/min

Idle Speed 1 000 r/min

Firing Order 153624

Bore 140 mm (5.5 in.)

Stroke 152 mm (6 in.)

Displacement 14 L (855 cubic in.)

Oil Capacity 37 L (39.2 qt US)

Weight (wet) 1 350 Kg (2 970 lb)

Model 936

Type Cummins NTA-855-A-310

Maximum horsepower 230 kW (310 hp)
at 2 100 r/min

Peak Torque 1 432 N.m (1 056 lbf ft)
at 1 400 r/min

Model 956

Type Cummins NTA-855-A-335

Maximum horsepower 250 kW (335 hp)
at 2 100 r/min

Peak Torque 1 543 N.m (1 138 lbf ft)
at 1 400 r/min

Model 976

Type Cummins NTA-855-A-360

Maximum horsepower 268 kW (360 hp)
at 2 100 r/min

Peak Torque 1 587 N.m (1 170 lbf ft)
at 1 400 r/min

Cooling System

Capacity 60.3 L (63.7 qt US)

Fan 813 mm (32 in.) dia 8 blade
sucker type belt driven

Pressure Cap 48 Kpa (7 psi)

Radiator 7 825 cm² (1 213 in.²) 6 row core
with 3.5 fins per cm (9 fins per in.)

Surge Tank 14.5 L (15 qt US) with 48 kPa
(7 psi) pressure cap and low coolant
level probe

Exhaust System

Muffler One 210 x 290 mm (8.25 x 11.5 in.)

Fuel Tank

Capacity Total 1 085 L (286 gal US)
Usable 1 024 L (270 gal US)

Type .. Two low mounted interconnected tanks
filler and drain on each tank, fuel level
indicator on right tank, duplicate
electrical gauge on instrument panel
Remote breather is above tank

2 Engine Replacement

2.1 SPECIAL TOOLS AND EQUIPMENT

1. Chain hoist, 1 590 kg (3 500 lb) capacity
2. Engine stand
3. Hose plugs

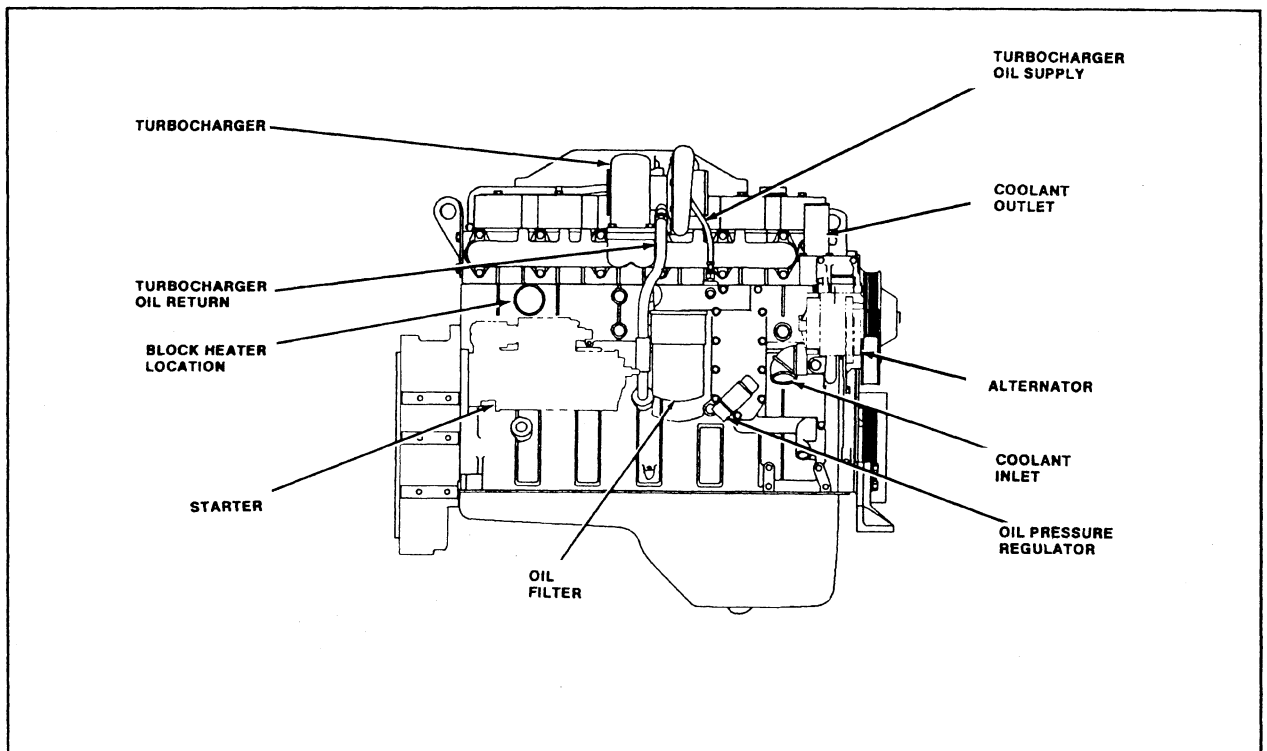

FIGURE 2-1: Engine Right Side

2.2 MODEL 756 ENGINE REMOVAL

CAUTION

SET PARKBRAKE, CHOCK WHEELS AND ENGAGE ARTICULATION LOCK BEFORE SERVICING TRACTOR.

DISCONNECT BATTERY CABLES FIRST TO PREVENT ELECTRICAL DAMAGE FROM OCCURRING.



1. Drain engine oil from pan. Allow 10 min to drain completely and install plug. Tighten plug securely.
2. Drain cooling system thoroughly.
3. Remove flange screws securing fan guards and remove fan guards.
4. Remove tractor hood. Refer to Section 10, STRUCTURES.
5. Remove clamps securing exhaust pipe to turbocharger and remove exhaust pipe. Cover turbocharger opening (Figure 2-1).
6. Remove clamps securing hose between exhaust pipe and air cleaner housing and remove hose.
7. Remove clamps securing air intake tubing to turbocharger, air intake housing and nose piece and remove air intake tubing.
8. Remove flange screws and nuts securing air cleaner housing to frame and remove air cleaner housing.
9. Label and remove hoses from surge tank and radiator to engine. Tie away hoses.

10. Label and remove heater supply and return hoses from engine. Tie away hoses.

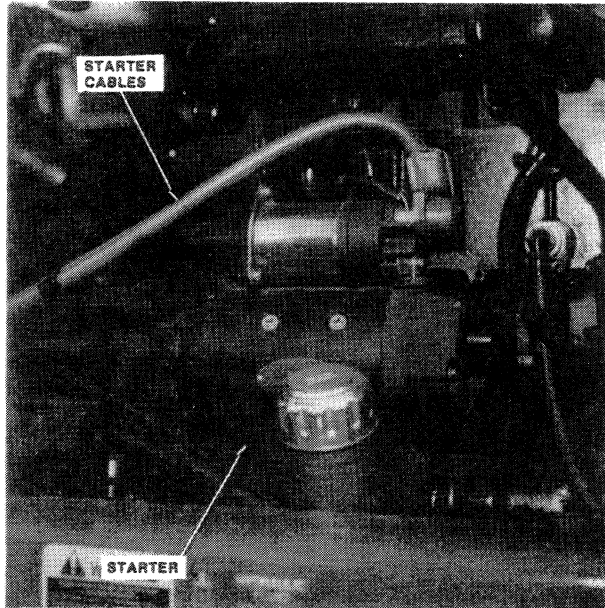

**FIGURE 2-2: Starter Wiring
756 Models**

11. Remove cotterpins securing throttle linkage clevises to fuel pump. Remove nuts securing throttle cables to brackets, remove clips and remove cables. Tie cables away.
12. Label and disconnect fuel lines to lift pump and fuel injection pump. Tie away hoses.
13. Remove tension from alternator and fan drive belt by prying up on automatic tensioner with prybar. Remove drive belt.
14. Label and remove wires from rear of alternator. Tie away wires.
15. Remove capscrews securing alternator to mounting bracket and remove alternator.
16. Label and remove wires and cable from starter motor. Tie away wires and cables.
17. Loosen compressor drive belts and remove belts.
18. Unscrew air conditioning high and low pressure switches from service ports on compressor rear and tie away.

19. Label and disconnect wires to compressor and tie wires away.
20. Remove capscrews and nuts securing compressor to mounting bracket and carefully tie compressor with hoses still connected to outside of lower front frame.

CAUTION

AIR CONDITIONING HOSES ARE UNDER PRESSURE EVEN WHEN THE SYSTEM IS NOT RUNNING.

DO NOT DISCONNECT HOSES, SYSTEM MUST REMAIN CLOSED TO PREVENT CONTAMINATING THE SYSTEM OR DISCHARGING THE REFRIGERANT.



BE ALERT

21. Label and disconnect wire to pressure switch on hydraulic tandem pump.
22. Remove capscrews securing hydraulic tandem pump to engine and carefully tie pump with hoses still connected to outside of lower front frame.

IMPORTANT

Do not disconnect hydraulic hoses from pump to prevent contaminating hydraulic system.

23. Remove capscrew securing cold start thermoguard sensor to engine block and tie away sensor.
24. Remove cold start atomizer from cylinder head and tie away.
25. Label and disconnect wire to magnetic pickup on left side of engine flywheel housing.
26. Remove engine oil pressure sensor from engine block left side and tie away.

27. Remove engine coolant temperature sensor from engine left side and tie away.
28. Disconnect clevises securing clutch linkage to clutch and tie away.
29. Remove capscrews securing universal joint bearing caps on driveline at clutch and disconnect driveline.

IMPORTANT

Ensure needle bearings do not fall out of bearing caps.

30. Remove clutch lubrication hoses from clutch housing and tie away.
31. Position hoist over engine and securely install chain hoist to lift eyes at front and rear of engine. Remove slack from chains.

- CAUTION



ENSURE CHAIN HOIST IS SECURE AND CHAINS WILL NOT SLIP OR SERIOUS PERSONAL INJURY AND/OR MACHINE DAMAGE MAY OCCUR.

32. Remove capscrews and nuts securing engine and mounts to tractor frame.
33. Carefully lift engine slightly and remove engine mounts and washers with a piece of wood.

- CAUTION



DO NOT PUT HANDS BETWEEN ENGINE AND TRACTOR FRAME.

IMPORTANT

Raise engine slowly to prevent damage.

34. Carefully lift engine and mount to engine stand. Guide engine during lifting to avoid striking steering valve.

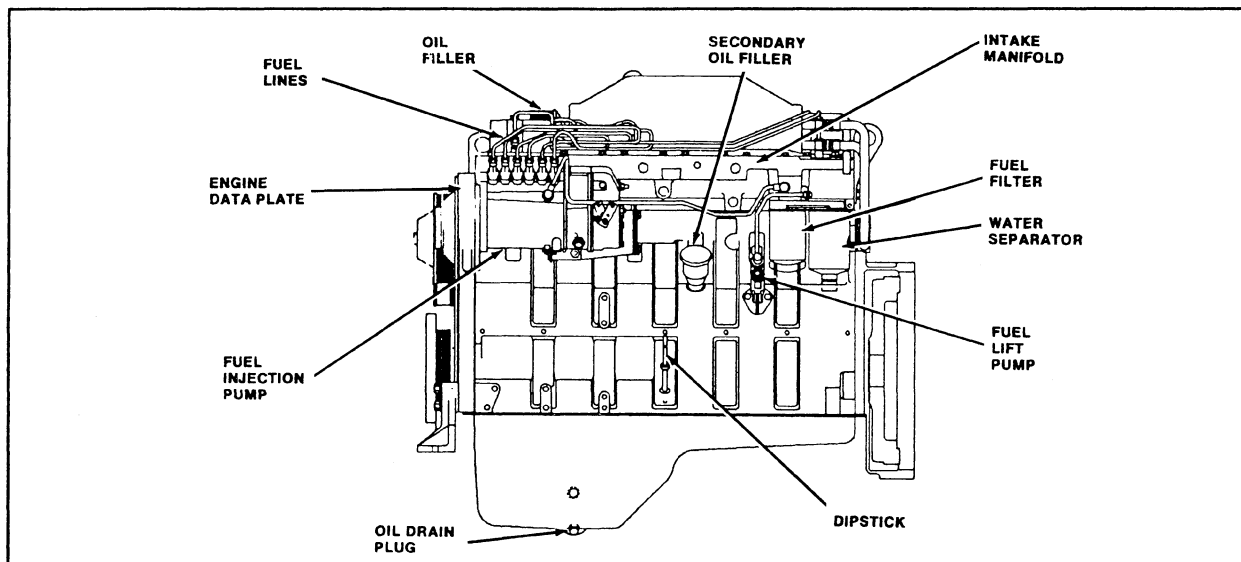

FIGURE 2-3: Engine Left Side

2.3 MODEL 756 ENGINE INSTALLATION

1. Position new engine isolator mounting pads in holes on tractor frame engine mounting points.
2. Position engine over front frame and lower into position taking care not to damage any firewall mounted components, ensure engine mounts, mounting pads and tractor frame holes are properly aligned.
3. Secure engine to tractor frame with capscrews, washers and nuts torqued to 380 N.m (280 lbf ft).
4. Connect input driveline to clutch with capscrews torqued to 110 N.m (80 lbf ft).

IMPORTANT

Ensure input driveline is in phase or severe driveline vibration may occur.

5. Install clutch lubrication hoses to clutch housing.
6. Connect clevises securing clutch linkage to clutch. Use new cotterpins only.
7. Connect wire to magnetic pickup on left side of engine flywheel housing.
8. Install engine oil pressure sensor to engine block left side.
9. Install engine coolant temperature sensor to engine left side.
10. Install cold start thermoguard sensor to engine with capscrew tightened securely.
11. Install cold start atomizer to cylinder head. Tighten fitting.
12. Install hydraulic tandem pump to engine accessory drive with capscrews tightened securely.
13. Connect wire to pressure switch on hydraulic tandem pump.
14. Install compressor to mounting bracket with capscrews and nuts torqued to 40 N.m (30 lbf ft).
15. Install compressor drive belts.
16. Install air conditioning high and low pressure switches to original positions on service ports on compressor rear.
17. Connect wires to compressor.
18. Install wires and cable to starter motor. Tighten connections securely.
19. Install alternator to mounting bracket with capscrews torqued to 40 N.m (30 lbf ft).
20. Pry up on automatic belt tensioner with prybar and install alternator drive belt.
21. Install wires to rear of alternator. Tighten connections securely.
22. Connect fuel lines to lift pump and fuel injection pump. Tighten fittings securely.
23. Install throttle cables to brackets with clips and nuts. Tighten nuts securely.
24. Install throttle linkage clevises to fuel pump. Use new cotterpins.
25. Install heater supply and return hoses to engine. Tighten hoses clamps securely.
26. Install hoses from surge tank and radiator to engine. Tighten hose clamps and fittings securely.
27. Install air cleaner housing to frame with flange screws and nuts tightened securely.
28. Install air intake tubing to turbocharger, air intake housing and nose piece. Tighten clamps securely.
29. Install exhaust pipe to turbocharger. Tighten clamps securely.
30. Install hose between exhaust pipe and air cleaner housing. Tighten hose clamps securely.
31. Install tractor hood. Refer to Section 10, STRUCTURES.

32. Install fan guards with flange screws tightened securely.
33. Connect battery cables.
34. Install a DCA2 precharge filter and fill cooling system with 37.5 L (40 qt US) of a 1:1 mixture of ethyl glycol coolant to water.
35. Install new oil filters and fill engine with 19 L (20 qt US) of SF/CD 15W40 oil.
36. Fill new fuel filters with fuel and install to engine.
37. Push plunger on engine left side to prime fuel system.
38. Start engine and run for 10 minutes. Shut down engine and check for leaks. Top up fluid levels if necessary.

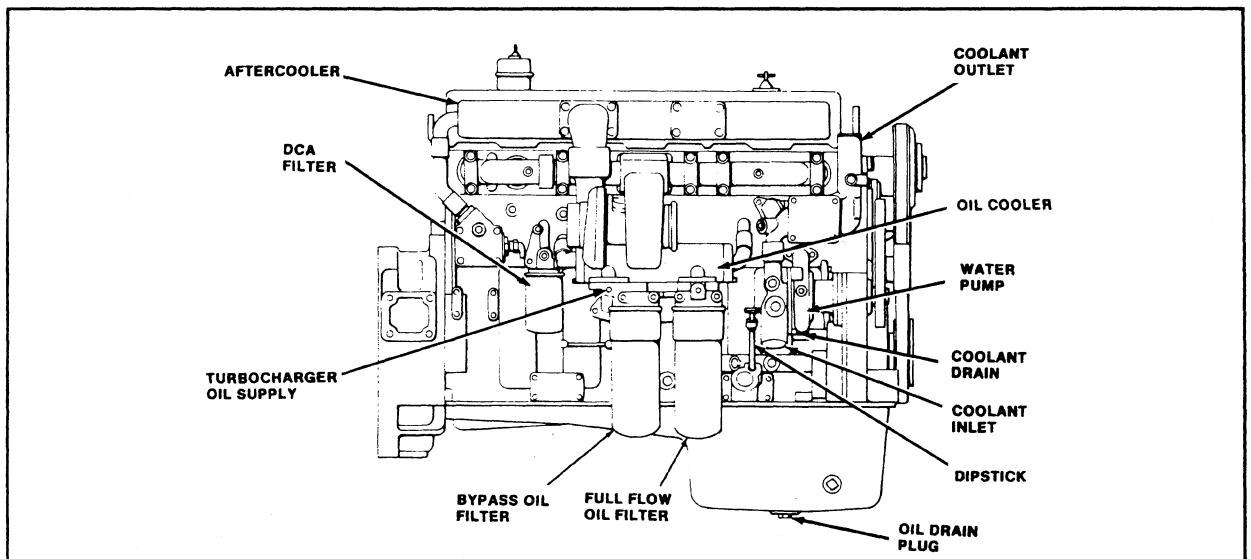

FIGURE 2-4: Engine Right Side

2.4 800 MODELS ENGINE REMOVAL

CAUTION

SET PARKBRAKE, CHOCK WHEELS AND ENGAGE ARTICULATION LOCK BEFORE SERVICING TRACTOR.

DISCONNECT BATTERY CABLES FIRST TO PREVENT ELECTRICAL DAMAGE FROM OCCURRING.



BE ALERT

1. Drain engine oil from pan. Allow 10 min to drain completely and install plug. Tighten plug securely.
2. Drain cooling system thoroughly.
3. Remove flange screws securing fan guards and remove fan guards.
4. Remove tractor hood. Refer to Section 10, STRUCTURES.
5. Remove clamps securing exhaust pipe and muffler to turbocharger and remove exhaust pipe. Cover turbocharger opening.
6. Remove clamps securing hose between exhaust pipe and air cleaner housing and remove hose.
7. Remove clamps securing air intake tubing to turbocharger and air intake housing and remove air intake tubing.

8. Label and remove hoses from surge tank and radiator to engine. Tie away hoses.
9. Label and disconnect wire to coolant level probe on surge tank.
10. Label and remove heater supply and return hoses from engine. Tie away hoses.
11. Remove nuts securing throttle cable to bracket, remove clips and remove cable. Tie cable away.
12. Label and disconnect wires to decelerator solenoid on engine left side.
13. Label and disconnect fuel lines to fuel injection pump. Tie away hoses.
14. Remove tension from alternator drive belt and remove drive belt.
15. Label and remove wires from rear of alternator. Tie away wires.
16. Remove capscrews securing alternator to mounting bracket and remove alternator.
17. Label and remove wires and cable from starter motor. Tie away wires and cables.
18. Loosen compressor drive belts and remove belts.
19. Unscrew air conditioning high and low pressure switches from service ports on compressor rear and tie away.
20. Label and disconnect wires to compressor and tie wires away.
21. Remove capscrews and nuts securing compressor to mounting bracket and carefully tie compressor with hoses still connected to outside of lower front frame.

CAUTION

AIR CONDITIONING HOSES ARE UNDER PRESSURE EVEN WHEN THE SYSTEM IS NOT RUNNING.

DO NOT DISCONNECT HOSES, SYSTEM MUST REMAIN CLOSED TO PREVENT CONTAMINATING THE SYSTEM OR DISCHARGING THE REFRIGERANT.

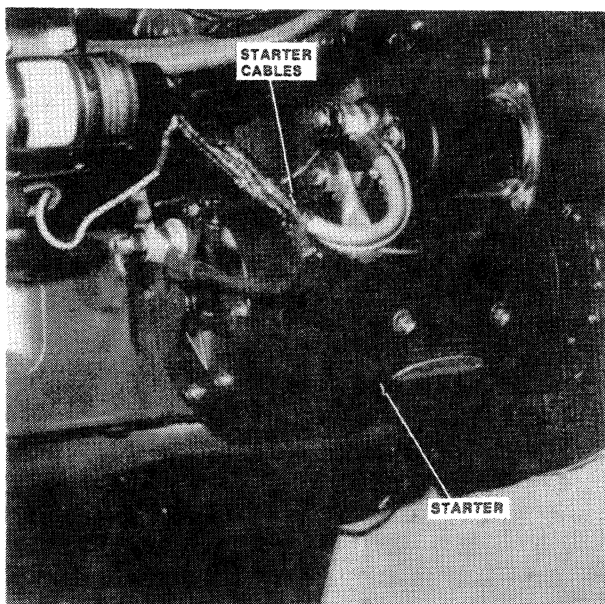

**FIGURE 2-5: Starter Wiring
800 Models**

-
22. Label and disconnect wire to pressure switch on hydraulic piston pump.
 23. Remove capscrews securing hydraulic piston pump to engine and carefully tie pump with hoses still connected to outside of lower front frame.
 24. Remove flange screws and nuts securing hydraulic gear pump to front of engine and carefully tie pump with hoses still connected to lower front frame.

IMPORTANT

Do not disconnect hydraulic hoses from pump to prevent contaminating hydraulic system.

25. Remove capscrew securing cold start thermoguard sensor to engine block and tie away sensor.
26. Remove cold start atomizer from cylinder head and tie away.
27. Label and disconnect wire to magnetic pickup on left side of engine flywheel housing.
28. Remove engine oil pressure sensor from engine block left side and tie away.
29. Remove engine coolant temperature sensor from engine right side and tie away.
30. Disconnect clevises securing clutch linkage to clutch and tie away.
31. Remove capscrews securing universal joint bearing caps on driveline at clutch and disconnect driveline.
32. Remove clutch lubrication hoses from clutch housing and tie away.
33. Position hoist over engine and securely install chain hoist to lift eyes at front and rear of engine. Remove slack from chains.

CAUTION

ENSURE CHAIN HOIST IS SECURE AND CHAINS WILL NOT SLIP OR SERIOUS PERSONAL INJURY AND/OR MACHINE DAMAGE MAY OCCUR.



IMPORTANT
Ensure needle bearings do not fall out of bearing caps.

34. Remove capscrews and nuts securing engine and mounts to tractor frame.
35. Carefully lift engine slightly and remove engine mounts and washers with a piece of wood.

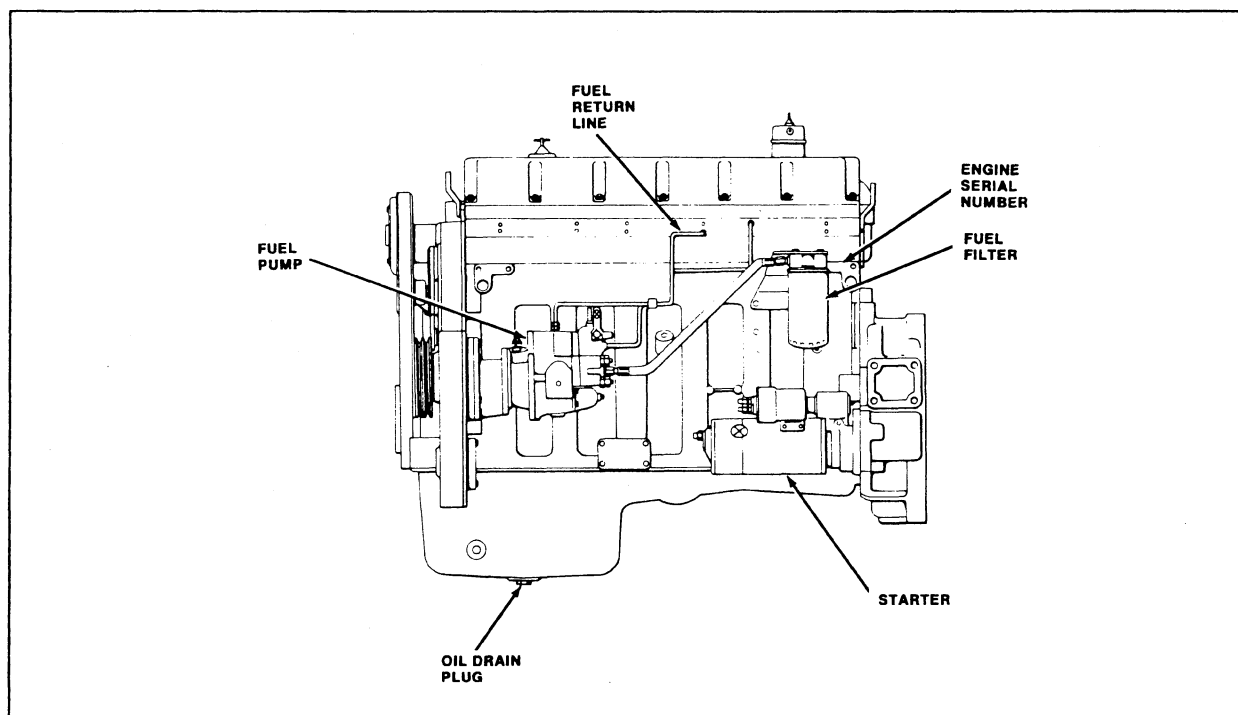

FIGURE 2-6: Engine Left Side

CAUTION



DO NOT PUT HANDS BETWEEN ENGINE AND TRACTOR FRAME.

IMPORTANT

Raise engine slowly to prevent damage.

36. Carefully lift engine and mount to engine stand. Guide engine during lifting to avoid striking steering valve.

2.5 800 MODELS ENGINE INSTALLATION

1. Position new engine isolator mounting pads in holes on tractor frame engine mounting points.
2. Position engine over front frame and lower into position taking care not to damage any firewall mounted components, ensure engine mounts, mounting pads and tractor frame holes are properly aligned.
3. Secure engine to tractor frame with capscrews, washers and nuts torqued to 380 N.m (280 lbf ft).
4. Connect input driveline to clutch with capscrews torqued to 110 N.m (80 lbf ft).

IMPORTANT

Ensure input driveline is in phase or severe driveline vibration may occur.

5. Install clutch lubrication hoses to clutch housing.
6. Connect clevises securing clutch linkage to clutch. Use new cotterpins only.
7. Connect wire to magnetic pickup on left side of engine flywheel housing.

8. Install engine oil pressure sensor to engine block left side.
9. Install engine coolant temperature sensor to engine right side.
10. Install cold start thermoguard sensor to engine with capscrew tightened securely.
11. Install cold start atomizer to cylinder head. Tighten fitting.
12. Install hydraulic piston pump to engine accessory drive with capscrews tightened securely.
13. Connect wire to pressure switch on hydraulic piston pump.
14. Install hydraulic gear pump to front of engine with flange screws and nuts tightened securely.
15. Install compressor to mounting bracket with capscrews and nuts torqued to 40 N.m (30 lbf ft).
16. Install compressor drive belts.
17. Install air conditioning high and low pressure switches to original positions on service ports on compressor rear.
18. Connect wires to compressor.
19. Install wires and cable to starter motor. Tighten connections securely.
20. Install alternator to mounting bracket with capscrews torqued to 40 N.m (30 lbf ft).
21. Install alternator drive belt and tension belt.
22. Install wires to rear of alternator. Tighten connections securely.
23. Connect fuel lines to fuel injection pump. Tighten fittings securely.
24. Install throttle cable to bracket and fuel injection pump with clips and nuts. Tighten nuts securely.
25. Connect wires to decelerator solenoid.

26. Install heater supply and return hoses to engine. Tighten hoses clamps securely.
27. Install hoses from surge tank and radiator to engine. Tighten hose clamps and fittings securely.
28. Install wires to coolant level probe on surge tank.
29. Install air intake tubing to turbocharger and air intake housing. Tighten clamps securely.
30. Install exhaust pipe and muffler to turbocharger. Tighten clamps securely.
31. Install hose between exhaust pipe and air cleaner housing. Tighten hose clamps securely.
32. Install tractor hood. Refer to Section 10, STRUCTURES.
33. Install fan guards with flange screws tightened securely.
34. Connect battery cables.
35. Install a DCA precharge filter and fill cooling system with 52.1 L (55 qt US) of a 1:1 mixture of ethyl glycol coolant to water.
36. Install new oil filters and fill engine with 26 L (27 qt US) of SF/CD 15W40 oil.
37. Fill new fuel filters with fuel and install to engine.
38. Start engine and run for 10 minutes. Shut down engine and check for leaks. Top up fluid levels if necessary.

2.6 900 MODELS ENGINE REMOVAL

CAUTION

SET PARKBRAKE, CHOCK WHEELS AND ENGAGE ARTICULATION LOCK BEFORE SERVICING TRACTOR.

DISCONNECT BATTERY CABLES FIRST TO PREVENT ELECTRICAL DAMAGE FROM OCCURRING.

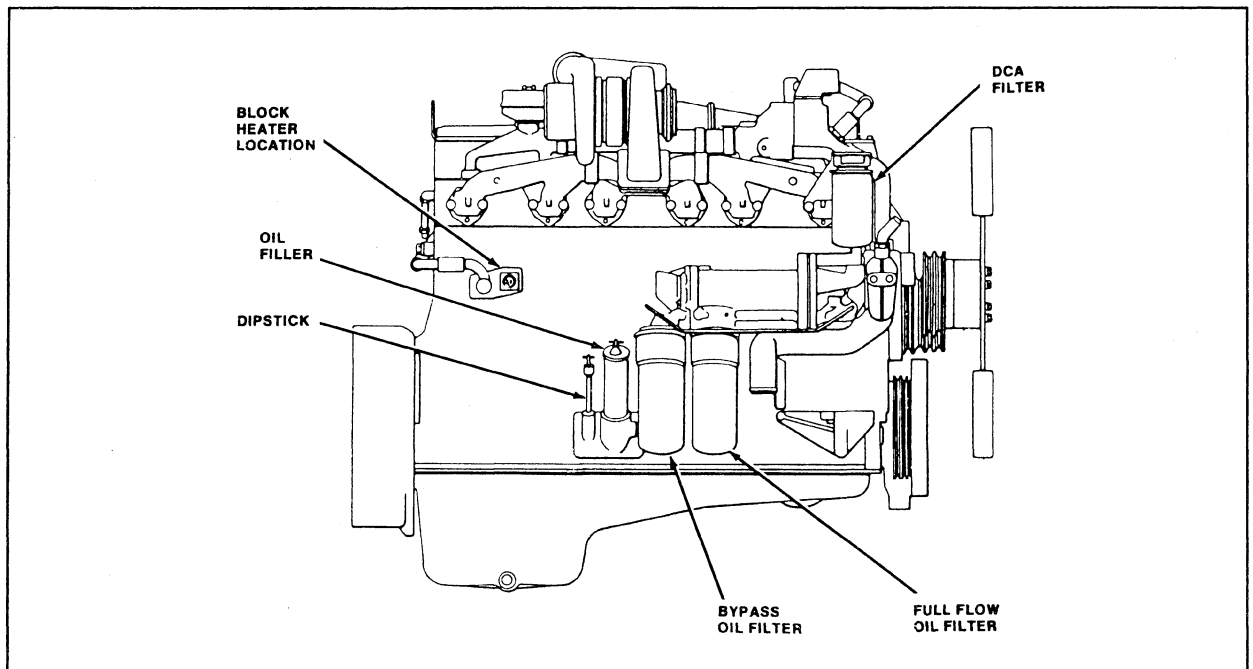
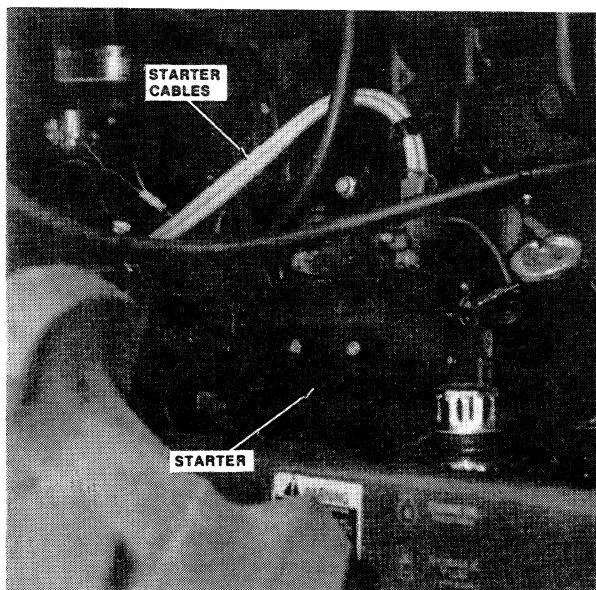

FIGURE 2-7: Engine Right Side

1. Drain engine oil from pan. Allow 10 min to drain completely and install plug. Tighten plug securely.
2. Drain cooling system thoroughly.
3. Remove flange screws securing fan guards and remove fan guards.
4. Remove tractor hood. Refer to Section 10, STRUCTURES.
5. Remove clamps securing exhaust pipe and muffler to turbocharger and remove exhaust pipe. Cover turbocharger opening.
6. Remove clamps securing hose between exhaust pipe and air cleaner housing and remove hose.
7. Remove clamps securing air intake tubing to turbocharger and air intake housing and remove air intake tubing.
8. Label and remove hoses from surge tank and radiator to engine. Tie away hoses.
9. Label and disconnect wire to coolant level probe on surge tank.
10. Label and remove heater supply and return hoses from engine. Tie away hoses.
11. Remove nuts securing throttle cable to bracket, remove clips and remove cable. Tie cable away.
12. Label and disconnect wires to decelerator solenoid on engine left side.
13. Label and disconnect fuel lines to fuel injection pump. Tie away hoses.
14. Relieve tension from alternator drive belt and remove drive belt.
15. Label and remove wires from rear of alternator. Tie away wires.

16. Remove capscrews securing alternator to mounting bracket and remove alternator.
17. Label and remove wires and cables from starter motor. Tie away wires and cables.



**FIGURE 2-8: Starter Wiring
900 Models**

18. Loosen compressor drive belts and remove belts.
19. Unscrew air conditioning high and low pressure switches from service ports on compressor rear and tie away.
20. Label and disconnect wires to compressor and tie wires away.
21. Remove capscrews and nuts securing compressor to mounting bracket and carefully tie compressor with hoses still connected to outside of lower front frame.



Suggest:

If the above button click is invalid.

Please download this document

first, and then click the above link

to download the complete manual.

Thank you so much for reading

CAUTION

AIR CONDITIONING HOSES ARE UNDER PRESSURE EVEN WHEN THE SYSTEM IS NOT RUNNING.

DO NOT DISCONNECT HOSES, SYSTEM MUST REMAIN CLOSED TO PREVENT CONTAMINATING THE SYSTEM OR DISCHARGING THE REFRIGERANT.



BE ALERT

-
22. Label and disconnect wire to pressure switch on hydraulic piston pump.
 23. Remove capscrews securing hydraulic piston pump to engine and carefully tie pump with hoses still connected to outside of lower front frame.
 24. Remove flange screws securing hydraulic gear pump to front of engine and carefully tie pump with hoses still connected to outside of lower front frame.

IMPORTANT

Do not disconnect hydraulic hoses from pump to prevent contaminating hydraulic system.

25. Remove capscrew securing cold start thermoguard sensor to engine block and tie away sensor.
26. Remove cold start atomizer from cylinder head and tie away.
27. Label and disconnect wire to magnetic pickup on left side of engine flywheel housing.
28. Remove engine oil pressure sensor from engine block left side and tie away.

29. Remove engine coolant temperature sensor from engine thermostat housing and tie away.
30. Disconnect clevises securing clutch linkage to clutch and tie away.
31. Remove capscrews securing universal joint bearing caps on driveline at clutch and disconnect driveline.

IMPORTANT

Ensure needle bearings do not fall out of bearing caps.

32. Remove clutch lubrication hoses from clutch housing and tie away.
33. Position hoist over engine and securely install chain hoist to lift eyes at front and rear of engine. Remove slack from chains.

CAUTION

ENSURE CHAIN HOIST IS SECURE AND CHAINS WILL NOT SLIP OR SERIOUS PERSONAL INJURY AND/OR MACHINE DAMAGE MAY OCCUR.



BE ALERT

-
34. Remove capscrews and nuts securing engine and mounts to tractor frame.
 35. Carefully lift engine slightly and remove engine mounts and washers with a piece of wood.

CAUTION

DO NOT PUT HANDS BETWEEN ENGINE AND TRACTOR FRAME.



BE ALERT

<https://www.ebooklibonline.com>

Hello dear friend!

Thank you very much for reading.

Enter the link into your browser.

The full manual is available for immediate download.

<https://www.ebooklibonline.com>