

CVX 140
CVX 150
CVX 160
CVX 175
CVX 195
Tractor

SERVICE MANUAL

Part number 47505517

English

February 2013

Copyright © 2013 CNH Europe Holding S.A. All Rights Reserved.

CASE IH
AGRICULTURE

SERVICE MANUAL

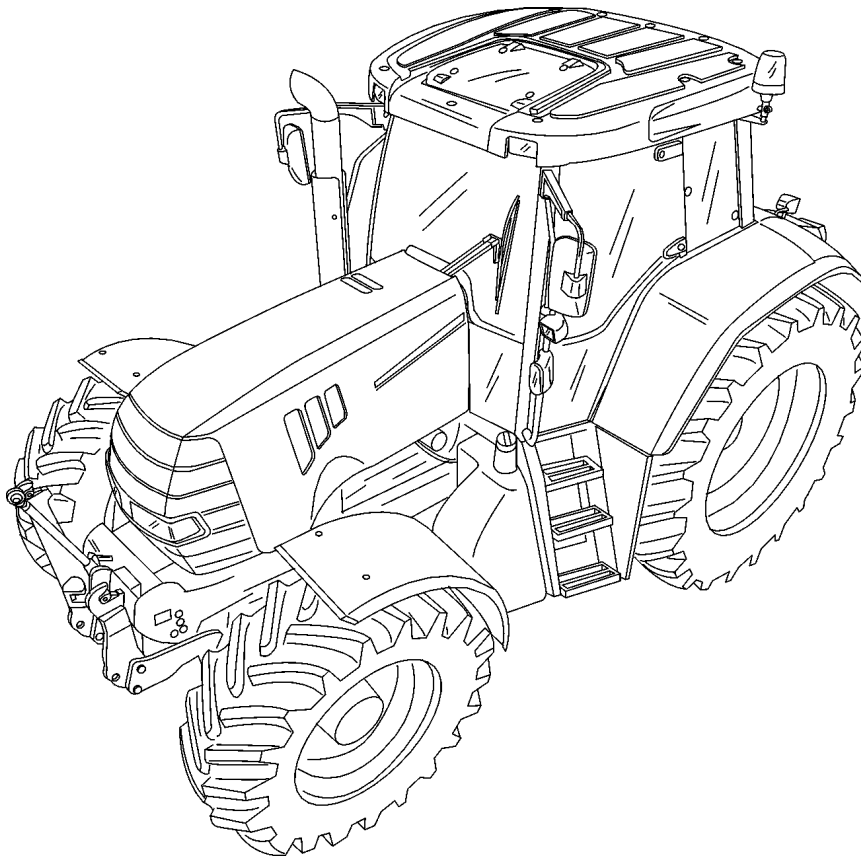

CVX 140
CVX 150
CVX 160
CVX 175
CVX 195

Contents

INTRODUCTION

Engine.....	10
[10.001] Engine and crankcase	10.1
[10.106] Valve drive and gears	10.2
[10.101] Cylinder heads	10.3
[10.105] Connecting rods and pistons.....	10.4
[10.103] Crankshaft and flywheel.....	10.5
[10.218] Fuel injection system.....	10.6
[10.250] Turbocharger and lines.....	10.7
[10.254] Intake and exhaust manifolds and muffler	10.8
[10.400] Engine cooling system	10.9
[10.414] Fan and drive	10.10
[10.304] Engine lubrication system.....	10.11
Transmission.....	21
[21.504] Continuously Variable Transmission (CVT).....	21.1
[21.505] Continuously Variable Transmission (CVT) external controls.....	21.2
[21.506] Continuously Variable Transmission (CVT) lubrication system	21.3
[21.507] Continuously Variable Transmission (CVT) internal components.....	21.4
Four-Wheel Drive (4WD) system	23
[23.202] Electro-hydraulic control	23.1
[23.314] Drive shaft.....	23.2
Front axle system	25
[25.100] Powered front axle	25.1
[25.102] Front bevel gear set and differential	25.2
[25.108] Final drive hub, steering knuckles, and shafts	25.3
[25.122] Axle suspension control.....	25.4

<https://www.ebooklibonline.com>

Hello dear friend!

Thank you very much for reading.

Enter the link into your browser.

The full manual is available for immediate download.

<https://www.ebooklibonline.com>

Rear axle system	27
[27.100] Powered rear axle.....	27.1
[27.106] Rear bevel gear set and differential.....	27.2
[27.120] Planetary and final drives.....	27.3
Power Take-Off (PTO)	31
[31.104] Rear electro-hydraulic control.....	31.1
[31.119] Four-speed rear Power Take-Off (PTO).....	31.2
[31.142] Front Power Take-Off (PTO) control.....	31.3
[31.146] Front Power Take-Off (PTO).....	31.4
Brakes and controls	33
[33.202] Hydraulic service brakes.....	33.1
[33.110] Parking brake or parking lock.....	33.2
[33.220] Trailer brake hydraulic control.....	33.3
[33.204] Front axle brake.....	33.4
[33.200] Brake cooling.....	33.5
Hydraulic systems	35
[35.000] Hydraulic systems.....	35.1
[35.106] Variable displacement pump.....	35.2
[35.359] Main control valve.....	35.3
[35.204] Remote control valves.....	35.4
[35.114] Three-point hitch control valve.....	35.5
[35.116] Three-point hitch cylinder.....	35.6
Steering	41
[41.200] Hydraulic control components.....	41.1
[41.216] Cylinders.....	41.2
[41.432] Autoguidance steering.....	41.3
Cab climate control	50
[50.104] Ventilation.....	50.1

[50.200] Air conditioning	50.2
Electrical systems	55
[55.000] Electrical system	55.1
[55.100] Harnesses and connectors	55.2
[55.525] Cab engine controls	55.3
[55.015] Engine control system	55.4
[55.301] Alternator	55.5
[55.302] Battery	55.6
[55.202] Cold start aid	55.7
[55.011] Fuel tank system	55.8
[55.010] Fuel injection system	55.9
[55.014] Engine intake and exhaust system	55.10
[55.012] Engine cooling system	55.11
[55.013] Engine oil system	55.12
[55.640] Electronic modules	55.13
[55.513] Cab transmission controls	55.14
[55.024] Transmission control system	55.15
[55.020] Transmission speed sensors	55.16
[55.021] Transmission pressure sensors	55.17
[55.022] Transmission temperature sensors	55.18
[55.023] Transmission position sensors	55.19
[55.045] Front axle control system	55.20
[55.048] Rear Power Take-Off (PTO) control system	55.21
[55.049] Front Power Take-Off (PTO) control system	55.22
[55.051] Cab Heating, Ventilation, and Air-Conditioning (HVAC) controls	55.23
[55.050] Heating, Ventilation, and Air-Conditioning (HVAC) control system	55.24
[55.519] Cab brake controls	55.25
[55.030] Service brake electrical system	55.26
[55.032] Trailer brake electrical system	55.27

[55.512] Cab controls.....	55.28
[55.035] Remote control valve electric control	55.29
[55.036] Hydraulic system control	55.30
[55.047] Steering control system	55.31
[55.523] Cab hitch controls	55.32
[55.130] Rear three-point hitch electronic control system	55.33
[55.160] Front hitch electronic control system.....	55.34
[55.680] Autopilot/Autoguidance	55.35
[55.510] Cab or platform harnesses and connectors.....	55.36
[55.408] Warning indicators, alarms, and instruments	55.37
[55.DTC] FAULT CODES.....	55.38



INTRODUCTION

Safety rules

Personal safety





This is the safety alert symbol. It is used to alert you to potential personal injury hazards. Obey all safety messages that follow this symbol to avoid possible death or injury.

Throughout this manual you will find the signal words DANGER, WARNING, and CAUTION followed by special instructions. These precautions are intended for the personal safety of you and those working with you.

Read and understand all the safety messages in this manual before you operate or service the machine.

 DANGER indicates a hazardous situation that, if not avoided, will result in death or serious injury.

 WARNING indicates a hazardous situation that, if not avoided, could result in death or serious injury.

 CAUTION indicates a hazardous situation that, if not avoided, could result in minor or moderate injury.

FAILURE TO FOLLOW DANGER, WARNING, AND CAUTION MESSAGES COULD RESULT IN DEATH OR SERIOUS INJURY.

Machine safety

NOTICE: Notice indicates a situation that, if not avoided, could result in machine or property damage.

Throughout this manual you will find the signal word Notice followed by special instructions to prevent machine or property damage. The word Notice is used to address practices not related to personal safety.

Information

NOTE: Note indicates additional information that clarifies steps, procedures, or other information in this manual.

Throughout this manual you will find the word Note followed by additional information about a step, procedure, or other information in the manual. The word Note is not intended to address personal safety or property damage.

Basic instructions - Important notice regarding equipment servicing

All repair and maintenance work listed in this manual must be carried out only by qualified dealership personnel, strictly complying with the instructions given, and using, whenever possible, the special tools.

Anyone who performs repair and maintenance operations without complying with the procedures provided herein shall be responsible for any subsequent damages.

The manufacturer and all the organizations of its distribution chain, including - without limitation - national, regional, or local dealers, reject any responsibility for damages caused by parts and/or components not approved by the manufacturer, including those used for the servicing or repair of the product manufactured or marketed by the manufacturer. In any case, no warranty is given or attributed on the product manufactured or marketed by the manufacturer in case of damages caused by parts and/or components not approved by the manufacturer.

The information in this manual is up-to-date at the date of the publication. It is the policy of the manufacturer for continuous improvement. Some information could not be updated due to modifications of a technical or commercial type, or changes to the laws and regulations of different countries.

In case of questions, refer to your CASE IH AGRICULTURE Sales and Service Networks.

SERVICE MANUAL

Engine

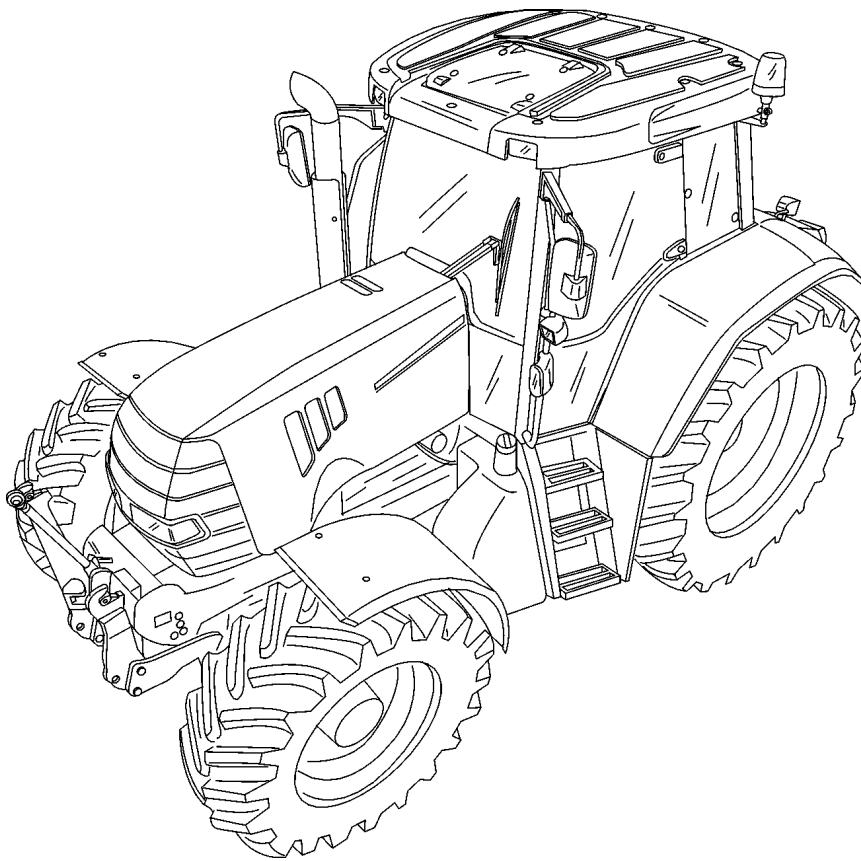

CVX 140
CVX 150
CVX 160
CVX 175
CVX 195

Valve drive and gears - Service instruction

Maintaining the rocker arm system

1. Check the valve tappet, especially the guide face on the camshaft. Replace any worn and bent valve tappets.
2. Check that the push rod is straight. Also check the condition of the spherical faces on the ends of the push rod.

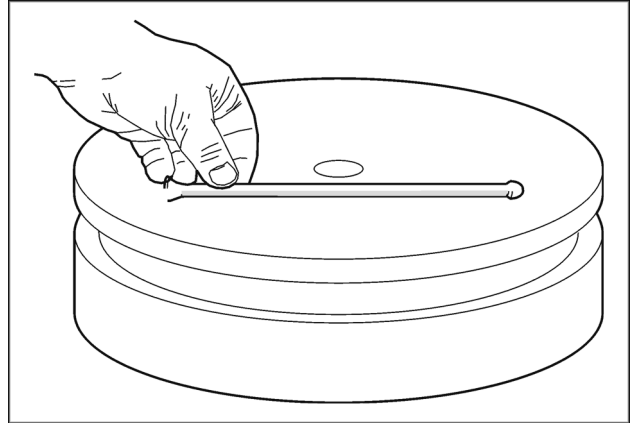

SS05N311 1

3. Dismantle the rocker arm mechanism and clean the individual parts. Check the rocker arm shaft for wear and check the condition of the oil lines.
4. Check the diameter of the bore in the rocker arm (23.000 - 23.021) and replace if necessary. If the rocker arm's pressure face is worn, grind this to the right shape. Do not grind off more than necessary since the pressure face is surface hardened.

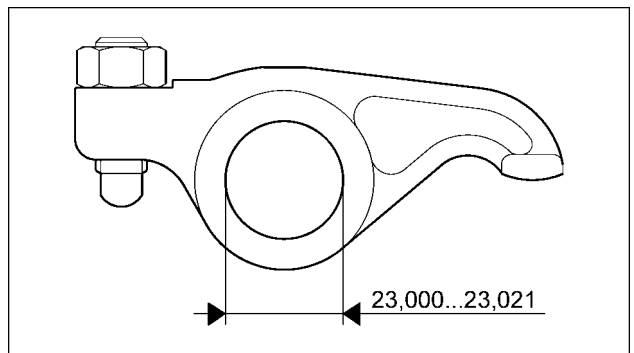

SS05N312 2

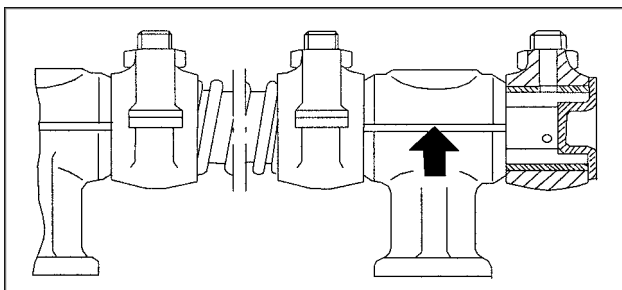

SS99N072 3

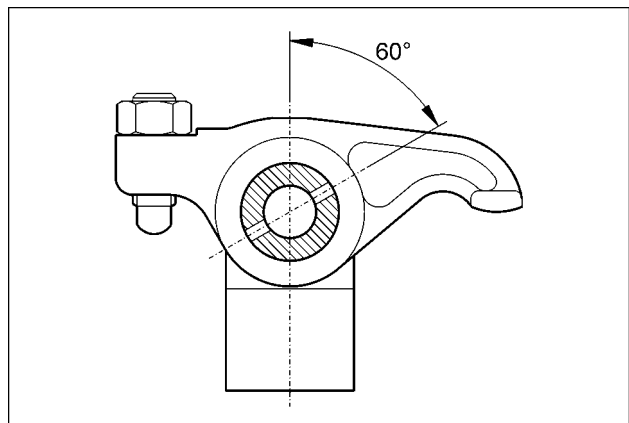

SS05N313 4

5. Secure a flange seal to one end of the rocker arm shaft. Apply oil to shaft and assemble the parts in the correct order. Ensure that the bearing brackets and shaft are positioned correctly. As shown in the diagram, the split half of the bracket and oil bores in the shaft must be facing the valve side. Secure the other flange seal.

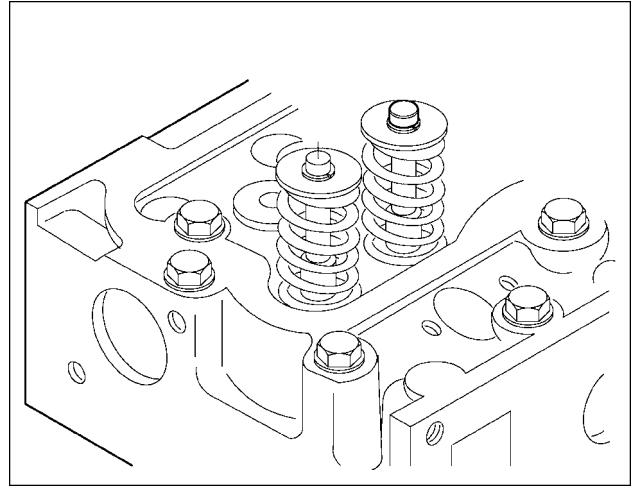

SS06N008 5

Replacing the camshaft / camshaft gear

6. Remove the suction pipe from between the turbocharger and intake manifold. Remove the valve mechanism's cover and bleeder pipe. Remove the rocker arm mechanism.
7. Remove the cooler package, fan, alternator and belts.
8. Remove the pulley and vibration absorber.
9. Loosen the crankshaft nut and remove the hub.
10. Remove the timer case cover.
11. Lock the valve tappets such that they do not fall out when removing the camshaft and prevent the camshaft from being fitted. Lift two neighbouring valve push rods by tilting them a little towards one another. Clamp neighbouring push rods together in pairs (e.g. using an O-ring) such that they are tensioned slightly and the tappet remains in the top position.

ATTENTION: Overtensioning the push rods results in deformations.

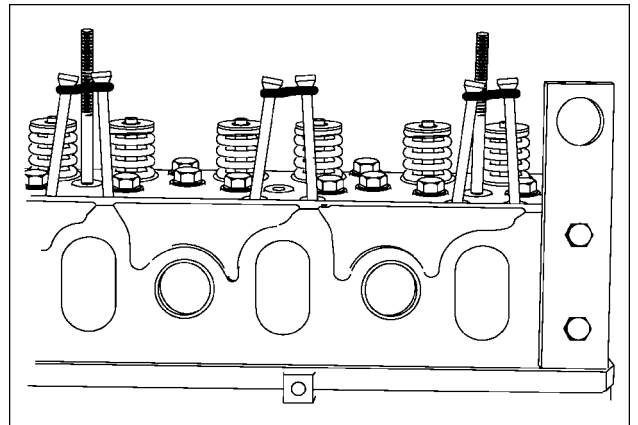

SS05N315 6

12. Rotate the crankshaft such that the position marks on the camshaft gear and intermediate gear meet. Pull out the camshaft.
13. Remove the camshaft gear from the camshaft.
14. If you are refitting the used camshaft or camshaft gear, clean the parts before assembling.
15. Slide the fitting key into the corresponding camshaft groove and fit the camshaft gear. Tighten the nut to **200 Nm**.
16. Lubricate the bearing faces and slide shaft into cylinder block noting the positioning marks of the camshaft gear.

17. Fit timer case cover and pulley with hub. (see **Crankshaft - Service instruction (10.103)**)
18. Lower the push rods and fit the rocker arm mechanism. Set the valves. Then screw the valve cover and ventilation hose onto the cylinder head. Also fit the intake tube which belongs between the turbocharger and intake manifold.
19. Fit the alternator and belts. Tension the belts to the correct tension. Fit the cooler package.

Checking and setting the valve clearance

The valve clearance of the inlet and outlet valve is **0,35 mm**. The check can be undertaken when the engine is cold and warm. Check and regulate the valve clearances of a cylinder when the piston is in the upper top dead centre of the compression stroke. Proceed in the order of engine fuel injection.

If the valve clearance deviates from the specified value, loosen the lock nut and correctly set the valve clearance with the setting screw. The **0,35 mm** feeler gauge must fit tightly between the rocker arm and valve shaft end.

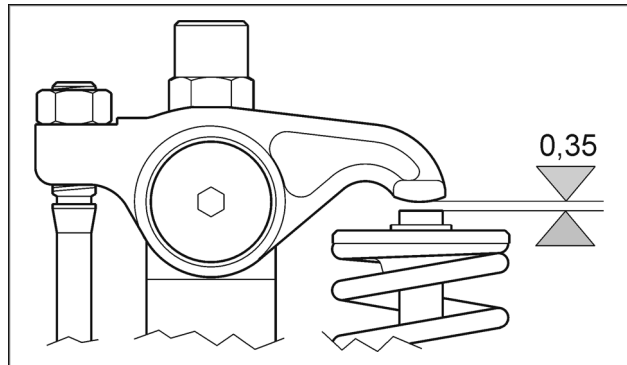

SS05N314 7

- Turn the crankshaft in the direction of travel until the valves of the 6th cylinder are overlapping. (outlet valve is closed, inlet valve is open). Check the valves of the first cylinder.
- Turn the crankshaft 1/3rd of a revolution in the direction of travel such that the valves of the 2nd cylinder overlap. Check the valves of the 5th cylinder.
- Continue your work in the order of fuel injection:

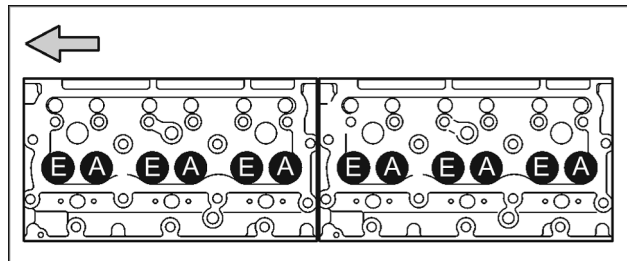

SS05N317 8

Injection sequence:	1 - 5 - 3 - 6 - 2 - 4
Valve overlap:	6 - 2 - 4 - 1 - 5 - 3

Camshaft gear - Service instruction (timing gears)

Timing gear case removal

The timing gear case protects the components against leaks originating in the oil pan. For this reason, the timing box can only be removed once the oil pan has been taken out.

1. Drain the engine oil and remove the oil pan.
2. Remove the ventilator, alternator, pulley and belt. If the tractor is fitted with an air-conditioning or compressed air system, the compressor must also be removed.
Key for viscous fan: **380001791**
Key for reversible fan: **380002657**

NOTICE: Do not disconnect the refrigerant lines! When the lines are connected, only tilt the air-conditioning compressor backwards. Hang the compressor up to avoid straining the lines.

3. Remove the pulley and vibration damper.
4. Loosen the crankshaft nut using key **380002658**.
5. Loosen the mounting bolt for the double idler bearing.
6. Lift off the timing gear case cover and remove the oil seal ring from the crankshaft.
7. Remove the high-pressure fuel pump. Refer to **High pressure pump - Remove (10.218)**.
8. Remove the double idler gear.
9. Unscrew the idler gear screws. Remove the flange, tooth gear and bearing journal.
10. Remove the camshaft.

NOTE: If the cylinder head and valve mechanism are not being removed, the valve tappets must be prevented from falling off. (Refer to **Valve drive and gears - Service instruction (10.106)**).

11. Unscrew the screws from the timing gear case and remove it. If a soft wedge needs to be placed between the engine block and gear case, ensure that you do not damage the sealing surfaces!
12. Remove the foremost crankshaft sealing ring from the gear case and clean all the parts that have been removed.

Replacing the idler gear bearing bush

When replacing the idler gear bearing bush, ensure that the new bearing bush is inserted so that its rear edge is positioned **0.1 - 0.25 mm (0.004 - 0.010 in)** inside the rear gear wheel edge (refer to diagram).

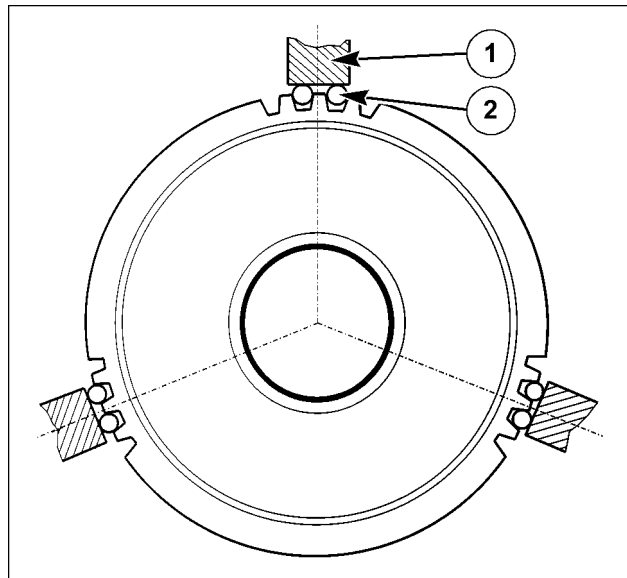

1. Lathe chuck
2. Roller $\varnothing = 5 \text{ mm (0.20 in)}$

After installation, machine the inside diameter of the idler gear bearing bush to the correct dimensions. Centre the idler gear as shown in the diagram above so that the backlash is maintained at a constant level.

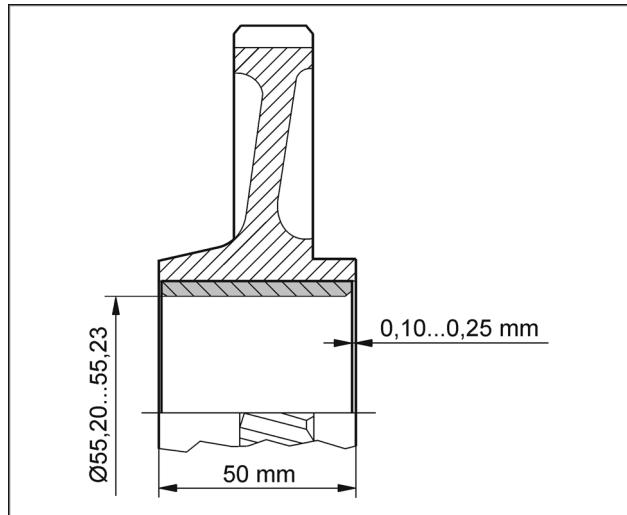

Installing the timing gear case

The position of the timing gear case and the cover is determined by two roll pins. Centring should therefore not be performed as part of the installation, but it is necessary to check the free play between the various tooth gears. The timing gear case and cover supplied as spare parts are already equipped with pre-processed bores for the roll pins.

13. Seal the timing gear case with surface sealant and fit it on the cylinder block. Use a mandrel to drive in the roll pins. Tighten the bolts and nuts.
14. Lubricate the camshaft bearing and insert the shaft into the cylinder block. If the push rods and valve tappets were suspended, release them.

15. Install the idler gear with the shaft stud bolt and ensure that the markings are properly aligned. Add the washer and tighten the bolts to the correct torque.

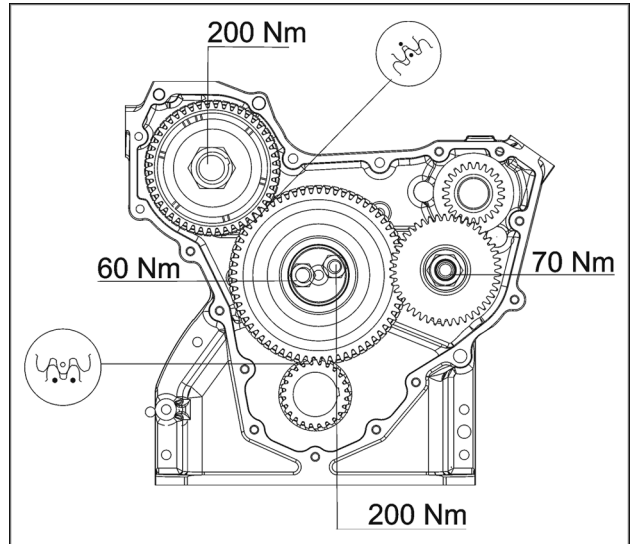

SS05N365 3

16. Place the angular ball bearing in the double idler gear. Fit the idler gear in the gear case using the mounting bolt.

NOTE: Use new O-rings!

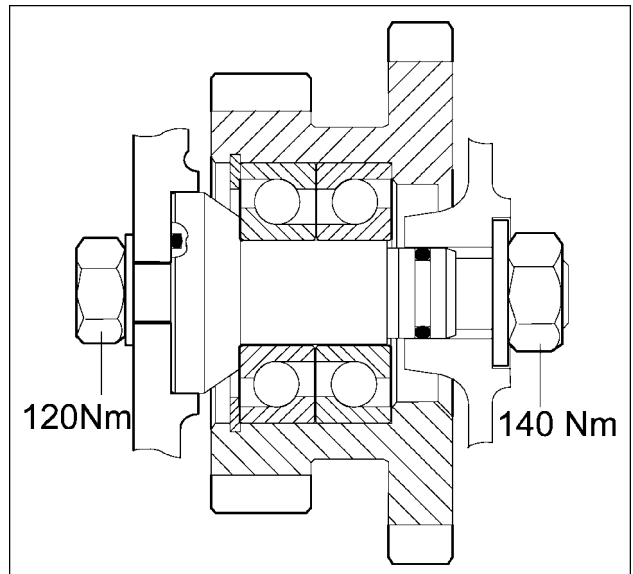

SS05N364 4

17. Check the backlash. The backlash must be between **0.05 - 0.25 mm (0.002 - 0.010 in)**.

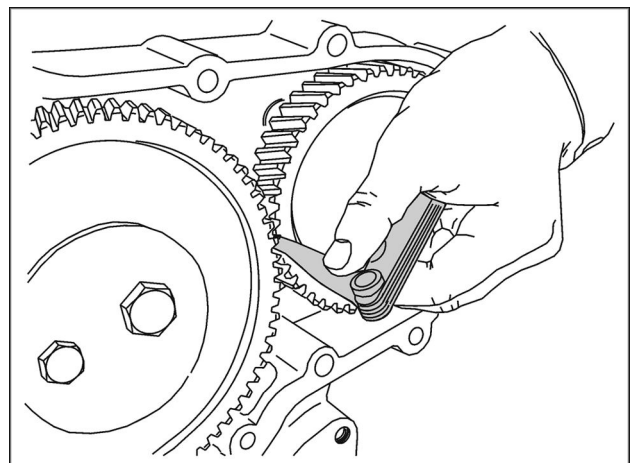

SS05N338 5



Suggest:

If the above button click is invalid.

Please download this document

first, and then click the above link

to download the complete manual.

Thank you so much for reading

18. Place the oil seal ring onto the crankshaft and fit the gear case cover using a new seal. Drive the roll pins in using a mandrel (assemble the tubing around the stud). Tighten the bolts and nuts to the correct torque.

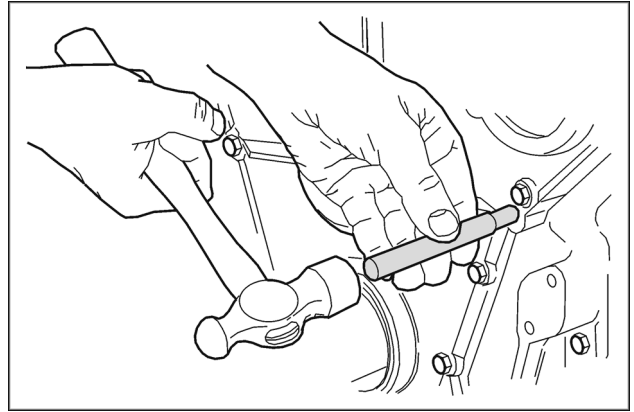

SS05N339 6

19. Correctly position the guard ring in the seal seat (refer to diagram 8) and install the foremost crankshaft seal ring using special tool 380000002, pushing it up to the stops.

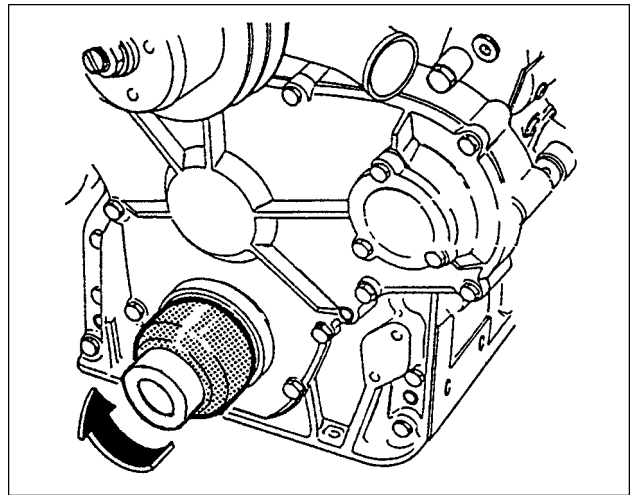

SS99N114 7

20. Lubricate the sealing surfaces of the sealing ring and crankshaft. Also lubricate the hub fixture profile.

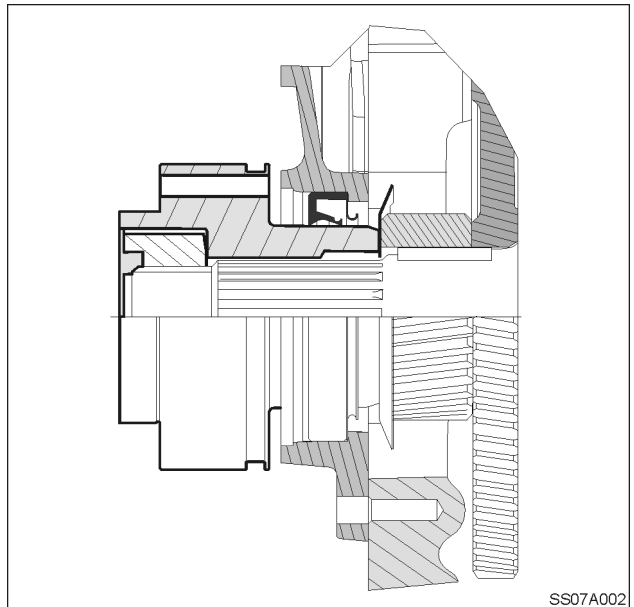

SS07A002
SS07A002 8

<https://www.ebooklibonline.com>

Hello dear friend!

Thank you very much for reading.

Enter the link into your browser.

The full manual is available for immediate download.

<https://www.ebooklibonline.com>