

1. Trim along dashed line.
2. Slide into pocket on Binder Spine.

TYPE 1-4

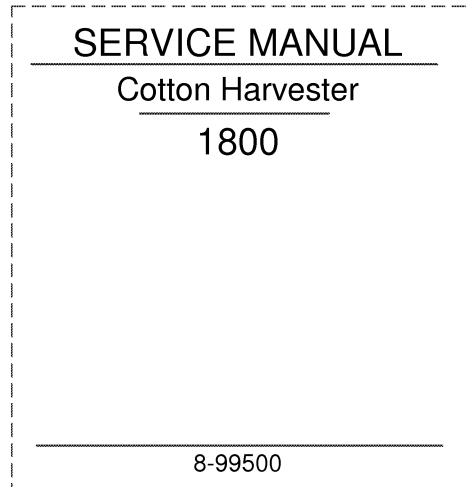

1. Trim along dashed line.
2. Slide into pocket on Binder Spine.

TYPE 1-4

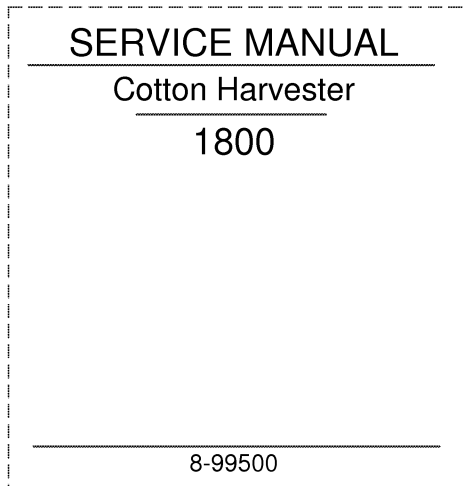

1. Trim along dashed line.
2. Slide into pocket on Binder Spine.

TYPE 1-4

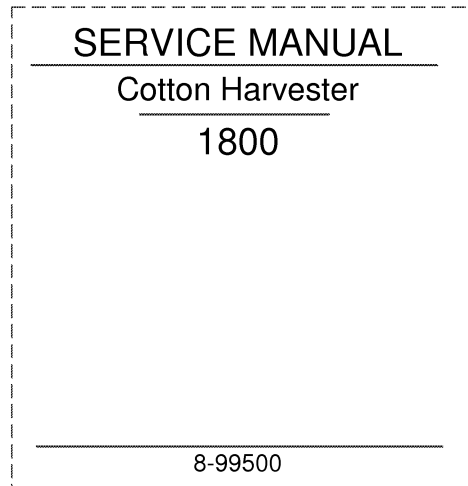

1. Trim along dashed line.
2. Slide into pocket on Binder Spine.

TYPE 1-4

1800 Cotton Harvester
Service Manual

Table of Contents

Description	Section No.	Form No.
General	Tab 1	
Loctite Product Chart		8-98900
Engine 6-590 Case	Tab 2	
Engine Specifications - 6-590	2401	8-26063
Cylinder Head and Valve Train	2415	8-26073
Cylinder Block	2425	8-26084
Lubrication System	2445	8-26093
After Cooler	2545	8-26120
Cooling System	2455	8-26103
Turbocharger	2465	8-26110
Turbocharger - Failure Analysis	2565	9-78235
Fuel System 6-590 Case Engine	Tab 3	
Fuel System and Filters	3410	8-26131
Fuel Injection Pump	3411	8-97711
Fuel Injectors	3413	8-26152
Electrical	Tab 4	
Wiring Schematics and Troubleshooting	4001	8-97730
Instrument Cluster Troubleshooting	4011	8-62520
Battery Service and Testing	4235	8-20291
Starter Motor	4011	8-95970
Alternator	4004	8-91792
Neutral Start Switch	4070	8-62271
Steering	Tab 5	
Steering System Testing	5010	8-62420
Steering Column and Hand Pump	5021	8-98040
Steering Cylinder	5030	8-62440
Steering Axle	5040	8-62450
Power Train	Tab 6	
Hydrostatic Propulsion Troubleshooting	6010	8-62380
Foot-N-Inch Valve	6015	8-62550
Hydrostatic Drive Pump Removal and Installation	6017	8-62280
Hydrostatic Drive Pump	6018	7-34820
Hydrostatic Drive Motor	6030	8-62472
Transmission Removal and Installation	6035	8-98980
Transmission Service	6040	8-62391
Final Drive and Pinion Assembly	6060	8-62201
Brakes	Tab 7	
Service and Parking Brake	7010	8-62211
Brake Valve and Cylinders	7020	8-62241

1800 Cotton Harvester
Service Manual

Table of Contents

Description	Section No.	Form No.
Hydraulic	Tab 8	
Hydraulic Schematics and Troubleshooting	8001	8-97740
Hydraulic Oil Filters	8031	8-98730
Hydraulics Pump Removal and Installation	8035	8-99170
Hydraulic Pump and Compensator	8040	8-62480
Electro Hydraulic Valves	8050	8-98680
Hydraulic Valves, Cylinders and Motors	8060	8-99040
Accessories	Tab 9	
Servicing the Air Conditioner Compressor Sanden Model SD 508HD	9000	7-35200
Air Conditioner Troubleshooting	9001	7-35210
Air Conditioner System Gauges and Testing	9002	7-37680
Air Conditioner System Service, Recovery, Evacuation and Recharting	9003	7-34860
Air Conditioner Components Service for Systems with Sanden Compressor	9004	7-34890
Servicing the Cab Blower	9050	8-62300
Operator Seat	9060	8-62310
Fan Assembly	9070	8-98740
Basket Assembly Service	9075	8-99180
Cross Auger Header and Brush Roll Units	9090	8-98630

<https://www.ebooklibonline.com>

Hello dear friend!

Thank you very much for reading.

Enter the link into your browser.

The full manual is available for immediate download.

<https://www.ebooklibonline.com>

SPECIAL TORQUES

	Metric Value
Alternator Bracket Bolts	21 to 27 Nm
Belt Tensioner Bolt	39 to 47 Nm
Belt Tensioner Bracket Bolt (Allen head)	21 to 27 Nm
Cylinder Head Bolts (Short)	90 Nm Plus 90 Degrees
Cylinder Head Bolts (Long)	120 Nm Plus 90 Degrees
Exhaust Manifold Bolts	39 to 47 Nm
Fan Belt Pulley Bracket Bolts	23 to 25 Nm
Fan Belt Pulley Bolts	
Grade 8.8 Size M8	26 to 31 Nm
Grade 10.9 Size M8	37 to 43 Nm
Grade 8.8 Size M10	51 to 62 Nm
Grade 10.9 Size M10	51 to 62 Nm
Filter Inlet Fitting	29 to 35 Nm
Fuel Filter Housing Nut	29 to 35 Nm
Injector Cap Nut	55 to 65 Nm
Injector Leak Off Fitting	5 to 7 Nm
Intake Manifold Cover Bolts	21 to 27 Nm
Lift Bracket Bolt (Rear)	71 to 83 Nm
Rocker Arm Bracket Bolts	21 to 27 Nm
Thermostat Housing Bolts	21 to 27 Nm
Valve Cover Bolts	21 to 27 Nm

SPECIAL TOOLS



CAS-1743 VALVE GUIDE REAMER
SEE PAGE 15

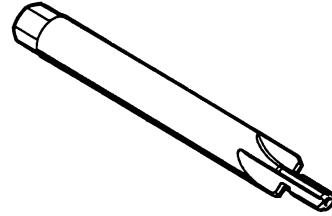

CAS-1694 9 mm INJECTION BORE CLEANER
CAS-2155 7 mm INJECTION BORE CLEANER
SEE PAGE 29

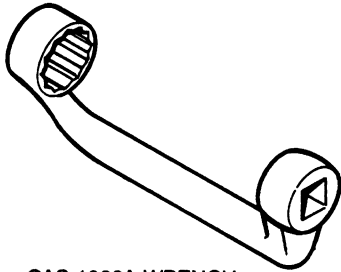

CAS-1066A WRENCH
SEE PAGE 8

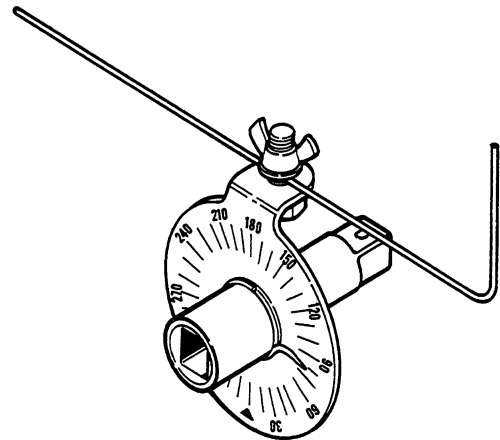

CAS-2162 TORQUE ANGLE GAUGE
SEE PAGE 33

SERVICING THE CYLINDER HEAD AND VALVE TRAIN

Cylinder Head Removal

STEP 1

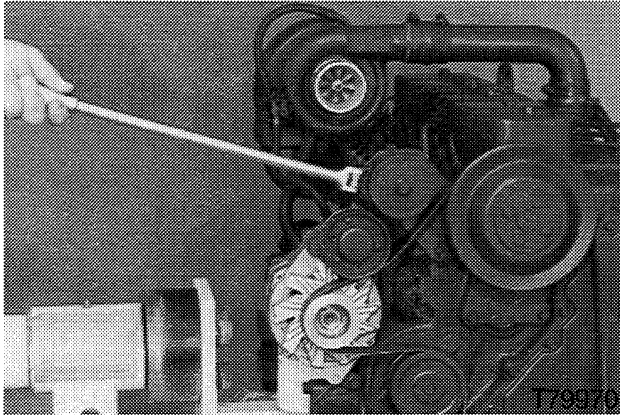

Lift the belt tensioner and remove the fan belt.

STEP 4

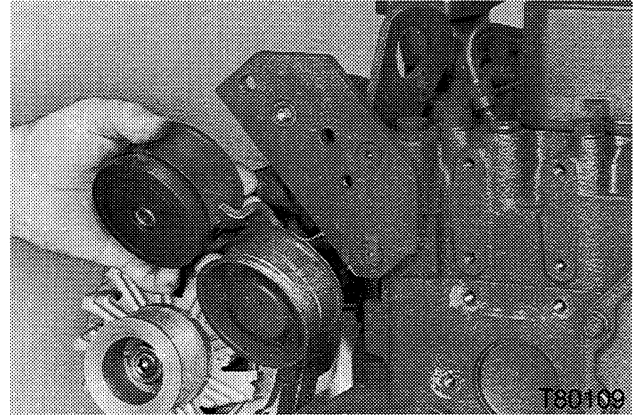

Remove the belt tensioner bolt and the belt tensioner.

STEP 2

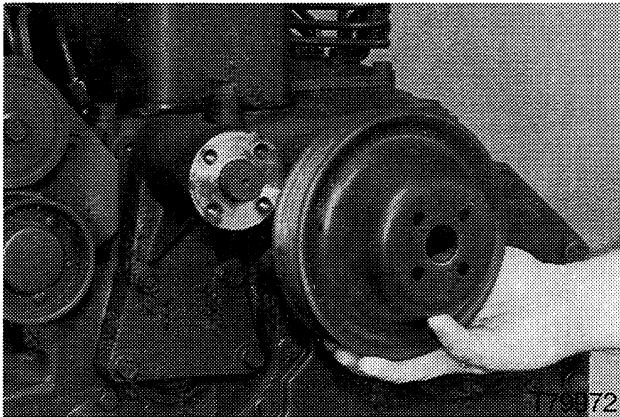

Remove the fan pulley bolts and the fan pulley.

STEP 5

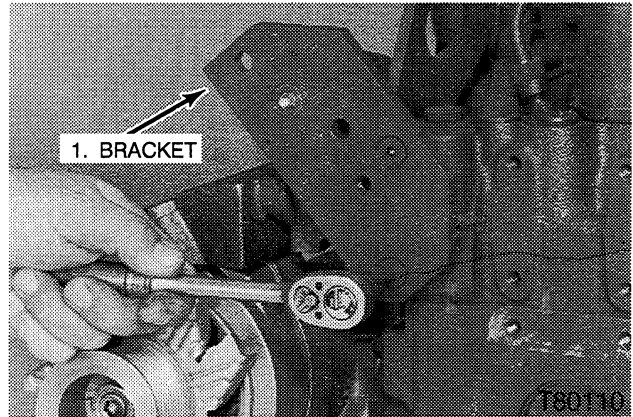

Remove the Allen head bolts and the belt tensioner bracket.

STEP 3

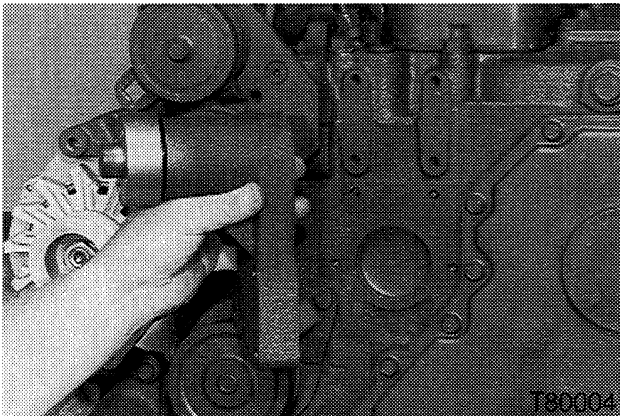

Remove the fan pulley bolts and the pulley bracket.

STEP 6

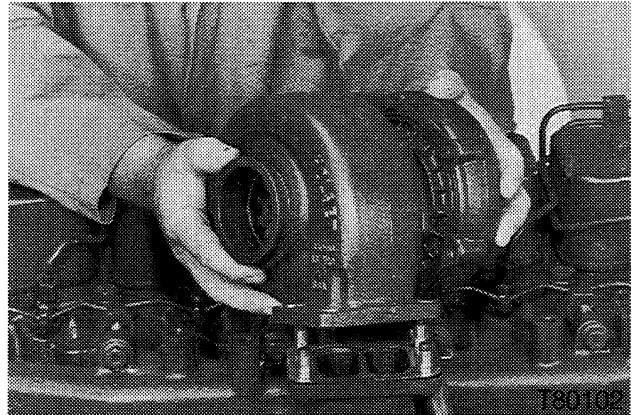

See section 2465 to remove the turbocharger.

STEP 7

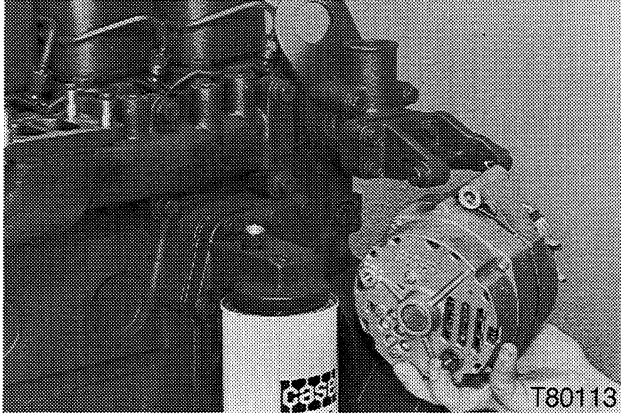

Remove the bolts that hold the alternator and remove the alternator.

STEP 8

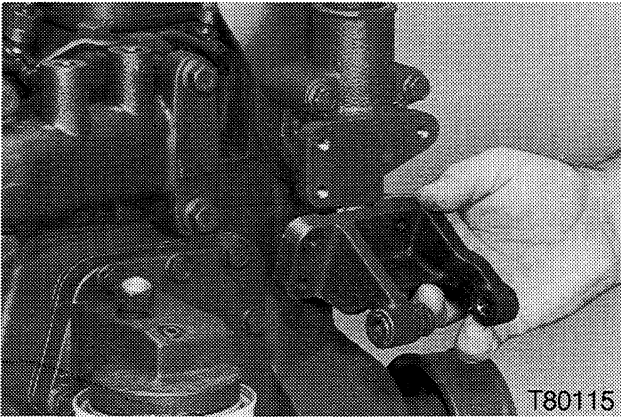

Remove the bolts and the alternator bracket.

STEP 9

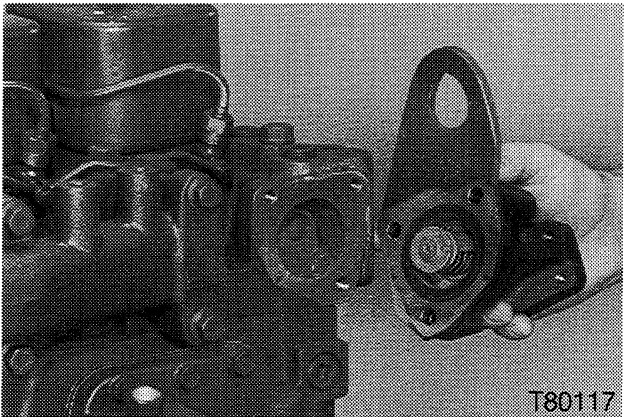

Remove the bolts and the thermostat housing assembly.

STEP 10

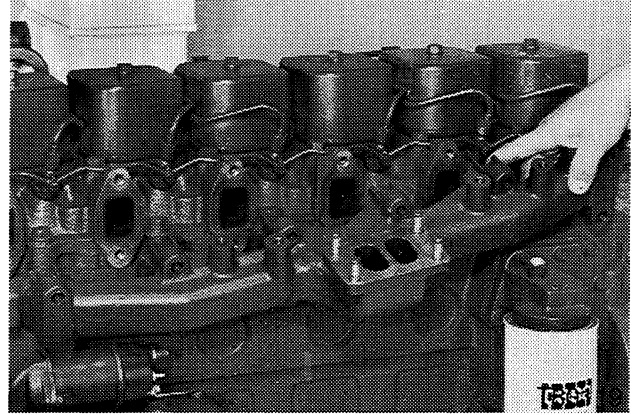

Remove the bolts and the exhaust manifold.

STEP 11

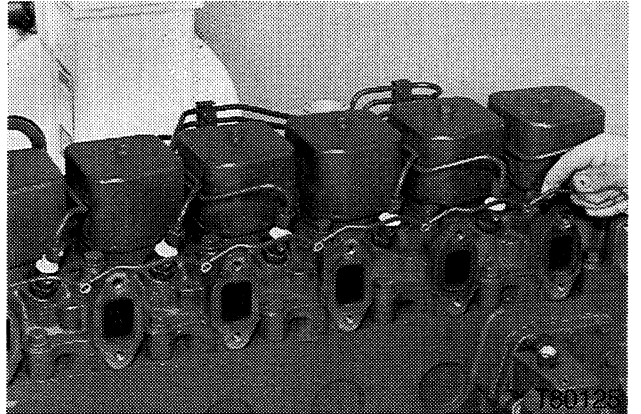

Remove the leak off fittings, gaskets and the leak off line.

STEP 12

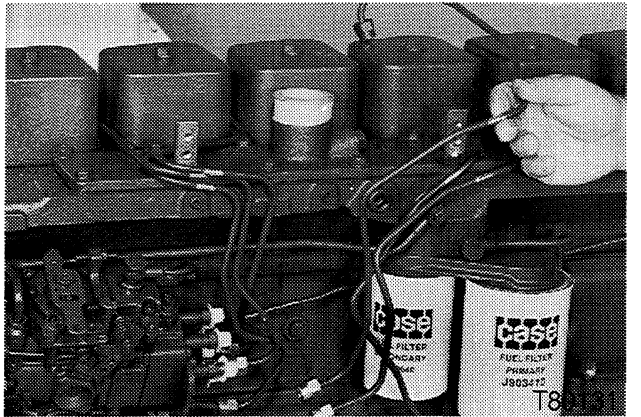

Disconnect and remove the fuel lines. Install protective covers on the injector pump and the fuel lines.

STEP 13

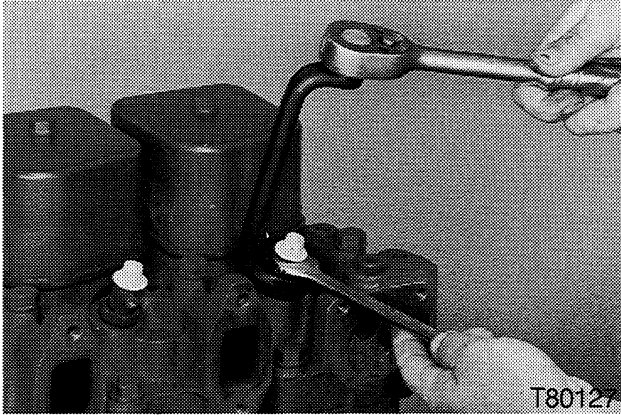

Loosen the nut on the injectors.

NOTE: *The injector must not rotate in the bore of the cylinder head. This will damage the cylinder head.*

STEP 14

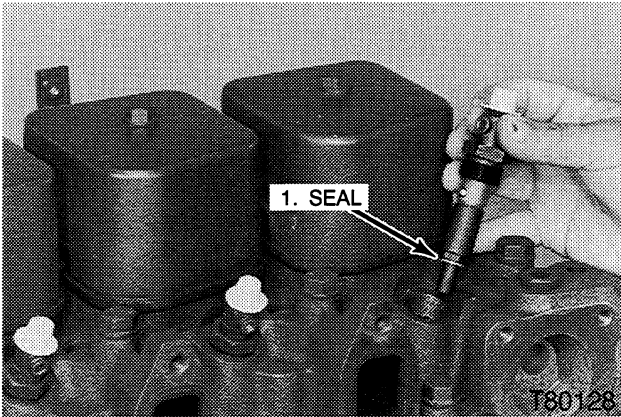

Remove the injectors from the cylinder head.

NOTE: *Make sure the injector seal is removed from the cylinder head.*

STEP 15 BOSCH INJECTION PUMP

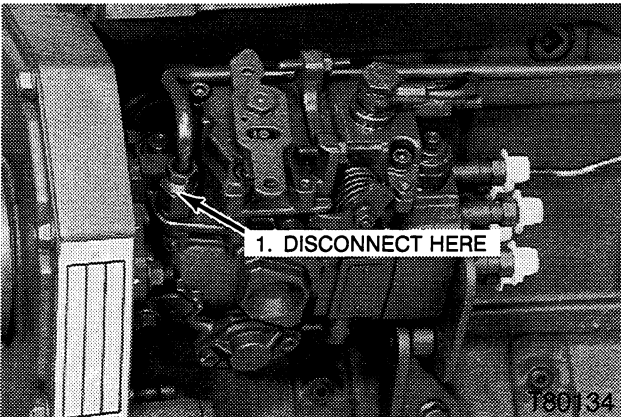

Disconnect the injection pump inlet line and remove the inlet line.

STEP 16 CAV INJECTION PUMP

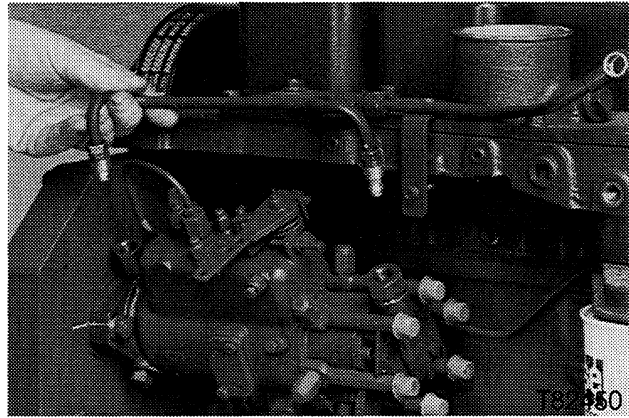

Disconnect the injection pump inlet line and remove the inlet line.

STEP 17 CAV INJECTION PUMP

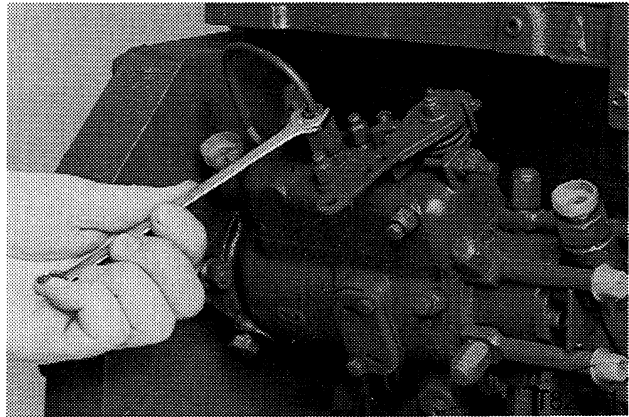

Disconnect the leak off line.

STEP 18



Disconnect and remove the fuel line.

STEP 19



Use a strap wrench to remove the fuel filters.

STEP 22

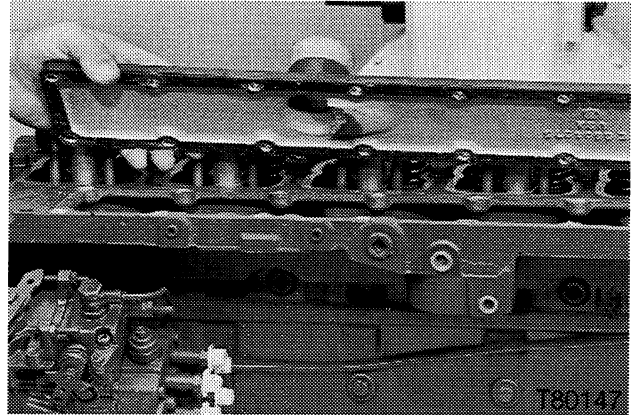

Remove the intake manifold bolts and the intake manifold cover.

STEP 20

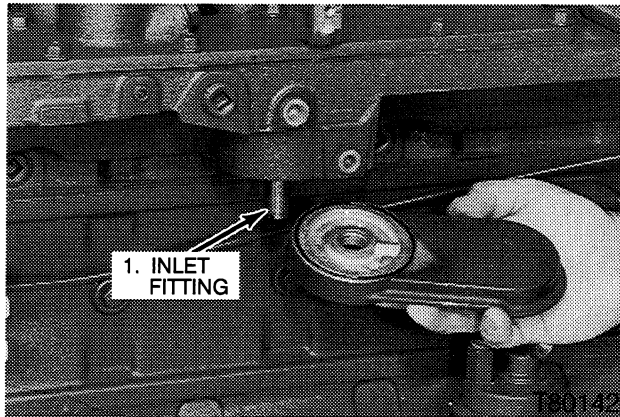

Remove the fuel filter housing and the inlet fitting.

STEP 23

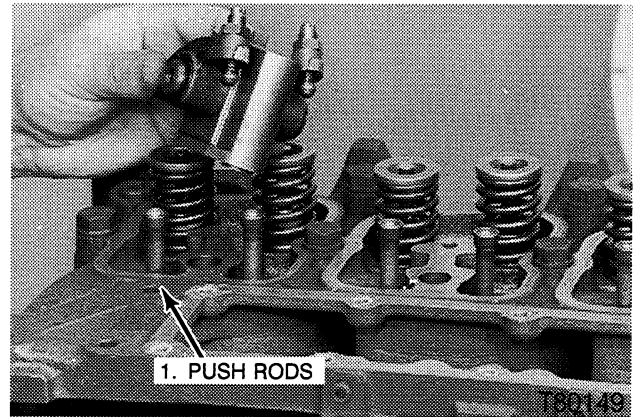

Remove the rocker arm bolts, rocker arm assemblies and the push rods.

STEP 21



Remove the valve cover bolts and the valve covers.

STEP 24

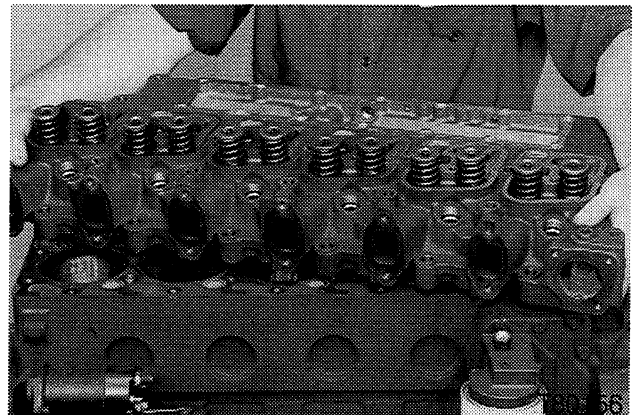

Remove the cylinder head bolts and the cylinder head.

STEP 25

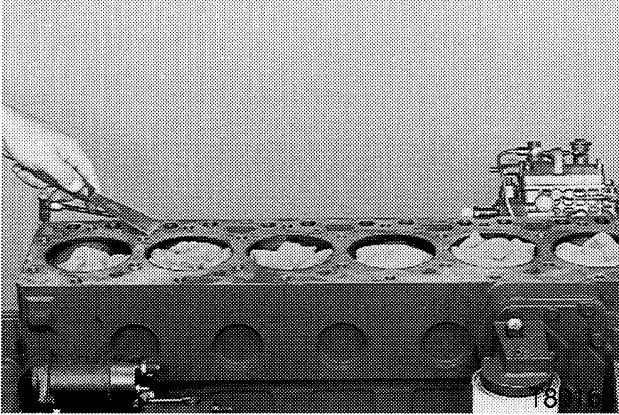

Cover the cylinder bores and pistons. Clean all foreign material from the cylinder head mounting surface.

NOTE: *The cylinders and pistons must be covered to prevent damage to the pistons and cylinder walls.*

Cylinder Head Disassembly

STEP 26

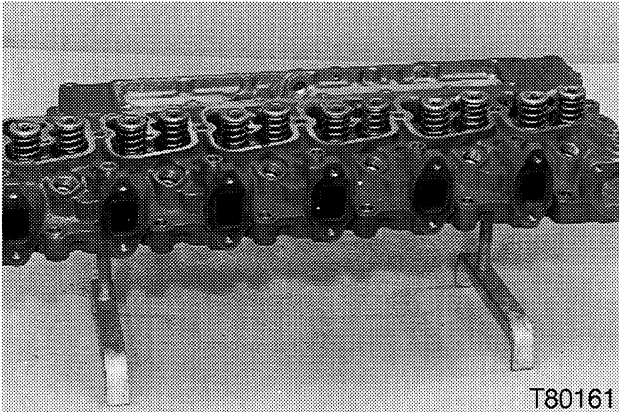

Put the cylinder head on a clean work surface.

STEP 28

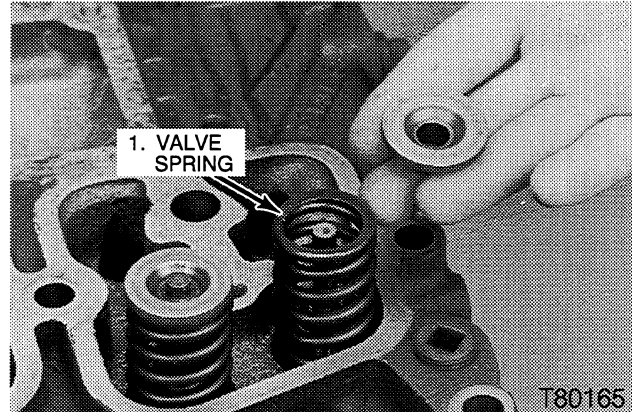

Remove the valve spring retainers and the valve spring.

STEP 27

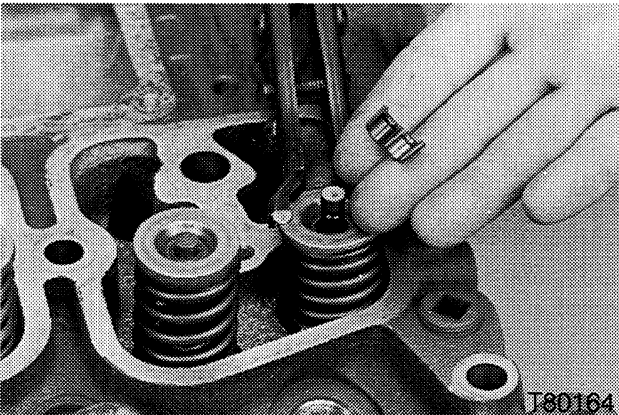

Use a valve spring compressor to push down the valve springs and remove the valve keepers.

STEP 29

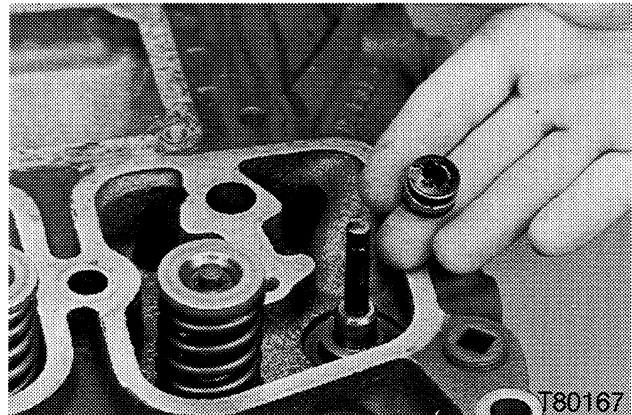

Remove the valve seals.

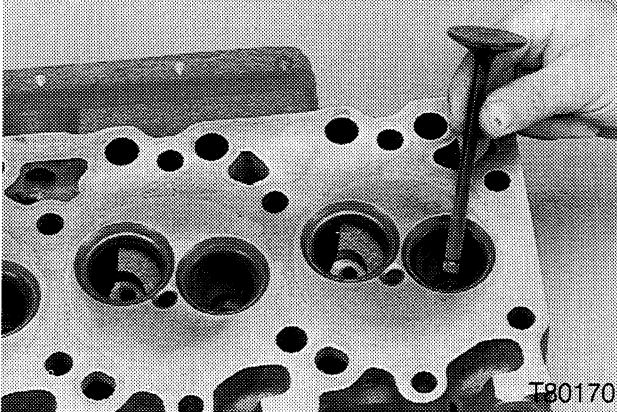
STEP 30

Remove the valves.

IMPORTANT: Using paint, make a mark on the valves, keepers and retainers. This will make sure the parts are installed in the original location.

CHECKING AND RESURFACING THE CYLINDER HEAD

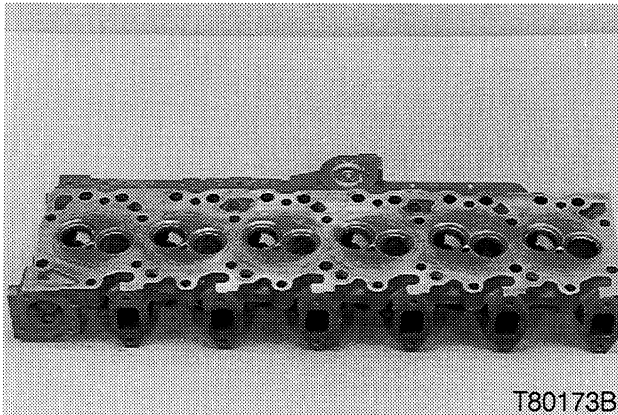
STEP 31

Clean the cylinder head completely, removing carbon and other deposits. Check for cracks and any sign of damage in the area of the fire ring contact.

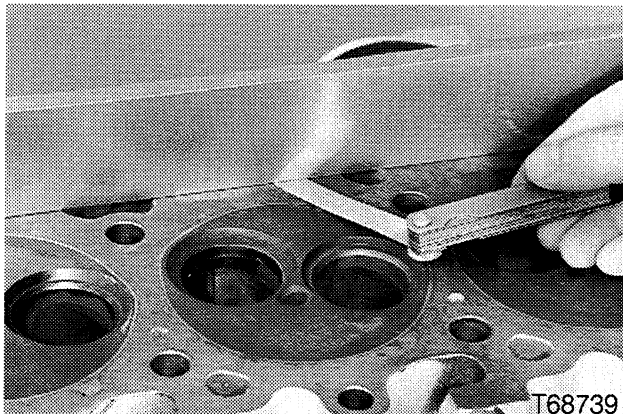
STEP 32

Check the cylinder head surface with a straight edge and feeler gauge. Resurface the cylinder head if warpage or erosion is more than 0.010 mm in any 50 mm diameter area or if there is more than 0.075 mm overall end to end or side to side.

Rac 8-26073

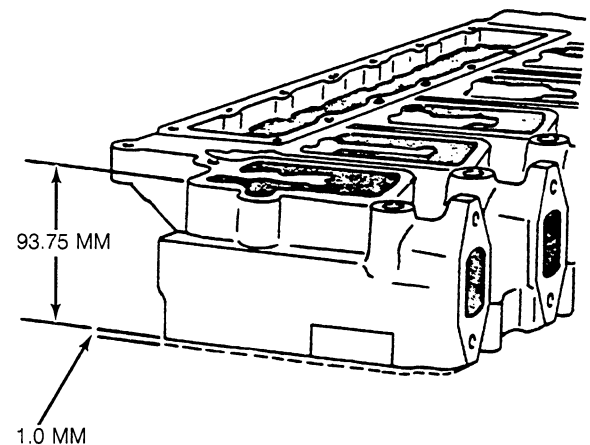
STEP 33

Resurface the cylinder head in increments necessary to straighten the surface and maintain surface finish according to the following specifications:

- A = 1.0 mm total amount of material removed.
- B = 93.75 to 94.25 mm minimum total height of the cylinder head.
- C = Surface finish 0.5 to 3.2 micrometers.
- D = Use this area to stamp the total thickness of cylinder head material removed in mm.

STEP 34

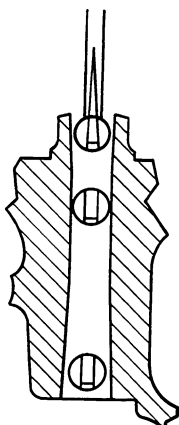
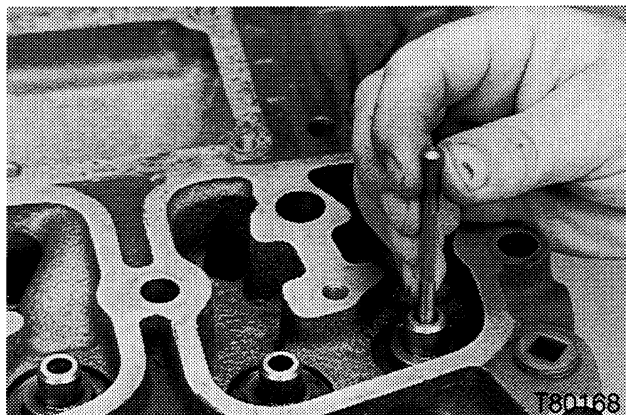

898L0

Check the valve guides in three positions with a bore gauge.

STEP 35

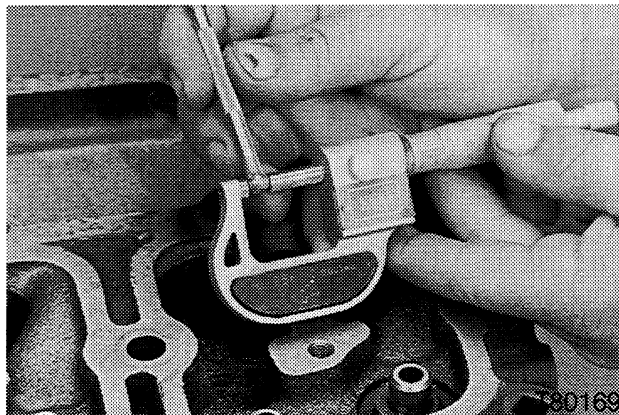

Check the bore gauge with a micrometer.

NOTE: *If the diameter is more than 8.089 mm, a valve guide must be installed.*

EXPANSION PLUG REMOVAL AND INSTALLATION

STEP 36

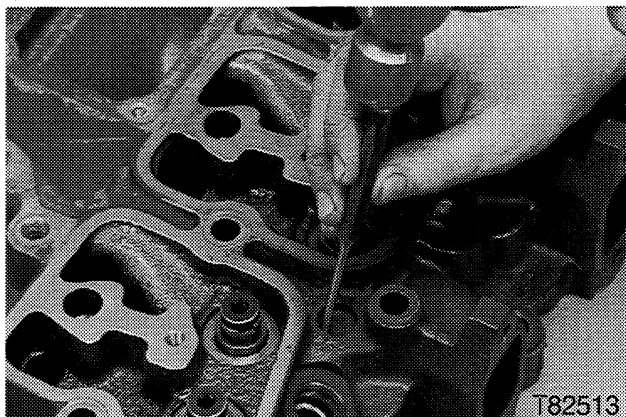

Remove the expansion plug from the cylinder head.

STEP 37

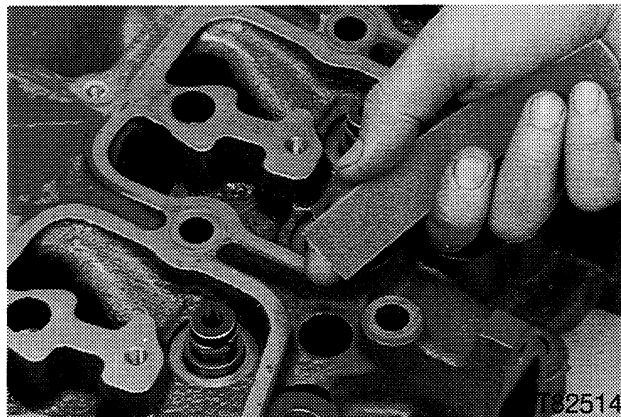

Clean the sealing surface of all foreign material.

STEP 38

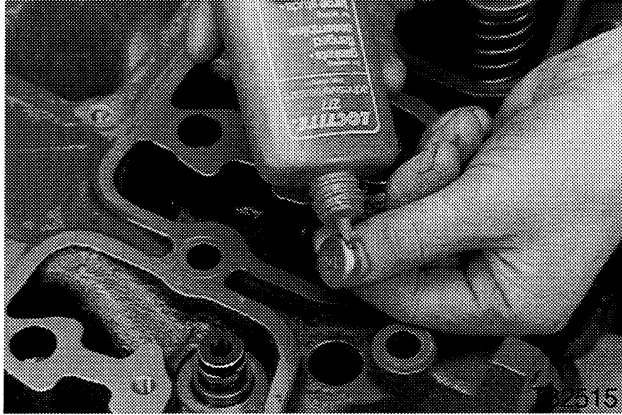

Apply Loctite 277 to the sealing surface of the expansion plug.

STEP 39

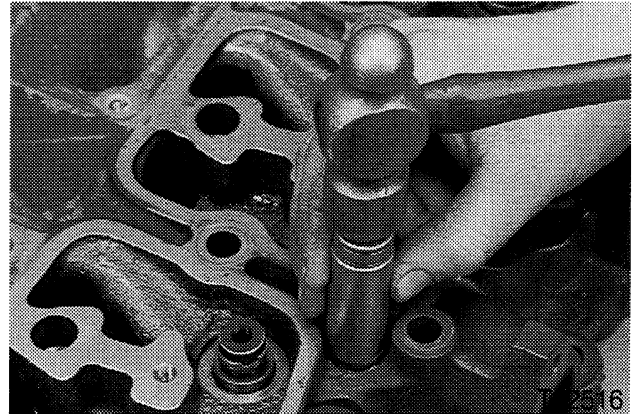
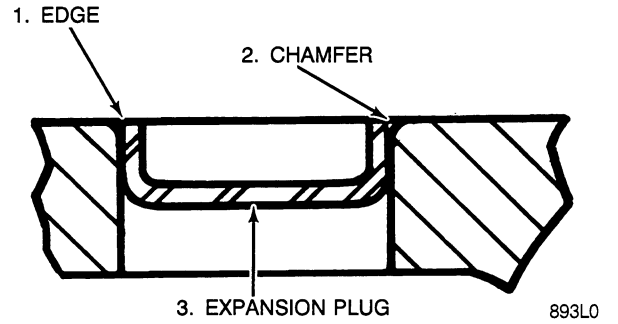

Install the expansion plug into the cylinder head until the top edge of the expansion plug is even with the bottom edge of the chamfer.

VALVE GUIDE REPLACEMENT 14 mm Replacement Valve Guides

There are two different diameters of replacement valve guides for your engine. You can get either 14 mm or 11 mm OD replacement valve guides. Measure the replacement valve guides before you machine the cylinder head.

Specifications

Valve guide OD 14.026 to 14.038 mm
 Bore cylinder head to 13.987 to 14.013 mm
 Installed height above top of valve guide boss on cylinder head 11.25 to 11.75 mm

STEP 40

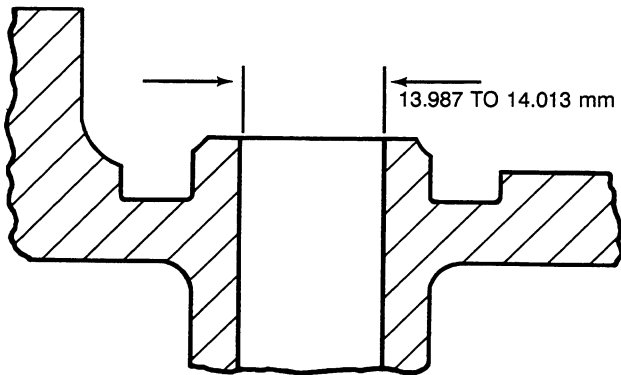
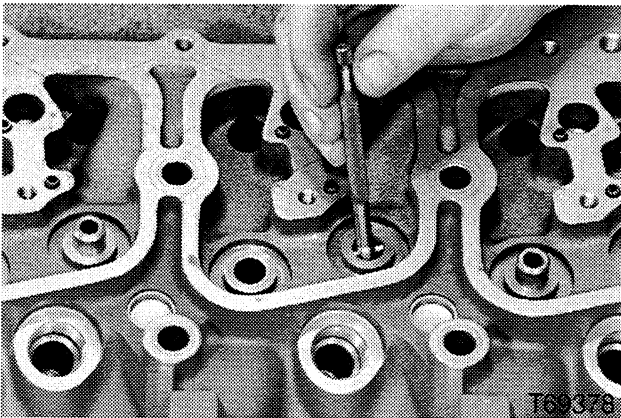

Drill the valve guide bores to 13.987 to 14.013 mm diameter.

STEP 41

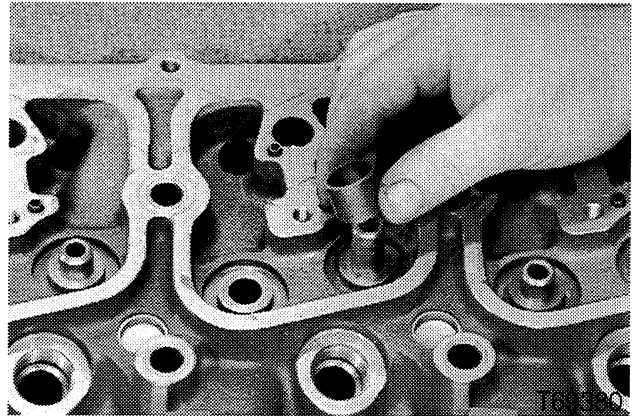

1. SURFACE OF CYLINDER HEAD 2. TOP OF VALVE GUIDE

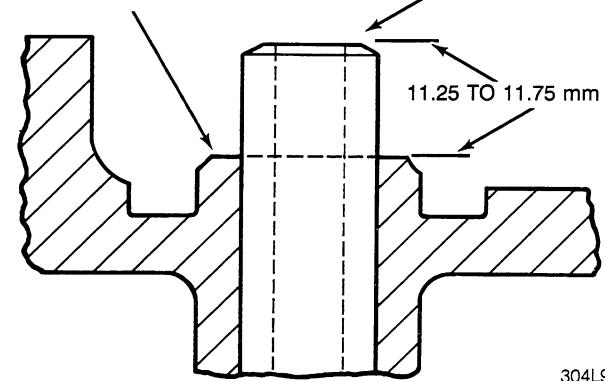

Make a bushing 16.038 mm ID x 11.25 to 11.75 mm long. Install the bushing over the new valve guide. Press the new valve guide into the cylinder head until the press contacts the bushing.

STEP 42

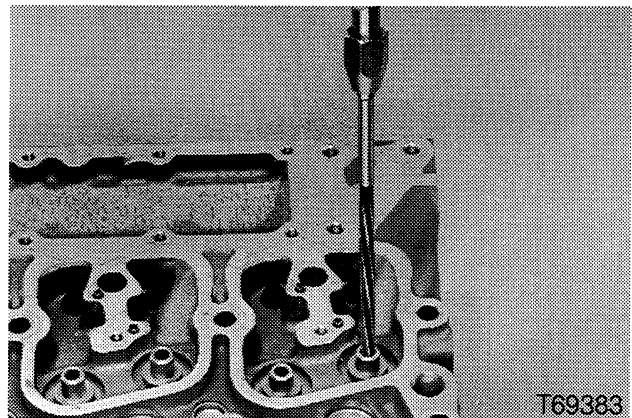

Drill the new valve guides to a diameter of 8.0 mm. Ream the new valve guides to a finished diameter of 8.019 to 8.039 mm.



Suggest:

If the above button click is invalid.

Please download this document

first, and then click the above link

to download the complete manual.

Thank you so much for reading

11 mm Replacement Valve Guides

Specifications

- Valve guide OD 11.150 to 11.163 mm
- Bore cylinder head to 11.112 to 11.138 mm
- Installed height above top of valve guide boss on cylinder head 11.25 to 11.75 mm

STEP 43

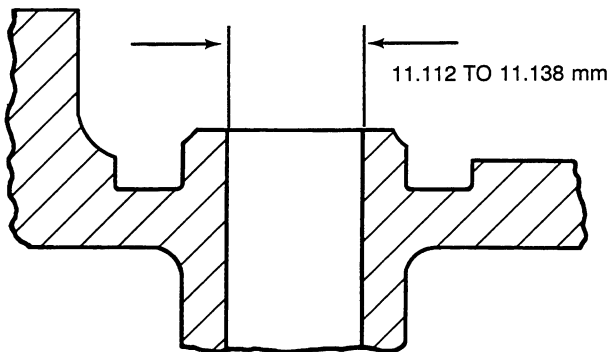
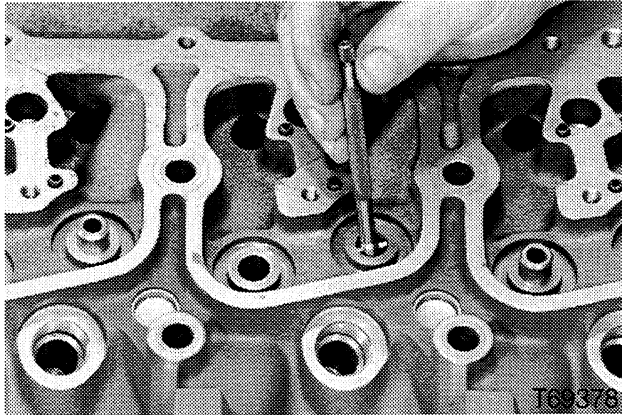

303L91

Drill the valve guide bores to 11.112 to 11.138 mm diameter.

STEP 44

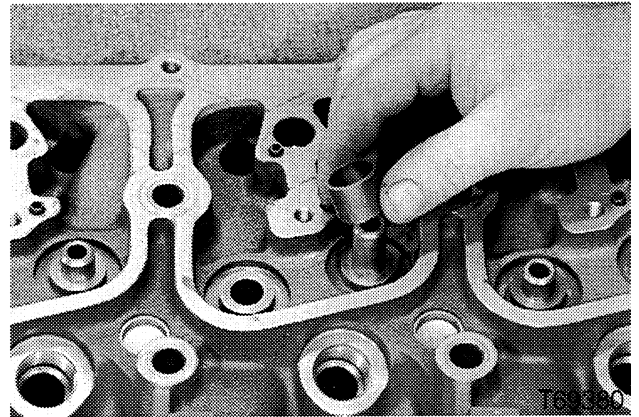

- 1. SURFACE OF CYLINDER HEAD
- 2. TOP OF VALVE GUIDE

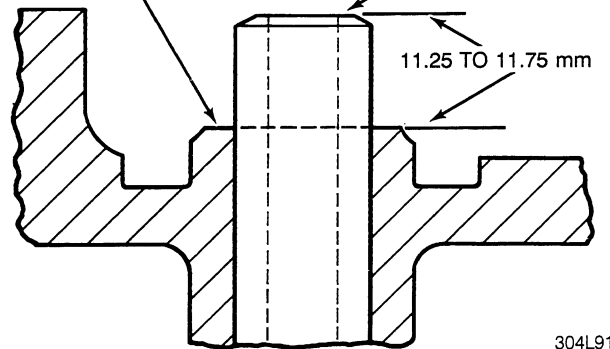

304L91

Make a bushing 16.038 mm ID x 11.25 to 11.75 mm long. Install the bushing over the new valve guide. Press the new valve guide into the cylinder head until the press contacts the bushing.

STEP 45

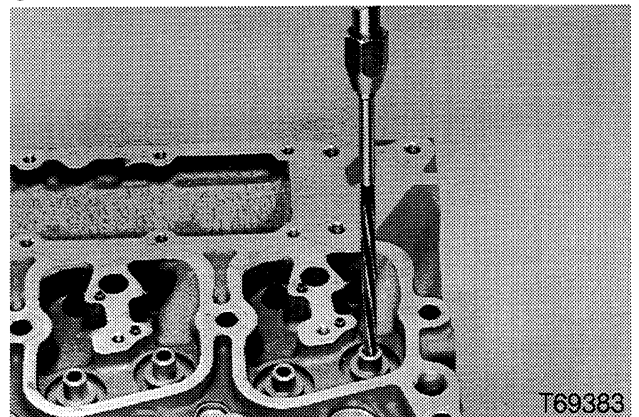

Drill the valve guides to a diameter of 8.0 mm. Ream the new valve guides to a finished diameter of 8.019 to 8.039 mm.

<https://www.ebooklibonline.com>

Hello dear friend!

Thank you very much for reading.

Enter the link into your browser.

The full manual is available for immediate download.

<https://www.ebooklibonline.com>