

# 1187C Excavator

## Table of Contents

DIVISION/SECTION	SECTION NO.	FORM NO.
<b>1 GENERAL</b>		
Section Index - General .....		8-74860
Standard Torque Specifications.....	1001	8-71600
Fluids and Lubricants .....	1002	8-74870
Detailed Engine Specifications .....	1426	8-28421
<b>2 ENGINES</b>		
Section Index - Engines .....		8-74880
Engine Removal and Installation and Radiator Removal and Installation .....	2001	8-74890
Stall Tests .....	2002	8-74910
After Cooler System .....	2011	8-91700
Cylinder Head and Valve Train .....	2415	8-28430
Cylinder Block .....	2425	8-28440
Lubrication System.....	2445	8-28450
Cooling System .....	2455	8-28460
Turbocharger.....	2465	8-28470
Turbocharger Failure Analysis .....	2565	9-78235
<b>3 FUEL SYSTEM</b>		
Section Index - Fuel System .....		8-74920
Fuel System and Filters .....	3410	8-28480
Fuel Injection Pump and Drive Gear .....	3412	8-28490
Fuel Injectors.....	3413	8-28500
<b>4 ELECTRICAL</b>		
Section Index - Electrical .....		8-74940
Removal and Installation of Electrical Components.....	4001	8-74950
Specifications, Schematics, Troubleshooting, and Sealed Connector Repair .....	4002	8-74960
Batteries .....	4003	8-74970
Starter .....	4004	8-74980
Alternator .....	4005	8-74990
<b>5 TRACK</b>		
Section Index - Track .....		8-10010
Removal and Installation of Track Components .....	5001	8-10020
Troubleshooting .....	5002	8-10030
Track Chain and Shoes .....	5003	8-10040
Track Rollers, Carrier Roller, Idler, and Sprocket.....	5004	8-10050
<b>6 POWER TRAIN</b>		
Section Index - Power Train.....		8-10060
Removal and Installation of Power Train Components.....	6001	8-10070
Drive Motor.....	6002	8-10100
Final Drive Transmission.....	6003	8-10110

**7 BRAKES**

Section Index - Brakes .....		8-10120
Removal and Installation of Brake Components .....	7001	8-10130
Drive Brake .....	7002	8-10140
Swing Brake .....	7003	8-11110

**8 HYDRAULICS**

Section Index - Hydraulics .....		8-10150
Removal and Installation of Hydraulic Components .....	8001	8-10160
Specifications, Schematics, Troubleshooting, Pressure Checks and Adjustments .....	8002	8-10170
Hydraulic Pump .....	8003	8-10180
Control Valves .....	8004	8-10190
Pilot Control System .....	8005	8-10200
Swing Motor and Swing Relief Valve .....	8006	8-10210
Hydraulic Swivel .....	8007	8-10220
Leveler .....	8008	8-10230
Cylinders .....	8009	8-10250

**9 MOUNTED EQUIPMENT**

Section Index - Mounted Equipment .....		8-10260
Pedals and Levers .....	9001	8-10090
Swing Mechanism Troubleshooting .....	9002	8-10270
Swing Gearbox .....	9003	8-10280
Boom and Arm .....	9004	8-10290
Tree Shear .....	9005	8-10300
Turntable Bearing .....	9006	8-10330

# SECTION INDEX - GENERAL

Section Title	Section Number
Standard Torque Specifications.....	1001
Fluids and Lubricants .....	1002
Detailed Engine Specifications .....	1426

**<https://www.ebooklibonline.com>**

Hello dear friend!

Thank you very much for reading.

Enter the link into your browser.

The full manual is available for immediate download.

**<https://www.ebooklibonline.com>**

# 1001

## STANDARD TORQUE SPECIFICATIONS

### TABLE OF CONTENTS

<b>Torque Specifications - Decimal Hardware</b> .....	1001-2	<b>Torque Specifications - Steel Hydraulic Fittings</b> .....	1001-4
<b>Torque Specifications - Metric Hardware</b> ...	1001-3	<b>Torque Specifications - O-ring Face Seal Fittings</b> .....	1001-5

## TORQUE SPECIFICATIONS - DECIMAL HARDWARE

Use the torques in this chart when special torques are not given. These torques apply to fasteners with both UNC and UNF threads as received from suppliers, dry, or when lubricated with engine oil. Not applicable if special graphites, molydisulfide greases, or other extreme pressure lubricants are used.

<b>Grade 5 Bolts, Nuts, and Studs</b>		
		
Size	Pound-Feet	Newton metres
<b>1/4 in</b>	9-11	12-15
<b>5/16 in</b>	17-21	23-28
<b>3/8 in</b>	35-42	48-57
<b>7/16 in</b>	54-64	73-87
<b>1/2 in</b>	80-96	109-130
<b>9/16 in</b>	110-132	149-179
<b>5/8 in</b>	150-180	203-244
<b>3/4 in</b>	270-324	366-439
<b>7/8 in</b>	400-480	542-651
<b>1.0 in</b>	580-696	787-944
<b>1-1/8 in</b>	800-880	1085-1193
<b>1-1/4 in</b>	1120-1240	1519-1681
<b>1-3/8 in</b>	1460-1680	1980-2278
<b>1-1/2 in</b>	1940-2200	2631-2983

<b>Grade 8 Bolts, Nuts, and Studs</b>		
		
Size	Pound-Feet	Newton metres
<b>1/4 in</b>	12-15	16-20
<b>5/16 in</b>	24-29	33-39
<b>3/8 in</b>	45-54	61-73
<b>7/16 in</b>	70-84	95-114
<b>1/2 in</b>	110-132	149-179
<b>9/16 in</b>	160-192	217-260
<b>5/8 in</b>	220-264	298-358
<b>3/4 in</b>	380-456	515-618
<b>7/8 in</b>	600-720	814-976
<b>1.0 in</b>	900-1080	1220-1465
<b>1-1/8 in</b>	1280-1440	1736-1953
<b>1-1/4 in</b>	1820-2000	2468-2712
<b>1-3/8 in</b>	2380-2720	3227-3688
<b>1-1/2 in</b>	3160-3560	4285-4827

**NOTE:** Use thick nuts with Grade 8 bolts.

## TORQUE SPECIFICATIONS - METRIC HARDWARE

Use the following torques when special torques are not given.

These values apply to fasteners with coarse threads as received from supplier, plated or unplated, or when lubricated with engine oil. These values do not apply if graphite or molydisulfide grease or oil is used.

<b>Grade 8.8 Bolts, Nuts, and Studs</b>		
		
Size	Pound-Feet	Newton metres
<b>M4</b>	2-3	3-4
<b>M5</b>	5-6	6.5-8
<b>M6</b>	8-9	10.5-12
<b>M8</b>	19-23	26-31
<b>M10</b>	38-45	52-61
<b>M12</b>	66-79	90-107
<b>M14</b>	106-127	144-172
<b>M16</b>	160-200	217-271
<b>M20</b>	320-380	434-515
<b>M24</b>	500-600	675-815
<b>M30</b>	920-1100	1250-1500
<b>M36</b>	1600-1950	2175-2600

<b>Grade 10.9 Bolts, Nuts, and Studs</b>		
		
Size	Pound-Feet	Newton metres
<b>M4</b>	3-4	4-5
<b>M5</b>	7-8	9.5-11
<b>M6</b>	11-13	15-17.5
<b>M8</b>	27-32	37-43
<b>M10</b>	54-64	73-87
<b>M12</b>	93-112	125-15
<b>M14</b>	149-179	200-245
<b>M16</b>	230-280	310-380
<b>M20</b>	450-540	610-730
<b>M24</b>	780-940	1050-1275
<b>M30</b>	1470-1770	2000-2400
<b>M36</b>	2580-3090	3500-4200

### Grade 12.9 Bolts, Nuts, and Studs



Usually the torque values specified for grade 10.9 fasteners can be used satisfactorily on grade 12.9 fasteners.

## TORQUE SPECIFICATIONS - STEEL HYDRAULIC FITTINGS

Tube OD Hose ID	Thread Size	Pound- Feet	Newton metres
<b>37 Degree Flare Fittings</b>			
<b>1/4 in</b> 6.4 mm	7/16-20	6-12	8-16
<b>5/16 in</b> 7.9 mm	1/2-20	8-16	11-21
<b>3/8 in</b> 9.5 mm	9/16-18	10-25	14-33
<b>1/2 in</b> 12.7 mm	3/4-16	15-42	20-56
<b>5/8 in</b> 15.9 mm	7/8-14	25-58	34-78
<b>3/4 in</b> 19.0 mm	1-1/16-12	40-80	54-108
<b>7/8 in</b> 22.2 mm	1-3/16-12	60-100	81-135
<b>1.0 in</b> 25.4 mm	1-5/16-12	75-117	102-158
<b>1-1/4 in</b> 31.8 mm	1-5/8-12	125-165	169-223
<b>1-1/2 in</b> 38.1 mm	1-7/8-12	210-250	285-338

Tube OD Hose ID	Thread Size	Pound- Feet	Newton metres
<b>Straight Threads with O-ring</b>			
<b>1/4 in</b> 6.4 mm	7/16-20	12-19	16-25
<b>5/16 in</b> 7.9 mm	1/2-20	16-25	22-23
<b>3/8 in</b> 9.5 mm	9/16-18	25-40	34-54
<b>1/2 in</b> 12.7 mm	3/4-16	42-67	57-90
<b>5/8 in</b> 15.9 mm	7/8-14	58-92	79-124
<b>3/4 in</b> 19.0 mm	1-1/16-12	80-128	108-174
<b>7/8 in</b> 22.2 mm	1-3/16-12	100-160	136-216
<b>1.0 in</b> 25.4 mm	1-5/16-12	117-187	159-253
<b>1-1/4 in</b> 31.8 mm	1-5/8-12	165-264	224-357
<b>1-1/2 in</b> 38.1 mm	1-7/8-12	250-400	339-542

<b>Split Flange Mounting Bolts</b>		
Size	Pound- Feet	Newton metres
5/16-18	15-20	20-27
3/8-16	20-25	26-33
7/16-14	35-45	47-61
1/2-13	55-65	74-88
5/8-11	140-150	190-203

## TORQUE SPECIFICATIONS - O-RING FACE SEAL FITTING

Nom. SAE Dash Size	Tube OD	Thread Size	Pound-Feet	Newton Metres	Thread Size	Pound-Feet	Newton Metres
<b>O-ring Face Seal End</b>					<b>O-ring Boss End Fitting or Locknut</b>		
-4	<b>1/4 in</b> 6.4 mm	9/16-18	10-12	14-16	7/16-20	17-20	23-27
-6	<b>3/8 in</b> 9.5 mm	11/16-16	18-20	24-27	9/16-18	25-30	33-40
-8	<b>1/2 in</b> 12.7 mm	13/16-16	32-40	43-54	3/4-16	45-50	61-68
-10	<b>5/8 in</b> 15.9 mm	1-14	46-56	60-75	7/8-14	60-65	81-88
-12	<b>3/4 in</b> 19.0 mm	1-3/16-12	65-80	90-110	1-1/16-12	85-90	115-122
-14	<b>7/8 in</b> 22.2 mm	1-3/16-12	65-80	90-110	1-3/16-12	95-100	129-136
-16	<b>1.0 in</b> 25.4 mm	1-7/16-12	92-105	125-140	1-5/16-12	115-125	156-169
-20	<b>1-1/4 in</b> 31.8 mm	1-11/16-12	125-140	170-190	1-5/8-12	150-160	203-217
-24	<b>1-1/2 in</b> 38.1 mm	2-12	150-180	200-254	1-7/8-12	190-200	258-271

# 2001

## ENGINE REMOVAL AND INSTALLATION AND RADIATOR REMOVAL AND INSTALLATION

### TABLE OF CONTENTS

Specifications .....	2001-2	Installation.....	2001-11
Special Tools.....	2001-2	Radiator .....	2001-20
Engine .....	2001-3	Removal.....	2001-20
Removal.....	2001-3	Installation.....	2001-25

## SPECIFICATIONS

### Torque Specifications

Cap screws that fasten the front engine mount to the engine..... 76 to 90 pound-feet  
(103 to 122 Nm)

Cap screws that fasten the fan to the engine .....456 to 564 pound-inches  
(52 to 64 Nm)

## SPECIAL TOOLS

Special tools can be ordered from Service Tools, P.O. Box 314, Owatonna, Minnesota 55060 in the U.S.A. and from Jobborn Manufacturing Company, 97 Frid Street, Hamilton Ontario L8P 4M3 in Canada.

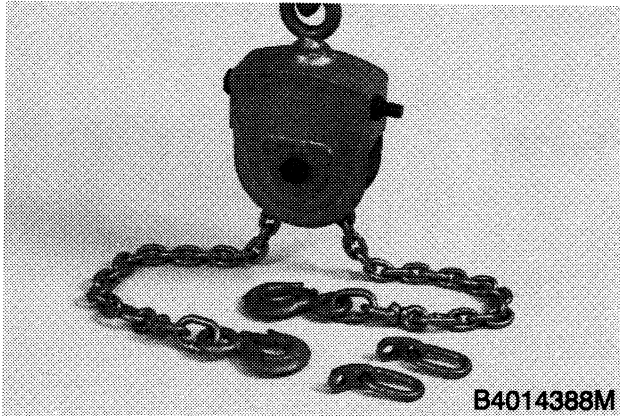

**B4014388M**

*CAS-10119 Adjustable Chain Lifting Sling, Includes CAS-10700 Lifting Eyes*

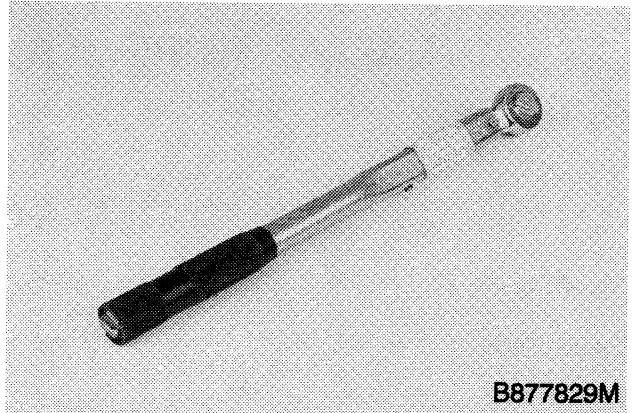

**B877829M**

*CAS-10034 100 to 750 Pound-Inch Torque Wrench*

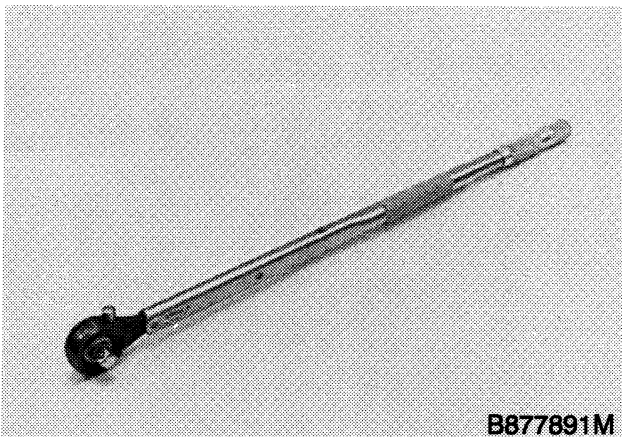

**B877891M**

*CAS-10036 50 to 250 Pound-Foot Torque Wrench*

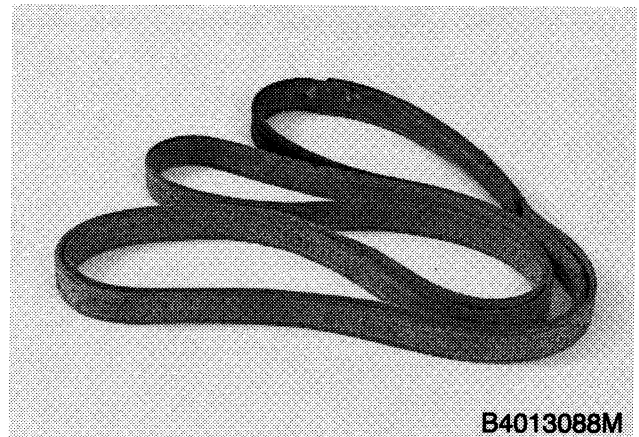

**B4013088M**

*CAS-10821 Lifting Sling*

## ENGINE

### Removal

Park the machine on a level surface. Lower the attachment to the floor. Put the drive brake switch in the ON position. Stop the engine and apply the swing brake.

#### STEP 1

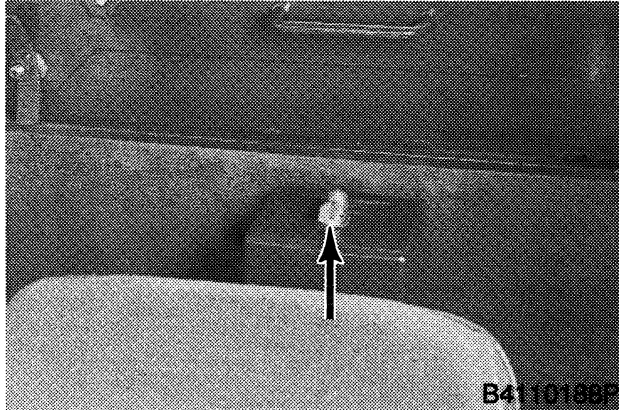

Put the master disconnect switch in the OFF position.

#### STEP 2

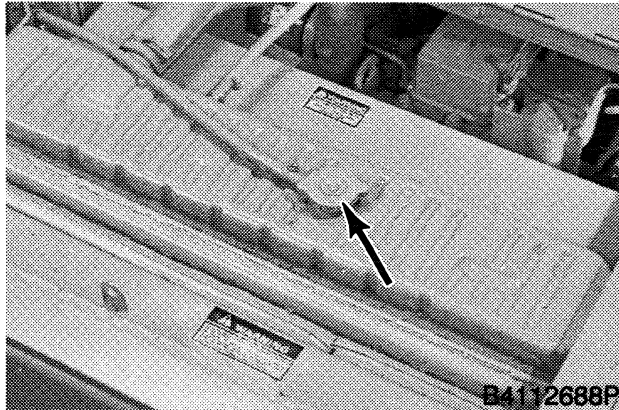

Loosen the cap on the radiator.

#### STEP 3

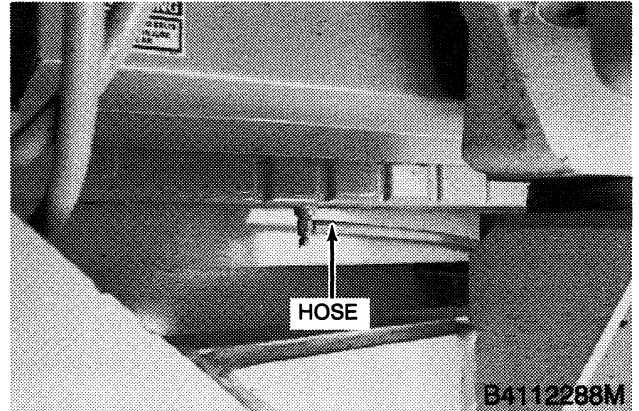
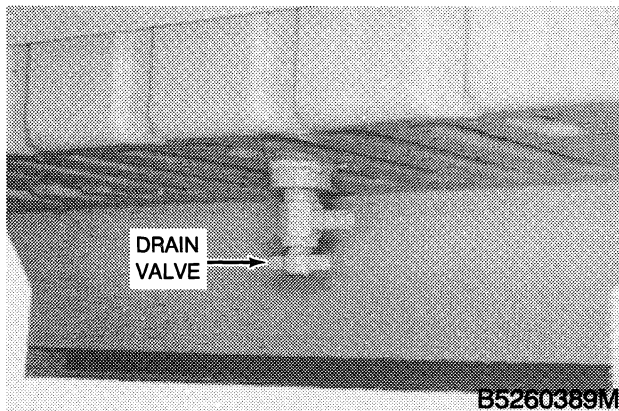

Connect a hose to the drain valve on the radiator. Open the drain valve and drain the coolant from the radiator.

#### STEP 4



Remove the cover from the muffler.

#### STEP 5

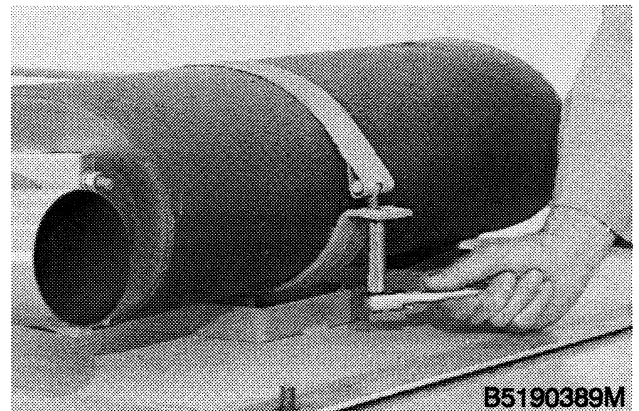

Remove the muffler from the machine.

**STEP 6**

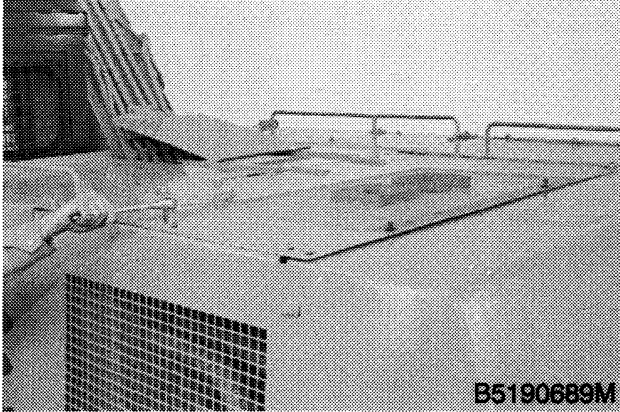

Loosen and remove the hardware that fastens the top rear cover to the machine.

**STEP 7**

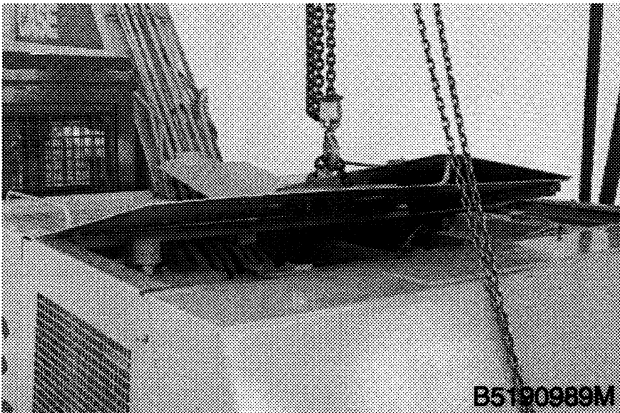

Remove the top rear cover from the machine.

**STEP 8**

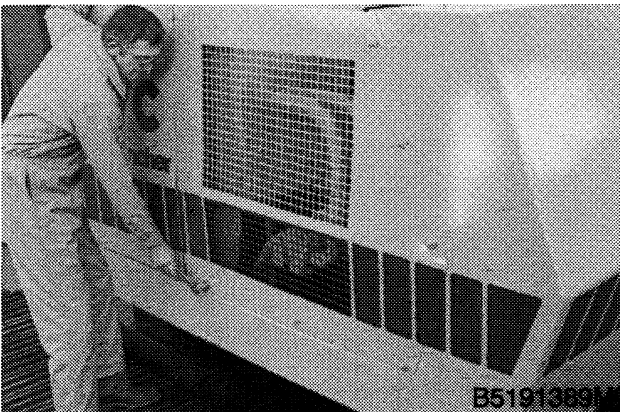

Remove the left rear cover from the machine.

**STEP 9**

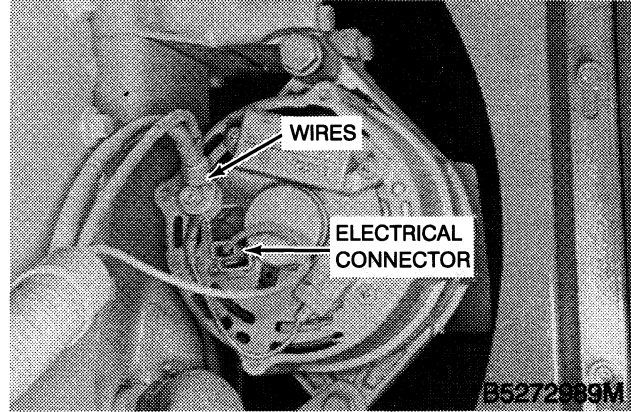

Disconnect the wires from the alternator. Disconnect the electrical connector from the alternator.

**STEP 10**

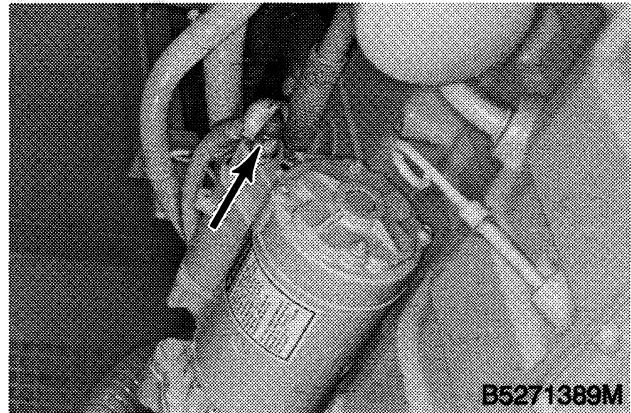

Move the rubber boot out of the way and disconnect the wire and cable from the terminal on the starter solenoid.

**STEP 11**

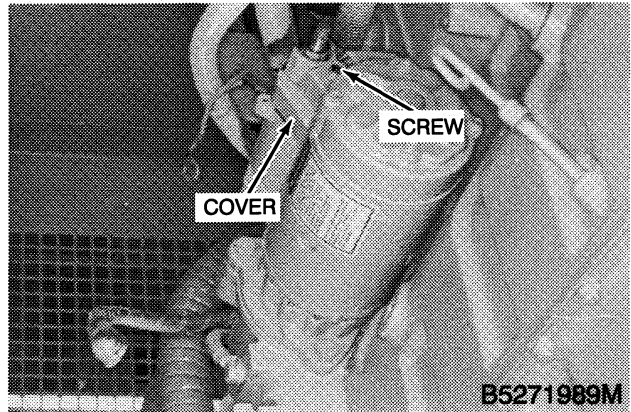

Remove the screw and the cover from the starter solenoid.

**STEP 12**



Disconnect the wire from the starter solenoid.

**STEP 13**

Move the wiring harness out of the way.

**STEP 14**

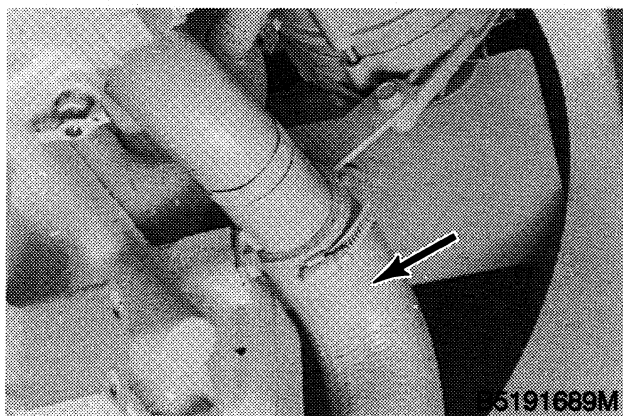

Disconnect the lower radiator hose from the engine.

**STEP 15**

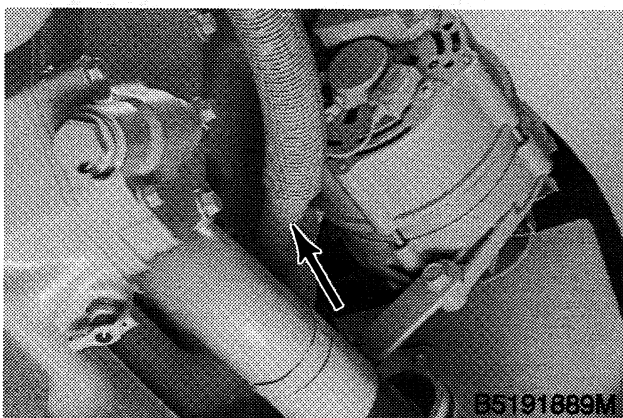

Disconnect the heater hose from the engine. Install a plug in the heater hose.

**STEP 16**

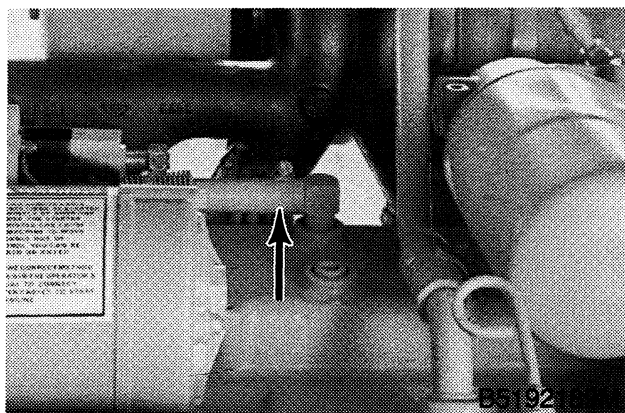

Disconnect the other heater hose from the engine. Install a plug in the heater hose. Move the heater hoses out of the way.

**STEP 17**

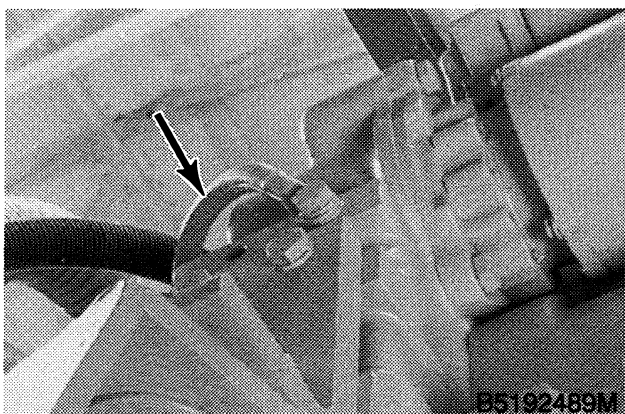

Disconnect the ground cable from the engine.

**STEP 18**

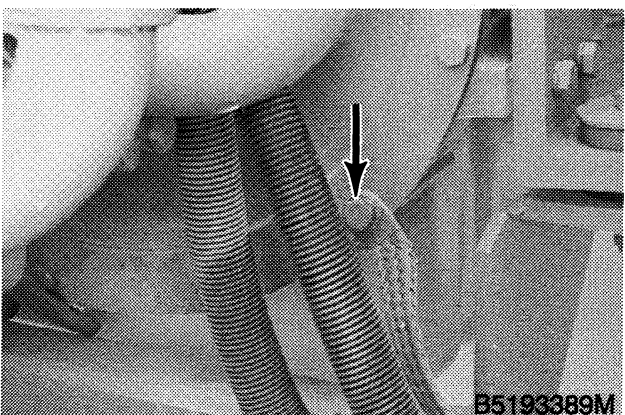

Disconnect the ground strap from the engine.

**STEP 19**

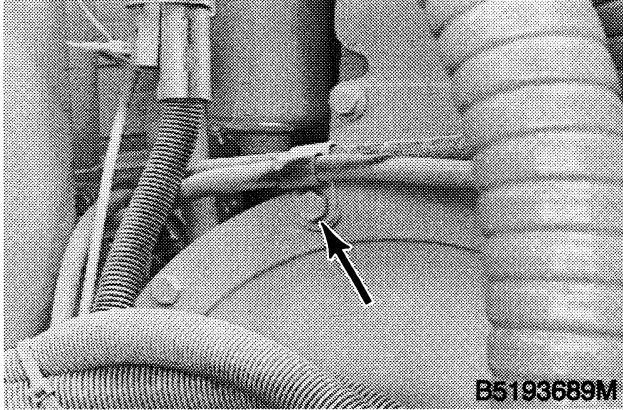

Disconnect the clamps for the wiring harness and ground cable from the engine. Move the ground cable and wiring harness out of the way.

**STEP 20**

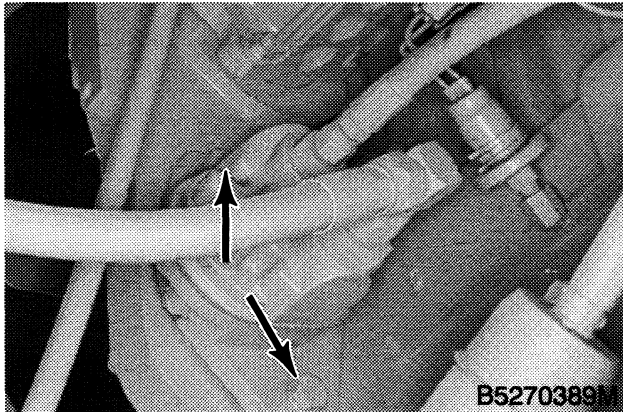

Loosen and remove the cap screws and lock washers that fasten the pilot control pump to the engine. Remove the pilot control pump, gaskets, and shim from the engine. Fasten the pilot control pump out of the way. Be careful not to damage the gear on the pilot control pump.

**NOTE:** A plug must be installed in the supply hose as soon as the hose is disconnected from the hand primer pump.

**STEP 21**

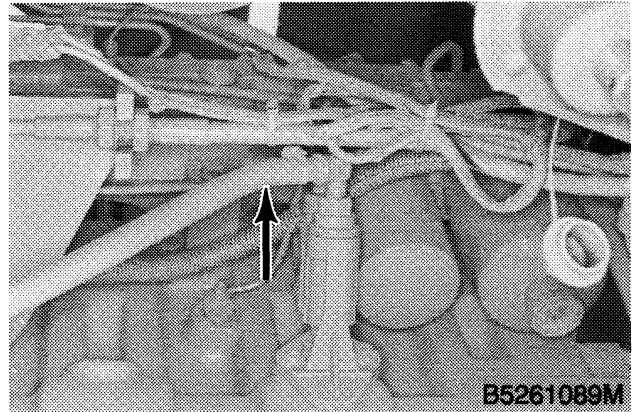

Disconnect the supply hose from the hand primer pump. Install the plug in the supply hose.

**NOTE:** A plug must be installed in the return hose as soon as the return hose is disconnected from the fuel injection pump in the next step.

**STEP 22**

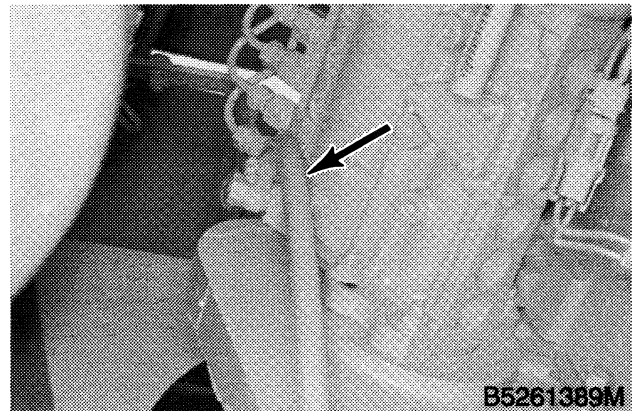

Disconnect the return hose from the fuel injection pump. Install a plug in the return hose.

**STEP 23**

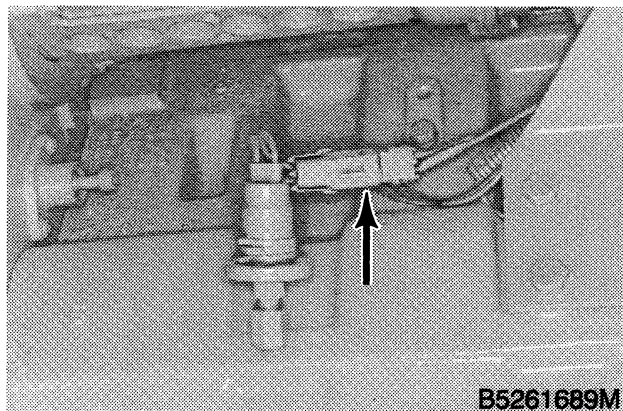

Disconnect the electrical connector for the engine oil pressure switch.

**STEP 26**

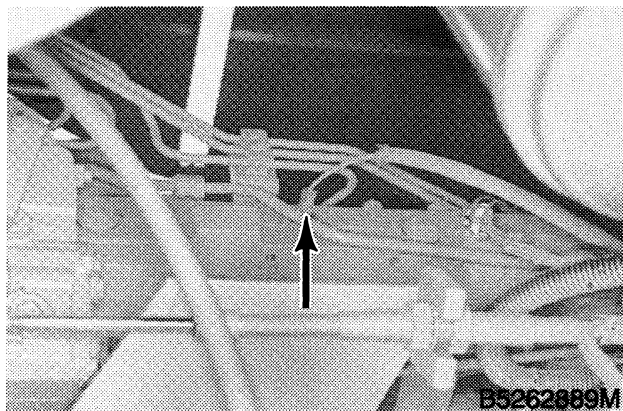

Disconnect the ether injection tube from the fitting on the intake manifold.

**STEP 24**

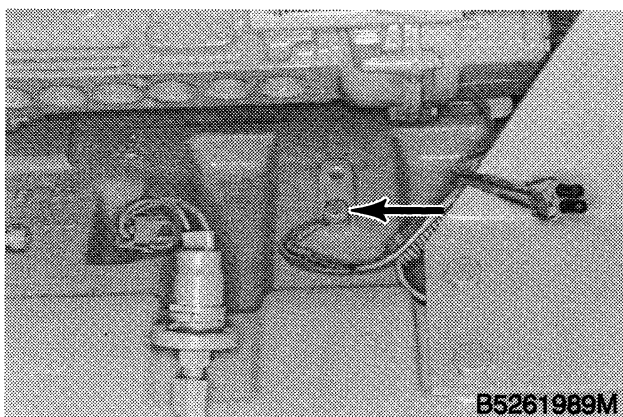

Disconnect the ground wire from the engine.

**STEP 27**

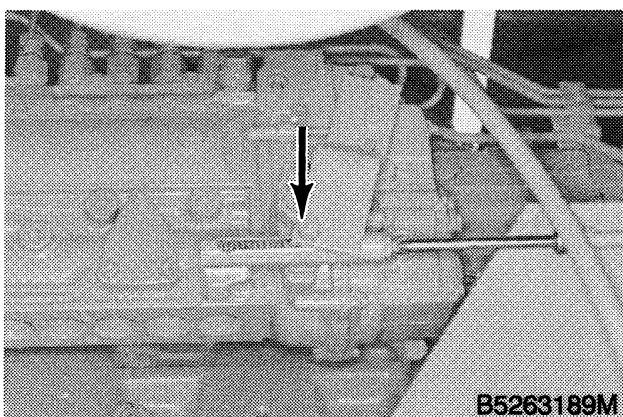

Disconnect the throttle linkage from the arm on the fuel injection pump.

**STEP 25**

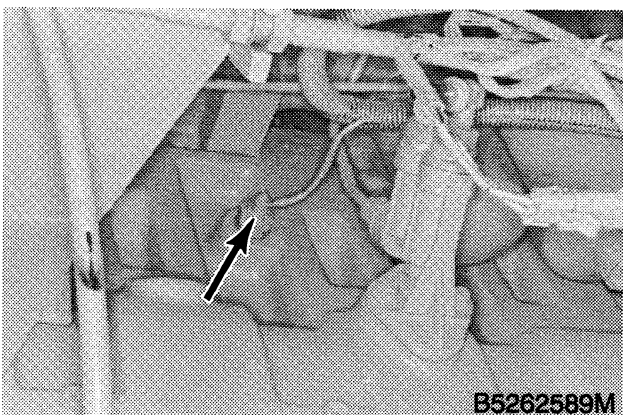

Disconnect the wire from the engine temperature sender.

**STEP 28**

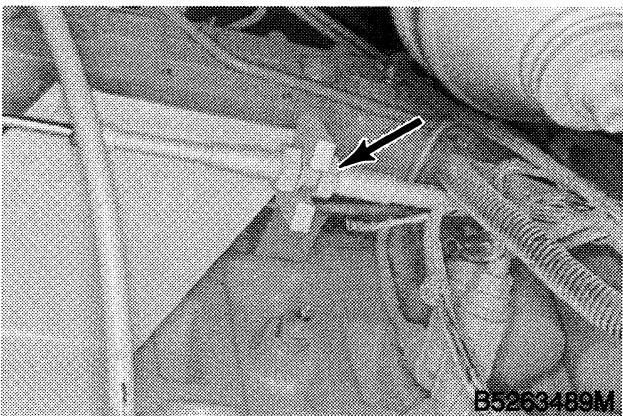

Loosen the jam nut that holds the throttle linkage to the bracket. Move the throttle linkage out of the way.

**STEP 29**

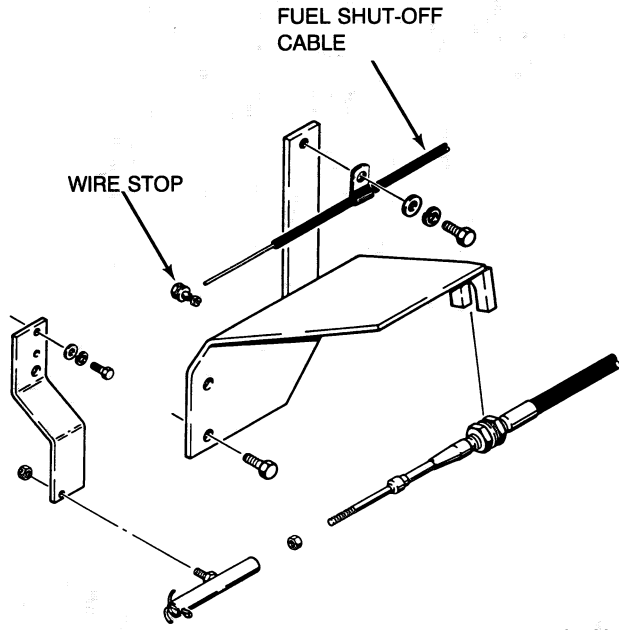

B0333A89M

Fuel Shut-Off Cable Installation

Disconnect the fuel shut-off cable from the lever on the fuel injection pump. Move the fuel shut-off cable out of the way.

**STEP 30**

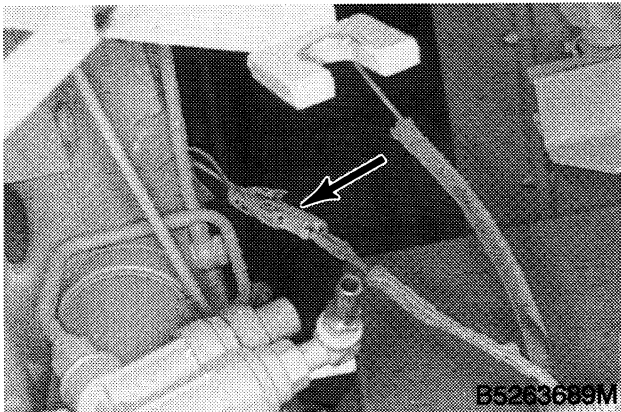

Disconnect the electrical connector for the engine manifold temperature switch. Move the wiring harness out of the way.

**STEP 31**

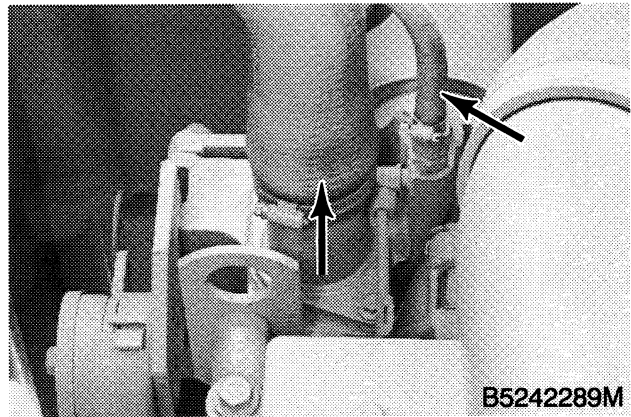

Disconnect the upper radiator hose and the hose to the coolant filter from the engine. Close the openings in the engine.

**STEP 32**

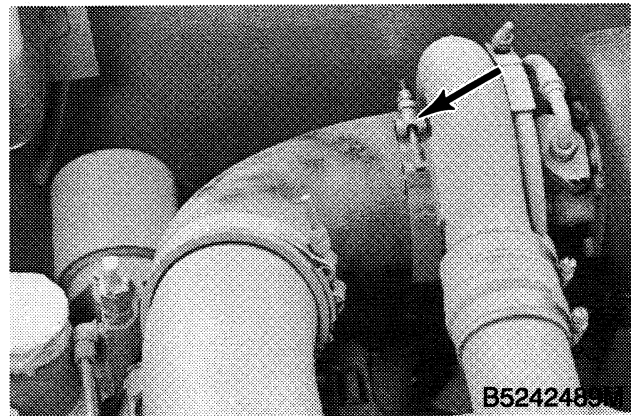

Disconnect the air cleaner hose from the turbocharger.

**STEP 33**

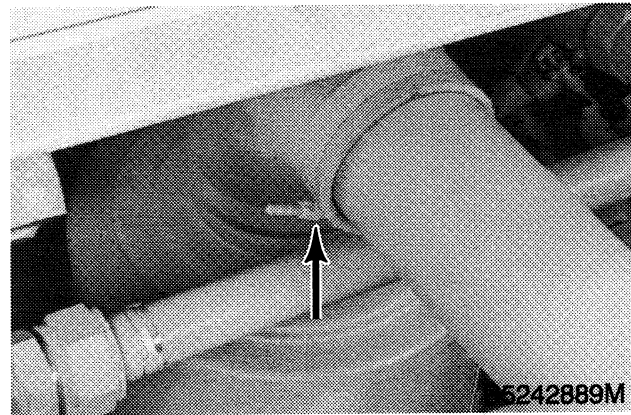

Disconnect the tube for the air cleaner from the rubber elbow at the top of the air cleaner. Remove the air cleaner tube from the machine. Cover the opening in the turbocharger.

**STEP 34**

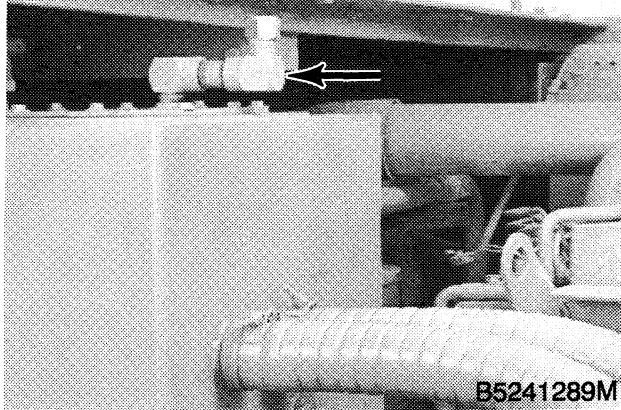

Remove the breather from the hydraulic reservoir. Install a plug in the fitting for the breather.

**STEP 37**

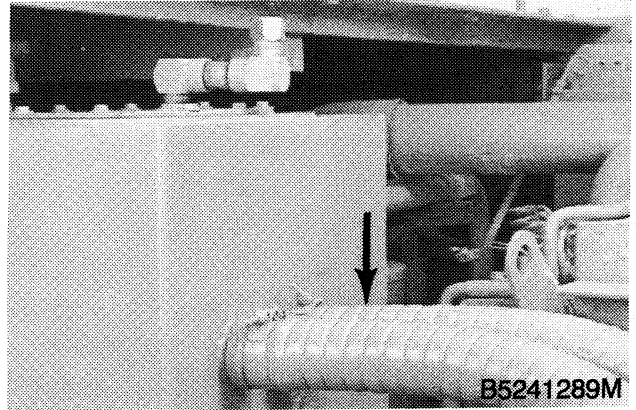

Disconnect the hoses from the hydraulic reservoir. Install plugs in the hoses and plugs in the openings for the hydraulic reservoir.

**STEP 35**

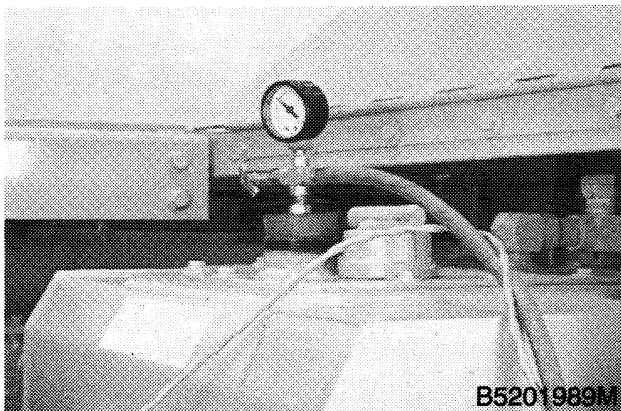

Open the access cover behind the operators compartment. Connect a vacuum pump to the hydraulic reservoir. Close the access cover behind the operators compartment.

**STEP 38**

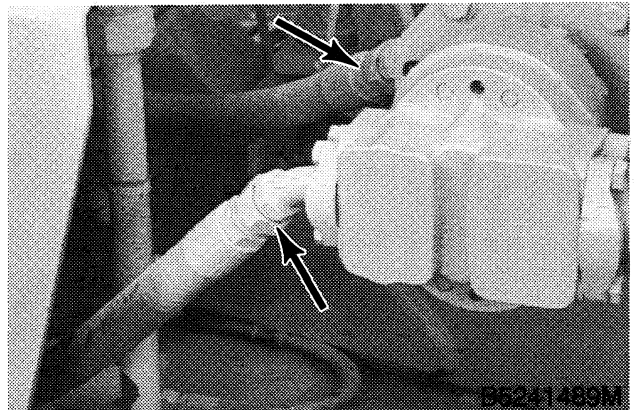

Disconnect the hoses from the fittings on the hydraulic pump. Install caps on the fittings and plugs in the hoses.

**STEP 36**

Start the vacuum pump.

**STEP 39**

Stop the vacuum pump.



**Suggest:**

**If the above button click is invalid.**

**Please download this document**

**first, and then click the above link**

**to download the complete manual.**

**Thank you so much for reading**

**STEP 40**

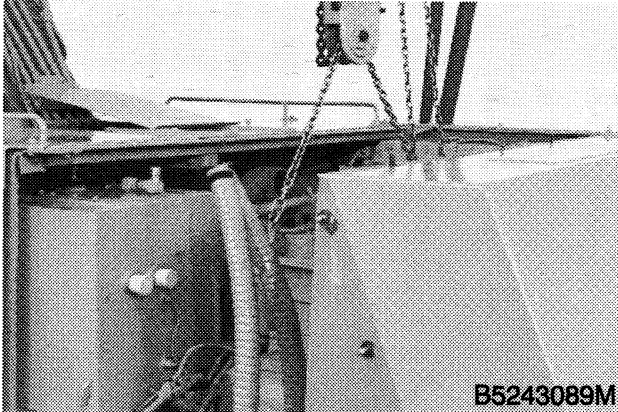

Connect the CAS-10119 adjustable chain lifting sling to the lifting eyes on the engine. Connect the chain hoist to the adjustable chain lifting sling.

**STEP 41**

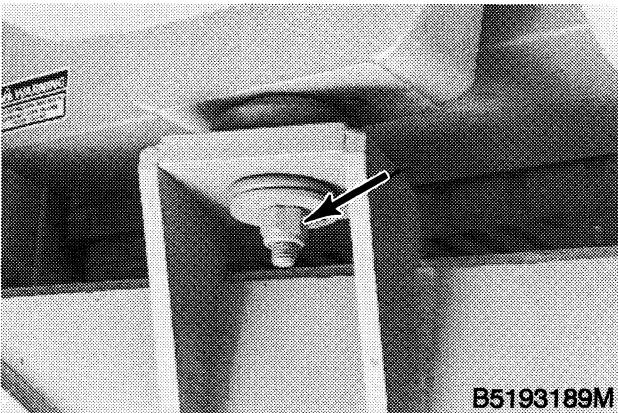

Loosen the self-locking nut on the bolt that fastens the engine to the mounting bracket on the right side of the machine.

**STEP 42**

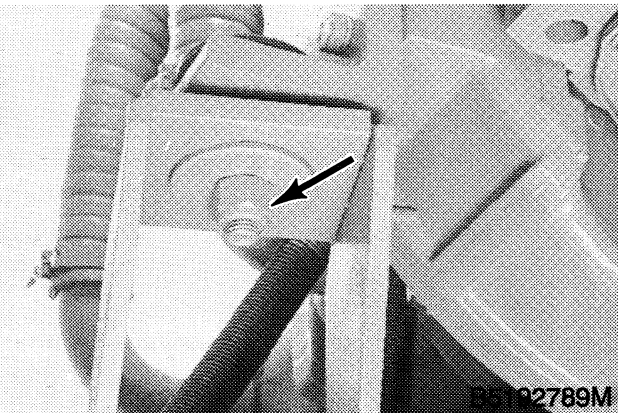

Loosen and remove the bolts, hardened washers, and self-locking nuts that fasten the engine to the mounting brackets on the left side of the machine.

**STEP 43**

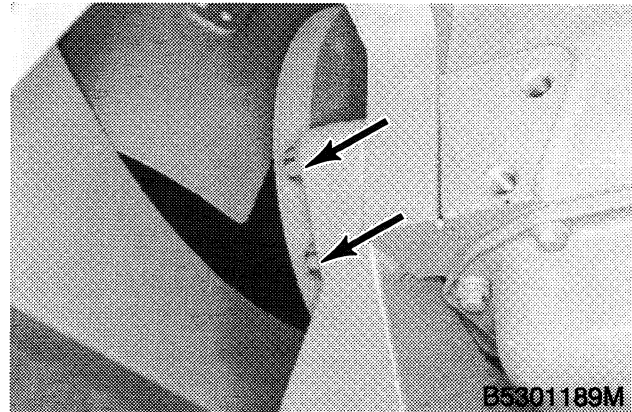

Lift the engine until the weight of the engine is removed from the mounting bracket on the right side of the machine. Loosen and remove the cap screws that fasten the engine support to the engine.

**STEP 44**

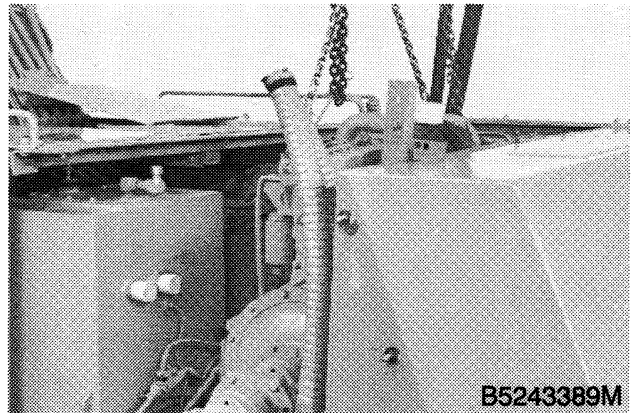

Carefully move the engine toward the left side of the machine until the fan clears the radiator shroud. Lift the engine until the oil pan on the engine will be clear of the machine frame.

**STEP 45**

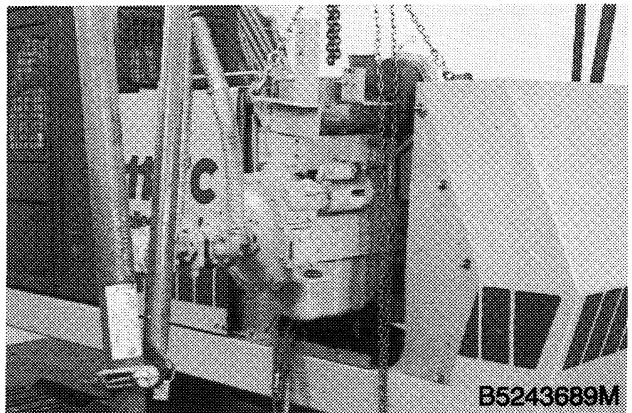

Carefully remove the engine from the machine.

**<https://www.ebooklibonline.com>**

Hello dear friend!

Thank you very much for reading.

Enter the link into your browser.

The full manual is available for immediate download.

**<https://www.ebooklibonline.com>**