

Section: ENGINE  
CRANKCASE

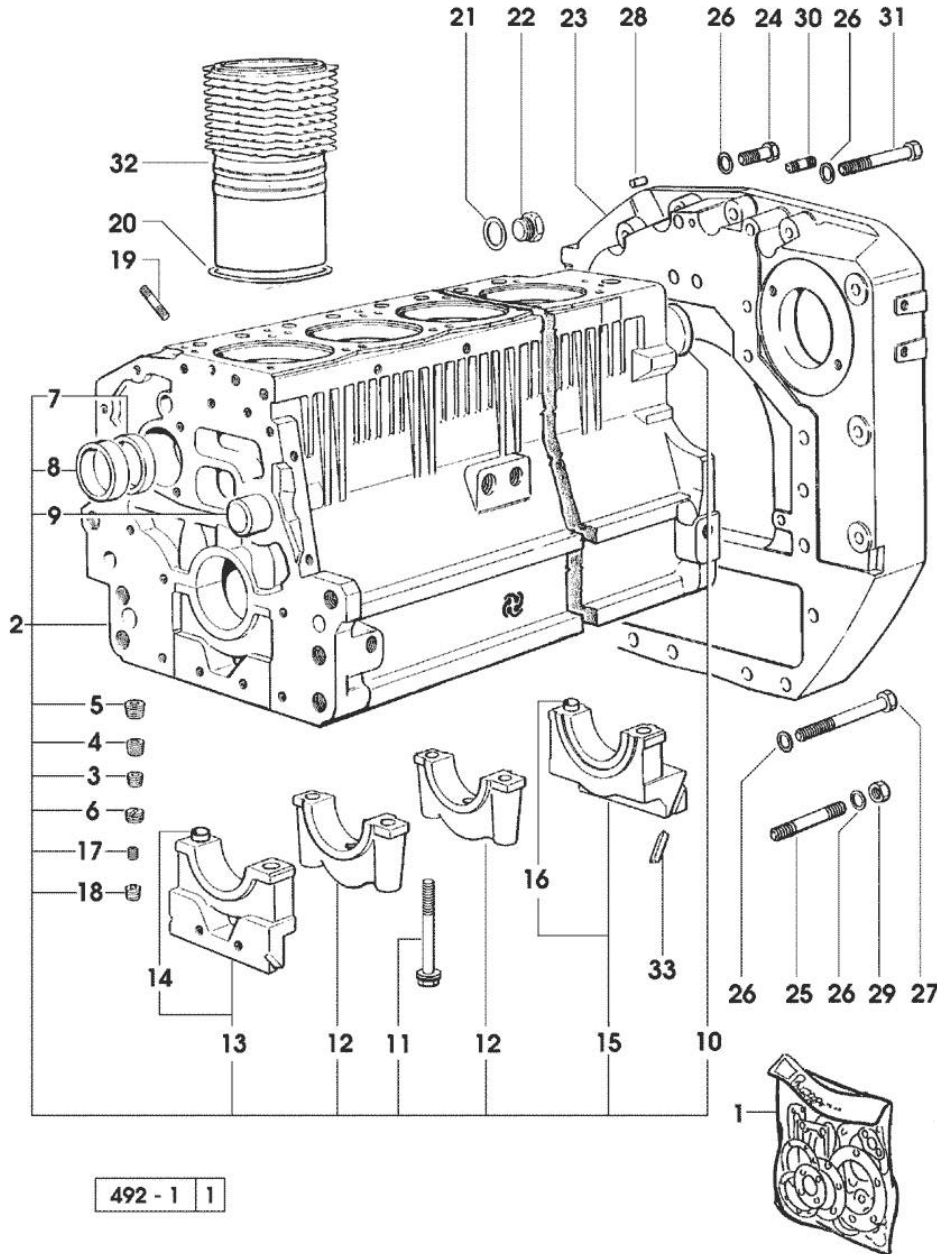

492 - 1 1

Fig.	P/n	QTY	Name
<b>Notes:</b>			
2000 <- X TITAN 160 [TITAN 145]			
1	0.336.0050.6	1	gasket set - FOR ENGINE MOUNTING
2	0.007.0779.6/20	1	crankcase * 2234 <= X TITAN 160 - 007.0876.0/10
3	2.3130.002.1	2	plug 1/4" gas
4	2.3130.003.1	7	plug 3/8" gas
5	2.3131.006.0	1	plug m 22 x 1.5
6	2.1324.011.0	1	plug
7	0.065.1140.0	6	special bushing 59X55X20
8	0.065.1141.0	1	special bushing 59X55X30
9	0.066.1151.0	1	pin
10	2.3179.012.0	1	plug 60
11	0.065.1117.0	14	screw m 12 x 100
12	0.065.1114.0/10	5	support
13	0.065.1112.7	1	support
14	2.1699.165.0	1	bush 12.3x15x16
15	0.007.0848.3/10	1	support
16	2.1699.165.0	1	bush 12.3x15x16
17	2.3199.092.0	6	plug 8 x 12
18	2.3130.001.1	15	plug 1/8" gas
19	2.0432.003.7	18	stud bolt m 8 p.1.25 / p.1 x 20
20	2.1539.130.0/10	6	special oil seal 117.07x3.53
21	2.1539.047.0	1	special oil seal 26.7x1.78
22	2.3199.405.2	1	plug m 28 p.1.5
23	0.007.0809.0/20	1	flange * 1370 <- X TITAN 145 * 1395 <- X TITAN 160 - N.4 - 2.1699.448.0
24	2.0112.513.2	11	screw m 14 p.2 x 35
25	2.0432.328.7	4	stud bolt m 14 p.2-1.5x130
26	2.1470.008.2	19	lock washer 14
27	2.0112.534.2	2	screw m 14 p.2x125
28	2.1653.911.0	2	cylindrical plug 12x25
29	2.1011.108.2	4	nut m 14 p.2
30	2.0432.255.7	2	stud bolt m 12 p.1.75-1.25x25
31	2.0312.520.1	2	screw m 14 p.2x70
32	0.007.0762.0/50	6	engine cylinder
33	0.066.1152.0/10	4	gasket

Section: ENGINE

**TIMING CASE**

Fig.	P/n	QTY	Name
------	-----	-----	------

**Notes:**

[TITAN 145]

1	0.007.1262.3/50	1	guard
2	0.007.1271.0/10	1	small column m 8 p.1.25 / L = mm 60
3	0.007.1272.0/10	2	small column m 8 p.1.25 / L = mm 50
5	2.1310.004.2	3	flat washer 8.4x17
7	2.0112.205.2	3	screw m 8 p.1.25 x 16

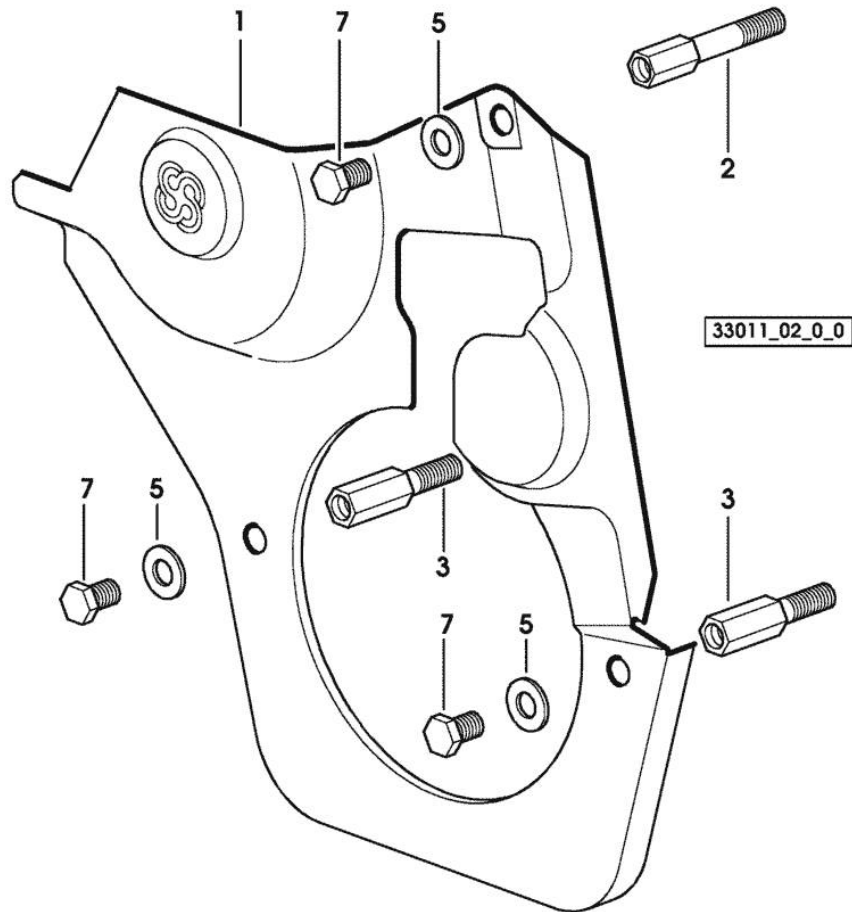

Section: ENGINE  
TIMING CASE

Fig.	P/n	QTY	Name
------	-----	-----	------

Notes:  
[TITAN 145]

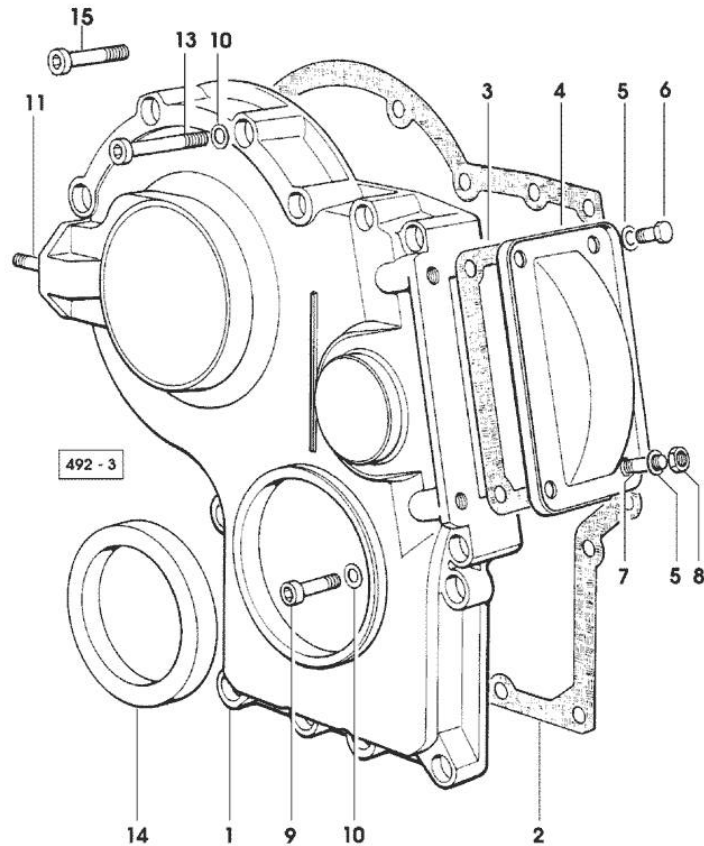

1	0.065.1132.0/60	1	guard
2	0.065.1150.0/30	1	gasket
3	0.065.1152.0	1	gasket
4	0.065.1151.0	1	cover
5	2.1470.004.2	4	lock washer 8
6	2.0112.205.2	2	screw m 8 p.1.25 x 16
7	2.0432.003.7	2	stud bolt m 8 p.1.25 / p.1 x 20
8	2.1011.405.2	2	nut m 8 p.1
9	2.0312.214.1	3	screw m 8 p.1.25 x 40
10	2.1480.014.1	15	washer 8
11	2.0432.003.7	2	stud bolt m 8 p.1.25 / p.1 x 20
13	2.0312.219.2	4	screw m 8 p.1.25x65
14	2.1529.141.0	1	special oil seal
15	2.0312.208.2	8	screw m 8 p.1.25 x 25

**<https://www.ebooklibonline.com>**

Hello dear friend!

Thank you very much for reading.

Enter the link into your browser.

The full manual is available for immediate download.

**<https://www.ebooklibonline.com>**

Section: ENGINE

**CRANKSHAFT**

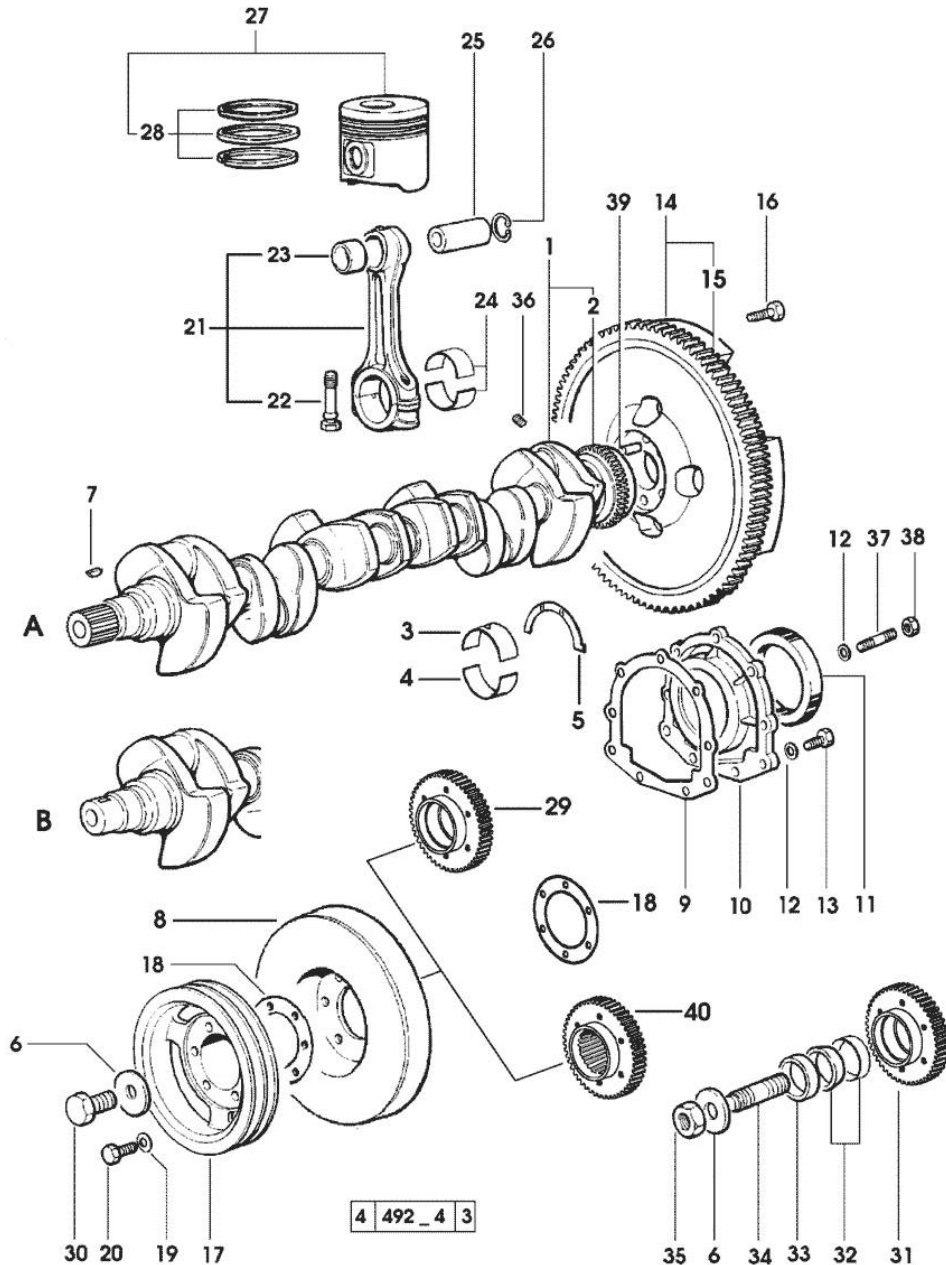

Fig.	P/n	QTY	Name
<b>Notes:</b> [TITAN 145]			
1	0.010.4320.3/20	1	crankshaft (...) <= " B " * N.1 011.2206.0/10
2	0.007.0855.0	1	gear
3	0.065.1215.0	7	main half bushing STANDARD
3	0.065.1215.7		main half bushing - mm 0.25
3	0.065.1215.8		main half bushing - mm 0.50
4	0.065.1216.0	7	main half bushing
4	0.065.1216.7		main half bushing - mm 0.25
4	0.065.1216.8		main half bushing - mm 0.50
5	0.065.1218.0	4	shim STANDARD
5	0.065.1218.7		shim + mm 0.10
5	0.065.1218.8		shim + mm 0.15
6	2.1599.524.7	1	washer 21x60x12
7	2.1720.006.0	1	key 4x6.5
8	0.007.1010.3	1	antivibration pulley
9	0.065.1254.0/20	1	gasket
10	0.007.0851.0/10	1	cover
11	2.1529.073.0	1	special oil seal 110x130x13
12	2.1474.009.2	9	spring washer 8
13	2.0112.207.2	7	screw m 8 p 1.25 x 20
14	0.007.0655.3/20	1	flywheel
15	0.065.1242.0	1	crown wheel Z = 123
16	2.0119.174.0/10	6	screw m 12 p.1.25x45
17	0.007.0962.0/20	1	pulley -> 2001 X TITAN 160 - X TITAN 190
17	0.008.2212.0/60	1	pulley 1239 <= X TITAN 160
17	0.008.2212.0/70	1	pulley => 1240 - 2000 <- X TITAN 160
18	2.1589.136.0		shoulder ring 71x110x0.5
18	2.1589.137.0		shoulder ring 71x110x1
19	2.1470.006.2	6	lock washer 10
20	2.0112.322.2	6	screw m 10 p.1.5x65
21	0.007.1395.3/20	6	engine connecting rod
22	2.0399.213.0	12	screw m 12 p.1.25x61.5
23	2.1559.255.0	6	special bushing 34.60x39.130x34.65
24	0.065.1225.0	12	con.rod half bushing STANDARD - A = 28.75 -> 29.00
24	0.065.1225.7		con.rod half bushing - mm 0.25
24	0.065.1225.8		con.rod half bushing - mm 0.50

Section: ENGINE

CRANKSHAFT

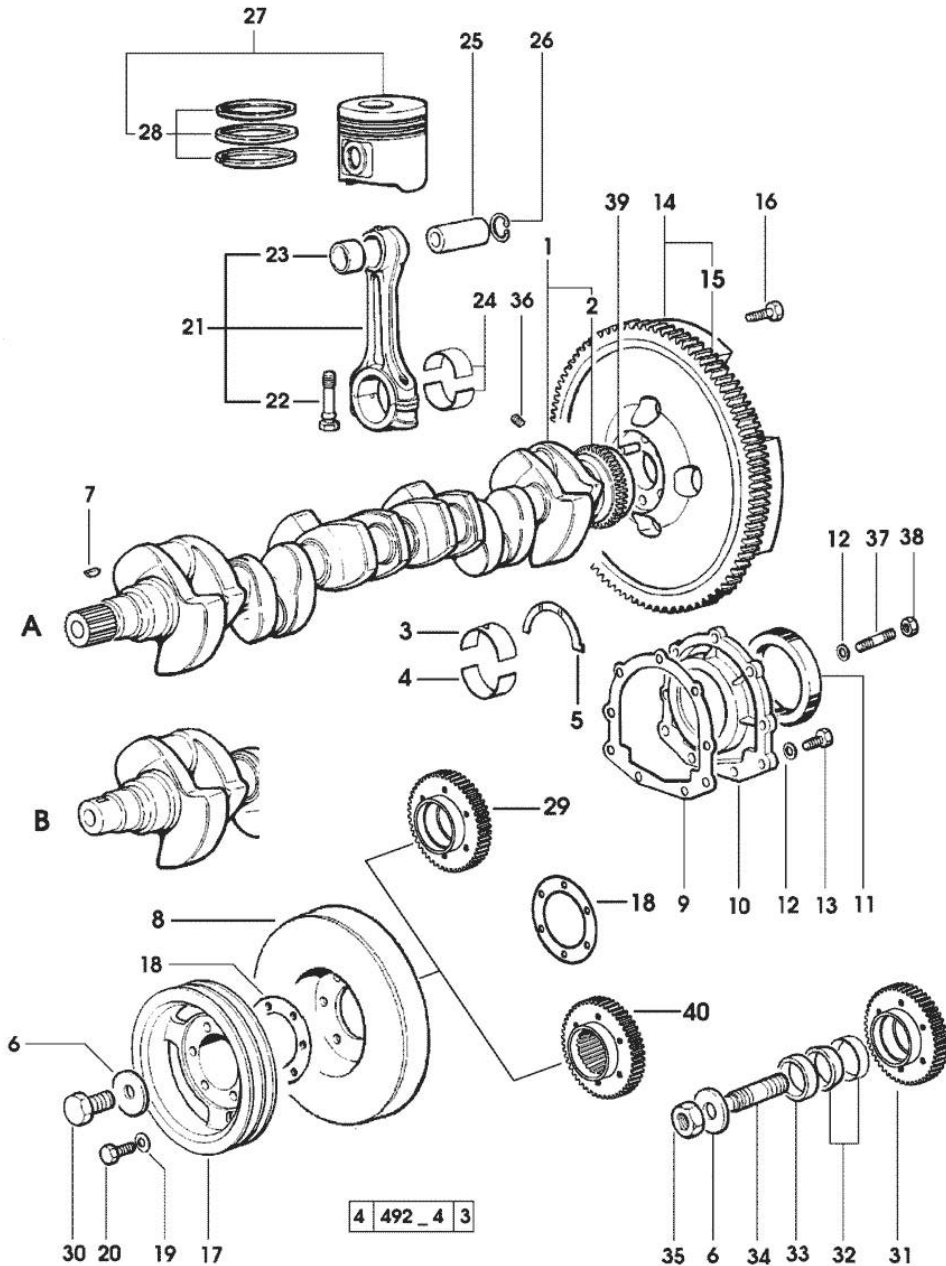

Fig.	P/n	QTY	Name
25	0.038.1236.0/10	6	piston pin Ø 18 / Ø 35 / L = mm 90
26	2.1411.014.1	12	circlip 35
27	0.340.0060.6/10	6	complete piston
27	0.383.0060.6	6	complete piston - X TITAN 160 190 - EXPORT U.S.A.
28	0.338.0052.6/10	6	piston ring set
29	0.011.2140.0/10	1	hub - X B (...) <=
30	2.0399.144.7/10	1	screw m 20 p.1.5x51
31	0.011.2141.0/10	1	hub - FOR MODELS EQUIPPED WITH FRONT P.T.O. - X B (...) <=
32	0.035.1263.0	2	ring - X B (...) <=
33	2.1579.949.0	1	ring 50.2x56.8x8 - X B (...) <=
34	2.0439.195.7	1	stud bolt m 20 p.1.5x80 - X B (...) <=
35	2.1019.094.7	1	nut m 20 p.1.5 - X B (...) <=
36	2.3130.001.1	6	plug 1/8" gas
37	2.0432.003.7	2	stud bolt m 8 p.1.25 / p.1 x 20
38	2.1011.105.2	2	nut m 8 p.1.25
39	2.1652.915.0	1	cylindrical plug 12x35
40	0.011.2206.0/10	1	hub - X A => (...)

Section: ENGINE

**CAMSHAFT**

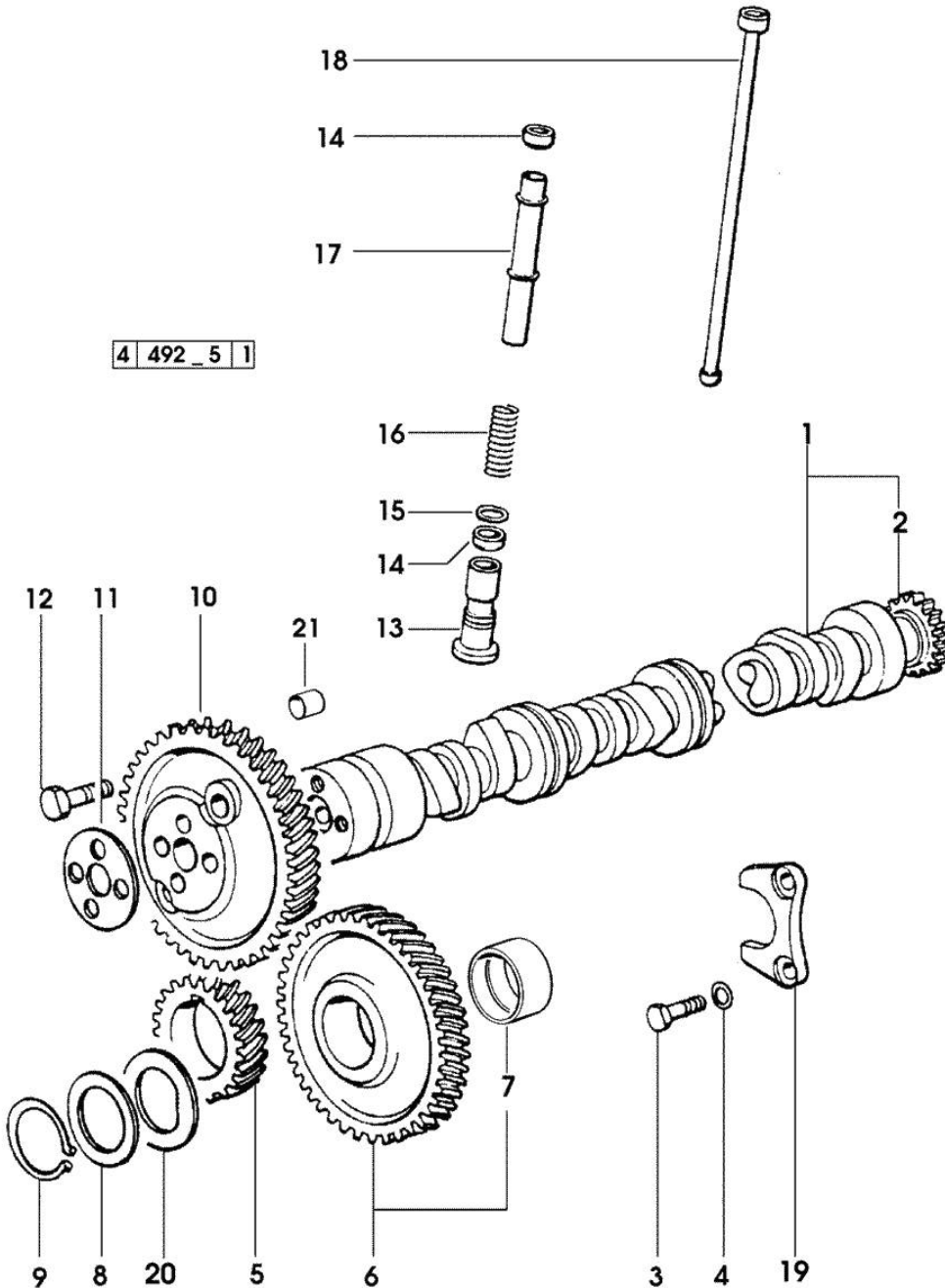

Fig.	P/n	QTY	Name
------	-----	-----	------

Notes:  
[TITAN 145]

1	0.010.4968.3/10	1	camshaft - X 190HP - EXPORT U.S.A.
1	0.075.1310.3/30	1	camshaft
2	0.065.1324.0/10	1	gear Z = 32
3	2.0312.206.2	2	screw m 8 p 1.25 x 20
4	2.1480.014.1	2	washer 8
5	0.007.1188.0/20	1	gear Z = 29
6	0.007.1177.3/10	1	gear z = 57 - WITH RED IDENTIFICATION STAMP
6	0.007.1178.3/10		gear z = 57 - WITH YELLOW IDENTIFICATION STAMP
6	0.007.1179.3/10		gear z = 57 - WITH GREEN IDENTIFICATION STAMP
7	2.1559.185.0/10	2	bushing
8	0.065.1352.0	1	shim
9	2.1410.016.1	1	circlip 40
10	0.065.1354.0/20	1	gear z=58
11	0.065.1350.0	1	small disc
12	2.0132.207.2	4	screw m 10 p.1 x 25
13	0.065.1330.0	12	tappets
14	2.1569.114.0/10	24	gasket 14x18.5x8
15	2.1599.437.0	12	shoulder ring
16	2.4019.300.1/10	12	spring 18.5x52x2
17	0.065.1332.0	12	sleeve
18	0.065.1331.2	12	rod
19	0.065.1353.0	1	small plate
20	0.065.1351.0	2	shoulder ring
21	2.1559.398.0	1	bushing 10.5x13x12

Section: ENGINE  
CYLINDER HEAD

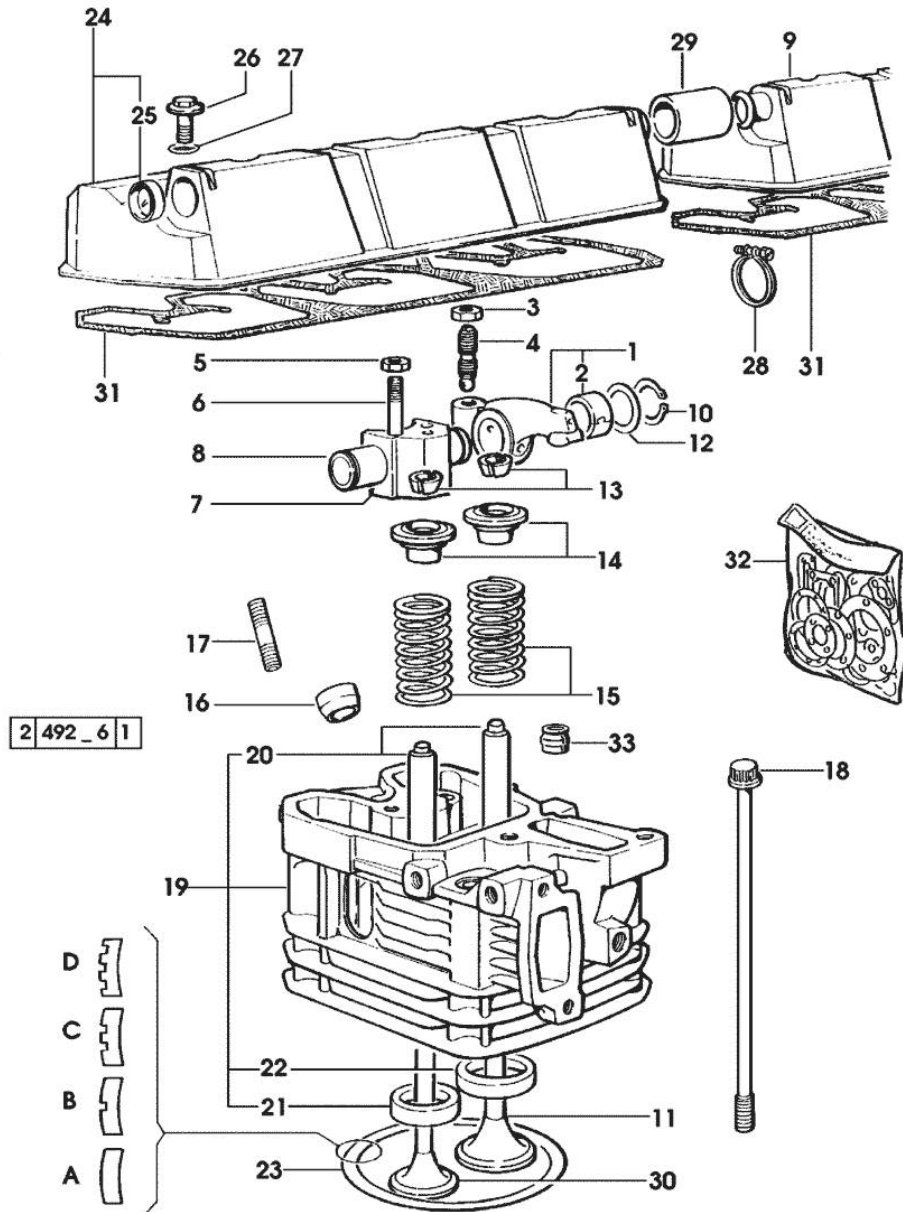

Fig.	P/n	QTY	Name
------	-----	-----	------

Notes:

2000 <- X TITAN 160 [TITAN 145]

1	0.066.1432.0	6	rocker arm
2	2.1559.021.0/40	6	bushing 15x19x22
3	2.1011.405.2	12	nut m 8 p.1
4	0.021.1434.0	12	screw
5	2.1011.421.2	12	nut m 10 p.1.25
6	2.0432.163.7	12	stud bolt m 10 p.1.5 / p.1.25 x 45
7	0.066.1430.0/10	6	support
8	0.066.1431.0	12	pin
9	0.078.1450.3	1	cover
10	2.1410.055.1	12	circlip 19
11	0.007.1146.0/10	6	inlet valve mm 43.63 / Ø mm 9
12	2.1599.432.0	12	shoulder ring
13	0.074.1423.0	24	conical valve cotter
14	0.066.1425.0	12	cup
15	2.4019.287.0	12	spring
16	0.007.1122.0/10	6	bush L = mm 6.4
17	2.0432.161.7	6	stud bolt m 10 p.1.5 / p.1.25 x 40
18	0.065.1443.0/20	24	screw
19	0.007.1359.3/50	6	engine head
20	0.007.1779.0/10	12	valve guide
21	0.066.1427.0	6	valve seat
22	0.078.1426.0	6	valve seat
23	0.085.1450.0	1	head gasket mm 0.5 -A-
23	0.085.1451.0	2	head gasket mm 0.7 -B-
23	0.085.1452.0	1	head gasket mm 1.0 -C-
23	0.085.1453.0	2	head gasket mm 0.8 -D-
24	0.078.1440.3	1	cover
25	2.3171.008.4	1	plug 20
26	2.0399.130.2	6	screw m 8 x 30
27	2.1532.035.0	6	oil seal 14x1.78
28	2.6859.052.2	2	clamp
29	0.075.1452.0/10	1	sleeve
30	0.007.1147.0/10	6	exhaust valve mm 39.1 / Ø mm 9
31	0.009.3877.0/10	2	tappet gasket
32	0.336.0057.6		gasket set
			- FOR 1 CYLINDER VALVE GRINDING AND PISTON RINGS REPLACEMENT
33	2.1519.117.0	12	special oil seal

Section: ENGINE  
LUBRICATION

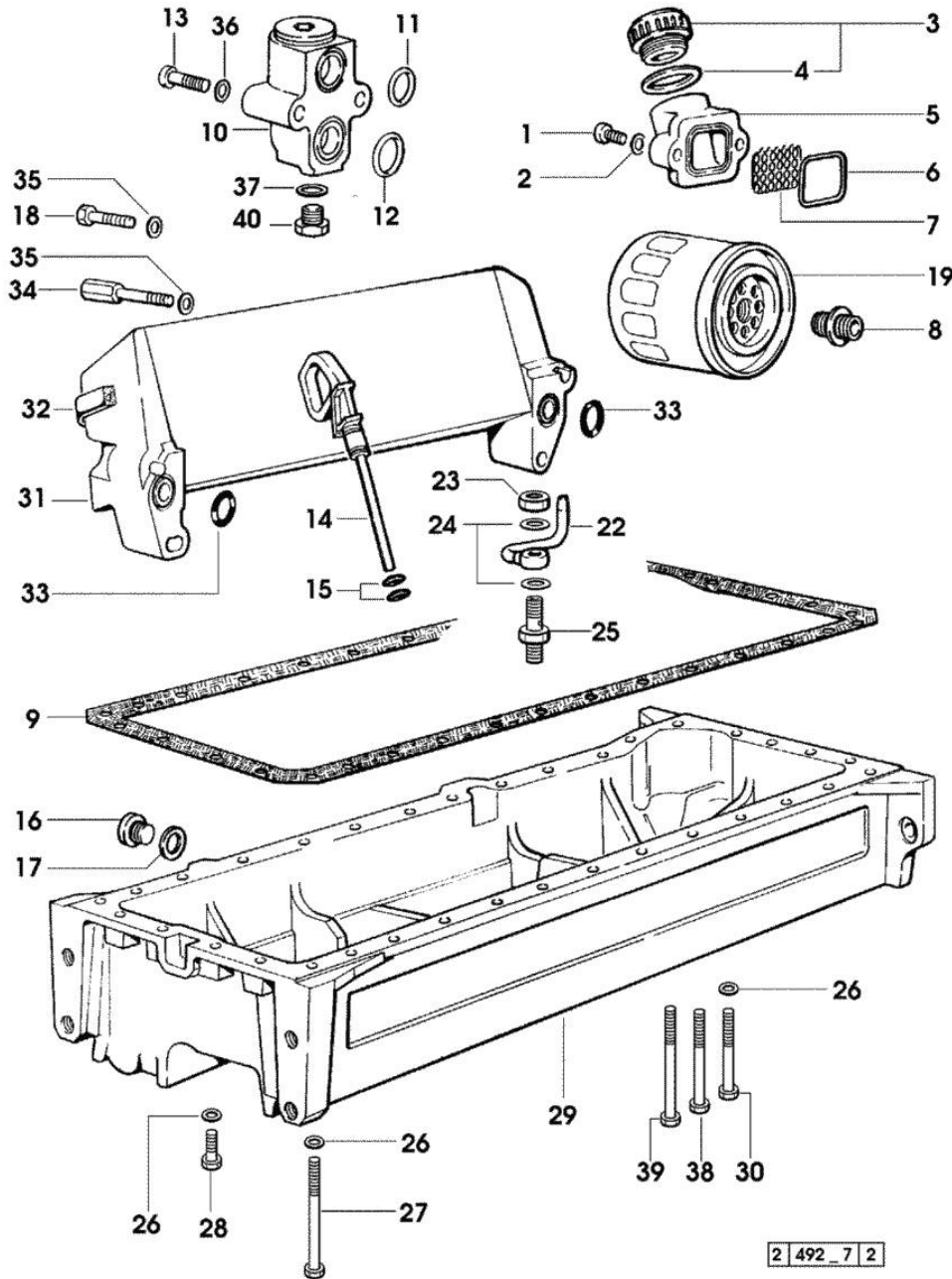

Fig.	P/n	QTY	Name
------	-----	-----	------

Notes:  
2000 <- X TITAN 160 [TITAN 145]

1	2.0312.206.2	2	screw m 8 p 1.25 x 20
2	2.1480.014.1	2	washer 8
3	0.041.1135.4	1	plug 1" gas
4	2.1569.072.0	1	gasket 32 x 39.5 x 2
5	0.065.1565.0/10	1	pipe union
6	2.1539.042.0	1	special oil seal 47.35x1.78
7	0.065.1567.0/10	1	filter
8	2.3339.307.0	2	pipe fitting m 22 p.1.5-3/4"
9	0.007.0849.0/10	1	gasket
10	0.065.1581.4/20	1	valve
11	2.1539.048.0	1	special oil seal 20.35x1.78
12	2.1539.072.0	1	special oil seal 23.52 x 1.78
13	2.0312.215.1	2	screw m 8 p.1.25 x 45
14	0.080.1513.2/10	1	dipstick
15	2.1539.065.0	2	special oil seal 8.73 x 1.78
16	2.3199.001.2	1	plug 1/2" gas
17	2.1560.054.0	1	gasket 21 x 26
18	2.0112.221.2	2	screw m 8 p.1.25 x 60
19	2.4419.340.0	2	oil filter element
22	0.007.0638.2	6	sprayers
23	2.1099.108.2	6	special nut m 10 p.1
24	2.1560.006.0	12	gasket 10.2 x 16
25	2.3249.022.2	6	pipe fitting m 10 p.1
26	2.1470.004.2	34	lock washer 8
27	2.0112.237.2	2	screw m 8 p.1.25x140
28	2.0112.215.2	25	screw m 8 p.1.25 x 40
29	0.007.1311.0/10	1	oil sump
30	2.0112.229.2	3	screw m 8 p.1.25 x 100
31	0.007.0775.3	1	radiator
32	0.007.0878.0	2	gasket
33	2.1539.048.0	2	special oil seal 20.35x1.78
34	2.0399.153.2	2	screw m 8 p.1.25
35	2.1480.014.1	2	washer 8
36	2.1480.014.1	2	washer 8
37	2.1560.010.0	1	gasket 14.2 x 20
38	2.0112.235.2	2	screw m 8 p.1.25 x 130
39	2.0112.241.2	4	screw m 8 p.1.25 x 160
40	2.3110.403.1	1	plug m 14 p.1.5x12

Section: ENGINE  
**LUBRICATION**

492 - 8 1

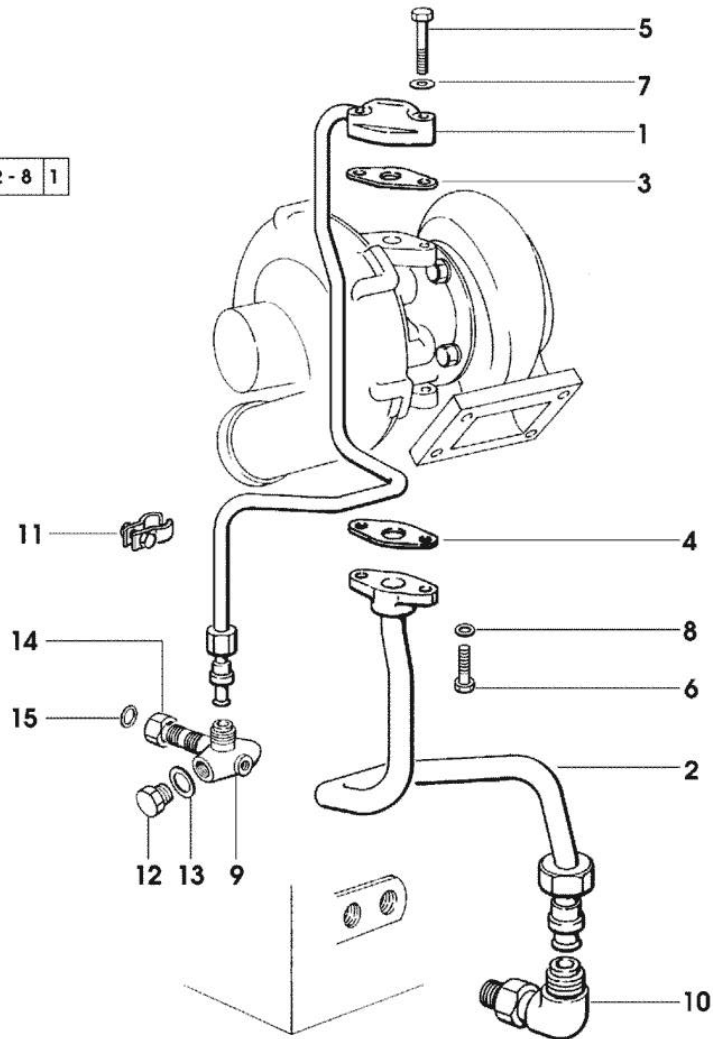

Fig.	P/n	QTY	Name
------	-----	-----	------

Notes:  
 [TITAN 145]

1	0.007.1300.3	1	tube
2	0.007.1301.3	1	tube
3	0.052.1557.0	1	gasket
4	0.052.1558.0/10	1	gasket
5	2.0312.212.2	2	screw m 8 p.1.25 x 35
6	2.0112.207.2	2	screw m 8 p 1.25 x 20
7	2.1480.014.1	2	washer 8
8	2.1470.004.2	2	lock washer 8
9	2.3339.673.0/10	1	pipe fitting
			* 1567 <= X TITAN 160
			* 1649 <= X TITAN 190
			- N.1 - 2.3110.403.7 - 2.1560.009.0
			2.1019.129.2/10 - 2.1530.038.0
10	2.3264.021.2	1	pipe fitting m 22 p.1.5 - 1" 1/16
11	0.007.1317.4	1	bracket
12	2.3110.403.7	1	plug m 14 p.1.5
13	2.1560.010.0	1	gasket 14.2 x 20
14	2.1019.129.2/10	1	nut m 18 p.1.5x12
15	2.1530.038.0	1	oil seal 15.54x2.62

Section: ENGINE  
LUBRICATION

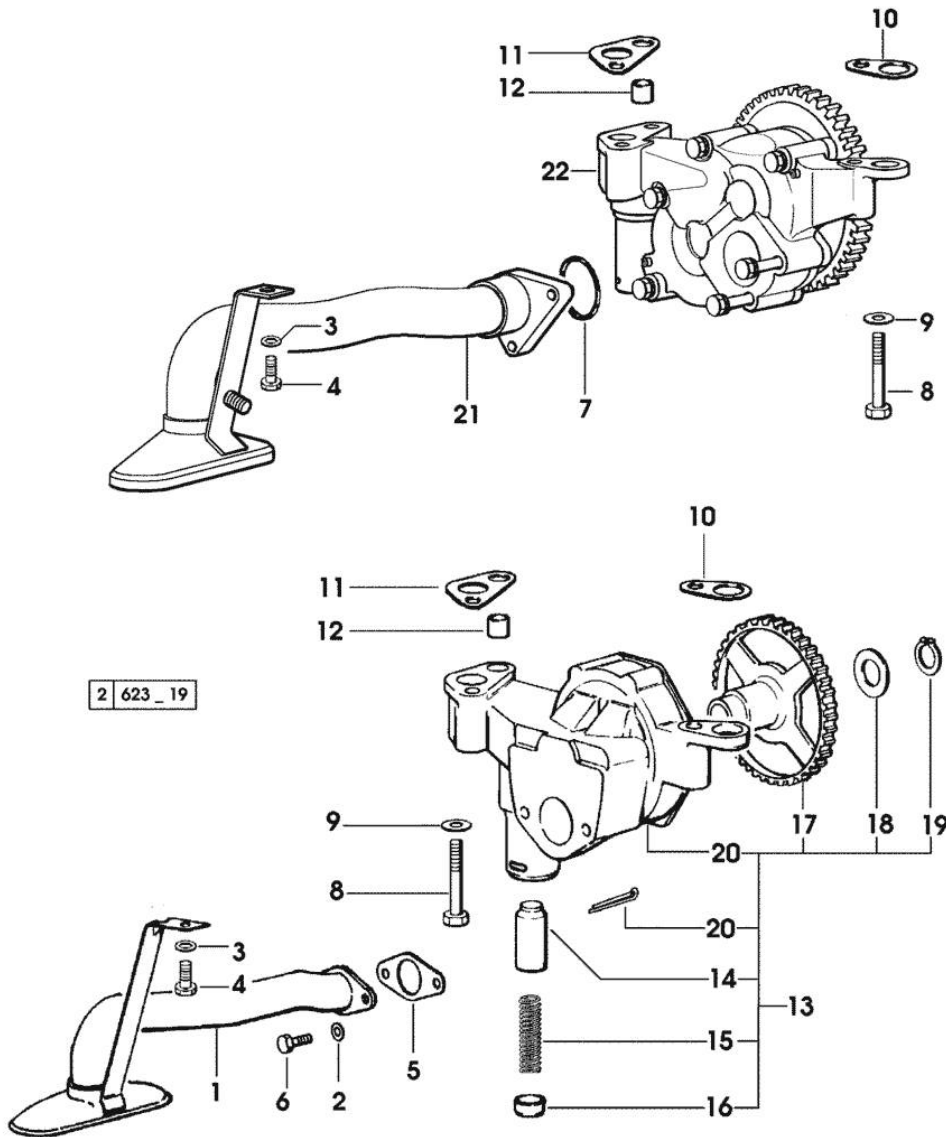

Fig.	P/n	QTY	Name
<b>Notes:</b> [TITAN 145]			
1	0.007.1312.3	1	tube (...) <-
2	2.1470.004.2	2	lock washer 8
3	2.1470.004.2	1	lock washer 8
4	2.0112.205.2	1	screw m 8 p.1.25 x 16
5	0.007.0997.0	1	gasket (...) <-
6	2.0112.207.2	2	screw m 8 p 1.25 x 20
7	2.1539.153.0	1	oil seal 32.99x2.6 -> (...)
8	2.0112.322.2	3	screw m 10 p.1.5x65
9	2.1310.006.2	3	flat washer 10.5x21
10	0.007.0972.0	2	shim
11	0.007.0973.0	2	shim
12	0.007.0867.0	1	bush
13	0.000.0000.1	1	cannot be supplied * (...) <- - N.1 - 010.0194.4/30 - 011.0087.4 - 2.1539.153.0
14	0.007.1371.0	1	piston
15	0.007.1373.0	1	spring
16	0.007.1372.0	1	cup
17	0.007.1438.0/10	1	gear
18	0.007.1437.0	1	washer
19	0.007.1436.0	1	circlip
20	0.000.0000.1	1	cannot be supplied
21	0.011.0087.4	1	tube -> (...)
22	0.010.0194.4/30	1	oil pump -> (...) ☞ 0.010.0194.4/30 ☞ 01.00.40

Section: ENGINE

**OIL PUMP**

Fig.	P/n	QTY	Name
------	-----	-----	------

**Notes:**

[TITAN 145]

1	0.010.0194.4/30	1	oil pump ☞ 0.010.0194.4/30
2	0.007.0866.3/10	1	valve
3	0.010.1709.0	1	gear z=8
4	2.0112.220.2	2	screw m 8 p.1.25x55
5	2.1475.002.7	6	washer 8.4
6	2.0112.219.2	2	screw m 8 p.1.25x55
7	0.010.0195.3/20	1	cover
8	2.1410.064.7	1	circlip
9	0.010.1708.0/20	1	gear z=8
10	2.1651.204.0	1	pin 3x10
11	0.000.0000.1		cannot be supplied
12	0.000.0000.1		cannot be supplied
13	2.1560.020.0	1	copper gasket 24.3x32
14	2.0112.217.2	2	screw m 8 p.1.25 x 45
15	2.1630.608.0	2	pin 6x16
16	0.000.0000.1		cannot be supplied

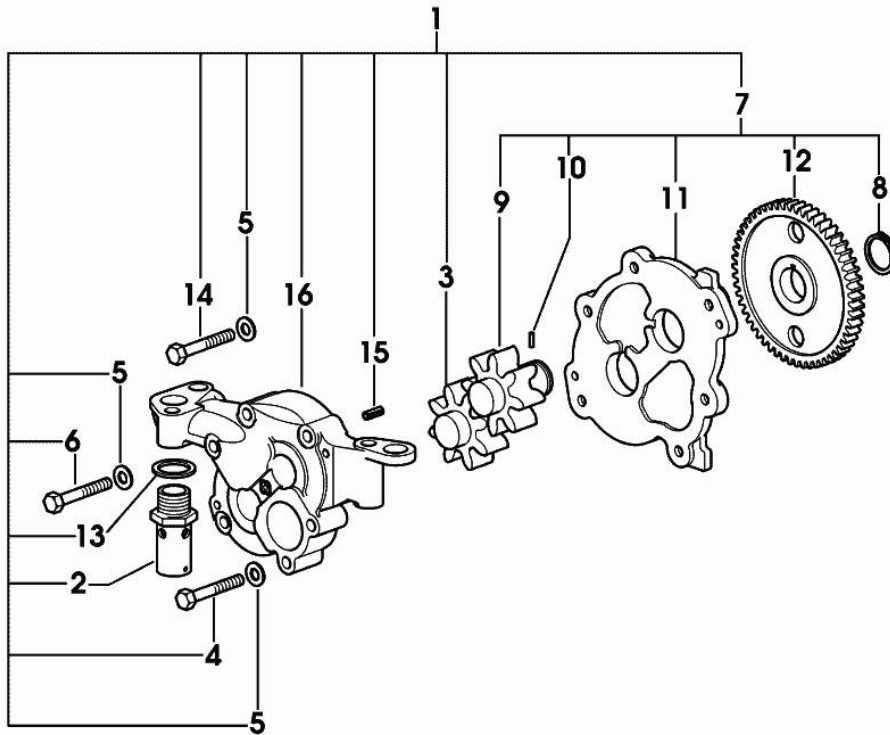

0\_010\_0194\_4\_30

Section: ENGINE  
**LUBRICATION**

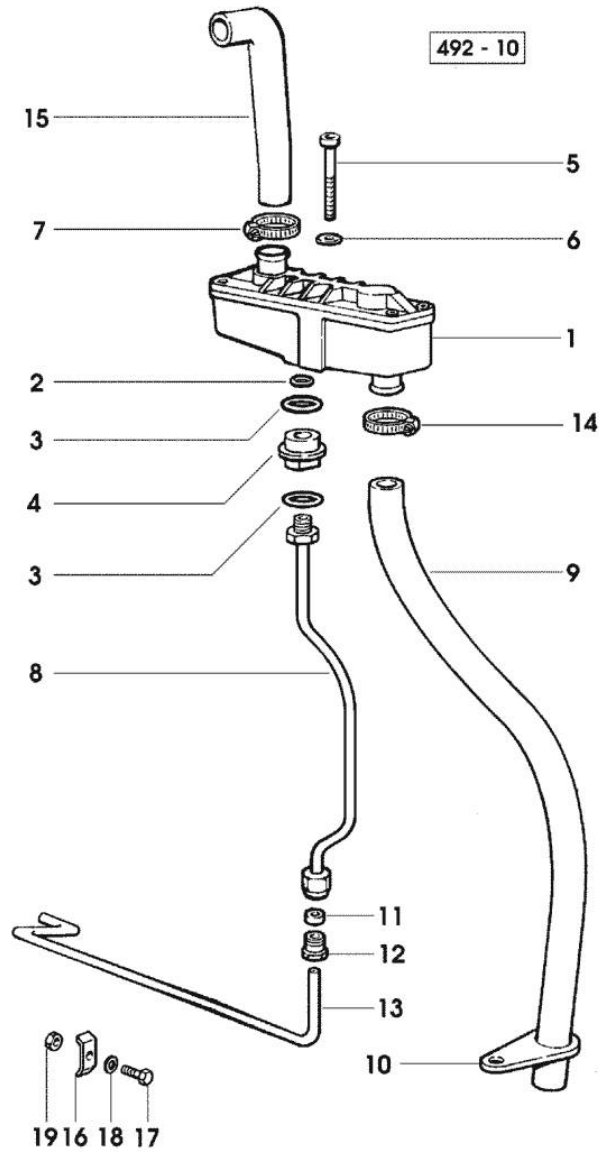

Fig.	P/n	QTY	Name
------	-----	-----	------

Notes:  
 [TITAN 145]

1	0.075.1557.4	1	sediment bowl ☞ 01.00.49
2	2.1560.008.0	1	gasket 12.2 x 18
3	2.1539.072.0	2	special oil seal 23.52 x 1.78
4	0.075.1553.0	1	bush
5	2.0312.221.2	2	screw m 8 p.1.25x75
6	2.1480.014.1	2	washer 8
7	2.6859.086.0	2	clamp
8	0.007.0861.0	1	tube
9	0.075.1554.0	1	tube
10	0.075.1151.0	1	bracket
11	2.3350.003.1	1	nosepiece 8
12	2.3339.418.1	1	pipe fitting m 12 p.1
13	0.007.0970.0	1	tube
14	2.6859.086.0	1	clamp
15	0.075.1453.0/10	1	tube
16	0.002.8816.0	1	small plate
17	2.0112.007.2	1	screw m 6 p.1 x 20
18	2.1310.002.2	1	flat washer 6.4x12.5
19	2.1011.103.2	1	nut m 6 p.1

**OIL VAPORS SEDIMENT BOWL PARTS**

Fig.	P/n	QTY	Name
------	-----	-----	------

Notes:  
[TITAN 145]

1	0.075.1557.4	1	sediment bowl
2	0.075.1558.3	1	old part number
3	0.075.1559.0	1	gasket
4	0.075.1557.3	1	old part number
5	2.0351.203.2	4	screw 3.5x9.5

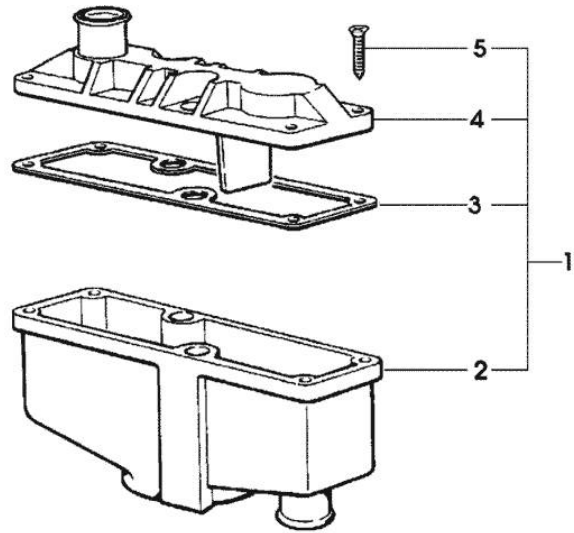

075.1557.4
492 - 11



**Suggest:**

**For more complete manuals. Please go to the home page.**

**<https://www.ebooklibonline.com>**

**If the above button click is invalid. Please download this document first, and then click the above link to download the complete manual.**

**Thank you so much for reading**

Section: ENGINE  
**FUEL SUPPLY SYSTEM**

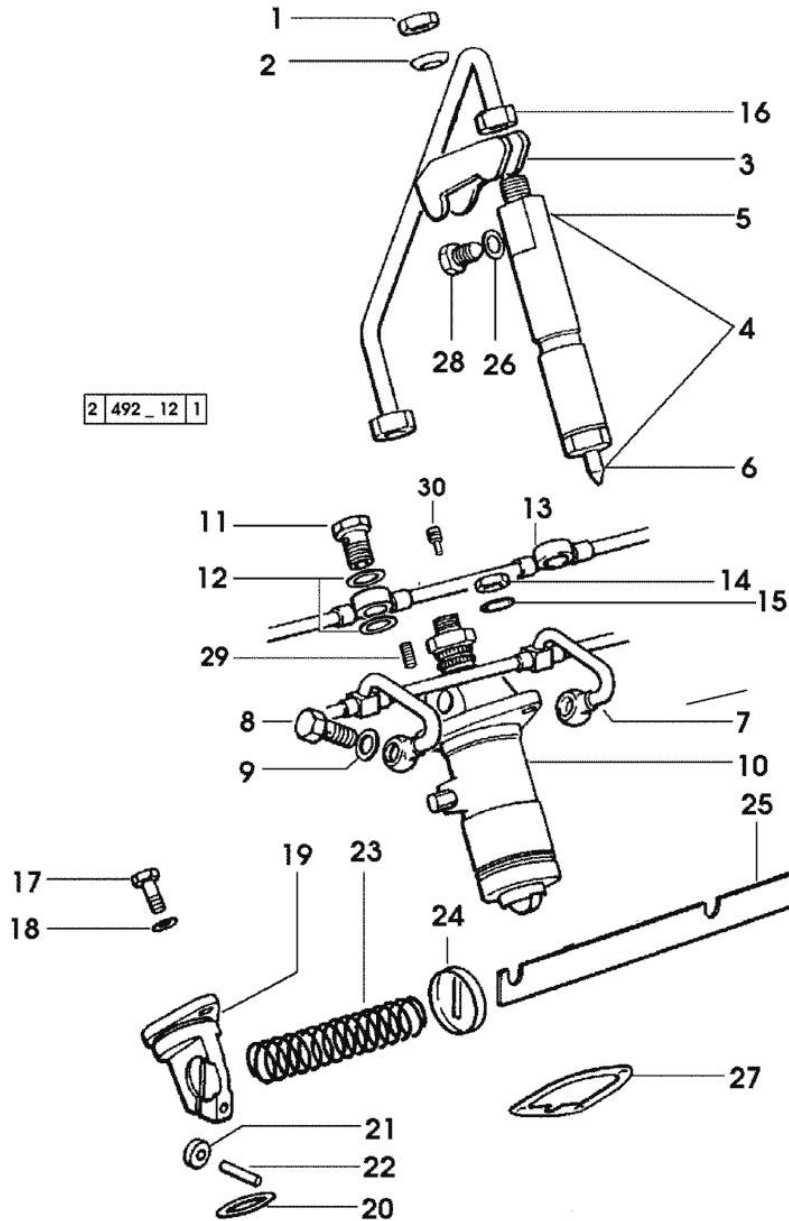
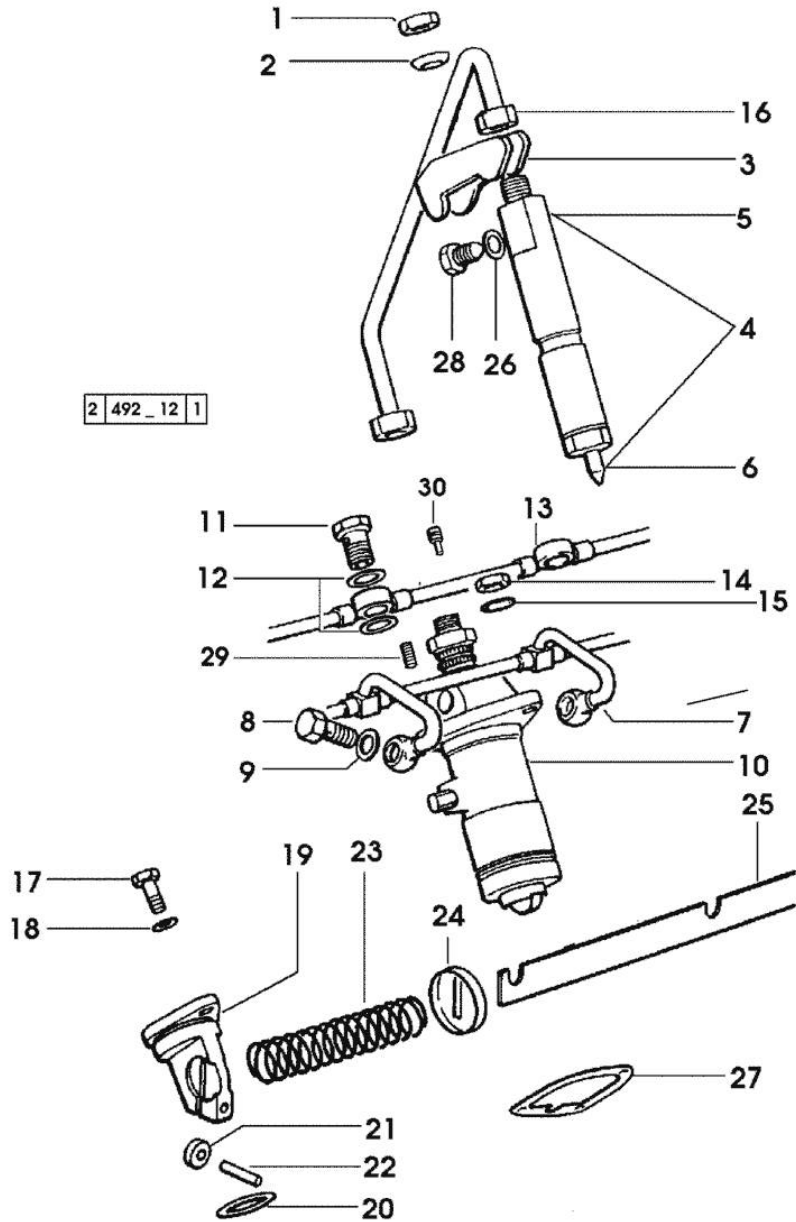

Fig.	P/n	QTY	Name
<b>Notes:</b>			
[TITAN 145]			
1	2.1011.421.2	6	nut m 10 p.1.25
2	2.1599.454.0	6	shoulder ring 10.5x17x7.5
3	0.011.5275.0/20	6	bracket
4	2.4719.280.0	6	injector assembly BOSCH
4	2.4719.330.0	6	injector assembly - X TITAN 160 - TITAN 190 - EXPORT U.S.A.
5	2.4719.190.0	6	nozzle holder BOSCH ☞ 2.4719.190.0 ☞ 01.00.73
6	2.4729.140.0	6	nozzle BOSCH
6	2.4729.180.0/10	6	nozzle - X TITAN 160 - TITAN 190 - EXPORT U.S.A.
7	0.007.1789.3/10	1	tube
8	2.3339.001.2	6	pipe union m 10 p.1x27
9	2.1560.005.0	12	copper gasket 10.2 x 14
10	2.4619.060.0/10	6	injector pump * 1408 <= X TITAN 160 * 1516 <= X TITAN 190 - N.1 - 2.0512.102.7 ☞ 2.4619.060.0/10 ☞ 01.00.70
11	2.3339.118.1	6	pipe union m 12 p.1.5
12	2.1560.008.0	12	gasket 12.2 x 18
13	0.007.0091.3	1	tube 2000 <- X TITAN 160
13	0.007.1393.3	1	tube -> 2001 X TITAN 160 - X TITAN 190
14	2.1011.405.2	18	nut m 8 p.1
15	2.1599.458.0/10	18	shoulder ring 8.4x18x2
16	0.078.1650.3	6	tube
17	2.0112.207.2	3	screw m 8 p 1.25 x 20
18	2.1470.004.2	3	lock washer 8
19	0.065.1693.0/20	3	support
20	2.1530.072.0	3	oil seal 26.70x1.78
21	0.065.1660.0	2	roller
22	2.1652.507.0	2	pin 6x16
23	2.4019.314.1/20	1	spring 21.5x76x1
24	0.065.1659.0	1	stop

**FUEL SUPPLY SYSTEM**

Fig.	P/n	QTY	Name
25	0.075.1613.3/10	1	rod
26	2.1560.001.0	6	gasket 6.2x10
27	0.065.1655.0/10	12	shim mm 0.1
27	0.065.1656.0/10	24	shim mm 0.20
28	2.3119.024.2	6	plug m 6
29	2.0512.102.7	6	screw m 6 p.1 x 8
30	2.3199.270.0		plug 5.9x7.8



**<https://www.ebooklibonline.com>**

Hello dear friend!

Thank you very much for reading.

Enter the link into your browser.

The full manual is available for immediate download.

**<https://www.ebooklibonline.com>**