

Section: ENGINE
CRANKCASE

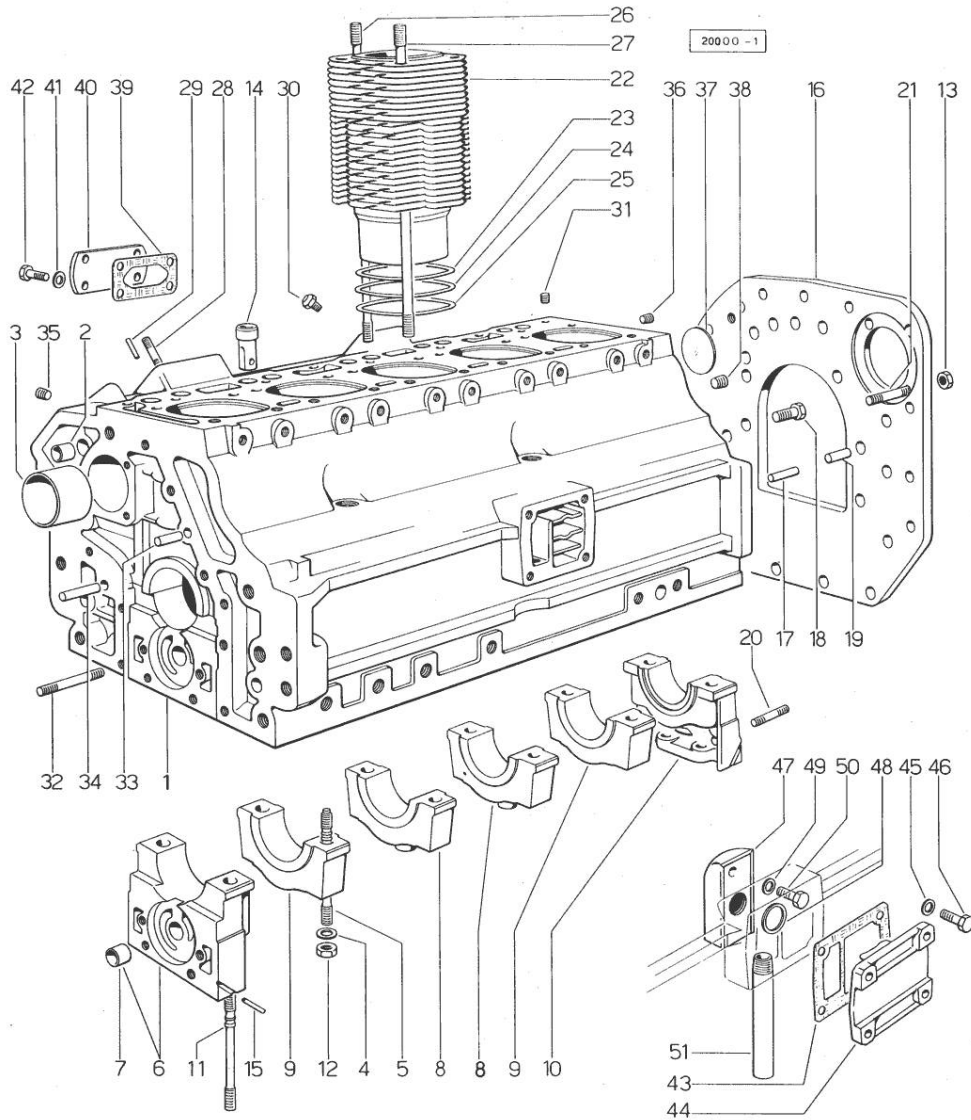

Fig.	P/n	QTY	Name
Notes: [TIGER 100]			
0	0.042.0050.6	1	gasket set
1	0.048.1110.4/60	1	crankcase => 3109
1	0.048.1110.6	1	crankcase 3108 <=
2	2.1559.111.0	2	bushing 12x14x10
3	0.037.1155.0	1	bushing
4	2.1599.144.0	12	shoulder
5	0.029.1117.0	8	stud bolt
6	0.036.1112.3	1	support
7	2.1559.090.0/10	1	bushing 14.24x19.06x27
8	0.037.1114.0	2	support
9	0.029.1113.0	2	support
10	0.029.1116.0	1	support
11	0.021.1157.0	4	stud bolt
12	2.1019.026.1	12	special nut m 12 p.1.5
13	2.1011.207.2	2	nut m 12 p.1.5
14	0.044.1156.0	10	special bushing
15	0.029.1154.0	4	gasket
16	0.044.1159.0	1	flange => 1682
16	0.047.1130.0/10	1	flange 1681 <=
17	2.1653.708.0	2	pin 8x18
18	2.0112.513.1	11	screw m 14 p.2 x 35
19	2.1652.911.0	2	cylindrical plug 12x25
20	2.0432.153.1	3	stud bolt m 10 p.1.5 / p.1.25 x 20
21	2.0432.255.1	2	stud bolt m 12 p.1.75 - 12 p.1.25x25
22	0.044.1120.0/10	5	engine cylinder
23	2.1589.052.0	10	shoulder ring 115x123x0.2
24	2.1589.051.0	5	shoulder ring 116x123x0.1
25	2.1569.076.0	5	gasket 116x123x0.5
26	0.041.1123.0	5	stud bolt m 10
27	0.039.1122.0	20	stud bolt m 12 p.1.5x310
28	2.0432.003.1	8	stud bolt m 8 p.1.25 / p.1 x 20
29	2.1653.306.0	2	pin
30	0.041.1151.3/10	5	sprayer nozzle
31	2.3130.001.1	4	plug 1/8" gas
32	2.0432.025.1	2	stud bolt m 8 p 1.25-1x100
33	2.1653.711.0	1	pin
34	2.1699.114.0	1	pin 8x55

Section: ENGINE
CRANKCASE

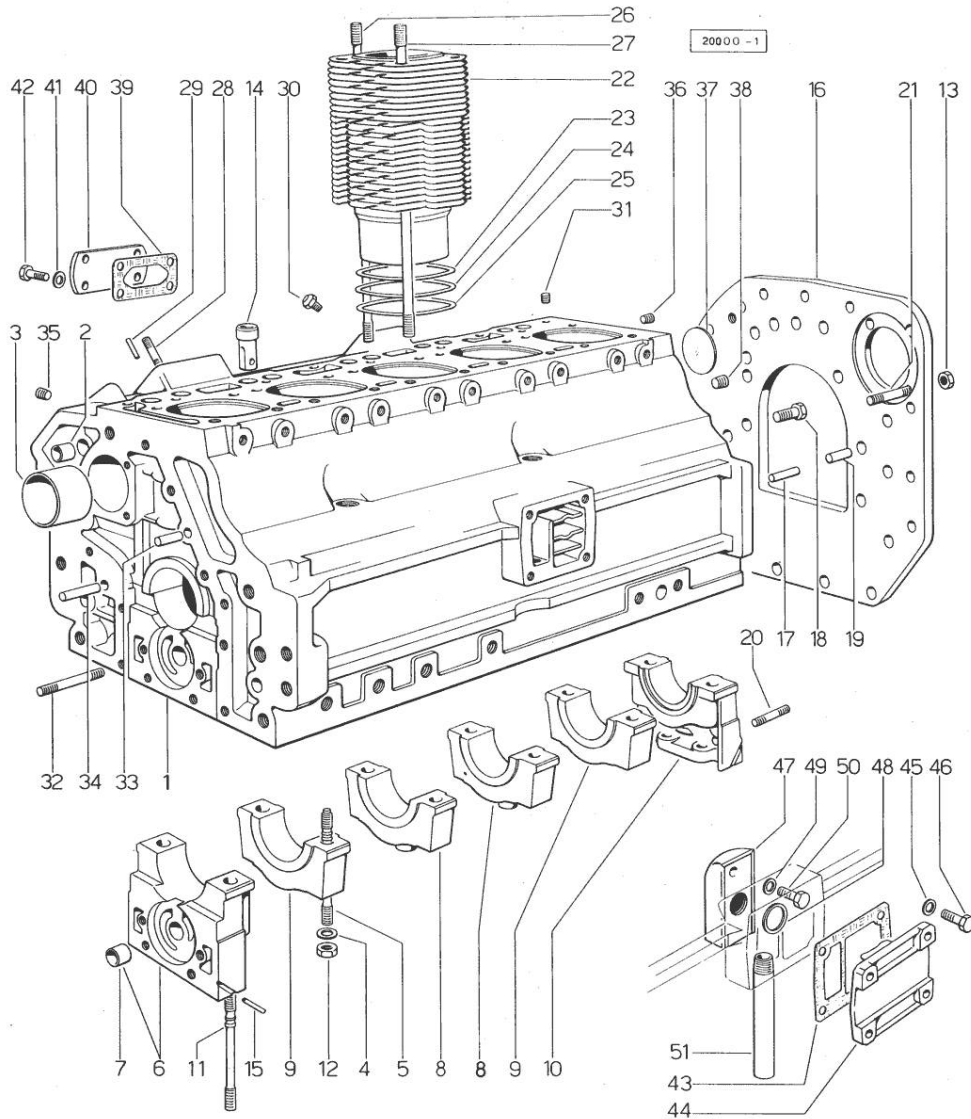

Fig.	P/n	QTY	Name
35	2.3139.001.1	5	plug
36	2.3130.002.1	1	plug 1/4" gas
37	2.3170.022.1	1	expansion plug 60
38	2.3130.003.1	2	plug 3/8" gas
39	0.044.1151.0	2	gasket
40	0.044.1150.0	2	cover
41	2.1310.004.2	8	flat washer 8.4x17
42	2.0112.204.2	8	screw m 8 p.1.25x14
43	0.044.1153.0/10	1	gasket
44	0.044.1154.0	1	cover
45	2.1480.014.1	4	washer 8
46	2.0112.209.2	4	screw m 8 p 1.25 x 25
47	0.044.1155.2/20	1	cover
48	0.045.1150.0	1	oil seal
49	2.1480.014.1	1	washer 8
50	2.0312.206.2	1	screw m 8 p 1.25 x 20
51	0.044.1152.0	1	tube

Section: ENGINE
TIMING CASE

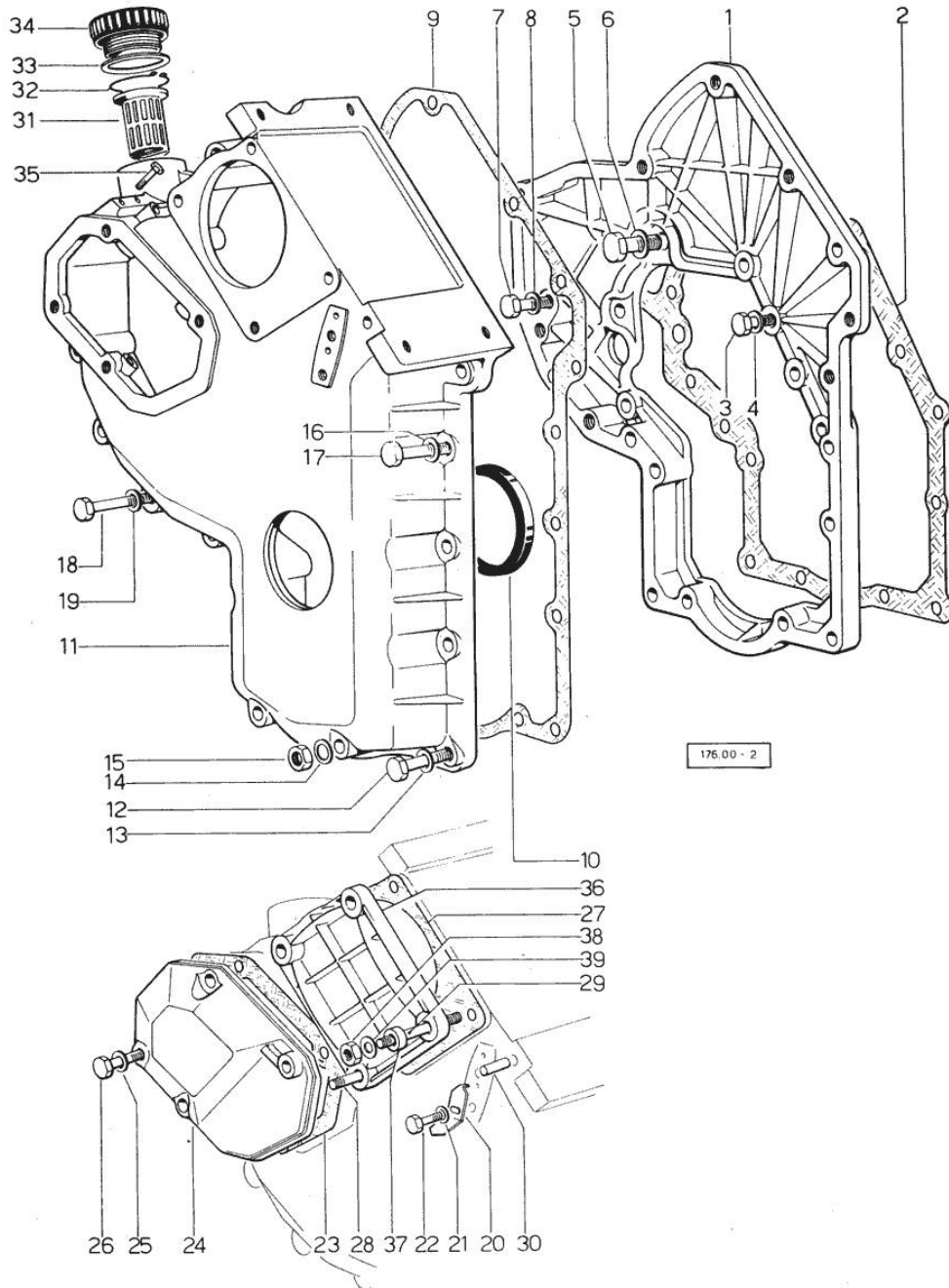

Fig.	P/n	QTY	Name
------	-----	-----	------

Notes:
[TIGER 100]

1	0.048.1131.0	1	flange
2	0.041.1153.0	1	gasket
3	2.0112.209.2	5	screw m 8 p 1.25 x 25
4	2.1480.014.1	5	washer 8
5	2.0119.034.1	1	screw m 14 p.2x20
6	2.1560.010.0	1	gasket 14.2 x 20
7	2.0112.207.2	1	screw m 8 p 1.25 x 20
8	2.1480.014.1	1	washer 8
9	0.041.1152.0	1	gasket
10	2.1519.010.0	1	special oil seal 58x80x10
11	0.048.1132.0/10	1	guard => 2277
11	0.048.1132.6	1	guard 2276 <=
12	2.0112.217.2	5	screw m 8 p.1.25 x 45
13	2.1480.014.1	5	washer 8
14	2.1560.003.0	2	copper gasket 8.2 x 12
15	2.1011.405.2	2	nut m 8 p.1
16	2.1480.014.1	2	washer 8
17	2.0112.211.2	2	screw m 8 p.1.25 x 30
18	2.0112.222.1	4	screw
19	2.1480.014.1	4	washer 8
20	0.041.1158.0	1	index
21	2.1310.004.2	1	flat washer 8.4x17
22	2.0112.204.2	1	screw m 8 p.1.25x14
23	0.048.1152.0	1	gasket
24	0.048.1150.0	1	cover 2276 <=
24	0.048.1150.0/10	1	old part number => 2277
25	2.1560.003.0	4	copper gasket 8.2 x 12
25	2.1560.005.0	4	copper gasket 10.2 x 14
26	2.0112.215.2	4	screw m 8 p.1.25 x 40 2276 <=
26	2.0112.315.2	4	screw m 10 p.1.5 x 40 => 2277
27	0.041.1154.0	1	gasket
28	2.0432.015.1	1	stud bolt m 8 p 1.25 - m 8 p. 1x50
29	2.0432.028.1	3	stud bolt m 8 p.1.25-1x130
30	2.1653.717.0	1	pin 8 x 40
31	0.041.1159.0/10	1	filter

<https://www.ebooklibonline.com>

Hello dear friend!

Thank you very much for reading.

Enter the link into your browser.

The full manual is available for immediate download.

<https://www.ebooklibonline.com>

Section: ENGINE

TIMING CASE

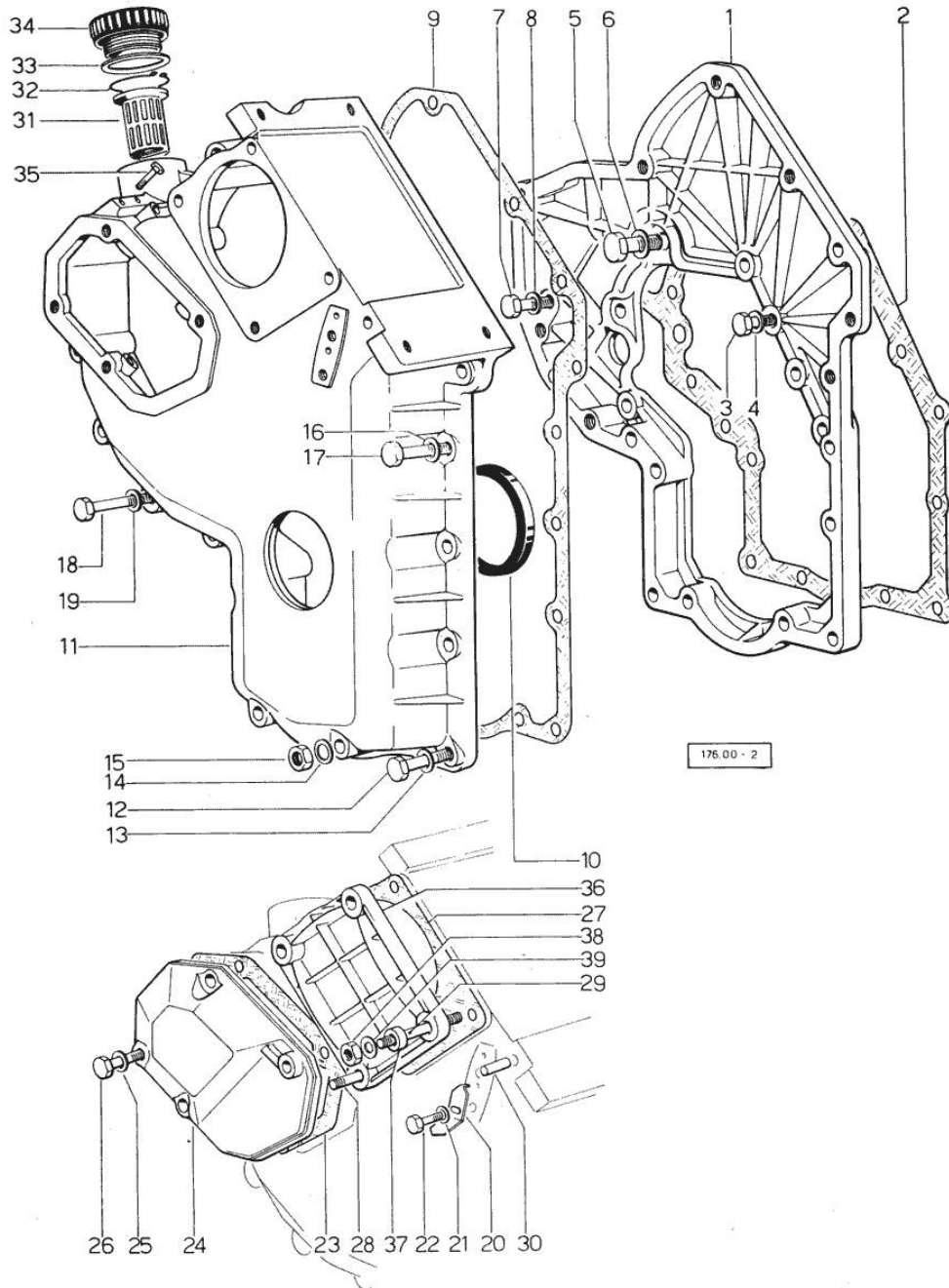

Fig.	P/n	QTY	Name
32	2.1411.012.1	1	circlip 30
33	2.1569.072.0	1	gasket 32 x 39.5 x 2
34	0.041.1135.0	1	plug
35	2.0119.081.2	2	screw
35	2.0439.055.1	2	stud bolt m 6 p.1 x 18
36	0.037.1151.0	1	cover
37	2.1579.191.0	4	spacer 8.5 x 18 x 20
38	2.1011.505.2	4	nut m 8 p.1
39	2.1310.004.2	4	flat washer 8.4x17

Section: ENGINE

CRANKSHAFT

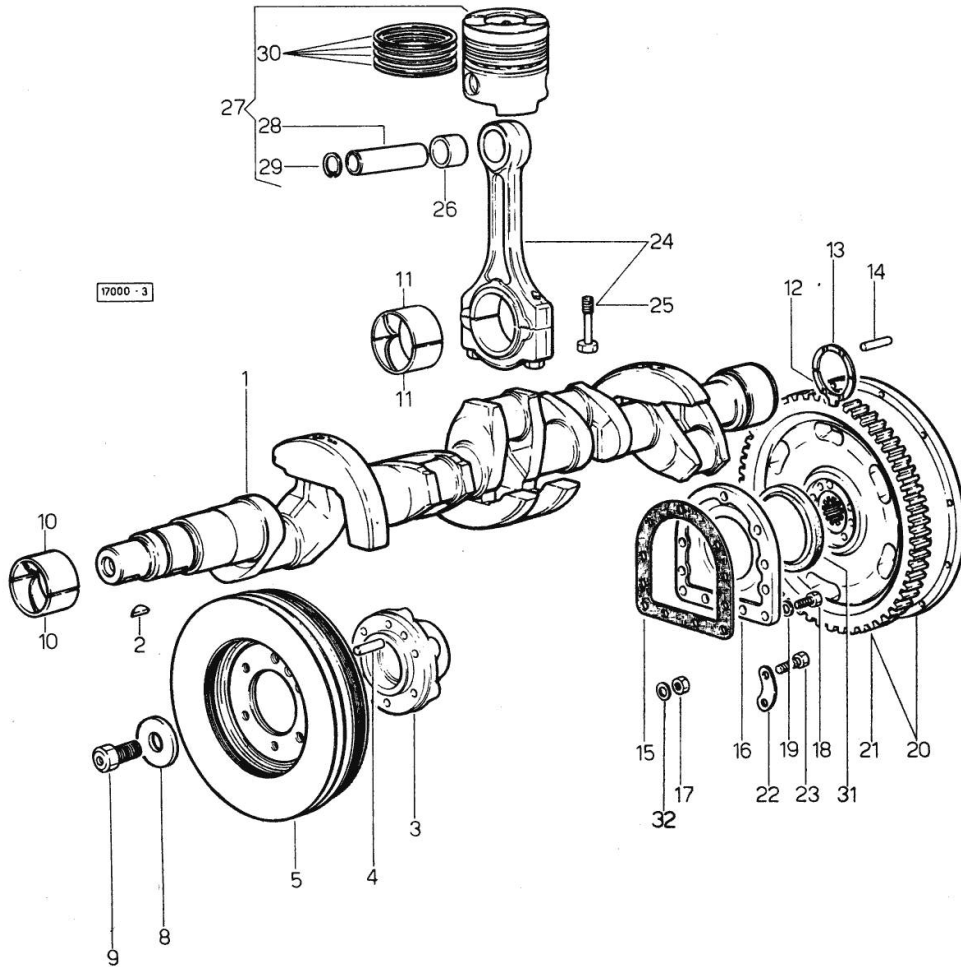

Fig.	P/n	QTY	Name
------	-----	-----	------

Notes:
[TIGER 100]

1	0.041.1210.4	1	crankshaft
2	2.1799.002.0	1	stick 10x13
3	0.037.1250.0/10	1	hub
4	2.1651.909.0	1	cylindrical plug 12 x 20
5	0.042.1246.3	1	antivibration pulley => 2759
5	0.048.1246.3/10	1	antivibration pulley 2758 <=
8	0.001.6020.0	1	shoulder
9	2.0129.032.2	1	screw m 24 p.2x45
10	0.029.0066.0	12	main half bushing - mm 1.00
10	0.029.1215.0/10	12	main half bushing
10	0.029.1215.7	12	main half bushing - mm 0.25
10	0.029.1215.8	12	main half bushing - mm 0.50
10	0.029.1215.9	12	main half bushing - mm 0.75
11	0.039.0068.0	10	con.rod half bushing - mm 1.016
11	0.039.1225.0	10	con.rod half bushing
11	0.039.1225.7	10	con.rod half bushing -mm 0.254
11	0.039.1225.8	10	con.rod half bushing -mm 0.508
11	0.039.1225.9	10	con.rod half bushing -mm 0.762
12	0.001.4547.0	2	shoulder ring + mm 0.05
12	0.001.4548.0	2	shoulder ring + mm 0.10
12	0.001.4549.0	2	shoulder ring + mm 0.15
12	0.042.1219.0	2	shoulder ring STANDARD
13	0.001.4544.0	2	shoulder ring + mm 0.05
13	0.001.4545.0	2	shoulder ring + mm 0.10
13	0.001.4546.0	2	shoulder ring + mm 0.15
13	0.042.1218.0	2	shoulder ring STANDARD
14	2.1652.915.0	2	cylindrical plug 12x35
15	0.029.1250.0	1	gasket
16	0.029.1240.0	1	flange
17	2.1011.421.2	2	nut m 10 p.1.25
18	2.0112.309.2	7	screw m 10 p.1.5 x 25
19	2.1480.015.1	7	washer 10
20	0.048.1241.3/10	1	flywheel
21	0.036.1242.0	1	crown wheel Z = 126, mm 15
22	2.1379.006.0	3	lock-tab 15x15x36,5
23	2.0122.517.7	6	screw m 14 p.1.5x45
24	0.052.1220.3	5	engine connecting rod
25	0.039.1250.0	10	screw m 14 p.1.5x63
26	0.002.4168.0	5	bearing

Section: ENGINE
CRANKSHAFT

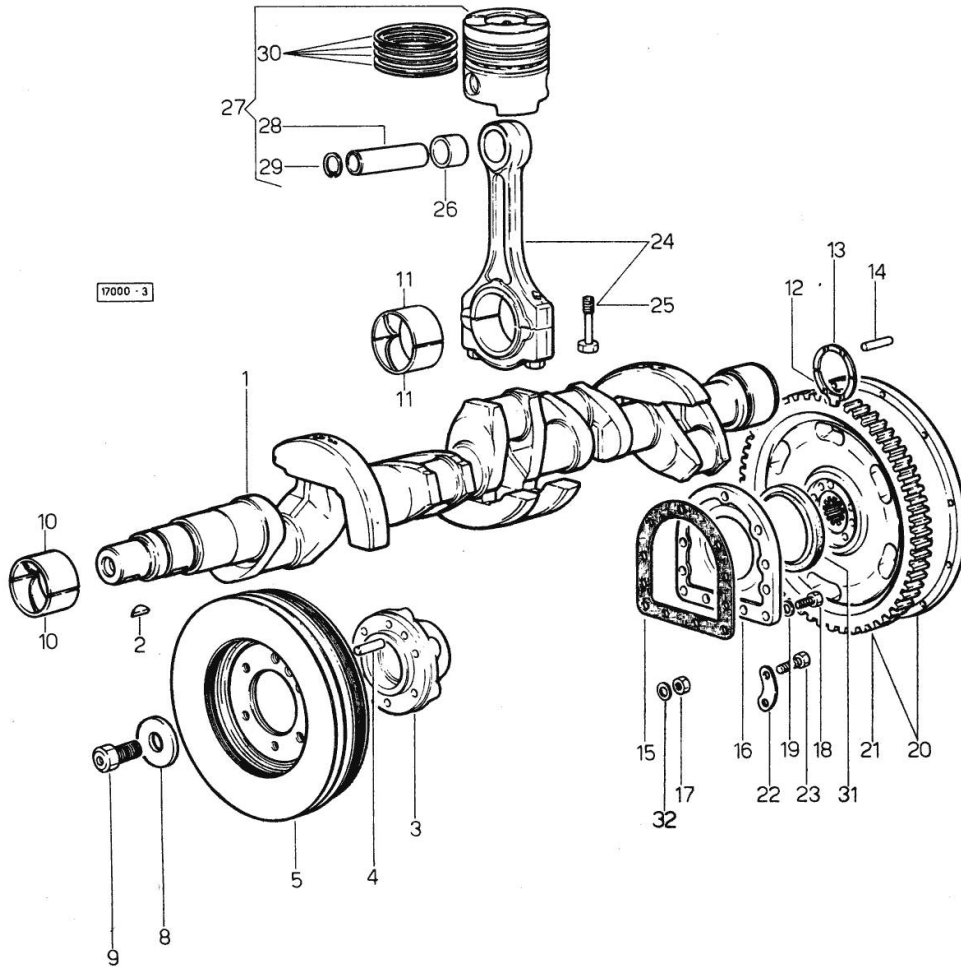

Fig.	P/n	QTY	Name
27	0.044.0060.6/10	5	complete piston STANDARD 2758 <=
27	0.044.0061.6	5	old part number + mm 0.5 2758 <=
27	0.044.0062.6	5	old part number + mm 1.0 2758 <=
27	0.046.0060.6/10	5	complete piston => 2759
27	0.046.0061.6	5	complete piston + mm 0.5 => 2759
27	0.046.0062.6	5	complete piston + mm 1.0 => 2759
28	0.038.1236.0	5	piston pin
29	2.1411.014.1	10	circlip 35
30	0.038.0052.6	5	piston ring set
30	0.038.0053.6	5	piston ring set + mm 0.5
30	0.038.0054.6	5	piston ring set + mm 1.0
31	2.1519.009.0	1	special oil seal
32	2.1560.006.0	2	gasket 10.2 x 16

Section: ENGINE

CAMSHAFT

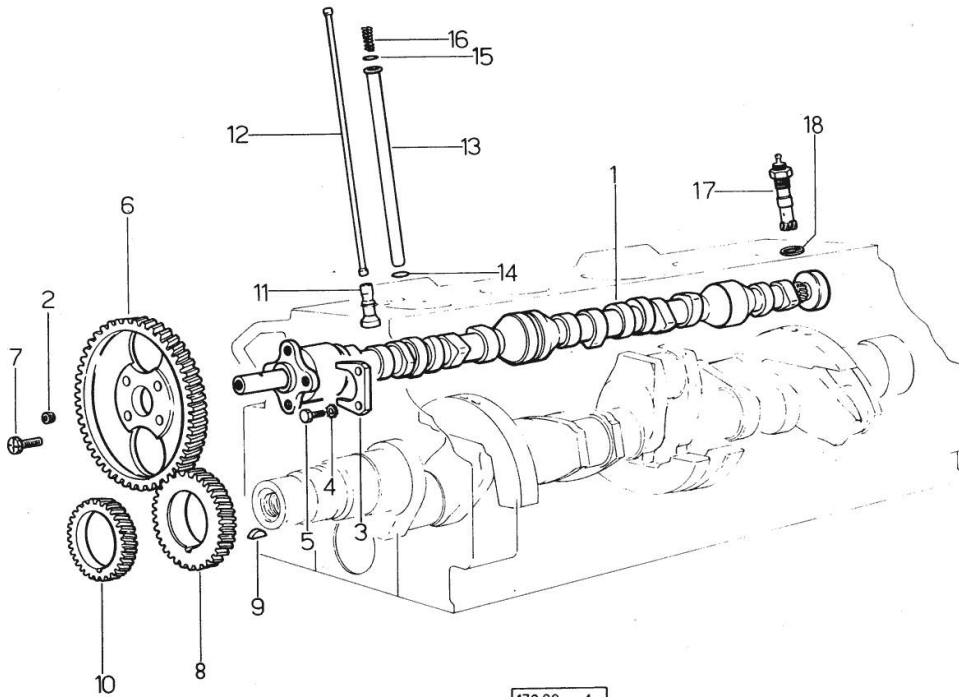

Fig.	P/n	QTY	Name
------	-----	-----	------

Notes:
[TIGER 100]

1	0.048.1310.0	1	camshaft
2	2.3130.001.1	1	plug 1/8" gas
3	0.027.1314.0	1	flange
4	2.1470.004.2	2	lock washer 8
5	2.0112.207.2	2	screw m 8 p 1.25 x 20
6	0.041.1321.0	1	gear z = 66
7	2.0139.005.1	4	screw m 10 p.1 x 25
8	0.040.1320.0	1	gear z = 33
9	2.1720.010.0	1	key 5x9
10	0.040.1323.0/10	1	gear Z = 38
11	0.044.1330.0/10	10	tappets
12	0.041.1331.3	10	rod
13	0.041.1332.0	10	sleeve
14	2.1539.020.0	10	special oil seal 13.95x2.62
15	2.1539.020.0	10	special oil seal 13.95x2.62
16	2.4019.162.1/20	10	spring 17.2x46x1.8
17	0.041.1355.3	1	transmission
18	2.1560.013.0	1	gasket 18.2x22

Section: ENGINE
CYLINDER HEAD

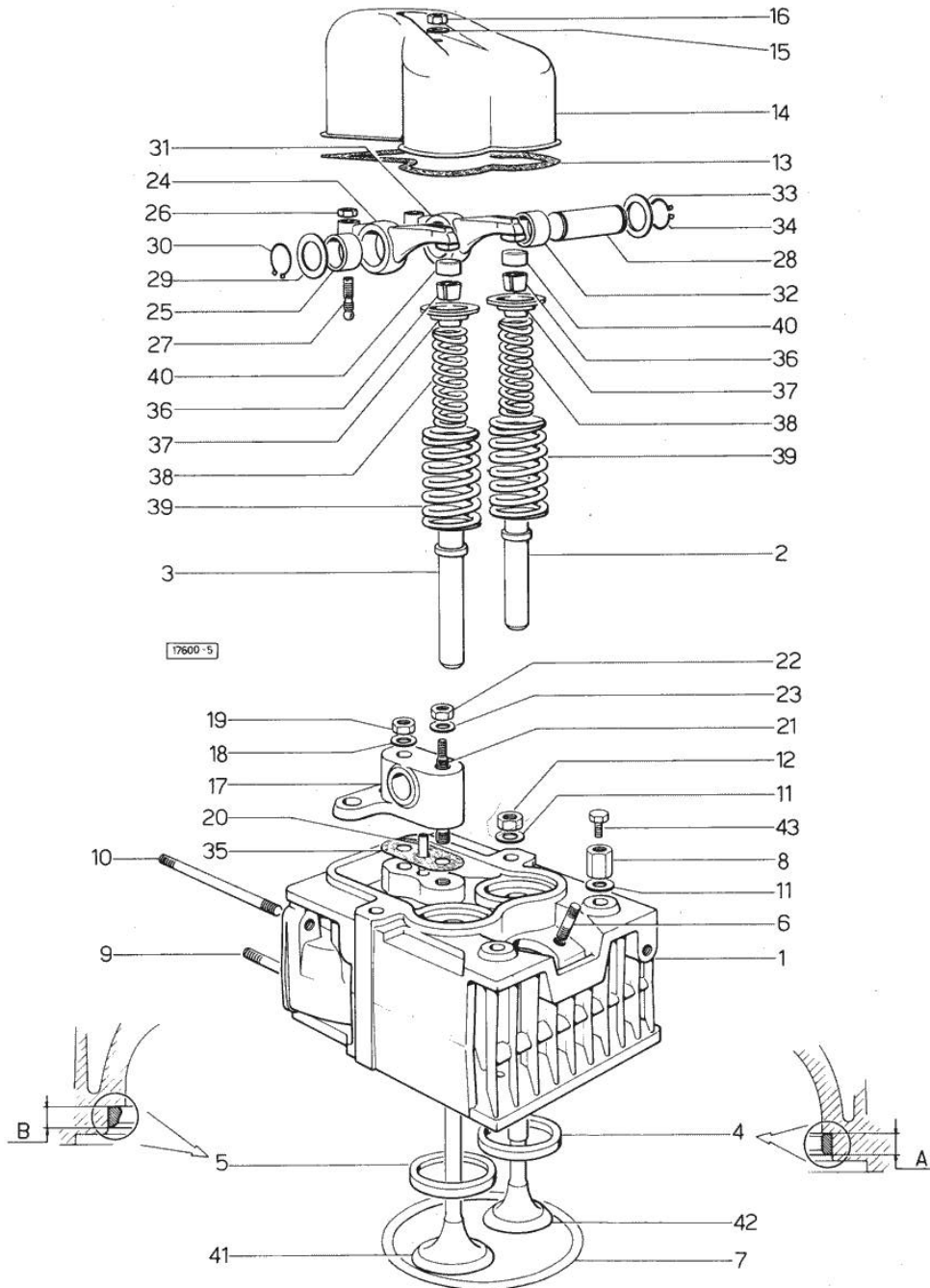

Fig.	P/n	QTY	Name
Notes: [TIGER 100]			
0	0.042.0057.6	1	gasket set - FOR 1 CYLINDER VALVE GRINDING AND PISTON RINGS REPLACEMENT
0	0.042.0058.6	1	gasket set - FOR GRINDING VALVES OF ONE CYLINDER
1	0.044.1450.3/30	5	engine head
2	0.037.1417.0/10	5	valve guide
3	0.037.1416.0	5	valve guide
4	0.037.1452.0	5	valve seat A=MM 6.4 - 2283 <= A=MM 6.2 - => 2284
4	0.037.1452.0/10	5	valve seat A=MM 6.4 - 2283 <= A=MM 6.2 - => 2284
5	0.037.1451.0	5	valve seat B=MM 6.4 - 2283 <= B=MM 6.2 - => 2284
5	0.037.1451.0/10	5	valve seat B=MM 6.4 - 2283 <= B=MM 6.2 - => 2284
6	2.0439.087.1	10	stud bolt
7	2.1569.078.0/10	5	gasket 106x118x0.5
8	2.1019.037.1	5	nut m 12 p.1.5x35
9	2.0432.007.1	9	stud bolt m 8 p.1.25 / p.1 x 30
10	2.0432.026.1	5	stud bolt m 8 p.1.25 - 1.00 x 110
11	2.1599.144.0	20	shoulder
12	2.1019.025.1	15	special nut
13	0.029.1450.0	5	gasket
14	0.039.1440.2	5	cap
15	2.1560.004.0	5	copper gasket 8.2 x 14
16	2.1099.056.1	5	special nut m8 p.1
17	0.041.1430.0	5	support
18	2.1599.160.0	5	washer 10.5x19x4
19	2.1099.035.1	5	special nut
20	0.029.1452.0	5	tube
21	0.039.1451.0	5	stud bolt
22	2.1011.421.2	5	nut m 10 p.1.25
23	2.1310.006.2	5	flat washer 10.5x21
24	0.002.5937.3/30	5	rocker arm
25	2.1559.021.0/40	5	bushing 15x19x22
26	2.1011.405.2	10	nut m 8 p.1
27	0.021.1434.0	10	screw
28	0.041.1431.0	5	pin
29	2.1599.019.0	5	shoulder ring 19.5x31x2
30	2.1410.055.1	5	circlip 19



Suggest:

For more complete manuals. Please go to the home page.

<https://www.ebooklibonline.com>

If the above button click is invalid. Please download this document first, and then click the above link to download the complete manual.

Thank you so much for reading

Section: ENGINE
CYLINDER HEAD

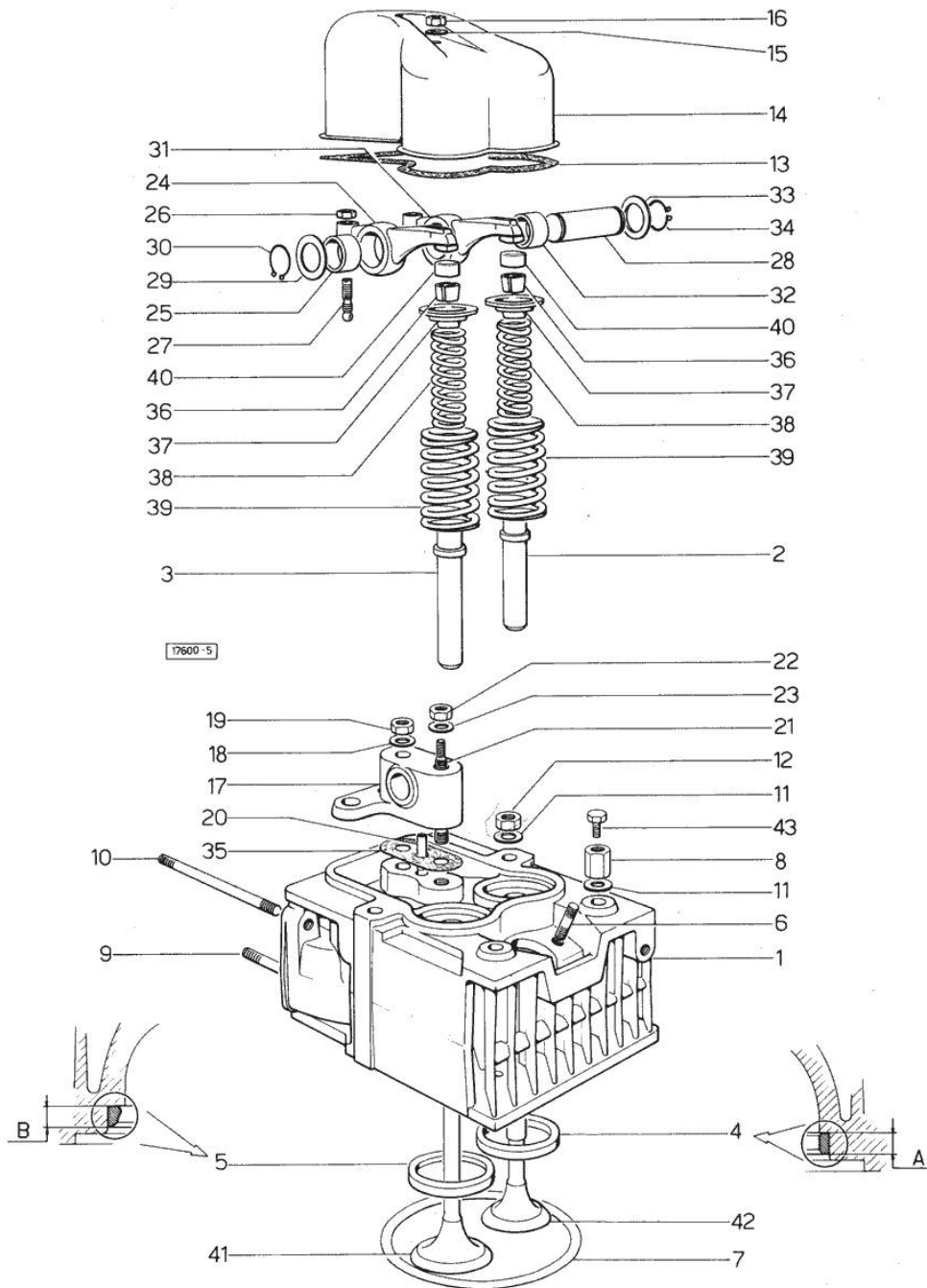

Fig.	P/n	QTY	Name
31	0.002.5936.3/40	5	rocker arm
32	2.1559.021.0/40	5	bushing 15x19x22
33	2.1599.019.0	5	shoulder ring 19.5x31x2
34	2.1410.055.1	5	circlip 19
35	0.034.1450.0	5	tappet gasket
36	0.002.9193.0	10	conical valve cotter
37	0.002.9215.0	10	cup
38	2.4019.194.0	10	spring 22.70x50.7x2.1
39	2.4019.193.0	10	spring 36.15x55.2x3.2
40	0.021.1453.0/20	10	small cover
41	0.053.1420.0	5	inlet valve
42	0.039.1421.0	5	exhaust valve Ø mm 9
43	2.0119.053.1	3	screw

Section: ENGINE
LUBRICATION 2276 <=

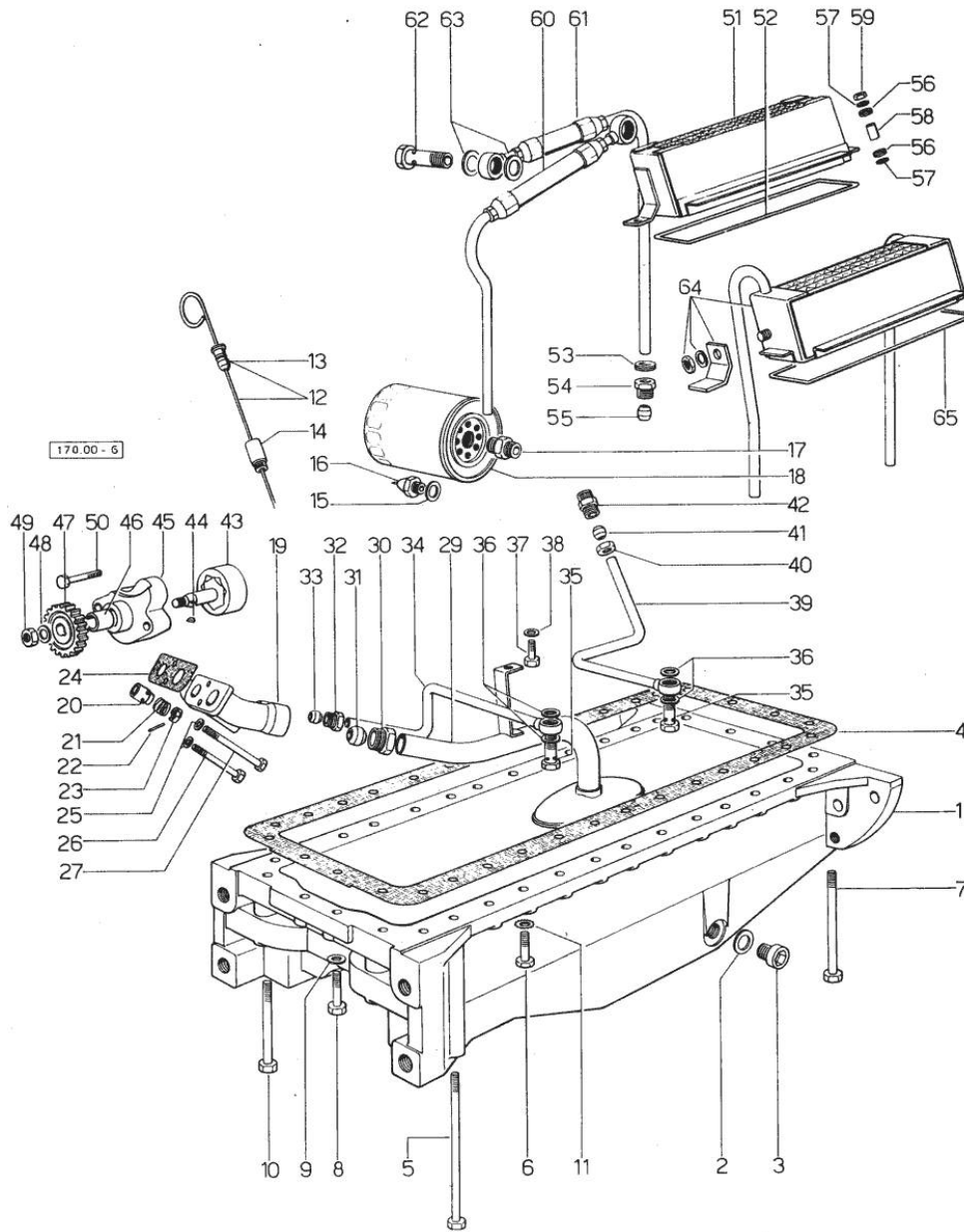

Fig.	P/n	QTY	Name
------	-----	-----	------

Notes:
[TIGER 100]

1	0.048.1510.0	1	oil sump
2	2.1560.054.0	1	gasket 21 x 26
3	2.3199.001.2	1	plug 1/2" gas
4	0.041.1512.0	1	gasket
5	2.0112.244.2	2	screw m 8 p.1.25 x 180
6	2.0112.215.2	22	screw m 8 p.1.25 x 40
7	2.0112.237.2	4	screw m 8 p.1.25x140
8	2.0112.217.2	2	screw m 8 p.1.25 x 45
9	2.1560.004.0	4	copper gasket 8.2 x 14
10	2.0112.231.1	2	screw m 8 p 1.25x110
11	2.1470.004.2	30	lock washer 8
12	0.041.1513.3	1	dipstick
13	0.034.1551.0	1	gasket
14	0.044.1555.0	1	spacer
15	2.1560.008.0	1	gasket 12.2 x 18
16	2.7099.040.0/10	1	pressure switch
17	2.3339.094.1/10	1	pipe fitting m 20 p.1.5-3/4 gas
18	0.041.1556.0	1	oil filter element
19	0.040.1530.0/10	1	tip
20	0.040.1550.0	1	small piston
21	2.4019.186.1	1	spring 15.8x53.5x1.8
22	2.1630.213.0	1	roll pin 3x32
23	0.040.1551.0	1	stop
24	0.037.1557.0/20	1	gasket
25	2.1480.014.1	1	washer 8
26	2.0112.225.2	1	screw m 8 p.1.25 x 80
27	2.0112.231.1	1	screw m 8 p 1.25x110
29	0.041.1531.3	1	tube
30	2.3319.030.1	1	pipe union
31	2.3359.008.0/10	1	nosepiece
32	2.3339.167.1	1	pipe fitting
33	2.3359.012.0	1	nosepiece 10x16.8
34	0.044.1542.2/10	1	tube
35	2.3330.007.1	2	pipe union
36	2.1560.018.0	4	gasket 22.2 x 29
37	2.0112.204.2	1	screw m 8 p.1.25x14
38	2.1310.004.2	1	flat washer 8.4x17
39	0.048.1543.2/20	1	tube
40	2.3339.096.1	1	pipe fitting
41	2.3359.012.0	1	nosepiece 10x16.8
42	2.3339.095.1/10	1	pipe fitting

<https://www.ebooklibonline.com>

Hello dear friend!

Thank you very much for reading.

Enter the link into your browser.

The full manual is available for immediate download.

<https://www.ebooklibonline.com>