

CRANKCASE

Fig.	P/n	QTY	Name
------	-----	-----	------

Notes:

[TIGER 80.4 2WD ->S10S704WXE45001] [TIGER 80.4 4WD ->S10S704WTE45001]

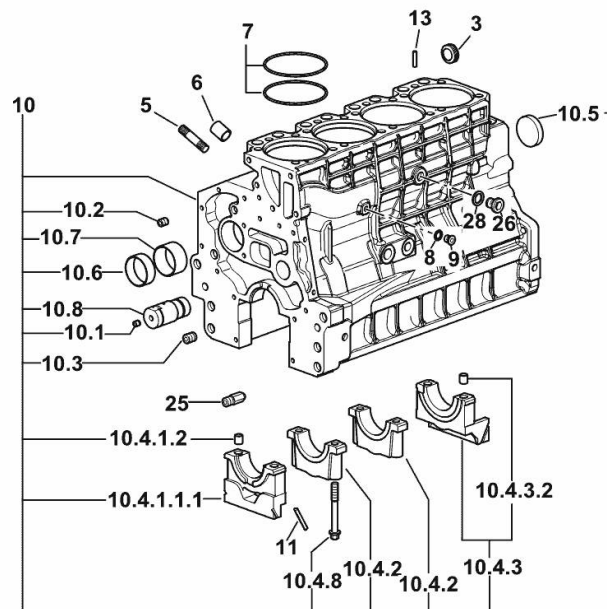

3	2.3199.312.2/20	1	plug m 35x1.5x9.5
5	2.0439.279.7	8	stud bolt m 8 p.1 x 25
6	2.1559.188.2	4	bush 11.4 x 14 x16
7	2.1539.259.0	8	special oil seal 107.62x2.62
8	2.1560.010.0	1	gasket 14.2 x 20
9	2.3199.292.0	1	plug 1/4" gas
10	0.014.9655.4/30	1	crankcase
10.1	2.3130.001.1	14	plug 1/8" gas
10.2	2.3130.002.1	4	plug 1/4" gas
10.3	2.3130.003.1	6	plug 3/8" gas
10.4.1.1.1	0.065.1112.7/10	1	support
10.4.1.2	2.1699.165.0	1	bush 12.3x15x16
10.4.2	0.065.1114.0/10	3	support
10.4.3	0.065.1116.3	1	support
10.4.3.2	2.1699.165.0	1	bush 12.3x15x16
10.4.8	0.065.1117.0	10	screw m 12 x 100
10.5	2.3179.012.0	1	plug 60
10.6	0.065.1140.0	4	special bushing 59X55X20
10.7	0.065.1141.0	1	special bushing 59X55X30
10.8	0.014.1340.0/10	1	pin mm 85
11	0.066.1152.0/10	4	gasket
13	2.1549.154.2	4	bush 4.8x5.8x16
25	0.013.4946.0/10	1	sprayer nozzle
26	2.3120.101.0	1	plug m 18 p.1.5
28	2.1560.014.0	1	washer 18.2 x 24

19_Q5011_00_0-A-001

MONOBLOC ENGINE-GEARBOX CONNECTING FLANGE

Fig.	P/n	QTY	Name
------	-----	-----	------

Notes:

[TIGER 80.4 2WD ->S10S704WXE45001] [TIGER 80.4 4WD ->S10S704WTE45001]

1	0.015.8814.0	1	flange
2	2.0112.511.2	8	screw m 14 p.2 x 30
3	2.0432.255.7	2	stud bolt m 12 p.1.75-1.25x25
4	2.1651.912.0	4	cylindrical plug 12x28
5	2.0512.404.7	2	screw

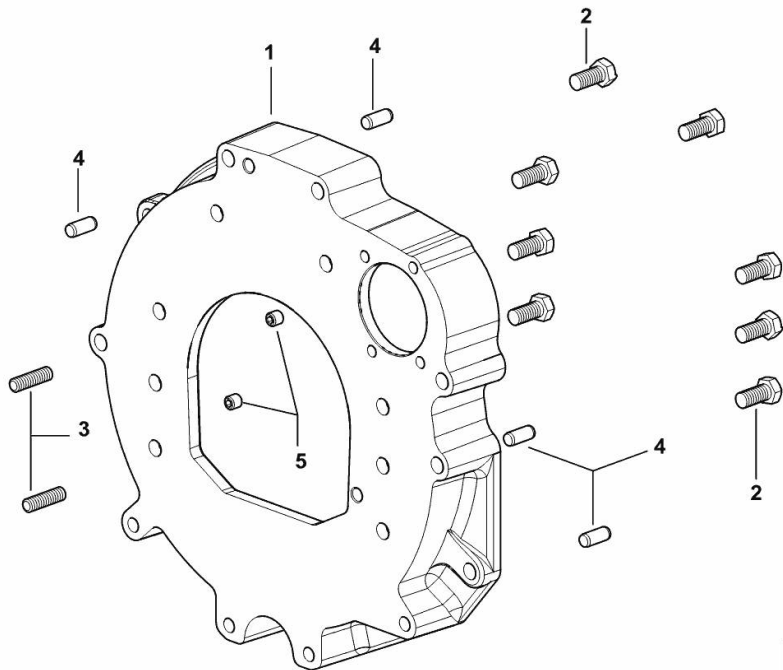

I9_38511_01_0-A-001

FITTING FOR ENGINE OIL PRESSURE SWITCH

Fig.	P/n	QTY	Name
------	-----	-----	------

Notes:

[TIGER 80.4 2WD ->S10S704WXE45001] [TIGER 80.4 4WD ->S10S704WTE45001]

100	2.3339.353.2/20	1	pipe fitting 12 p.1.5-18 p.1.5
101	2.1560.014.0	1	washer 18.2 x 24

19_37615_12_0-A-00

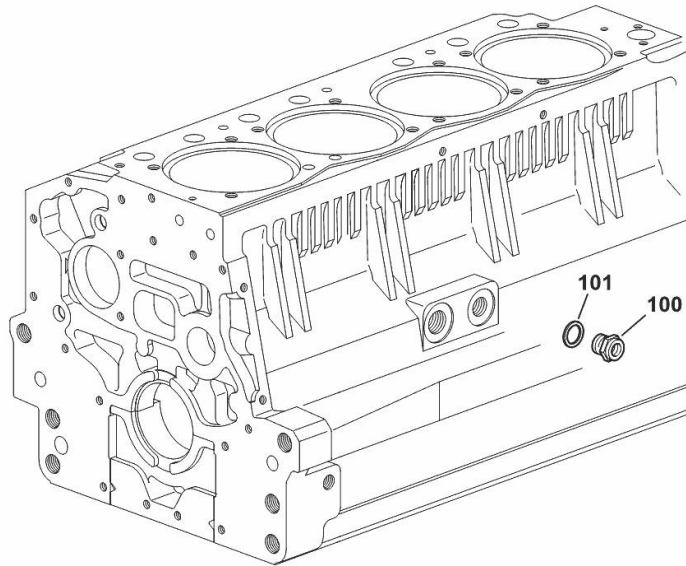

<https://www.ebooklibonline.com>

Hello dear friend!

Thank you very much for reading.

Enter the link into your browser.

The full manual is available for immediate download.

<https://www.ebooklibonline.com>

FITTING FOR ENGINE OIL PRESSURE SWITCH

Fig.	P/n	QTY	Name
------	-----	-----	------

Notes:

[TIGER 80.4 2WD ->S10S704WXE45001] [TIGER 80.4 4WD ->S10S704WTE45001]

1	2.3249.014.2	1	pipe fitting m 12 p.1.5
2	2.1560.008.0	3	gasket 12.2 x 18
3	2.3335.052.2	1	pipe union m 12 p.1.5

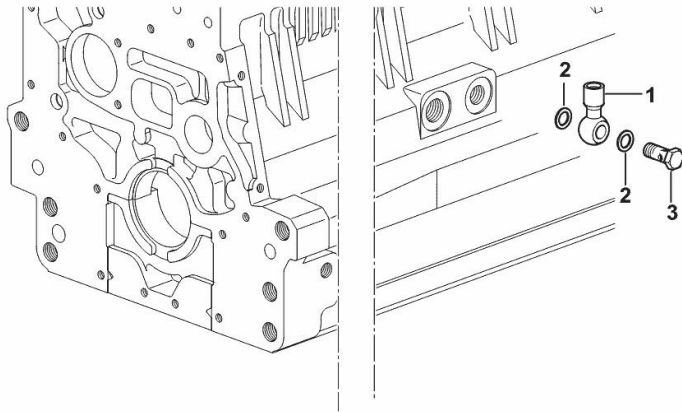

19_37615_07_0-A-001

SIDE PLUG FOR CYLINDER BLOCK

Fig.	P/n	QTY	Name
------	-----	-----	------

Notes:

[TIGER 80.4 2WD ->S10S704WXE45001] [TIGER 80.4 4WD ->S10S704WTE45001]

22	2.1560.017.0	1	gasket 22.2 x 27
23	2.3120.002.4	1	plug m 22 x 1.5

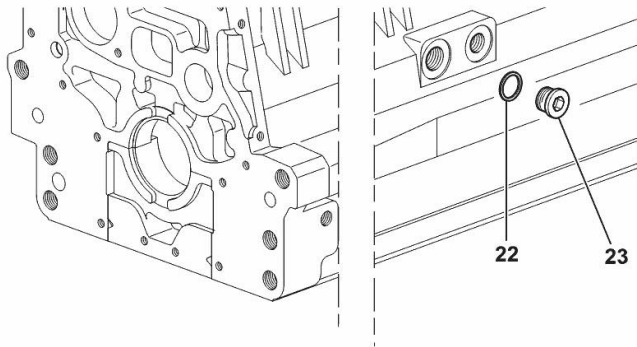

I9_33211_07_0-A-001

LOWER PLUG FOR CYLINDER BLOCKS

Fig.	P/n	QTY	Name
------	-----	-----	------

Notes:

[TIGER 80.4 2WD ->S10S704WXE45001] [TIGER 80.4 4WD ->S10S704WTE45001]

1	2.3130.003.1	2	plug 3/8" gas
---	--------------	---	---------------

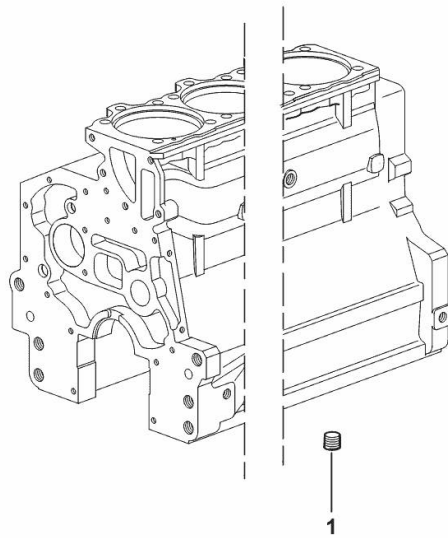

19_37511_06_0-A-001

CRANKSHAFT

Fig.	P/n	QTY	Name
------	-----	-----	------

Notes:

[TIGER 80.4 2WD ->S10S704WXE45001] 45186 <- [TIGER 80.4 4WD ->S10S704WTE45001] 45186 <-

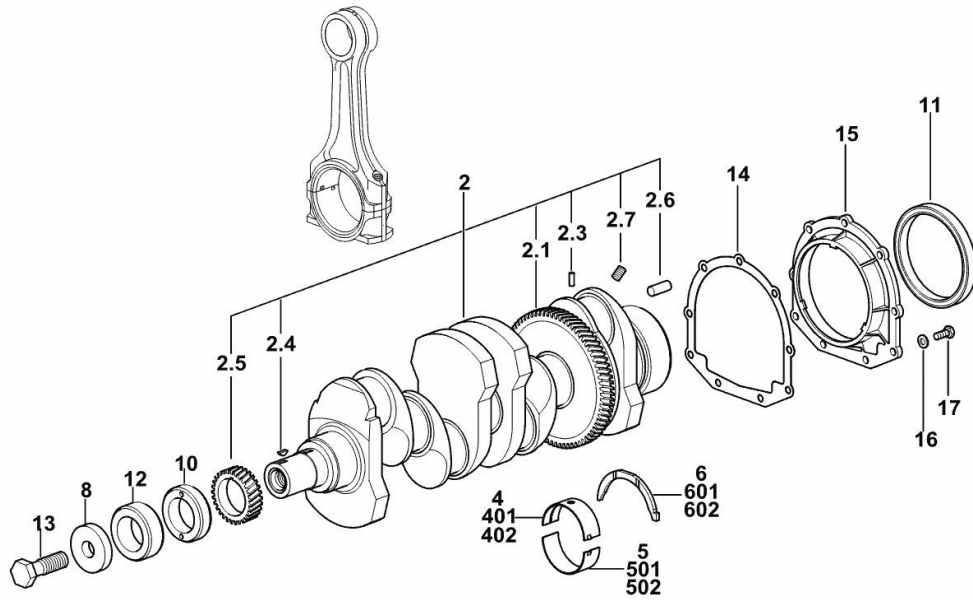

2	0.086.1210.3/40	1	crankshaft
2.1	0.065.1211.0/10	1	crown wheel
2.3	2.1630.608.0	1	pin 6x16
2.4	2.1720.006.0	1	key 4x6.5
2.5	0.065.1323.0/30	1	gear Z = 29
2.6	2.1651.915.0	1	pin 12x35
2.7	2.3130.001.1	4	plug 1/8" gas
4	0.065.1215.0/10	5	main half bushing STANDARD
5	0.065.1216.0/10	5	main half bushing STANDARD
6	0.065.1218.0	4	shim STANDARD
8	2.1599.524.7	1	washer 21x60x12
10	0.085.1248.0/20	1	hub
11	2.1529.073.0	1	special oil seal 110x130x13
12	0.014.7054.0	1	spacer
13	2.0399.144.7/10	1	screw m 20 p.1.5x51
14	0.065.1254.0/20	1	gasket
15	0.007.1711.0/10	1	cover
16	2.1475.002.2	9	conical washer 8
17	2.0112.207.2	9	screw m 8 p 1.25 x 20
401	0.065.1215.7	1	main half bushing - mm 0.25
402	0.065.1215.8	1	main half bushing - mm 0.50
501	0.065.1216.7	1	main half bushing - mm 0.25
502	0.065.1216.8	1	main half bushing - mm 0.50
601	0.065.1218.7	1	shim + mm 0.10
602	0.065.1218.8	1	shim + mm 0.15

19_M7612_00_0-A-001

CRANKSHAFT

Fig.	P/n	QTY	Name
------	-----	-----	------

Notes:

[TIGER 80.4 2WD ->S10S704WXE45001] [TIGER 80.4 4WD ->S10S704WTE45001]

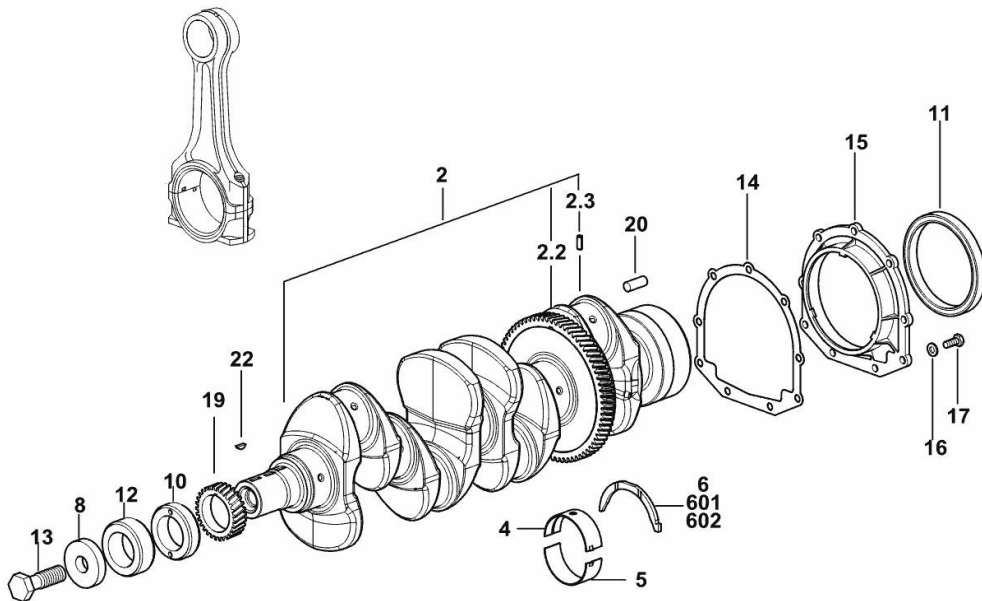

2	0.021.8246.3	1	crankshaft
2.2	0.065.1211.0/10	1	crown wheel
2.3	2.1630.608.0	1	pin 6x16
4	0.019.5455.0	5	main half bushing STANDARD
5	0.019.5456.0	5	main half bushing STANDARD
6	0.065.1218.0	4	shim STANDARD
8	2.1599.524.7	1	washer 21x60x12
10	0.085.1248.0/20	1	hub
11	2.1529.073.0	1	special oil seal 110x130x13
12	0.014.7054.0	1	spacer
13	2.0399.144.7/10	1	screw m 20 p.1.5x51
14	0.065.1254.0/20	1	gasket
15	0.007.1711.0/10	1	cover
16	2.1475.002.2	9	conical washer 8
17	2.0112.207.2	9	screw m 8 p 1.25 x 20
19	0.065.1323.0/30	1	gear Z = 29
20	2.1651.915.0	1	pin 12x35
22	2.1720.006.0	1	key 4x6.5
601	0.065.1218.7		shim + mm 0.10
602	0.065.1218.8		shim + mm 0.15

19_M7612_00_0-A-002

CRANKSHAFT PULLEY

Fig.	P/n	QTY	Name
------	-----	-----	------

Notes:

[TIGER 80.4 2WD ->S10S704WXE45001] [TIGER 80.4 4WD ->S10S704WTE45001]

3	0.007.1457.0/30	1	pulley
5	0.085.1248.0/20	1	hub
6	2.0399.144.7/10	1	screw m 20 p.1.5x51
8	2.1720.006.0	1	key 4x6.5

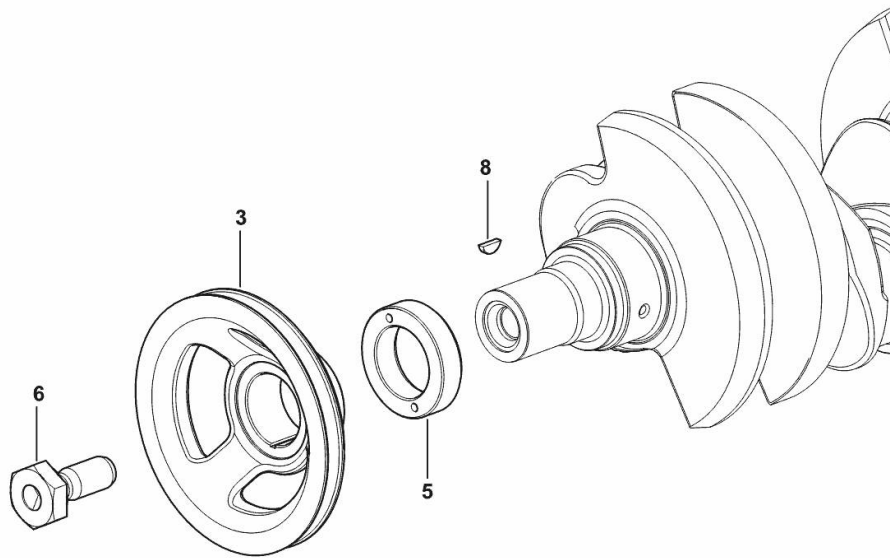

19_33312_02_0-A-001

BELT

Fig.	P/n	QTY	Name
------	-----	-----	------

Notes:

[TIGER 80.4 2WD ->S10S704WXE45001] [TIGER 80.4 4WD ->S10S704WTE45001]

3	2.4119.198.0	1	vee belt AV 10.7x1240 mm
---	--------------	---	--------------------------

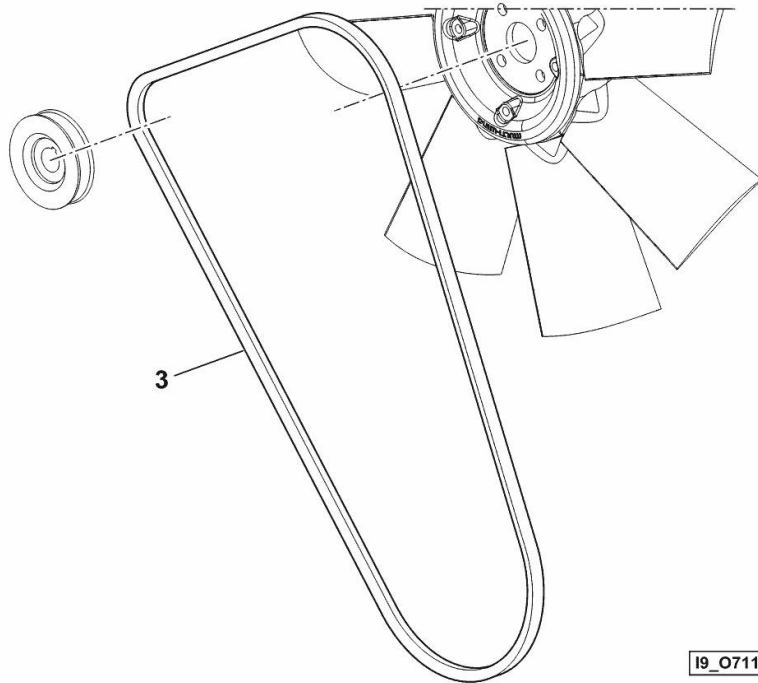

19_O7119_11_0-B-001

ENGINE FLYWHEEL

Fig.	P/n	QTY	Name
------	-----	-----	------

Notes:

[TIGER 80.4 2WD ->S10S704WXE45001] [TIGER 80.4 4WD ->S10S704WTE45001]

1	0.017.7896.3	1	flywheel
1.2	0.065.1242.0	1	crown wheel Z = 123
2	2.0119.174.0/10	6	screw m 12 p.1.25x45
3	2.2041.008.9	1	ball bearing 20x47x14

19_Q5612_01_0-A-001

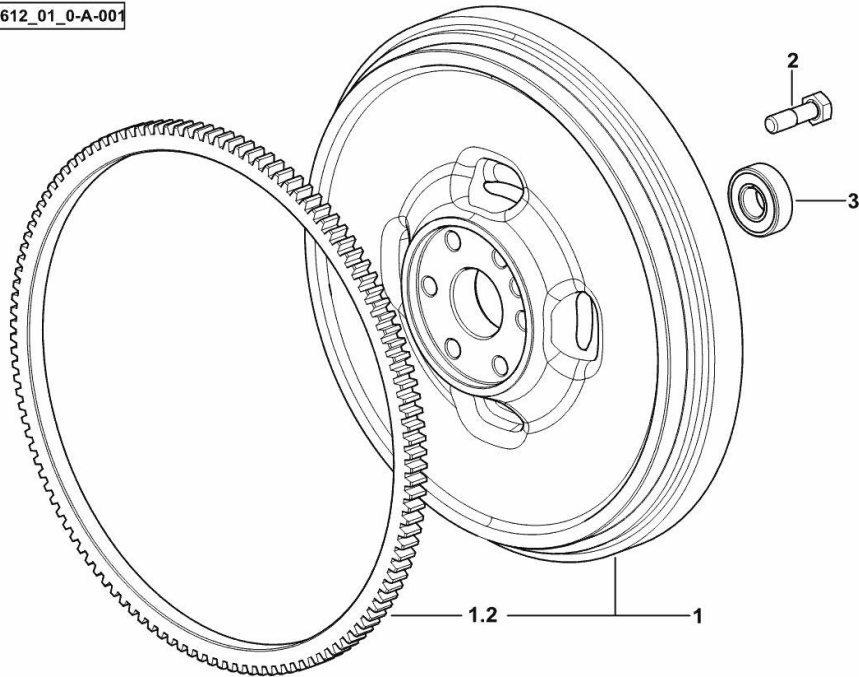

COUNTERWEIGHTS

Fig.	P/n	QTY	Name
------	-----	-----	------

Notes:

[TIGER 80.4 2WD ->S10S704WXE45001] [TIGER 80.4 4WD ->S10S704WTE45001]

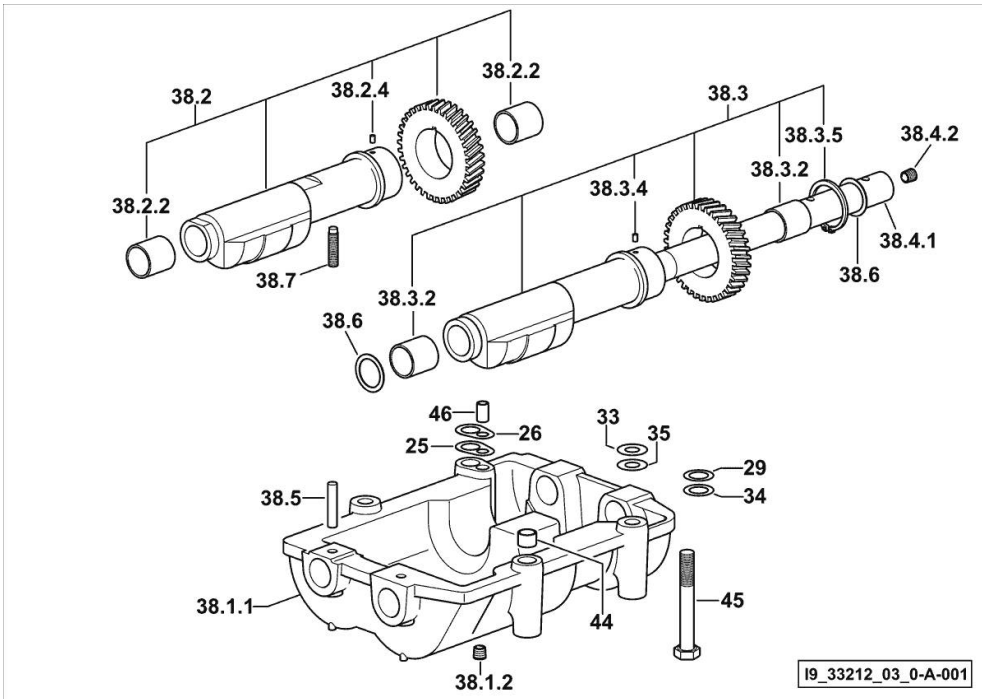

25	2.1589.139.0	1	shoulder ring mm 0.3
26	2.1589.140.0	3	shoulder ring mm 0.1
29	2.1579.628.0	3	spacer 16.5x26x0.1
33	2.1579.629.0	6	spacer 12.5x26x0.1
34	2.1589.048.0	1	shoulder ring 16.5x26x0.3
35	2.1589.049.0	1	shoulder ring 12.5x26x0.3
38.1.1	0.086.1231.0/10	1	box
38.1.2	2.3130.001.1	4	plug 1/8" gas
38.2	0.086.1233.3/30	1	mass sx/lh/li
38.2.2	2.1559.115.0	2	special bushing 26x30x30
38.2.4	2.1651.302.0	1	roll pin 4x6
38.3	0.065.1233.3/30	1	mass dx/rh/re
38.3.2	2.1559.115.0	2	special bushing 26x30x30
38.3.4	2.1651.302.0	1	roll pin 4x6
38.3.5	2.1410.018.1	1	circlip 45
38.4.1	0.065.1234.0/10	1	shaft
38.4.2	2.3130.001.1	1	plug 1/8" gas
38.5	2.1631.717.0	2	roll pin 8 x 40
38.6	2.1589.185.0	4	shoulder ring 26.1x34x1
38.7	2.0522.212.7	1	screw m 8 p.1.25 x 30
44	2.1579.626.0	2	spacer 13.2x16x11
45	2.0139.028.2	4	screw m 12
46	2.1699.191.0	1	bush 7x10x16

CYLINDER - PISTON - CONNECTING ROD

Fig.	P/n	QTY	Name
------	-----	-----	------

Notes:

[TIGER 80.4 2WD ->S10S704WXE45001] [TIGER 80.4 4WD ->S10S704WTE45001]

1	0.082.0065.A	4	cyl. piston assembly "A" - CLASS A
1	0.082.0065.B	4	cyl. piston assembly "B" - CLASS B
1.2	0.A12.2675.0	1	engine cylinder "A" - CLASS A
1.2	0.B12.2675.0	1	engine cylinder "B" - CLASS B
1.3	0.082.0060.A	1	complete piston "A" - CLASS A
1.3	0.082.0060.B	1	complete piston "B" - CLASS B
1.3.1	0.086.0052.6/10	1	piston ring set
1.3.2	2.1411.014.1	1	circlip 35
1.3.3	0.078.1236.0	1	piston pin Ø 18 / Ø 35 / L = mm 86
2	0.014.5175.3	4	engine connecting rod (...) <-
2	0.019.2226.3/10	4	engine connecting rod -> (...)
2.1	2.1559.255.0	1	special bushing 34.60x39.130x34.65 (...) <-
2.1	2.1559.532.0	1	special bushing 34.60x39.130x36.65 -> (...)
2.2	2.0399.213.0	2	screw m 12 p.1.25x61.5 (...) <-
2.2	2.0399.365.0	2	screw m 10 p.1.25x61.5 -> (...)
3	0.065.1225.0	8	con.rod half bushing STANDARD - A = 28.75 -> 29.00 (...) <-
3	0.065.1225.7	8	con.rod half bushing - mm 0.25 (...) <-
3	0.065.1225.8	8	con.rod half bushing - mm 0.50 (...) <-
4	0.019.5453.0	4	con.rod half bushing STANDARD - A = 29.85 -> 30.10 -> (...)
5	0.019.5454.0	4	con.rod half bushing STANDARD - A = 29.85 -> 30.10 -> (...)

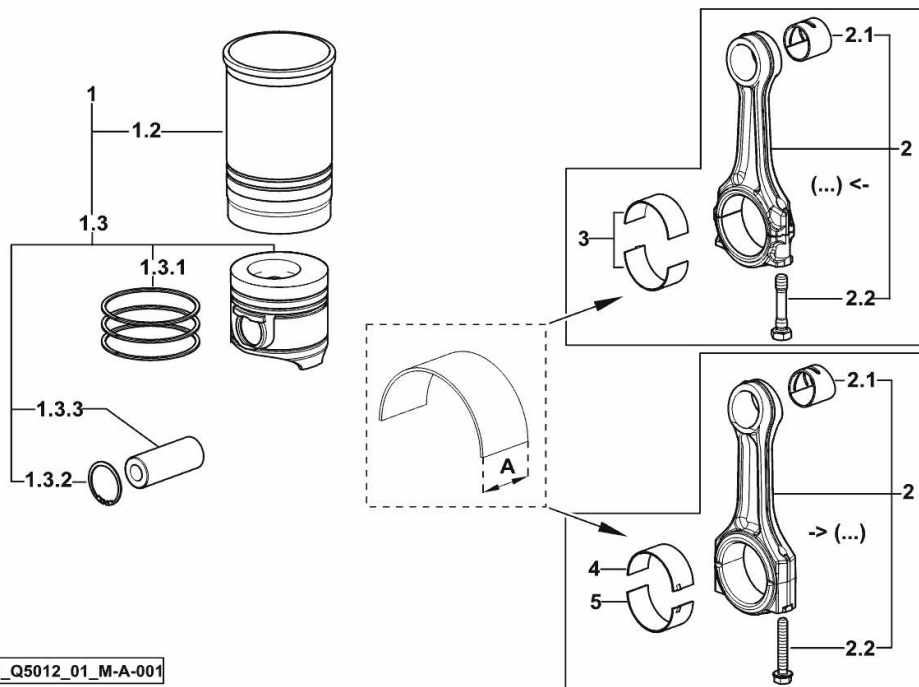



Suggest:

For more complete manuals. Please go to the home page.

<https://www.ebooklibonline.com>

If the above button click is invalid. Please download this document first, and then click the above link to download the complete manual.

Thank you so much for reading

CAMSHAFT

Fig.	P/n	QTY	Name
------	-----	-----	------

Notes:

[TIGER 80.4 2WD ->S10S704WXE45001] [TIGER 80.4 4WD ->S10S704WTE45001]

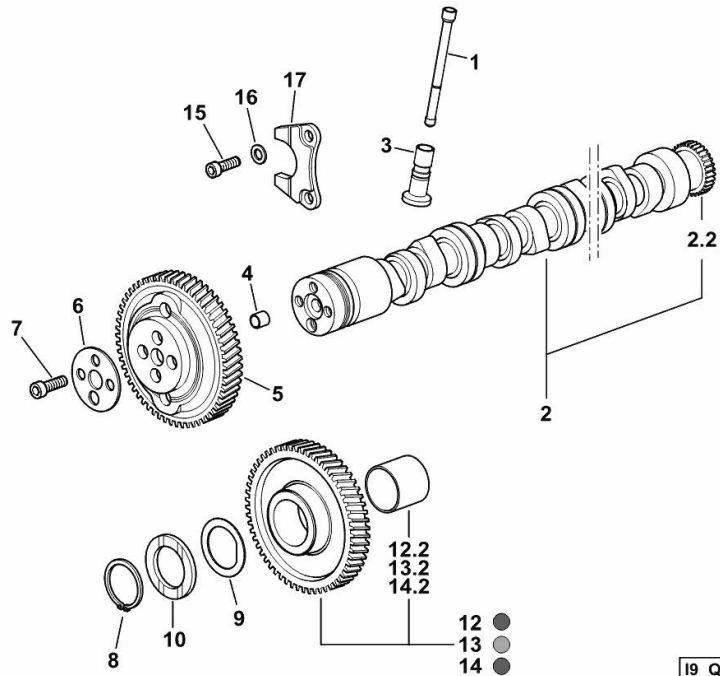

1	0.065.1331.2	8	rod
2	0.013.1463.3/20	1	camshaft
2.2	0.065.1324.0/10	1	gear Z = 32
3	0.065.1330.0	8	tappets
4	2.1559.398.0	1	bushing 10.5x13x12
5	0.013.5017.0	1	gear z=58
6	0.065.1350.0	1	small disc
7	2.0132.207.2	4	screw m 10 p.1 x 25
8	2.1410.016.1	1	circlip 40
9	0.065.1352.0	1	shim
10	0.018.2233.0	2	shoulder ring
12	0.007.1177.3/20	0.5	gear z = 57 - WITH RED IDENTIFICATION STAMP
12.2	2.1559.185.0/10	1	bushing
13	0.007.1178.3/20	0.5	gear z = 57 - WITH YELLOW IDENTIFICATION STAMP
13.2	2.1559.185.0/10	1	bushing
14	0.007.1179.3/20		gear z = 57 - WITH GREEN IDENTIFICATION STAMP
14.2	2.1559.185.0/10	1	bushing
15	2.0312.205.2	2	screw
16	2.1480.014.1	2	washer 8
17	0.065.1353.0	1	small plate

TIMING CASE

Fig.	P/n	QTY	Name
------	-----	-----	------

Notes:

[TIGER 80.4 2WD ->S10S704WXE45001] [TIGER 80.4 4WD ->S10S704WTE45001]

4	2.1890.003.2	2	expansion plug 6
15	2.0432.003.7	2	stud bolt m 8 p.1.25 / p.1 x 20
16	2.0312.214.2	7	screw m 8 p.1.25 x 40
17	2.1480.014.1	15	washer 8
18	0.013.4981.0	1	guard
19	0.065.1150.0/30	1	gasket
22	2.0312.208.2	8	screw m 8 p.1.25 x 25
23	2.1529.167.0	1	oil seal

19_Q5011_00_0-B-001

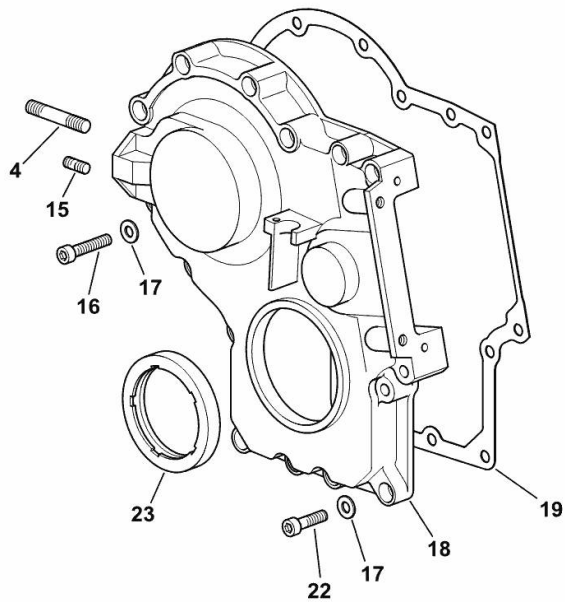

<https://www.ebooklibonline.com>

Hello dear friend!

Thank you very much for reading.

Enter the link into your browser.

The full manual is available for immediate download.

<https://www.ebooklibonline.com>