

**CRANKCASE**

Fig.	P/n	QTY	Name
------	-----	-----	------

**Notes:**

[TIGER 80.4 E 2WD ->S10S714WX1E40001] [TIGER 80.4 E 4WD ->S10S714WT1E40001]

2	2.1539.047.0	1	special oil seal 26.7x1.78
3	2.3199.405.2	1	plug m 28 p.1.5
6	2.1559.188.2	4	bush 11.4 x 14 x16
7	2.1539.259.0	8	special oil seal 107.62x2.62
8	2.1560.010.0	1	gasket 14.2 x 20
9	2.3199.292.0	1	plug 1/4" gas
10	0.082.1110.6/20	1	crankcase
10.1	2.3130.001.1	11	plug 1/8" gas
10.2	2.3130.002.1	2	plug 1/4" gas
10.3	2.3130.003.1	5	plug 3/8" gas
10.4.1.1	0.065.1112.3	1	support
10.4.1.1.2	2.1699.165.0	1	bush 12.3x15x16
10.4.1.2	0.065.1114.0/10	3	support
10.4.1.3	0.065.1116.3	1	support
10.4.1.3.2	2.1699.165.0	1	bush 12.3x15x16
10.4.1.8	0.065.1117.0	10	screw m 12 x 100
10.4.2	0.012.0829.0	4	special bushing 59X55X20
10.4.3	0.012.0830.0	1	special bushing 59X55X30
10.4.4	0.014.1340.0/10	1	pin mm 85
10.8	2.3179.012.0	1	plug 60
10.9	2.1324.011.0	1	plug
11	0.066.1152.0/10	4	gasket
13	2.1549.154.2	4	bush 4.8x5.8x16
15	2.0432.003.7	14	stud bolt m 8 p.1.25 / p.1 x 20
26	2.3120.101.0	1	plug m 18 p.1.5
28	2.1560.014.0	1	washer 18.2 x 24
29	2.3171.010.4	1	plug 25
30	0.013.4946.0/10	1	sprayer nozzle

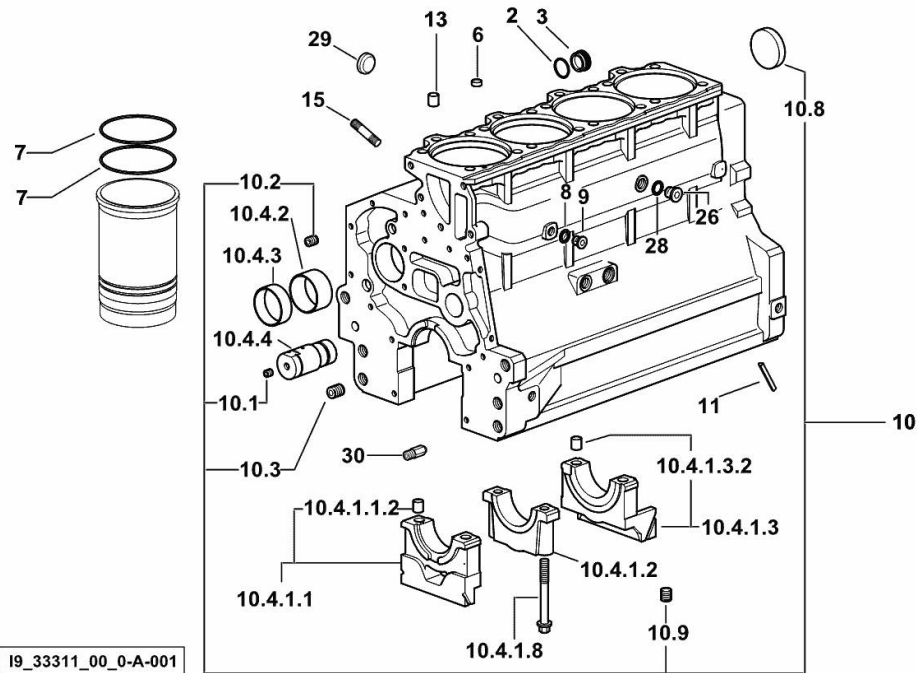

**MONOBLOC ENGINE-GEARBOX CONNECTING FLANGE**

Fig.	P/n	QTY	Name
------	-----	-----	------

**Notes:**  
 [TIGER 80.4 E 2WD ->S10S714WX1E40001] [TIGER 80.4 E 4WD ->S10S714WT1E40001]

1	0.015.8814.0	1	flange
2	2.0112.511.2	8	screw m 14 p.2 x 30
3	2.0432.255.7	2	stud bolt m 12 p.1.75-1.25x25
4	2.1651.912.0	4	cylindrical plug 12x28
5	2.0512.404.7	2	screw

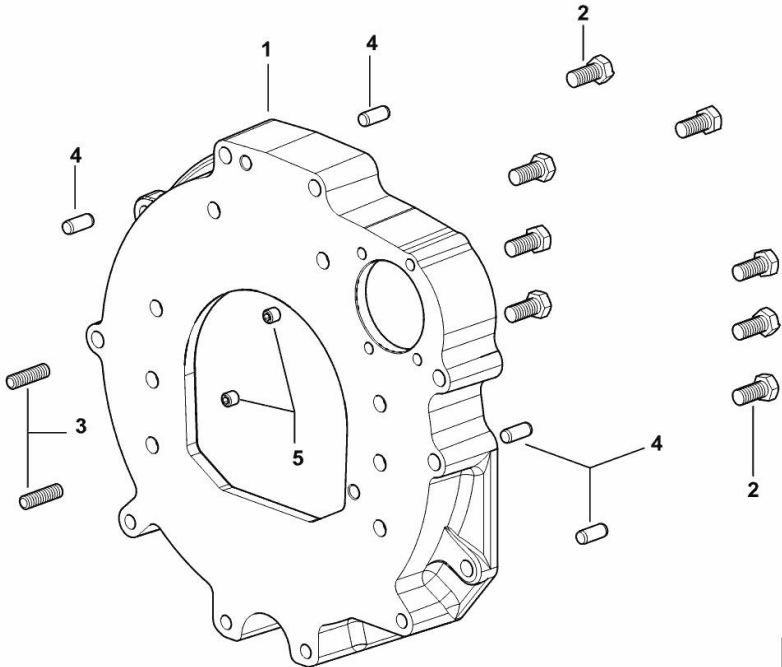

FITTING FOR ENGINE OIL PRESSURE SWITCH

Fig.	P/n	QTY	Name
------	-----	-----	------

Notes:  
 [TIGER 80.4 E 2WD ->S10S714WX1E40001] [TIGER 80.4 E 4WD ->S10S714WT1E40001]

1	2.3249.014.2	1	pipe fitting m 12 p.1.5
2	2.1560.008.0	3	gasket 12.2 x 18
3	2.3335.052.2	1	pipe union m 12 p.1.5

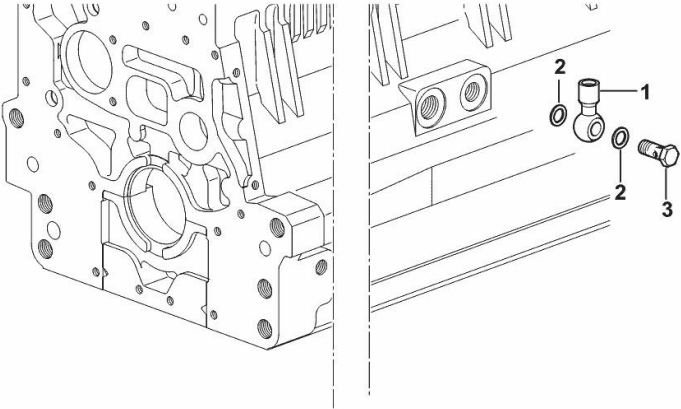

19\_37615\_07\_0-A-001

**<https://www.ebooklibonline.com>**

Hello dear friend!

Thank you very much for reading.

Enter the link into your browser.

The full manual is available for immediate download.

**<https://www.ebooklibonline.com>**

**FITTING FOR ENGINE OIL PRESSURE SWITCH**

Fig.	P/n	QTY	Name
------	-----	-----	------

**Notes:**

[TIGER 80.4 E 2WD ->S10S714WX1E40001] [TIGER 80.4 E 4WD ->S10S714WT1E40001]

100	2.3339.353.2/20	1	pipe fitting 12 p.1.5-18 p.1.5
101	2.1560.014.0	1	washer 18.2 x 24

19\_37615\_12\_0-A-00

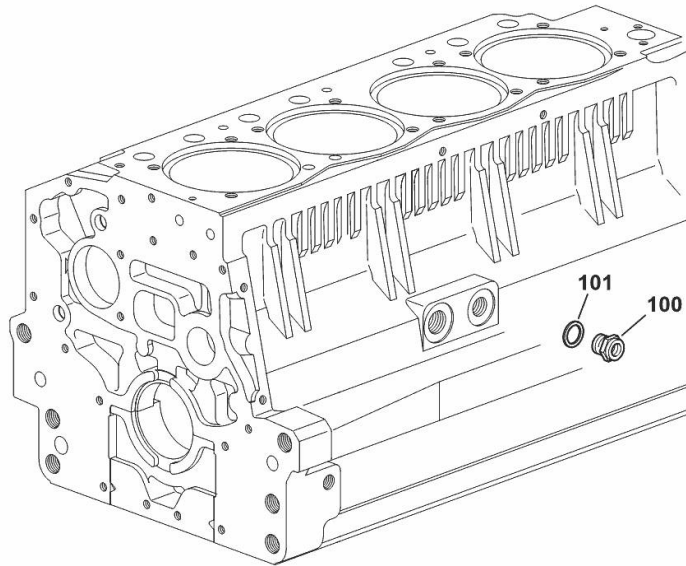

**SIDE PLUG FOR CYLINDER BLOCK**

Fig.	P/n	QTY	Name
------	-----	-----	------

**Notes:**

[TIGER 80.4 E 2WD ->S10S714WX1E40001] [TIGER 80.4 E 4WD ->S10S714WT1E40001]

22	2.1560.017.0	1	gasket 22.2 x 27
23	2.3120.002.4	1	plug m 22 x 1.5

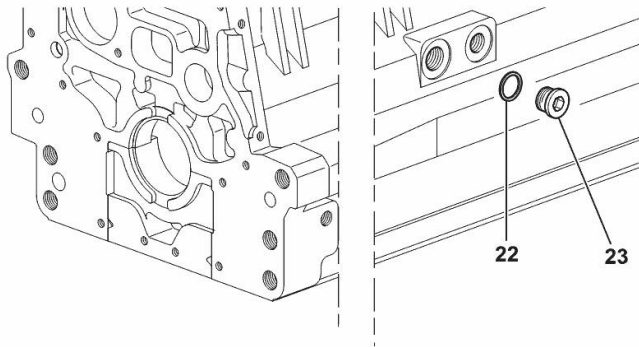

I9\_33211\_07\_0-A-001

**LOWER PLUG FOR CYLINDER BLOCKS**

Fig.	P/n	QTY	Name
------	-----	-----	------

**Notes:**  
 [TIGER 80.4 E 2WD ->S10S714WX1E40001] [TIGER 80.4 E 4WD ->S10S714WT1E40001]

1	2.3130.003.1	2	plug 3/8" gas
---	--------------	---	---------------

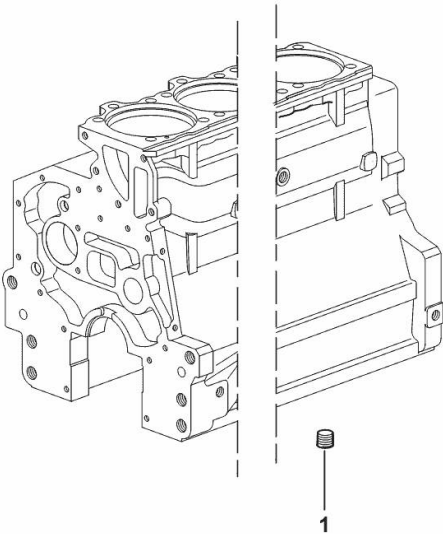

19\_37511\_06\_0-A-001

**CRANKSHAFT**

Fig.	P/n	QTY	Name
------	-----	-----	------

**Notes:**

[TIGER 80.4 E 2WD ->S10S714WX1E40001] 40361 <- [TIGER 80.4 E 4WD ->S10S714WT1E40001] 40361 <-

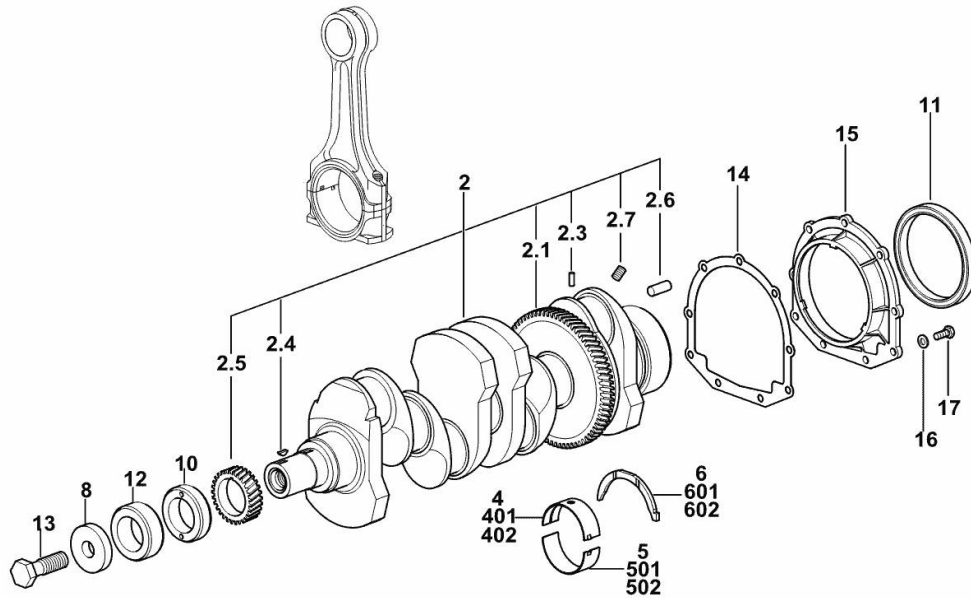

2	0.086.1210.3/40	1	crankshaft
2.1	0.065.1211.0/10	1	crown wheel
2.3	2.1630.608.0	1	pin 6x16
2.4	2.1720.006.0	1	key 4x6.5
2.5	0.065.1323.0/30	1	gear Z = 29
2.6	2.1651.915.0	1	pin 12x35
2.7	2.3130.001.1	4	plug 1/8" gas
4	0.065.1215.0/10	5	main half bushing STANDARD
5	0.065.1216.0/10	5	main half bushing STANDARD
6	0.065.1218.0	4	shim STANDARD
8	2.1599.524.7	1	washer 21x60x12
10	0.085.1248.0/20	1	hub
11	2.1529.073.0	1	special oil seal 110x130x13
12	0.014.7054.0	1	spacer
13	2.0399.144.7/10	1	screw m 20 p.1.5x51
14	0.065.1254.0/20	1	gasket
15	0.007.1711.0/10	1	cover
16	2.1475.002.2	9	conical washer 8
17	2.0112.207.2	9	screw m 8 p 1.25 x 20
401	0.065.1215.7	1	main half bushing - mm 0.25
402	0.065.1215.8	1	main half bushing - mm 0.50
501	0.065.1216.7	1	main half bushing - mm 0.25
502	0.065.1216.8	1	main half bushing - mm 0.50
601	0.065.1218.7	1	shim + mm 0.10
602	0.065.1218.8	1	shim + mm 0.15

19\_M7612\_00\_0-A-001

**CRANKSHAFT**

Fig.	P/n	QTY	Name
2	0.021.8246.3	1	crankshaft
2.2	0.065.1211.0/10	1	crown wheel
2.3	2.1630.608.0	1	pin 6x16
4	0.019.5455.0	5	main half bushing STANDARD
5	0.019.5456.0	5	main half bushing STANDARD
6	0.065.1218.0	4	shim STANDARD
8	2.1599.524.7	1	washer 21x60x12
10	0.085.1248.0/20	1	hub
11	2.1529.073.0	1	special oil seal 110x130x13
12	0.014.7054.0	1	spacer
13	2.0399.144.7/10	1	screw m 20 p.1.5x51
14	0.065.1254.0/20	1	gasket
15	0.007.1711.0/10	1	cover
16	2.1475.002.2	9	conical washer 8
17	2.0112.207.2	9	screw m 8 p 1.25 x 20
19	0.065.1323.0/30	1	gear Z = 29
20	2.1651.915.0	1	pin 12x35
22	2.1720.006.0	1	key 4x6.5
601	0.065.1218.7		shim + mm 0.10
602	0.065.1218.8		shim + mm 0.15

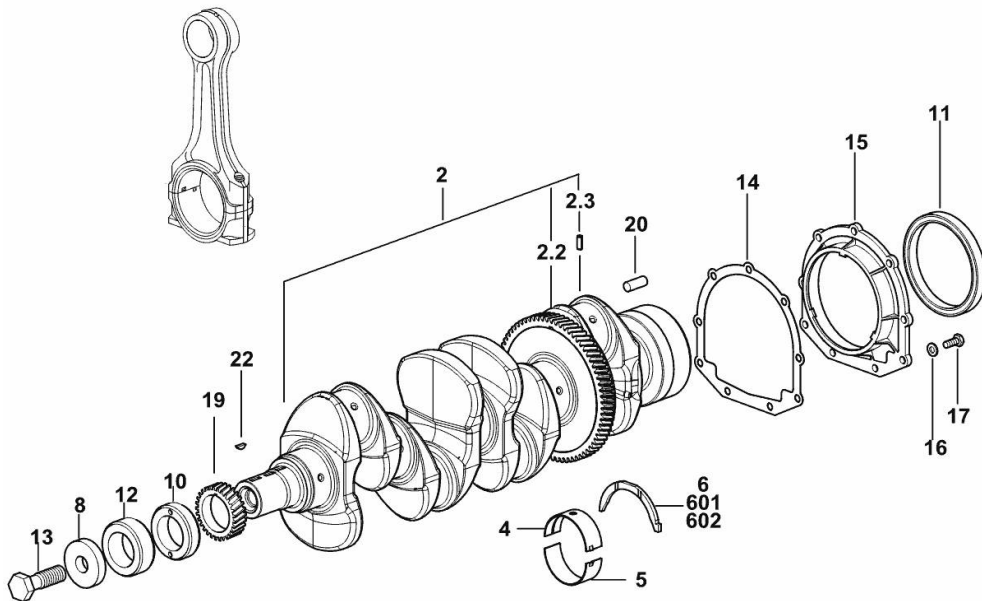

19\_M7612\_00\_0-A-002

**CRANKSHAFT**

Fig.	P/n	QTY	Name
------	-----	-----	------

**Notes:**

[TIGER 80.4 E 2WD ->S10S714WX1E40001] -> 40345 - 40571 <- [TIGER 80.4 E 4WD ->S10S714WT1E40001] -> 40345 - 40571 <-

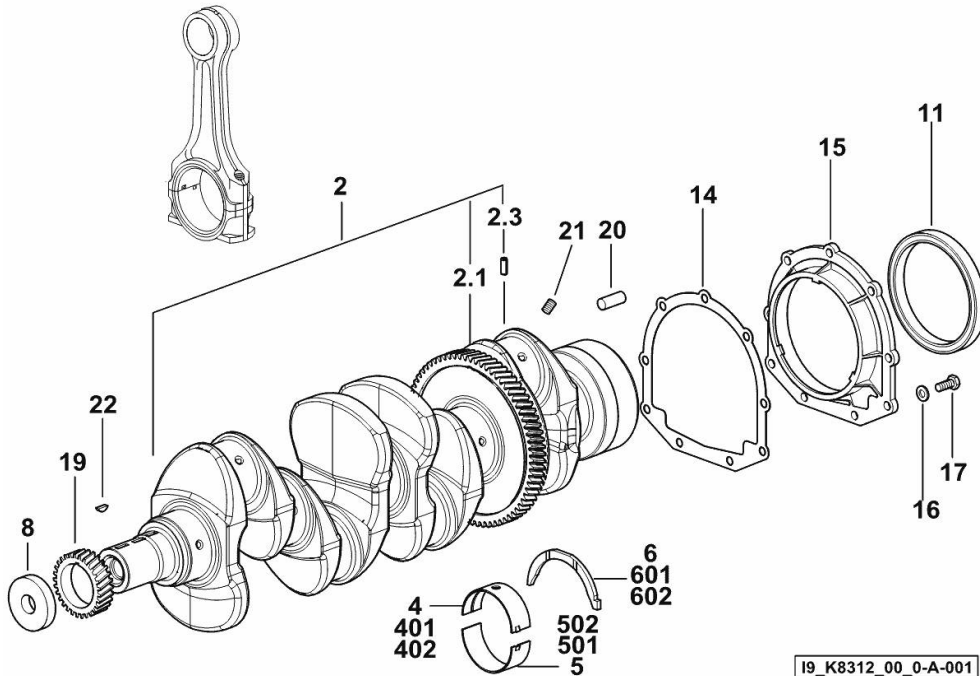

2	0.015.5817.3/20	1	crankshaft
2.1	0.065.1211.0/10	1	crown wheel
2.3	2.1630.608.0	1	pin 6x16
4	0.014.5262.0	5	main half bushing STANDARD
5	0.014.5263.0	5	main half bushing STANDARD
6	0.065.1218.0	4	shim STANDARD
8	2.1599.524.7	1	washer 21x60x12
11	2.1529.073.0	1	special oil seal 110x130x13
14	0.065.1254.0/20	1	gasket
15	0.007.1711.0/10	1	cover
16	2.1475.002.2	9	conical washer 8
17	2.0112.207.2	9	screw m 8 p 1.25 x 20
19	0.065.1323.0/30	1	gear Z = 29
20	2.1651.915.0	1	pin 12x35
21	2.3130.001.1	4	plug 1/8" gas
22	2.1720.006.0	1	key 4x6.5
401	0.065.1215.7	1	main half bushing - mm 0.25
402	0.065.1215.8	1	main half bushing - mm 0.50
501	0.065.1216.7	1	main half bushing - mm 0.25
502	0.065.1216.8	1	main half bushing - mm 0.50
601	0.065.1218.7	1	shim + mm 0.10
602	0.065.1218.8	1	shim + mm 0.15

19\_K8312\_00\_0-A-001

**CRANKSHAFT**

Fig.	P/n	QTY	Name
------	-----	-----	------

**Notes:**

[TIGER 80.4 E 2WD ->S10S714WX1E40001] -> 40572 [TIGER 80.4 E 4WD ->S10S714WT1E40001] -> 40572

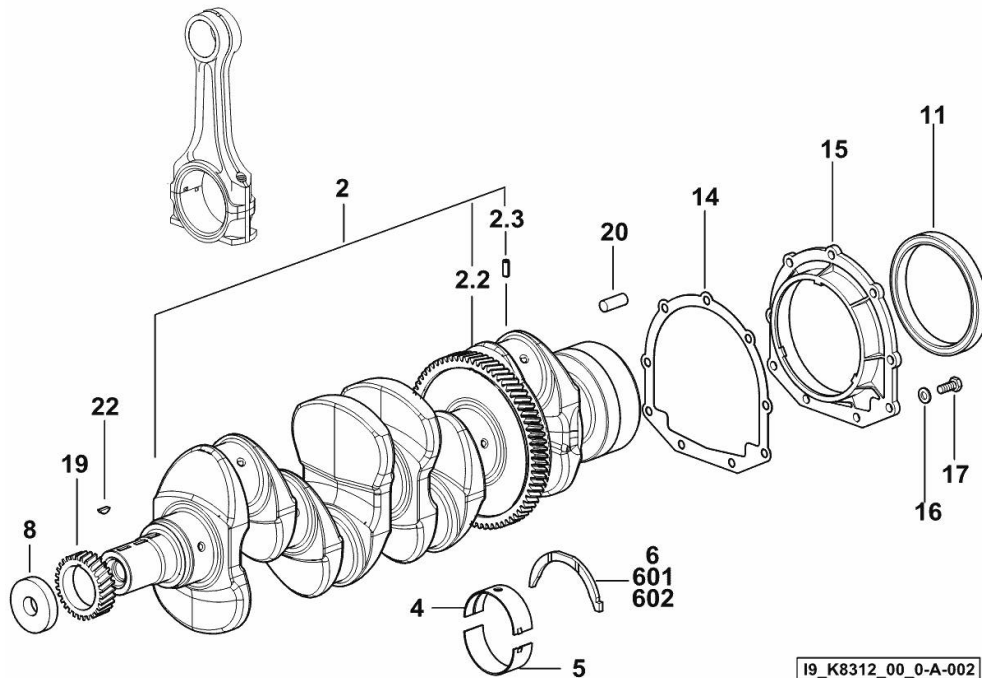

19\_K8312\_00\_0-A-002

2	0.021.8246.3	1	crankshaft
2.2	0.065.1211.0/10	1	crown wheel
2.3	2.1630.608.0	1	pin 6x16
4	0.019.5455.0	5	main half bushing STANDARD
5	0.019.5456.0	5	main half bushing STANDARD
6	0.065.1218.0	4	shim STANDARD
8	2.1599.524.7	1	washer 21x60x12
11	2.1529.073.0	1	special oil seal 110x130x13
14	0.065.1254.0/20	1	gasket
15	0.007.1711.0/10	1	cover
16	2.1475.002.2	9	conical washer 8
17	2.0112.207.2	9	screw m 8 p 1.25 x 20
19	0.065.1323.0/30	1	gear Z = 29
20	2.1651.915.0	1	pin 12x35
22	2.1720.006.0	1	key 4x6.5
601	0.065.1218.7	1	shim + mm 0.10
602	0.065.1218.8	1	shim + mm 0.15

**ENGINE FLYWHEEL**

Fig.	P/n	QTY	Name
------	-----	-----	------

**Notes:**

[TIGER 80.4 E 2WD ->S10S714WX1E40001] [TIGER 80.4 E 4WD ->S10S714WT1E40001]

1	0.017.7896.3	1	flywheel
1.2	0.065.1242.0	1	crown wheel Z = 123
2	2.0119.174.0/10	6	screw m 12 p.1.25x45
3	2.2041.008.9	1	ball bearing 20x47x14

19\_Q5612\_01\_0-A-001

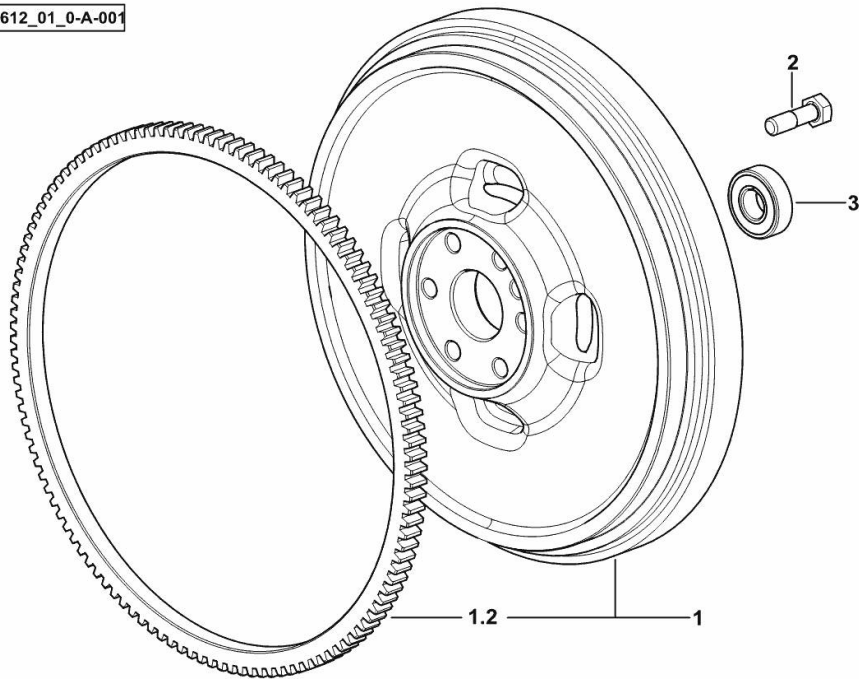

**CRANKSHAFT PULLEY**

Fig.	P/n	QTY	Name
------	-----	-----	------

**Notes:**

[TIGER 80.4 E 2WD ->S10S714WX1E40001] [TIGER 80.4 E 4WD ->S10S714WT1E40001]

3	0.007.1457.0/30	1	pulley
5	0.085.1248.0/20	1	hub
6	2.0399.144.7/10	1	screw m 20 p.1.5x51
8	2.1720.006.0	1	key 4x6.5

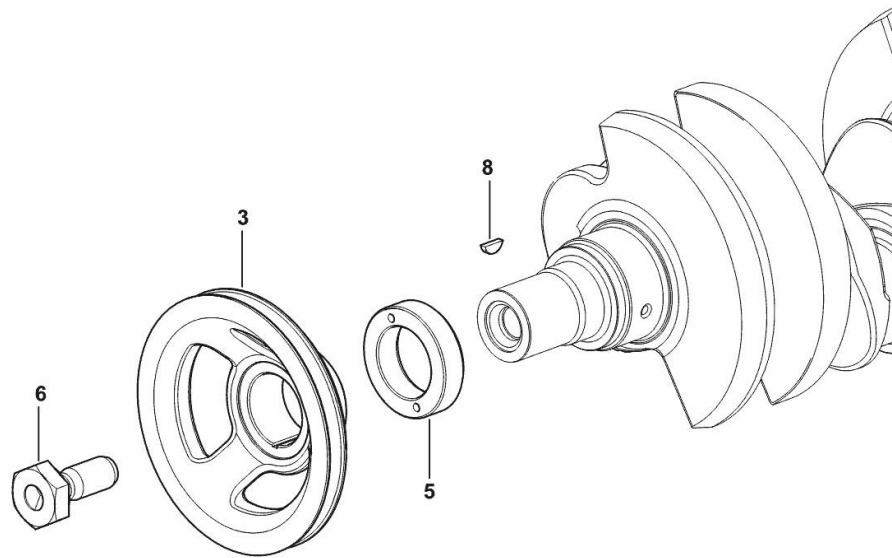

19\_33312\_02\_0-A-001

**BELT**

Fig.	P/n	QTY	Name
------	-----	-----	------

Notes:  
[TIGER 80.4 E 2WD ->S10S714WX1E40001] [TIGER 80.4 E 4WD ->S10S714WT1E40001]

3	2.4119.198.0	1	vee belt AV 10.7x1240 mm
---	--------------	---	--------------------------

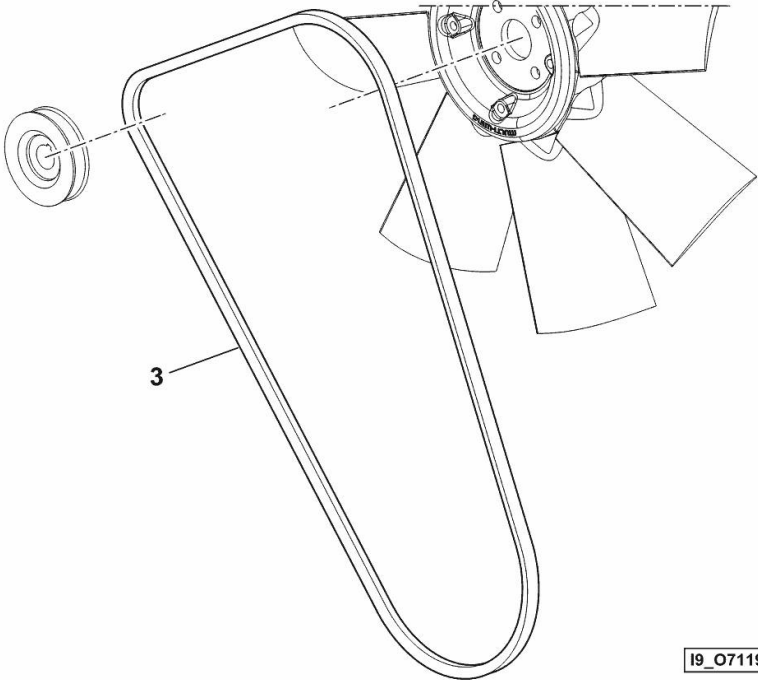



**Suggest:**

**For more complete manuals. Please go to the home page.**

**<https://www.ebooklibonline.com>**

**If the above button click is invalid. Please download this document first, and then click the above link to download the complete manual.**

**Thank you so much for reading**

COUNTERWEIGHTS

Fig.	P/n	QTY	Name
------	-----	-----	------

Notes:

[TIGER 80.4 E 2WD ->S10S714WX1E40001] [TIGER 80.4 E 4WD ->S10S714WT1E40001]

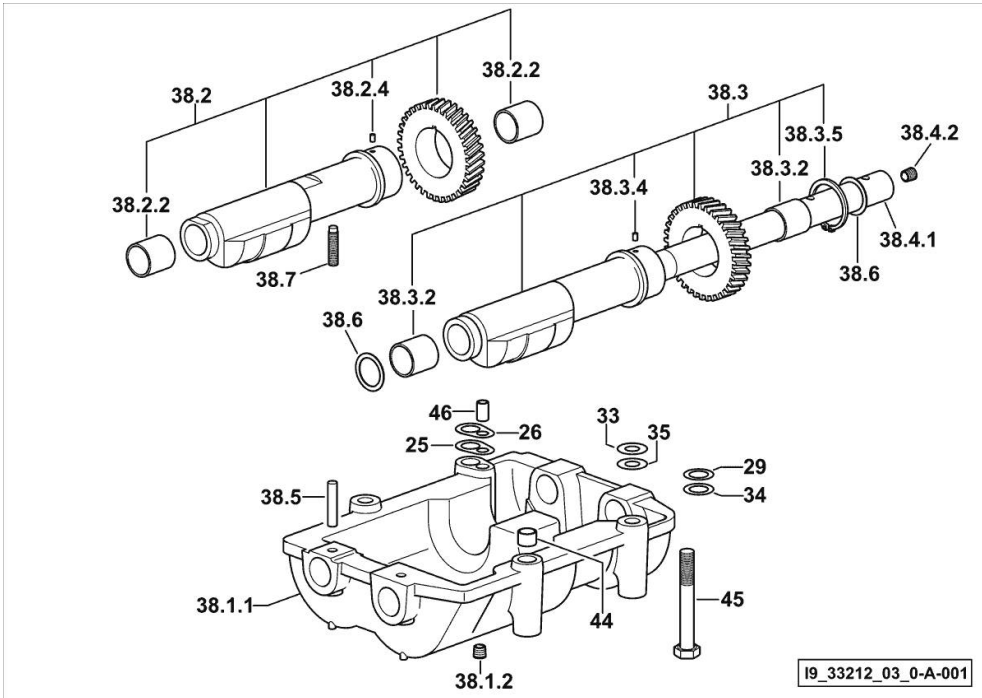

25	2.1589.139.0	1	shoulder ring mm 0.3
26	2.1589.140.0	3	shoulder ring mm 0.1
29	2.1579.628.0	3	spacer 16.5x26x0.1
33	2.1579.629.0	6	spacer 12.5x26x0.1
34	2.1589.048.0	1	shoulder ring 16.5x26x0.3
35	2.1589.049.0	1	shoulder ring 12.5x26x0.3
38.1.1	0.086.1231.0/10	1	box
38.1.2	2.3130.001.1	4	plug 1/8" gas
38.2	0.086.1233.3/30	1	mass sx/lh/li
38.2.2	2.1559.115.0	2	special bushing 26x30x30
38.2.4	2.1651.302.0	1	roll pin 4x6
38.3	0.065.1233.3/30	1	mass dx/rh/re
38.3.2	2.1559.115.0	2	special bushing 26x30x30
38.3.4	2.1651.302.0	1	roll pin 4x6
38.3.5	2.1410.018.1	1	circlip 45
38.4.1	0.065.1234.0/10	1	shaft
38.4.2	2.3130.001.1	1	plug 1/8" gas
38.5	2.1631.717.0	2	roll pin 8 x 40
38.6	2.1589.185.0	4	shoulder ring 26.1x34x1
38.7	2.0522.212.7	1	screw m 8 p.1.25 x 30
44	2.1579.626.0	2	spacer 13.2x16x11
45	2.0139.028.2	4	screw m 12
46	2.1699.191.0	1	bush 7x10x16

**CYLINDER - PISTON - CONNECTING ROD**

Fig.	P/n	QTY	Name
------	-----	-----	------

**Notes:**

[TIGER 80.4 E 2WD ->S10S714WX1E40001] [TIGER 80.4 E 4WD ->S10S714WT1E40001]

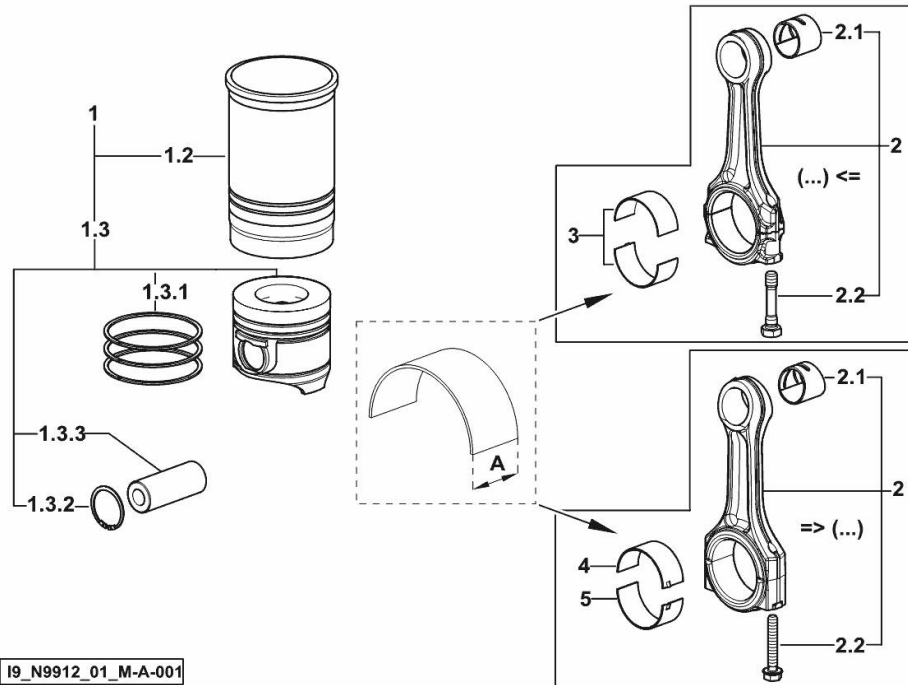

1	0.386.0065.A	4	cyl. piston assembly "A" - CLASS A
1	0.386.0065.B	4	cyl. piston assembly "B" - CLASS B
1.2	0.A12.2675.0	1	engine cylinder "A" - CLASS A
1.2	0.B12.2675.0	1	engine cylinder "B" - CLASS B
1.3	0.379.0060.A	1	complete piston "A" - CLASS A
1.3	0.379.0060.B	1	complete piston "B" - CLASS B
1.3.1	0.086.0052.6/10	1	piston ring set
1.3.2	2.1411.014.1	2	circlip 35
1.3.3	0.078.1236.0	1	piston pin Ø 18 / Ø 35 / L = mm 86
2	0.019.2226.3/10	4	engine connecting rod => (...)
2	0.078.1220.3/30	4	engine connecting rod (...) <=
2.1	2.1559.114.0/10	1	special bushing (...) <=
2.1	2.1559.532.0	1	special bushing 34.60x39.130x36.65 => (...)
2.2	2.0399.213.0	2	screw m 12 p.1.25x61.5 (...) <=
2.2	2.0399.365.0	2	screw m 10 p.1.25x61.5 => (...)
3	0.065.1225.0	8	con.rod half bushing STANDARD - A = 28.75 -> 29.00 (...) <=
3	0.065.1225.7	8	con.rod half bushing - mm 0.25 (...) <=
3	0.065.1225.8	8	con.rod half bushing - mm 0.50 (...) <=
4	0.019.5453.0	4	con.rod half bushing STANDARD - A = 29.85 -> 30.10 => (...)
5	0.019.5454.0	4	con.rod half bushing STANDARD - A = 29.85 -> 30.10 => (...)

**<https://www.ebooklibonline.com>**

Hello dear friend!

Thank you very much for reading.

Enter the link into your browser.

The full manual is available for immediate download.

**<https://www.ebooklibonline.com>**