

Section: ENGINE

**CRANKCASE**

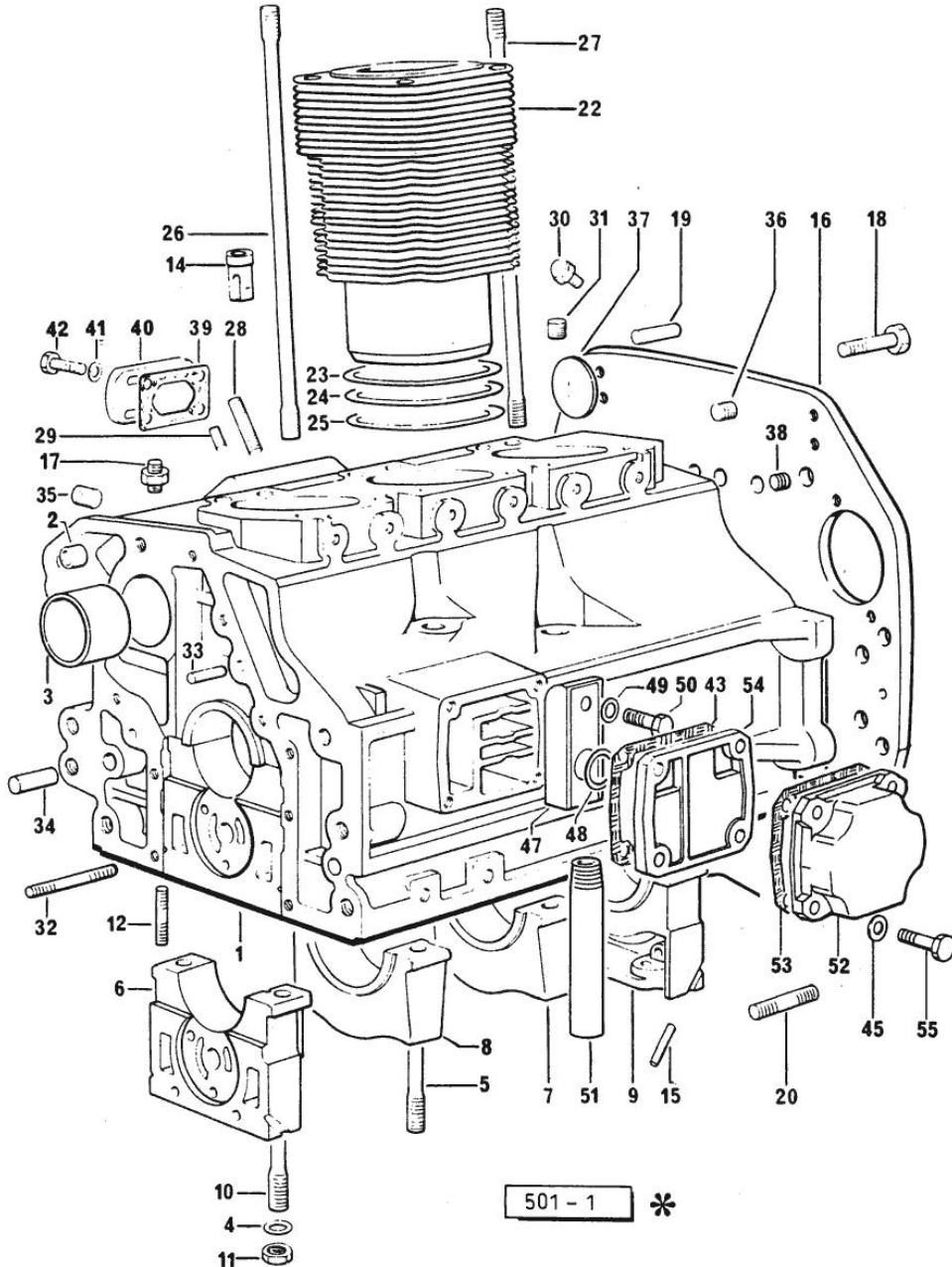

Fig.	P/n	QTY	Name
<b>Notes:</b>			
[SOLAR 60 -> 4500]			
0	0.054.0050.6	1	gasket set - FOR ENGINE MOUNTING
1	0.054.1110.4/40	1	crankcase
2	2.1559.111.0/10	2	special bushing 11.5x14.1x10
3	0.037.1155.0	1	bushing
4	2.1599.144.7	8	shoulder ring 12.5x23x4
5	0.029.1117.0	4	stud bolt
6	0.054.1112.0	1	support
7	0.037.1114.0	1	support
8	0.029.1113.0	1	support
9	0.029.1116.0	1	support
10	0.021.1157.0	4	stud bolt
11	2.1019.026.7	8	special nut m 12 p.1.5
12	2.0432.003.7	24	stud bolt m 8 p.1.25 / p.1 x 20
14	0.044.1156.0	6	special bushing
15	0.029.1154.0/10	4	gasket
16	0.045.1152.0/10	1	plate
17	0.054.1152.0	1	pipe fitting
18	2.0112.511.1	11	screw m 14 p.2 x 30
19	2.1652.911.0	2	cylindrical plug 12x25
20	2.0432.153.7	2	stud bolt m 10 p.1.5 / p.1.25 x 20
22	0.044.1120.0/10	3	engine cylinder
23	2.1589.052.0	7	shoulder ring 115x123x0.2
24	2.1589.051.0	3	shoulder ring 116x123x0.1
25	2.1569.076.0	3	gasket 116x123x0.5
26	0.041.1123.0/10	3	stud bolt
27	0.039.1122.0	12	stud bolt m 12 p.1.5x310
28	2.0432.003.7	4	stud bolt m 8 p.1.25 / p.1 x 20
29	2.1652.306.0	1	cylindrical plug 4x14
30	0.071.1151.3	3	valve
31	2.3130.001.1	2	plug 1/8" gas
32	2.0432.025.7	2	stud bolt m 8 p.1.25 - 1.00 x 100
33	2.1653.711.0	1	pin
34	2.1699.114.0	1	pin 8x55
35	2.3139.001.1	3	plug
36	2.3130.002.1	1	plug 1/4" gas
37	2.3170.022.1	1	expansion plug 60
38	2.3130.003.1	2	plug 3/8" gas
39	0.044.1151.0	1	gasket
40	0.044.1164.2/10	1	small cover
41	2.1310.004.2	4	flat washer 8.4x17

Section: ENGINE  
**CRANKCASE**

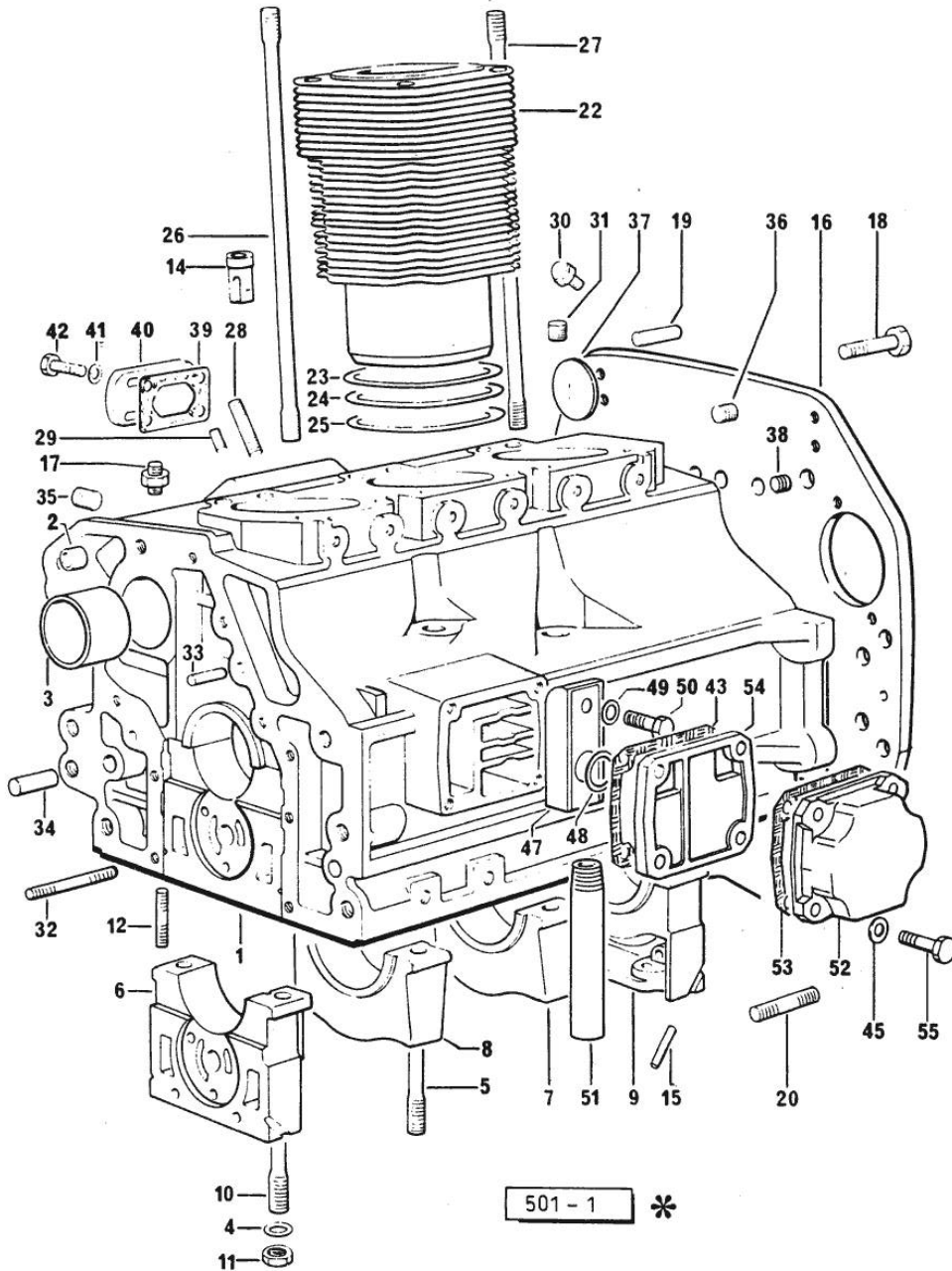

Fig.	P/n	QTY	Name
42	2.0112.204.2	2	screw m 8 p.1.25x14
43	0.044.1153.0/10	1	gasket
45	2.1474.009.2	4	spring washer 8
47	0.071.1155.2	1	small guard
48	0.071.1156.0	1	special oil seal
49	2.1474.009.2	1	spring washer 8
50	2.0312.206.2	1	screw m 8 p 1.25 x 20
51	0.044.1152.0/10	1	tube
52	0.071.1154.0	1	small cover
53	0.044.1153.0/10	1	gasket
54	0.071.1153.0	1	small cover
55	2.0112.211.2	4	screw m 8 p.1.25 x 30

Section: ENGINE

**TIMING CASE**

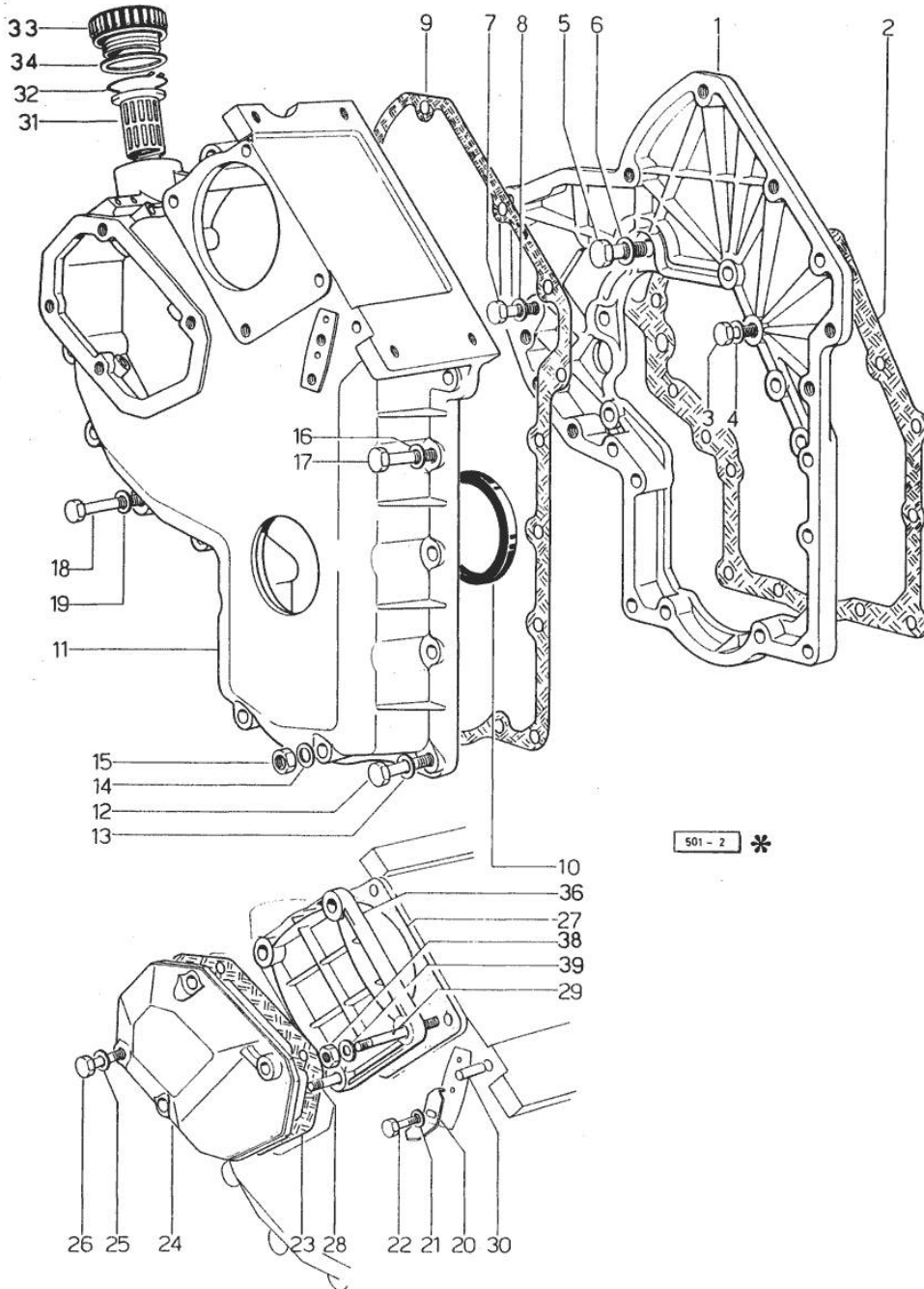

Fig.	P/n	QTY	Name
------	-----	-----	------

Notes:  
[SOLAR 60 -> 4500]

1	0.048.1131.0	1	flange
2	0.041.1153.0	1	gasket
3	2.0112.209.2	2	screw m 8 p 1.25 x 25
3	2.0112.211.2	3	screw m 8 p.1.25 x 30
4	2.1474.009.2	5	spring washer 8
5	2.0119.034.1	1	screw m 14 p.2x20
6	2.1560.010.0	1	gasket 14.2 x 20
7	2.0112.207.2	1	screw m 8 p 1.25 x 20
8	2.1474.009.2	1	spring washer 8
9	0.041.1152.0	1	gasket
10	2.1519.010.0	1	special oil seal 58x80x10
11	0.048.1132.0/40	1	guard
12	2.0112.217.2	5	screw m 8 p.1.25 x 45
13	2.1474.009.2	5	spring washer 8
14	2.1560.003.0	2	copper gasket 8.2 x 12
15	2.1011.405.2	1	nut m 8 p.1
16	2.1474.009.2	2	spring washer 8
17	2.0112.211.2	2	screw m 8 p.1.25 x 30
18	2.0112.222.2	4	screw m 8 p.1.25x65
19	2.1474.009.2	4	spring washer 8
20	0.041.1158.0	1	index
21	2.1310.004.2	1	flat washer 8.4x17
22	2.0112.204.2	3	screw m 8 p.1.25x14
23	0.048.1151.0/10	1	gasket
24	0.048.1150.0/20	1	cover
25	2.1560.006.0	4	gasket 10.2 x 16
26	2.0112.315.2	4	screw m 10 p.1.5 x 40
27	0.041.1154.0	2	gasket
28	2.0432.015.7	1	stud bolt m 8 p.1.25-1x50
29	2.0432.028.7	3	stud bolt m 8 p.1.25-1x130
30	2.1653.717.0	1	pin 8 x 40
31	0.041.1159.0/10	1	filter
32	2.1411.012.1	1	circlip 30
33	0.041.1135.4	1	plug 1" gas
34	2.1569.072.0	1	gasket 32 x 39.5 x 2
36	0.037.1151.0/10	1	cover
38	2.1011.505.2	4	nut m 8 p.1
39	2.1310.004.2	4	flat washer 8.4x17

**<https://www.ebooklibonline.com>**

Hello dear friend!

Thank you very much for reading.

Enter the link into your browser.

The full manual is available for immediate download.

**<https://www.ebooklibonline.com>**

Section: ENGINE

**CRANKSHAFT**

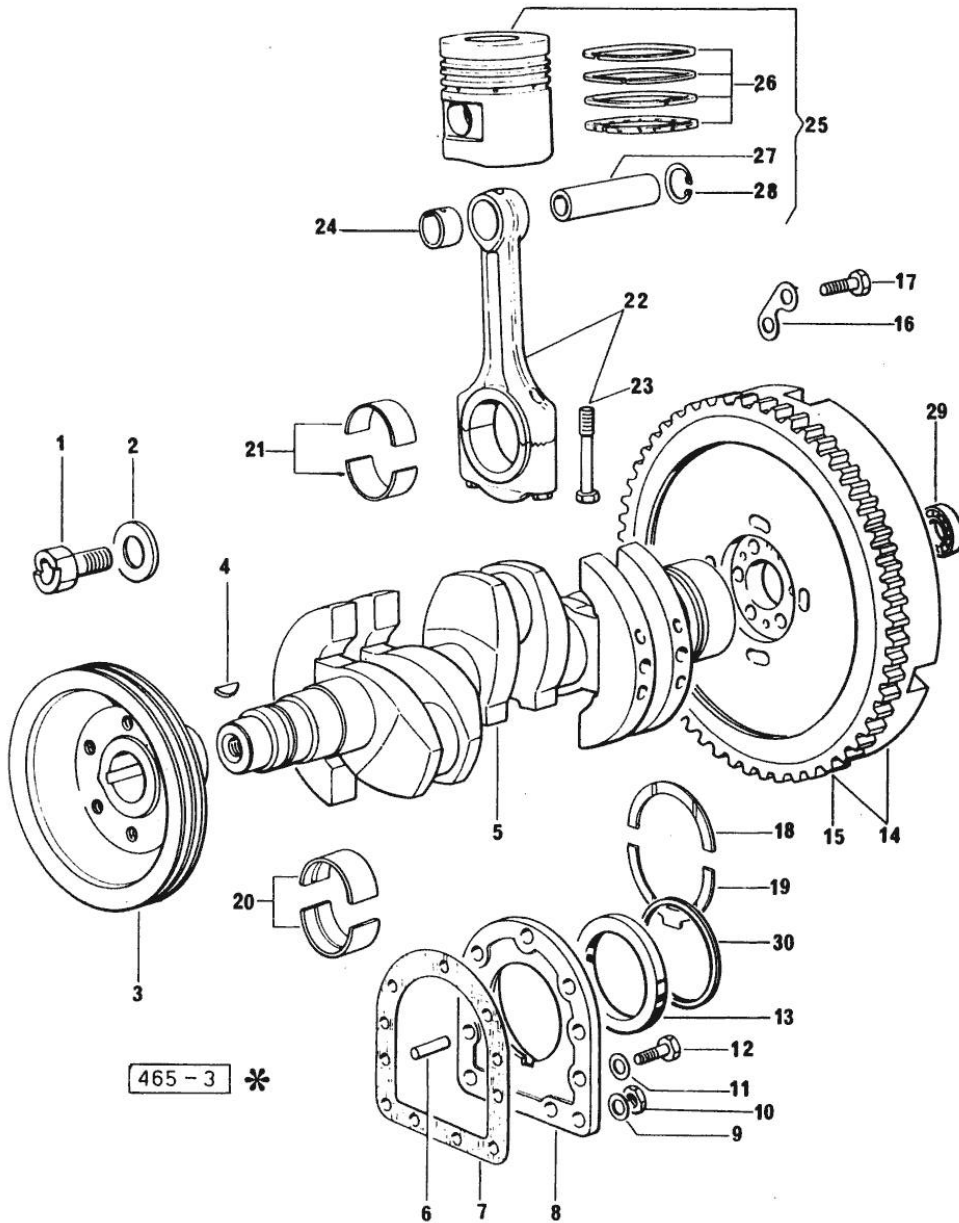

Fig.	P/n	QTY	Name
------	-----	-----	------

Notes:  
[SOLAR 60 -> 4500]

1	2.0129.032.2	1	screw m 24 p.2x45
2	0.001.6020.0	1	shoulder
3	0.062.1250.0	1	pulley
4	2.1799.026.0	1	key 10x10
5	0.053.1210.4/10	1	crankshaft
6	2.1652.915.0	2	cylindrical plug 12x35
7	0.029.1250.0/10	1	gasket
8	0.045.1240.0	1	flange
9	2.1560.006.0	2	gasket 10.2 x 16
10	2.1011.421.2	2	nut m 10 p.1.25
11	2.1474.010.2	9	washer 10
12	2.0112.309.2	9	screw m 10 p.1.5 x 25
13	2.1529.045.0	1	oil seal
14	0.068.1241.3	1	flywheel
15	0.036.1242.0	1	crown wheel Z = 126, mm 15
16	2.1379.006.0	3	lock-tab 15x15x36,5
17	2.0122.515.7	6	screw
18	0.001.4544.0	2	shoulder ring + mm 0.05
18	0.001.4545.0	2	shoulder ring + mm 0.10
18	0.001.4546.0	2	shoulder ring + mm 0.15
18	0.042.1218.0	2	shoulder ring STANDARD
19	0.001.4547.0	2	shoulder ring + mm 0.05
19	0.001.4548.0	2	shoulder ring + mm 0.10
19	0.001.4549.0	2	shoulder ring + mm 0.15
19	0.042.1219.0	2	shoulder ring STANDARD
20	0.073.1215.0	8	main half bushing STANDARD
20	0.073.1215.7	8	main half bushing - mm 0.25
20	0.073.1215.8	8	main half bushing - mm 0.50
20	0.073.1215.9	8	main half bushing - mm 0.75
21	0.039.0068.0	6	con.rod half bushing - mm 1.016
21	0.062.1225.0	6	con.rod half bushing STANDARD
21	0.062.1225.7	6	con.rod half bushing - mm 0.25
21	0.062.1225.8	6	con.rod half bushing - mm 0.50
21	0.062.1225.9	6	con.rod half bushing - mm 0.75
22	0.039.1220.3/30	3	engine connecting rod
23	0.039.1250.0	2	screw m 14 p.1.5x63
24	2.1559.114.0/10	1	special bushing
25	0.054.0060.6/10	3	complete piston STANDARD
25	0.054.0061.6/10	3	complete piston + mm 0.50
25	0.054.0062.6/10	3	complete piston + mm 1.0
26	0.073.0052.6	3	piston ring set

Section: ENGINE  
**CRANKSHAFT**

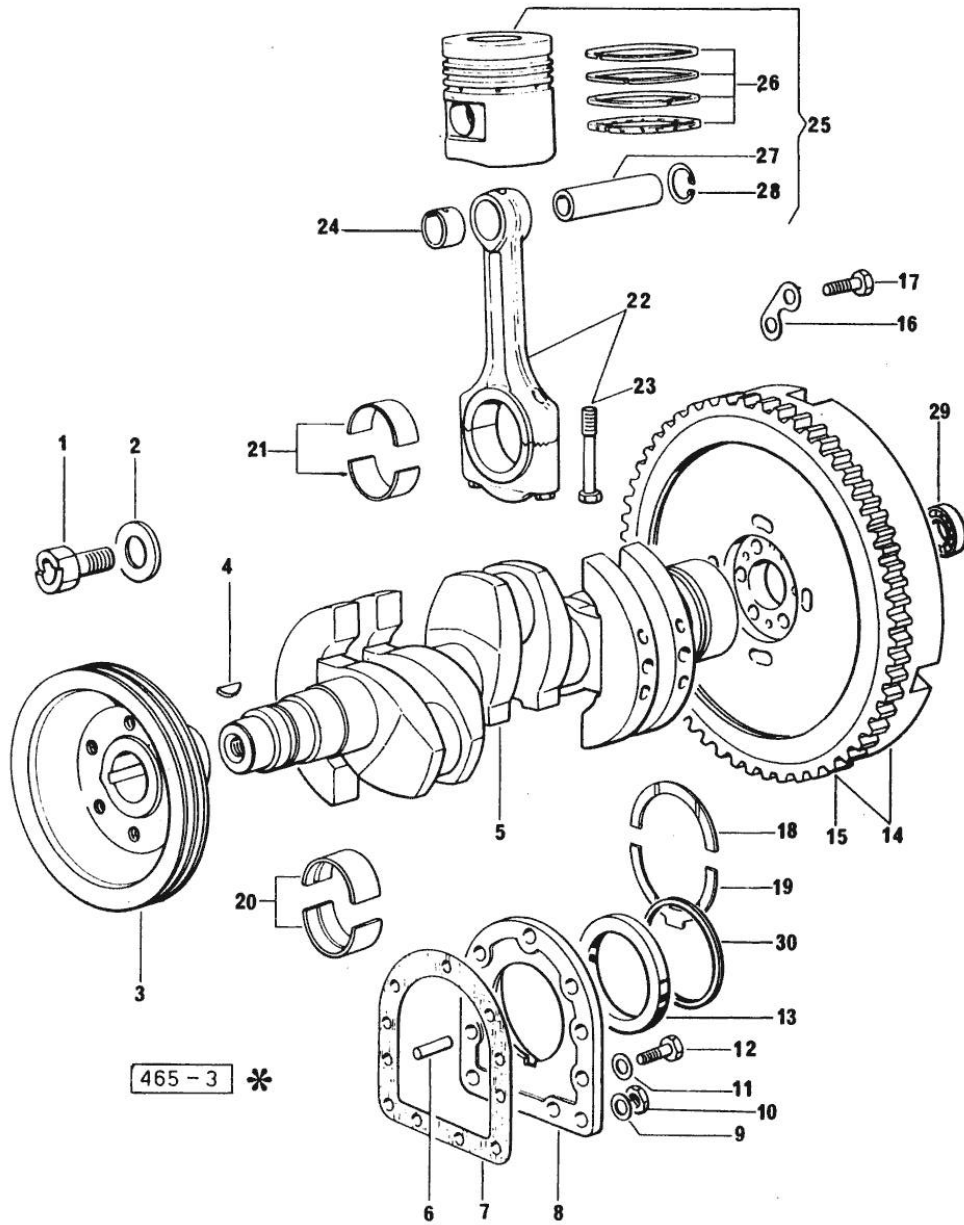

Fig.	P/n	QTY	Name
26	0.073.0053.6	3	piston ring set + mm 0.5
26	0.073.0054.6	3	piston ring set + mm 1.0
27	0.002.4167.0	3	piston pin
28	2.1411.014.1	6	circlip 35
29	2.2041.008.0	1	ball bearing 20x47x14
30	2.1599.404.0	1	shoulder ring

Section: ENGINE

**CAMSHAFT**

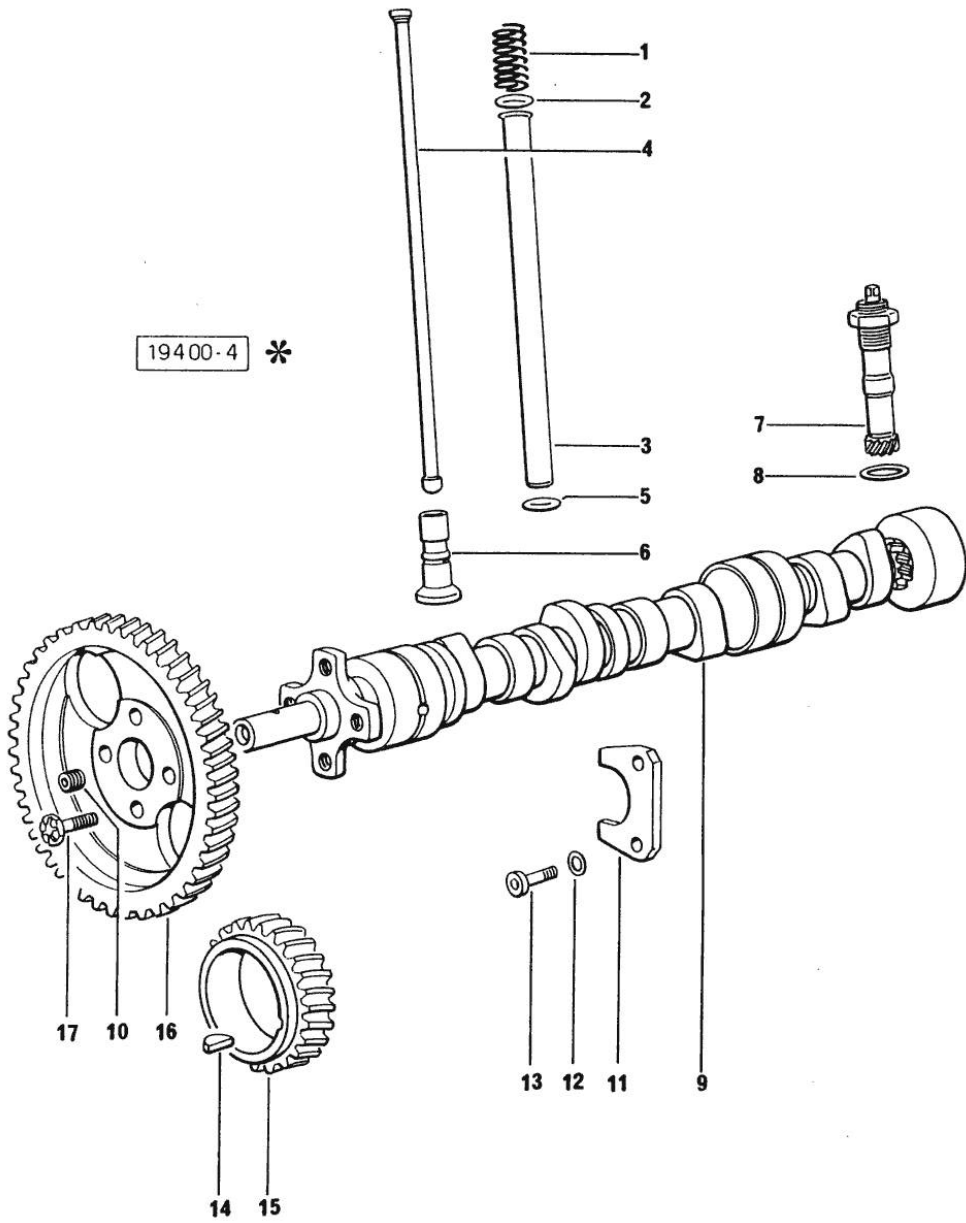

Fig.	P/n	QTY	Name
------	-----	-----	------

Notes:  
[SOLAR 60 -> 4500]

1	2.4019.162.1/20	14	spring 17.2x46x1.8
2	2.1539.022.0	6	special oil seal 12.37x2.62
3	0.041.1332.0	6	sleeve
4	0.041.1331.3	6	rod
5	2.1539.020.0	6	special oil seal 13.95x2.62
6	0.052.1330.0/20	6	tappets
7	0.041.1355.3	1	transmission
8	2.1560.013.0	1	gasket 18.2x22
9	0.054.1310.0/20	1	camshaft
10	2.3130.001.1	1	plug 1/8" gas
11	0.027.1314.0	1	flange
12	2.1470.004.2	2	lock washer 8
13	2.0112.207.2	2	screw m 8 p 1.25 x 20
14	2.1720.010.0	1	key 5x9
15	0.040.1320.0	1	gear z = 33
16	0.062.1321.0	1	gear z=66
17	2.0139.005.1	4	screw m 10 p.1 x 25

Section: ENGINE  
CYLINDER HEAD

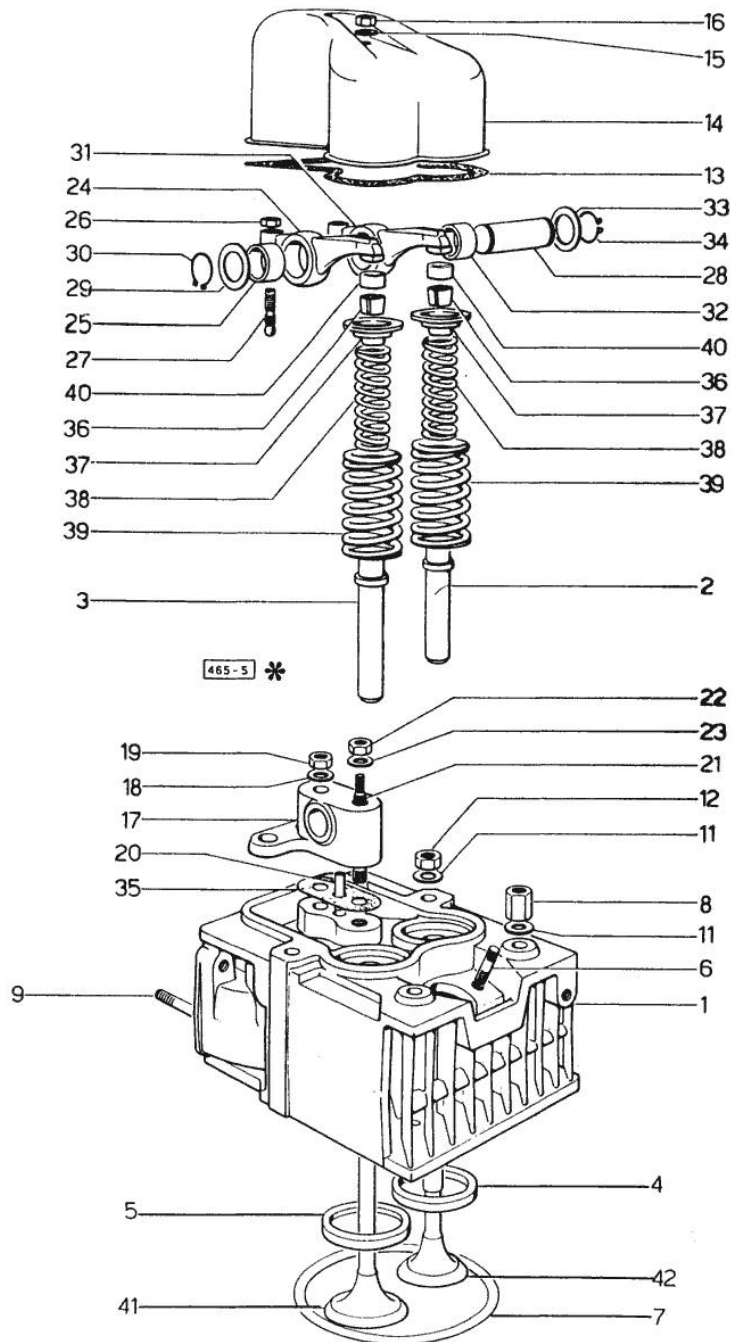

Fig.	P/n	QTY	Name
<b>Notes:</b>			
[SOLAR 60 -> 4500]			
0	0.073.0057.6	1	gasket set - FOR 1 CYLINDER VALVE GRINDING AND PISTON RINGS REPLACEMENT
1	0.062.1410.3/10	3	engine head
2	0.062.1417.0/10	3	valve guide
3	0.062.1416.0/10	3	valve guide
4	0.062.1450.0/10	3	valve seat
5	0.062.1451.0/10	3	valve seat
6	2.0439.087.1/20	6	stud bolt m 8 p.1.25 / p.1 x 40
7	2.1569.078.0/10	3	gasket 106x118x0.5
8	2.1019.037.0	5	special nut m 12 p.1.5
9	2.0432.005.7	6	stud bolt m 8 p.1.5 / p.1 x 25
9	2.0432.007.7	3	stud bolt m 8 p.1.25 / p.1 x 30
9	2.0432.009.7	1	stud bolt m 8 p.1.25 / p.1 x 35
11	2.1599.406.0	12	shoulder ring
12	2.1019.025.0	7	special nut m 12 p.1.5
13	0.029.1450.0	3	gasket
14	0.039.1440.0	3	cap
15	2.1560.004.0	3	copper gasket 8.2 x 14
16	2.1099.056.2	3	special nut m 8 p.1 x 8
17	0.041.1430.0	3	support
18	2.1599.160.0	3	washer 10.5x19x4
19	2.1099.035.0	3	special nut m 10 p.1.25
20	0.029.1452.0	6	tube
21	0.039.1451.0	3	stud bolt
22	2.1011.421.2	3	nut m 10 p.1.25
23	2.1310.006.2	3	flat washer 10.5x21
24	0.002.4003.0	3	rocker arm
25	2.1559.021.0/40	3	bushing 15x19x22
26	2.1011.405.2	6	nut m 8 p.1
27	0.021.1434.0	6	screw
28	0.041.1431.0	3	pin
29	2.1599.019.0	3	shoulder ring 19.5x31x2
30	2.1410.055.1	3	circlip 19
31	0.002.4004.0/20	3	rocker arm
32	2.1559.021.0/40	3	bushing 15x19x22
33	2.1599.019.0	3	shoulder ring 19.5x31x2
34	2.1410.055.1	3	circlip 19
35	0.034.1450.0	3	tappet gasket
36	0.062.1423.0/10	6	conical valve cotter
37	0.062.1425.0	6	cup

Section: ENGINE  
CYLINDER HEAD

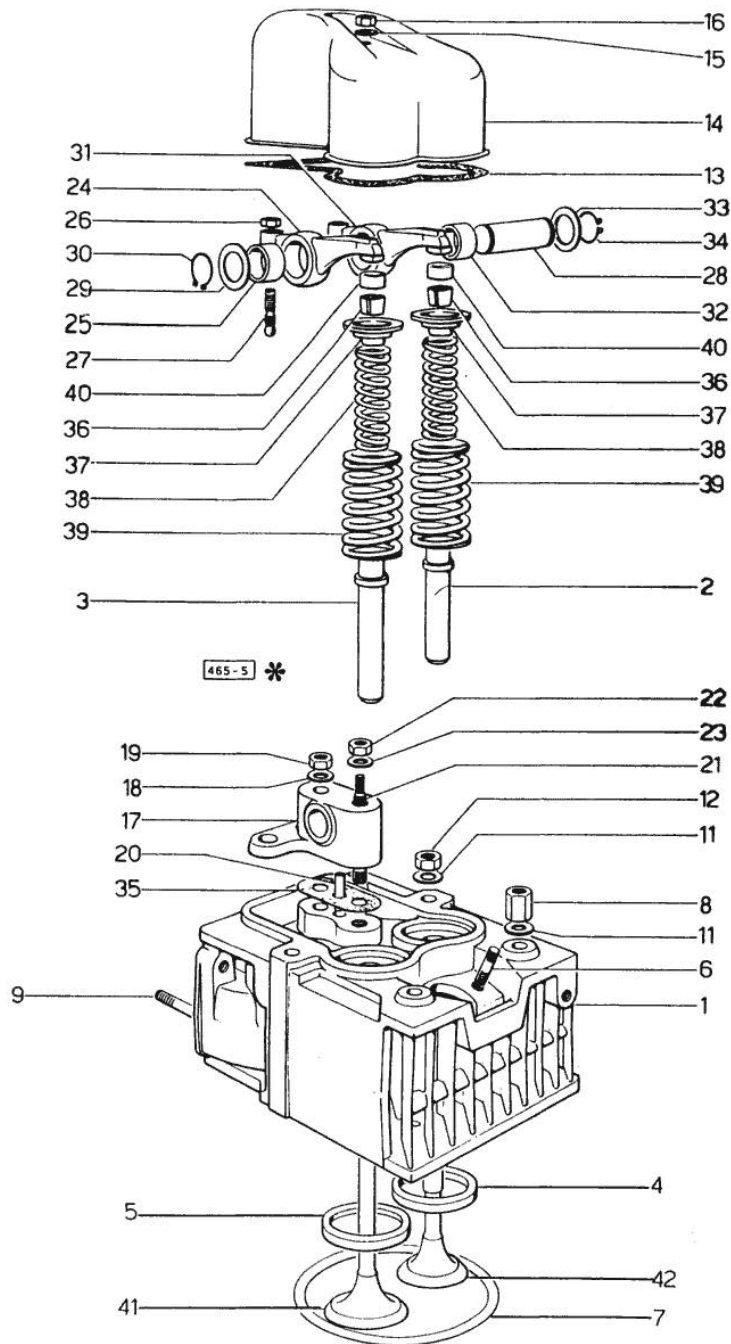

Fig.	P/n	QTY	Name
38	2.4019.194.0	6	spring 22.70x50.7x2.1
39	2.4019.193.0	6	spring 36.15x55.2x3.2
40	0.062.1452.0	6	small cover
41	0.042.1420.2	3	inlet valve Ø mm 8
42	0.071.1420.2	3	exhaust valve Ø mm 8



**Suggest:**

**For more complete manuals. Please go to the home page.**

**<https://www.ebooklibonline.com>**

**If the above button click is invalid. Please download this document first, and then click the above link to download the complete manual.**

**Thank you so much for reading**

Section: ENGINE  
LUBRICATION

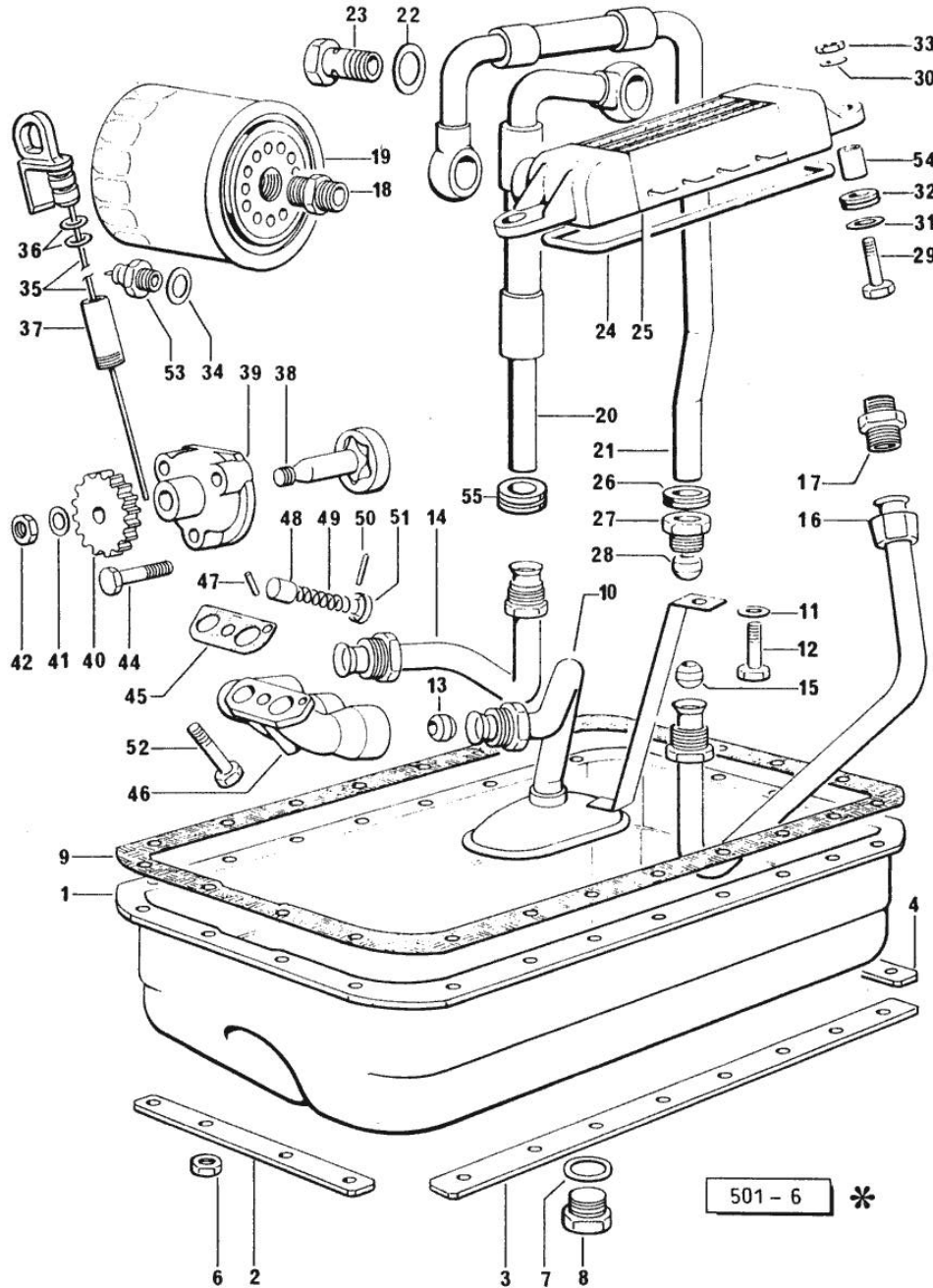

Fig.	P/n	QTY	Name
------	-----	-----	------

Notes:  
[SOLAR 60 -> 4500]

1	0.054.1510.2/10	1	oil sump
2	0.053.1550.0/10	1	small plate
3	0.035.1551.0/10	2	small plate
4	0.053.1551.0	1	small plate
6	2.1121.105.2	24	nut m 8 x 1
7	2.1560.054.0	1	gasket 21 x 26
8	2.3199.001.2	1	plug 1/2" gas
9	0.029.1512.2	1	gasket
10	0.054.1531.3/10	1	tube
11	2.1310.004.2	1	flat washer 8.4x17
12	2.0112.204.2	1	screw m 8 p.1.25x14
13	2.3359.016.1	2	nosepiece
14	0.054.1542.2/10	1	tube
15	2.3359.015.1	2	nosepiece
16	0.044.1543.2/30	1	tube
17	2.3339.159.1/10	1	pipe fitting
18	2.3339.094.1/10	1	pipe fitting m 20 p.1.5-3/4 gas
19	0.044.1567.0	1	oil filter element
20	0.054.1551.2/10	1	tube
21	0.054.1552.2/20	1	tube
22	2.1560.018.0	4	gasket 22.2 x 29
23	2.3339.107.1	2	pipe union m 22
24	0.054.1541.0	1	gasket
25	0.054.1540.2/10	1	oil cooler
26	2.6560.013.0	1	wire guide 18x1.5
27	2.3339.167.2	2	pipe fitting
28	2.3359.012.0	2	nosepiece 10x16.8
29	2.0112.211.2	2	screw m 8 p.1.25 x 30
30	2.1310.004.2	2	flat washer 8.4x17
31	2.1599.006.2	4	shoulder ring 8.4x25x2
32	0.021.1560.0	4	rubber plug
33	2.1011.105.2	2	nut m 8 p.1.25
34	2.1560.008.0	1	gasket 12.2 x 18
35	0.068.1513.2	1	dipstick
36	2.1539.065.0	2	special oil seal 8.73 x 1.78
37	0.044.1555.0	1	spacer
38	0.054.1524.3/10	1	rotor
39	0.054.1520.0	1	pump casing
40	0.054.1521.0	1	gear
41	2.1310.006.2	1	flat washer 10.5x21
42	2.1121.107.2	1	self-locking nut m 10 p 1.25

Section: ENGINE  
LUBRICATION

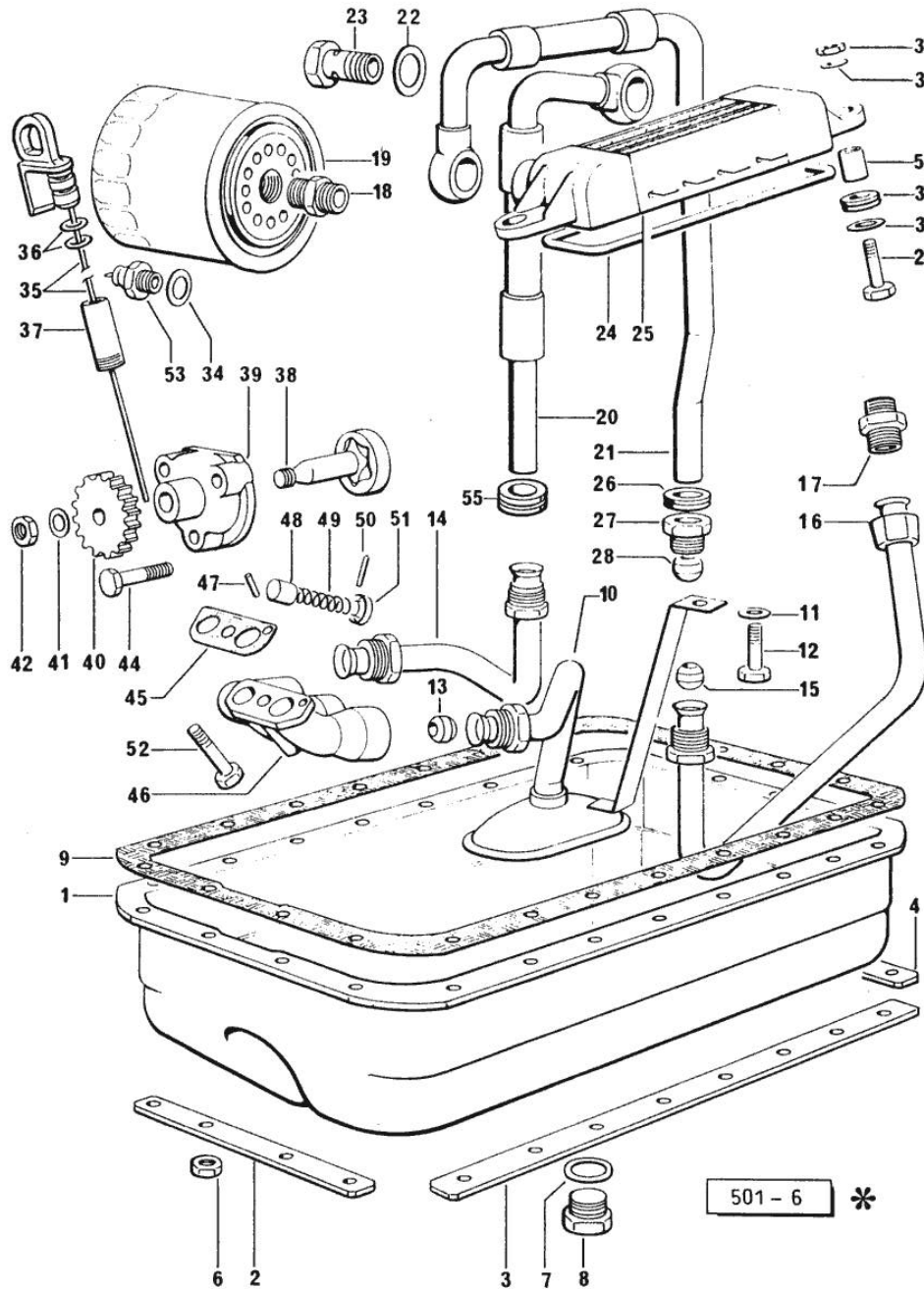

Fig.	P/n	QTY	Name
44	2.0112.215.2	3	screw m 8 p.1.25 x 40
45	0.054.1550.0	1	gasket
46	0.054.1530.0/20	1	tip
47	2.1651.305.0	1	pin 4 x 12
48	0.052.1571.0	1	small piston
49	2.4019.270.1	1	spring 9.7x54x2
50	2.1630.213.0	1	roll pin 3x32
51	0.054.1558.0/20	1	stop
52	2.0132.213.2	1	screw
53	2.7099.040.0/10	1	pressure switch
54	0.427.6352.0	2	bushing 10x12x13
55	2.6560.022.0	1	wire guide 28x1.5

**<https://www.ebooklibonline.com>**

Hello dear friend!

Thank you very much for reading.

Enter the link into your browser.

The full manual is available for immediate download.

**<https://www.ebooklibonline.com>**