

Section: ENGINE
CRANKCASE

Fig.	P/n	QTY	Name
------	-----	-----	------

Notes:
 [SILVER 100.4]

1	0.087.0050.6/10		gasket set - X SILVER 80 - 90 - 100.4 - FOR ENGINE MOUNTING
1	0.334.0050.6/10		gasket set - X SILVER 100.4 - ASSEMBLY OF ENGINE WITH MECHANICAL GOVERNOR
8	2.1099.108.2	4	special nut m 10 p.1
9	2.1560.006.0	8	gasket 10.2 x 16
10	0.086.1550.2	4	sprayer nozzle
11	0.065.1160.3/20	4	valve
12	2.1532.072.0	1	oil seal 26.70x1.78
13	2.3199.405.2	1	plug m 28 p.1.5
16	2.0432.003.7	12	stud bolt m 8 p.1.25 / p.1 x 20
19	2.1539.130.0/10	4	special oil seal 117.07x3.53
20	0.007.0762.0/50	4	engine cylinder
25	0.066.1152.0/10	4	gasket
26	0.007.1140.6/10	1	crankcase
27	0.065.1112.7	1	support
28	2.1699.165.0	1	bush 12.3x15x16
29	0.065.1116.3	1	support
30	2.1699.165.0	1	bush 12.3x15x16
31	0.066.1151.0	1	pin
32	0.065.1141.0	1	special bushing 59X55X30
33	0.065.1140.0	4	special bushing 59X55X20
34	2.3179.012.0	1	plug 60
35	2.3130.001.1	11	plug 1/8" gas
36	2.3130.002.1	2	plug 1/4" gas
37	2.3130.003.1	7	plug 3/8" gas
38	2.3199.092.0	4	plug 8 x 12
39	0.065.1114.0/10	3	support
40	0.065.1117.0	10	screw m 12 x 100
41	2.1324.011.0	1	plug
42	2.0112.511.1	8	screw m 14 p.2 x 30
43	0.007.1655.0	1	flange
44	2.1651.912.0	2	cylindrical plug 12x28
45	2.1651.917.0	1	cylindrical plug 12x40
46	2.0432.257.7	1	stud bolt m 12 p.1.75 - 1.25 x 30
47	2.0439.250.7	1	stud bolt m 12 / m 10 x 30
48	0.011.9294.0/10	1	bush
52	2.1560.017.0	1	gasket 22.2 x 27

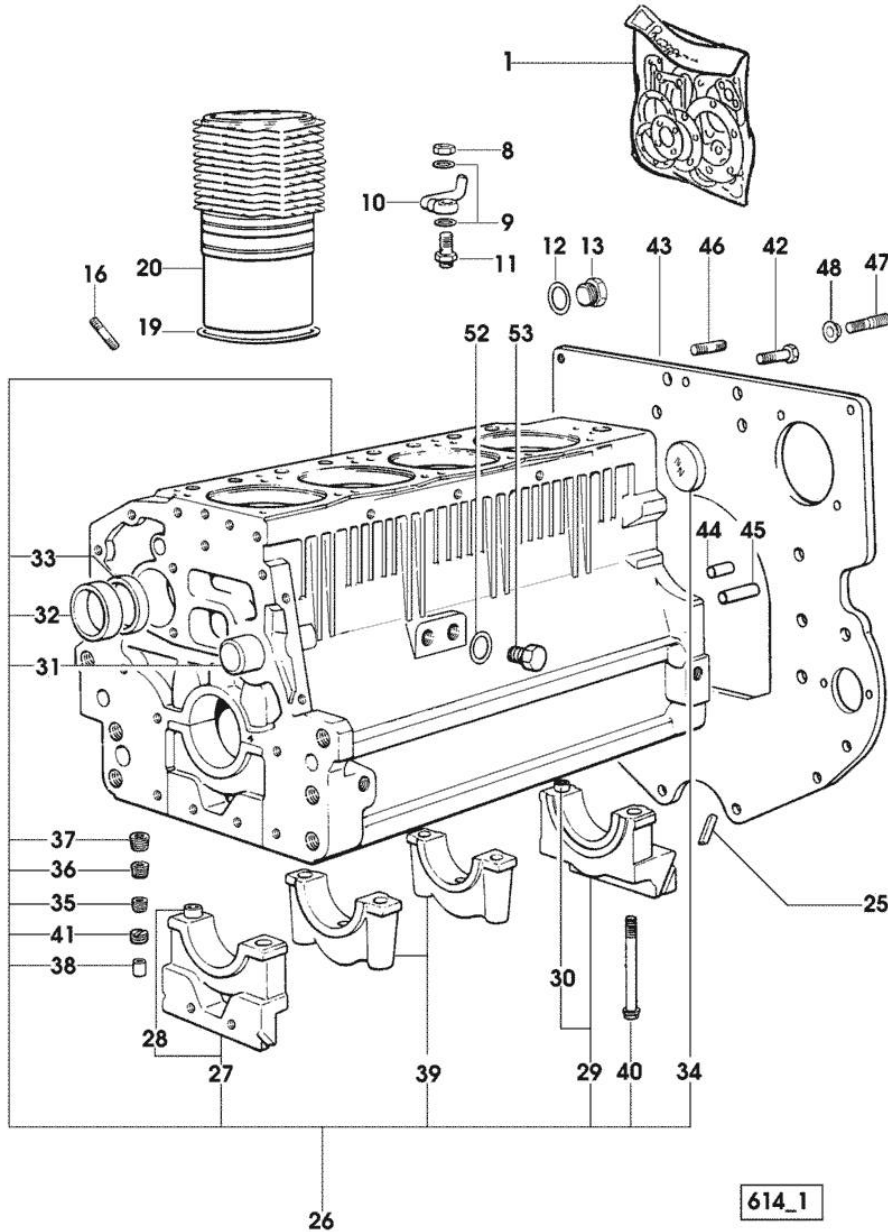

Section: ENGINE
CRANKCASE

Fig.	P/n	QTY	Name
53	2.3120.002.4	1	- X SILVER 80 plug m 22 x 1.5 - X SILVER 80

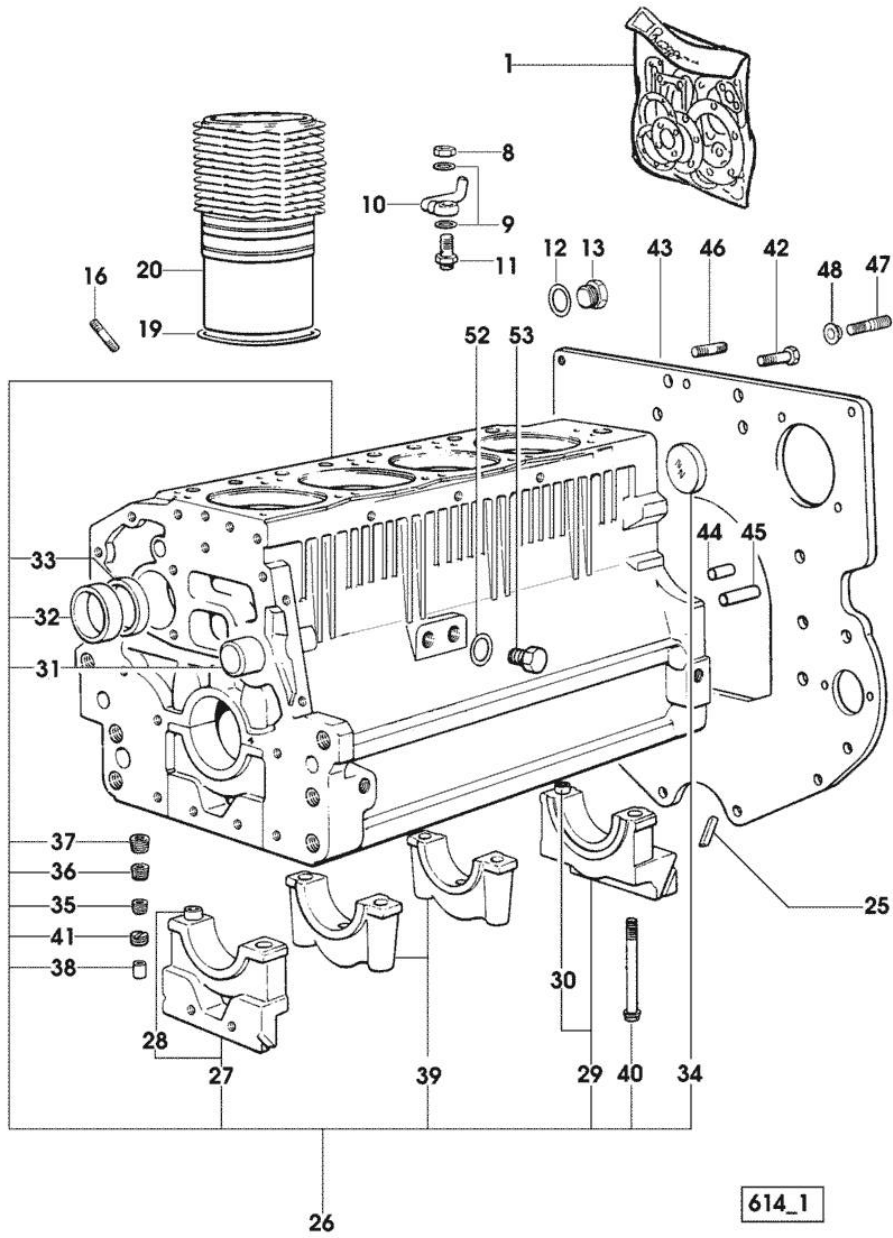

Section: ENGINE

TIMING CASE

Fig.	P/n	QTY	Name
------	-----	-----	------

Notes:

[SILVER 100.4]

1	0.007.1262.3/50	1	guard
2	0.007.1271.0/10	1	small column m 8 p.1.25 / L = mm 60
3	0.007.1272.0/10	2	small column m 8 p.1.25 / L = mm 50
5	2.1310.004.2	3	flat washer 8.4x17
7	2.0112.205.2	3	screw m 8 p.1.25 x 16

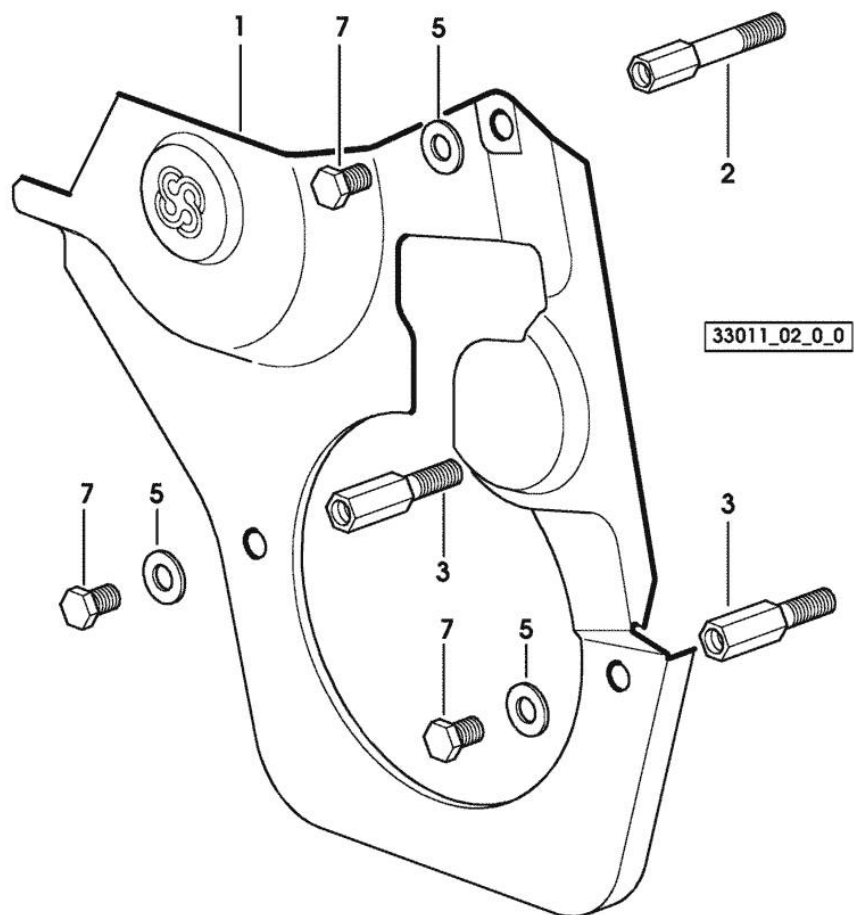

<https://www.ebooklibonline.com>

Hello dear friend!

Thank you very much for reading.

Enter the link into your browser.

The full manual is available for immediate download.

<https://www.ebooklibonline.com>

Section: ENGINE

TIMING CASE

Fig.	P/n	QTY	Name
------	-----	-----	------

Notes:

[SILVER 100.4]

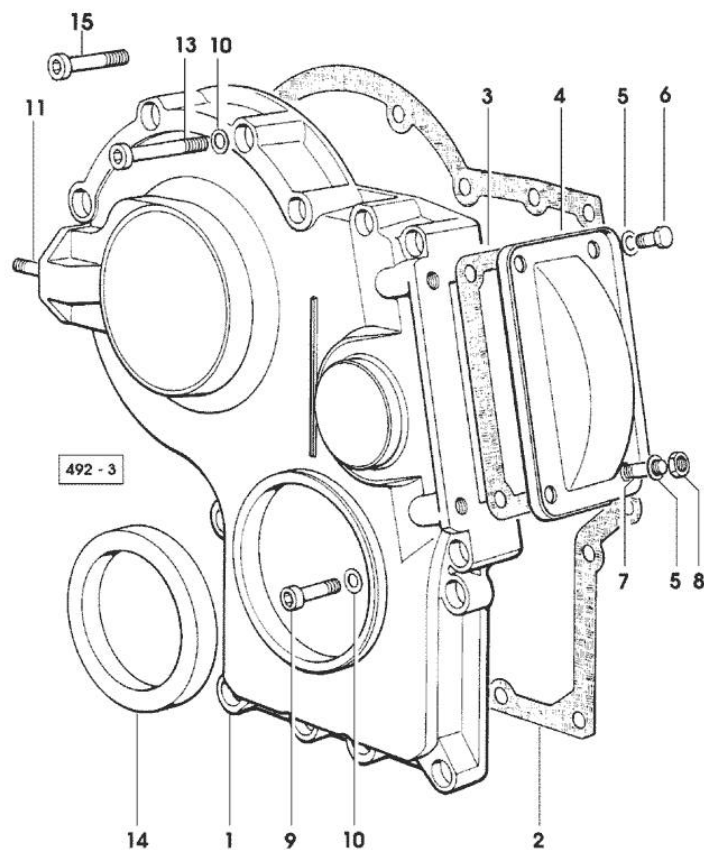

1	0.065.1132.0/60	1	guard
2	0.065.1150.0/30	1	gasket
3	0.065.1152.0	1	gasket
4	0.065.1151.0	1	cover
5	2.1470.004.2	4	lock washer 8
6	2.0112.205.2	2	screw m 8 p.1.25 x 16
7	2.0432.005.7	2	stud bolt m 8 p.1.5 / p.1 x 25
8	2.1011.405.2	2	nut m 8 p.1
9	2.0312.208.2	8	screw m 8 p.1.25 x 25
10	2.1480.014.1	15	washer 8
11	2.0432.003.7	2	stud bolt m 8 p.1.25 / p.1 x 20
13	2.0312.219.2	4	screw m 8 p.1.25x65
14	2.1529.141.0	1	special oil seal
15	2.0312.214.2	3	screw m 8 p.1.25 x 40

Section: ENGINE

CRANKSHAFT

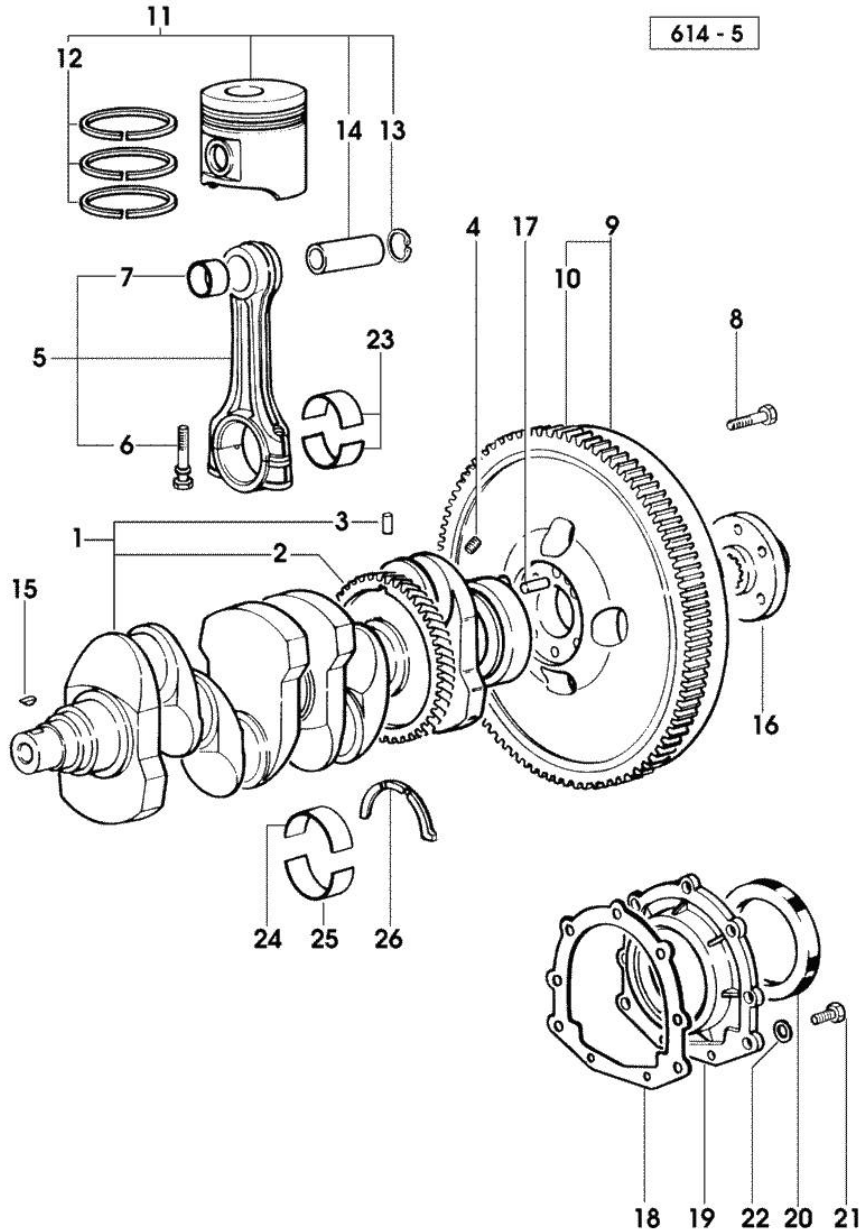

Fig.	P/n	QTY	Name
Notes:			
[SILVER 100.4]			
1	0.086.1210.3/30	1	crankshaft
2	0.065.1211.0/10	1	crown wheel
3	2.1630.608.0	1	pin 6x16
4	2.3130.001.1	4	plug 1/8" gas
5	0.078.1220.3/30	4	engine connecting rod
6	2.0399.213.0	2	screw m 12 p.1.25x61.5
7	2.1559.114.0/10	4	special bushing
8	2.0119.174.0/10	6	screw m 12 p.1.25x45 - X HYDRIVE
8	2.0139.022.2	6	screw m 12 p.1.25x55
9	0.007.1702.3/30	1	flywheel -> 2074 X SILVER 80 -> 2964 X SILVER 90 -> 1875 X SILVER 100.4
9	0.008.4049.3	1	flywheel mm 373 2073 <- X SILVER 80 2963 <- X SILVER 90 1874 <- X SILVER 100.4
9	0.010.7223.3/10	1	flywheel 2139 <- X SILVER 80 HYDRIVE 3042 <- X SILVER 90 HYDRIVE 1879 <- X SILVER 100.4 HYDRIVE
9	0.010.8727.3	1	flywheel -> 2140 X SILVER 80 HYDRIVE -> 3043 X SILVER 90 HYDRIVE -> 1880 X SILVER 100.4 HYDRIVE
10	0.065.1242.0	1	crown wheel Z = 123
11	0.086.0060.6/30	4	complete piston - X SILVER 80
11	0.338.0060.6/20	4	complete piston - X SILVER 90 - 100.4
11	0.379.0060.6	4	complete piston - X SILVER 80 - EXPORT U.S.A.
11	0.381.0060.6	4	complete piston - X SILVER 90 - 100.4 - EXPORT U.S.A.
12	0.086.0052.6/10	1	piston ring set - X SILVER 80
12	0.338.0052.6/10	1	piston ring set - X SILVER 90 - 100.4
13	2.1411.014.1	8	circlip 35
14	0.078.1236.0	4	piston pin Ø 18 / Ø 35 / L = mm 86

CRANKSHAFT

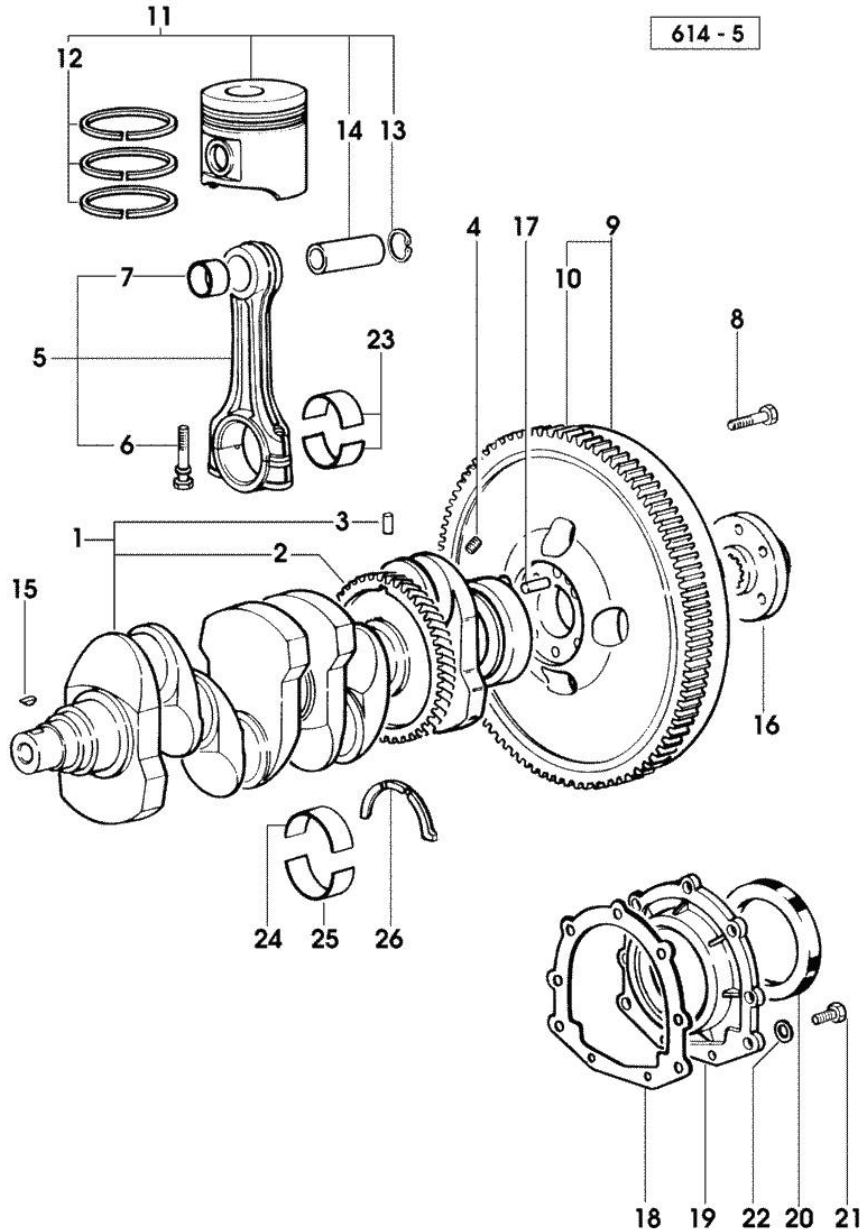

Fig.	P/n	QTY	Name
15	2.1720.006.0	1	key 4x6.5
16	0.008.5543.0	1	flange
17	2.1652.915.0	1	cylindrical plug 12x35
18	0.065.1254.0/20	1	gasket
19	0.007.1711.0/10	1	cover
20	2.1529.073.0	1	special oil seal 110x130x13
21	2.0112.207.2	9	screw m 8 p 1.25 x 20
22	2.1475.002.3	9	washer 8
23	0.065.1225.0	8	con.rod half bushing STANDARD - A = 28.75 -> 29.00
23	0.065.1225.7		con.rod half bushing - mm 0.25
23	0.065.1225.8		con.rod half bushing - mm 0.50
24	0.065.1215.0	5	main half bushing STANDARD
24	0.065.1215.7		main half bushing - mm 0.25
24	0.065.1215.8		main half bushing - mm 0.50
25	0.065.1216.0	5	main half bushing
25	0.065.1216.7		main half bushing - mm 0.25
25	0.065.1216.8		main half bushing - mm 0.50
26	0.065.1218.0	4	shim STANDARD
26	0.065.1218.7		shim + mm 0.10
26	0.065.1218.8		shim + mm 0.15

Section: ENGINE

ENGINE SHAFT - PULLEYS

Fig.	P/n	QTY	Name
------	-----	-----	------

Notes:
[SILVER 100.4]

1	0.007.6161.0	1	pulley * 1097 <= X SILVER 80 * 1159 <= X SILVER 90 * 1069 <= X SILVER 100.4 - N.1 - 007.6816.0
2	2.1589.136.0	2	shoulder ring 71x110x0.5
2	2.1589.137.0	2	shoulder ring 71x110x1
3	2.1470.006.2	6	lock washer 10
4	2.0112.322.2	6	screw m 10 p.1.5x65
5	2.0399.144.7/10	1	screw m 20 p.1.5x51
6	0.007.1645.0	1	spacer 2299 <- X SILVER 80 3775 <- X SILVER 90 2076 <- X SILVER 100.4
7	0.011.3512.0/10	1	hub
8	2.1720.006.0	1	key 4x6.5
9	2.1599.524.7	2	washer 21x60x12
10	2.1019.094.7	1	nut m 20 p.1.5
11	2.0439.195.7	1	stud bolt m 20 p.1.5x80
12	2.1579.865.0	1	spacer 45.2x51.8x10
13	0.065.1256.0	2	ring 45x52
15	0.011.3510.0/10	1	hub
16	0.007.6161.0	1	pulley - FOR ACCESSORIES

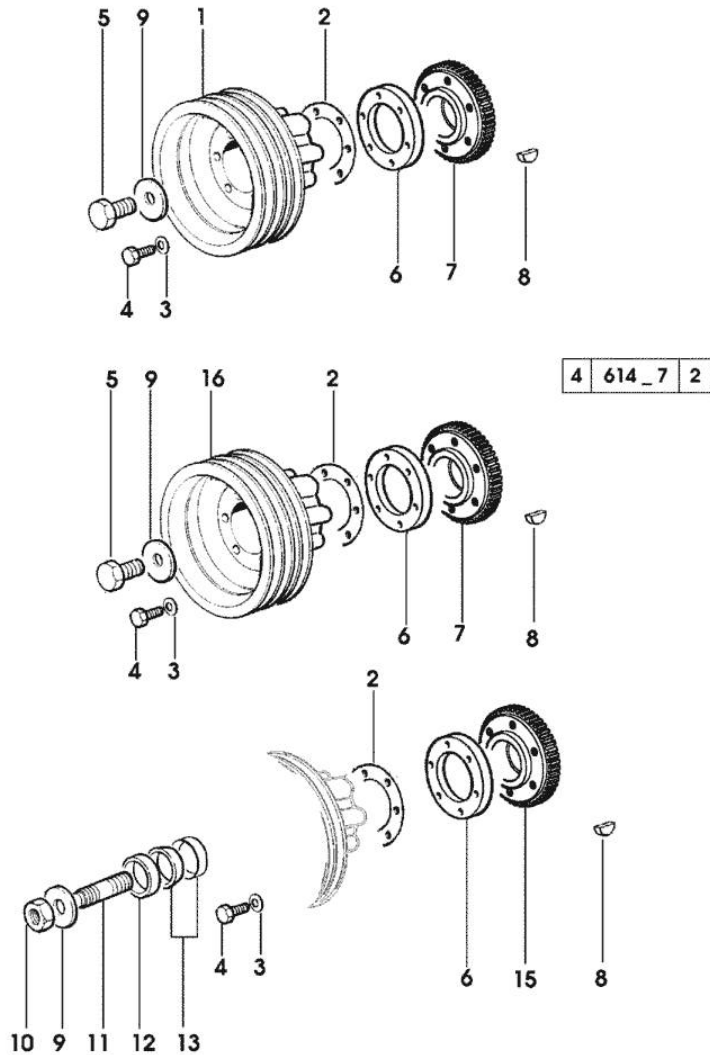

Section: ENGINE
COUNTERWEIGHTS

Fig.	P/n	QTY	Name
------	-----	-----	------

Notes:
 [SILVER 100.4]

1	0.086.1233.3/30	1	mass sx/lh/li
2	2.1559.115.0	2	special bushing 26x30x30
3	2.1652.302.0	1	roll pin 4x6
4	0.000.0000.1		cannot be supplied
5	0.065.1233.3/30	1	mass dx/rh/re
6	2.1410.018.1	1	circlip 45
7	2.1652.302.0	1	roll pin 4x6
8	2.1559.115.0	2	special bushing 26x30x30
9	0.000.0000.1		cannot be supplied
10	2.1589.185.0	4	shoulder ring 26.1x34x1
11	2.1631.717.0	2	roll pin 8 x 40
12	0.086.1231.0/10	1	box
13	2.3130.001.1	4	plug 1/8" gas
14	2.0139.028.2	4	screw m 12
15	2.1579.628.0	3	spacer 16.5x26x0.1
15	2.1589.048.0	1	shoulder ring 16.5x26x0.3
16	2.1579.629.0	4	spacer 12.5x26x0.1
16	2.1589.049.0	2	shoulder ring 12.5x26x0.3
17	2.1579.626.0	2	spacer 13.2x16x11
18	2.1589.139.0	1	shoulder ring mm 0.3
19	2.1589.140.0	3	shoulder ring mm 0.1
20	2.1699.191.0	1	bush 7x10x16
21	0.065.1234.0/10	2	shaft
22	2.3130.001.1	1	plug 1/8" gas

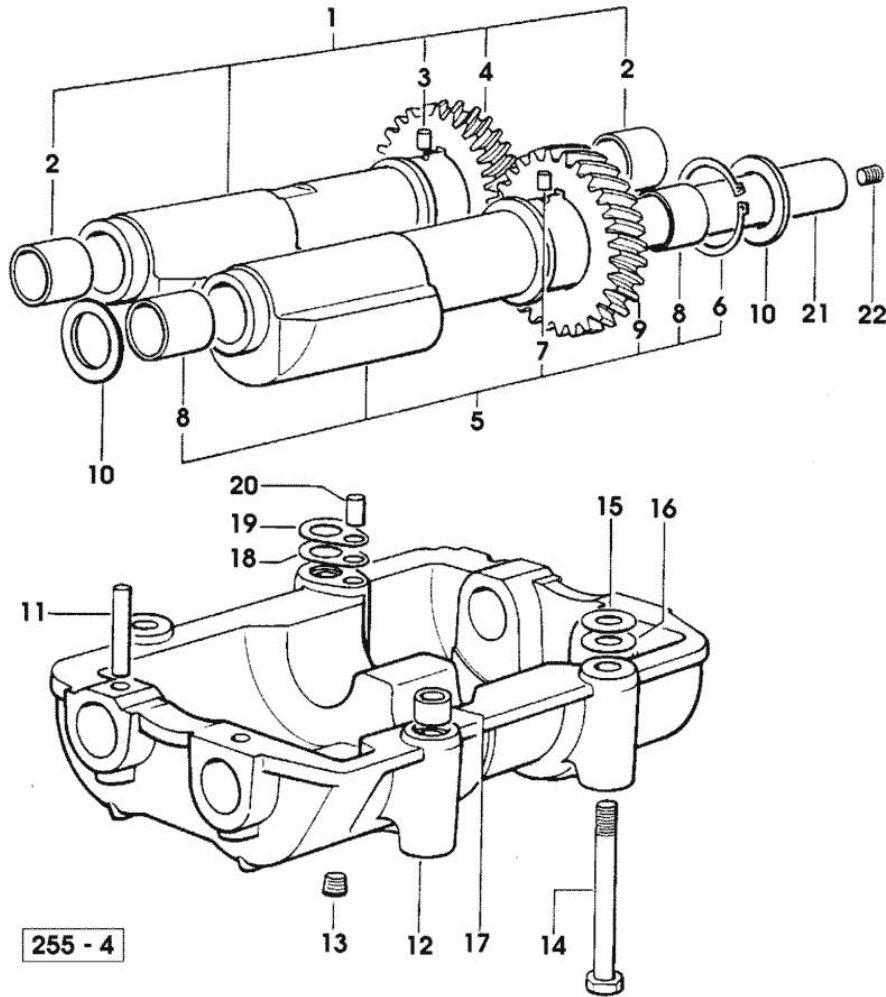

Section: ENGINE

CAMSHAFT

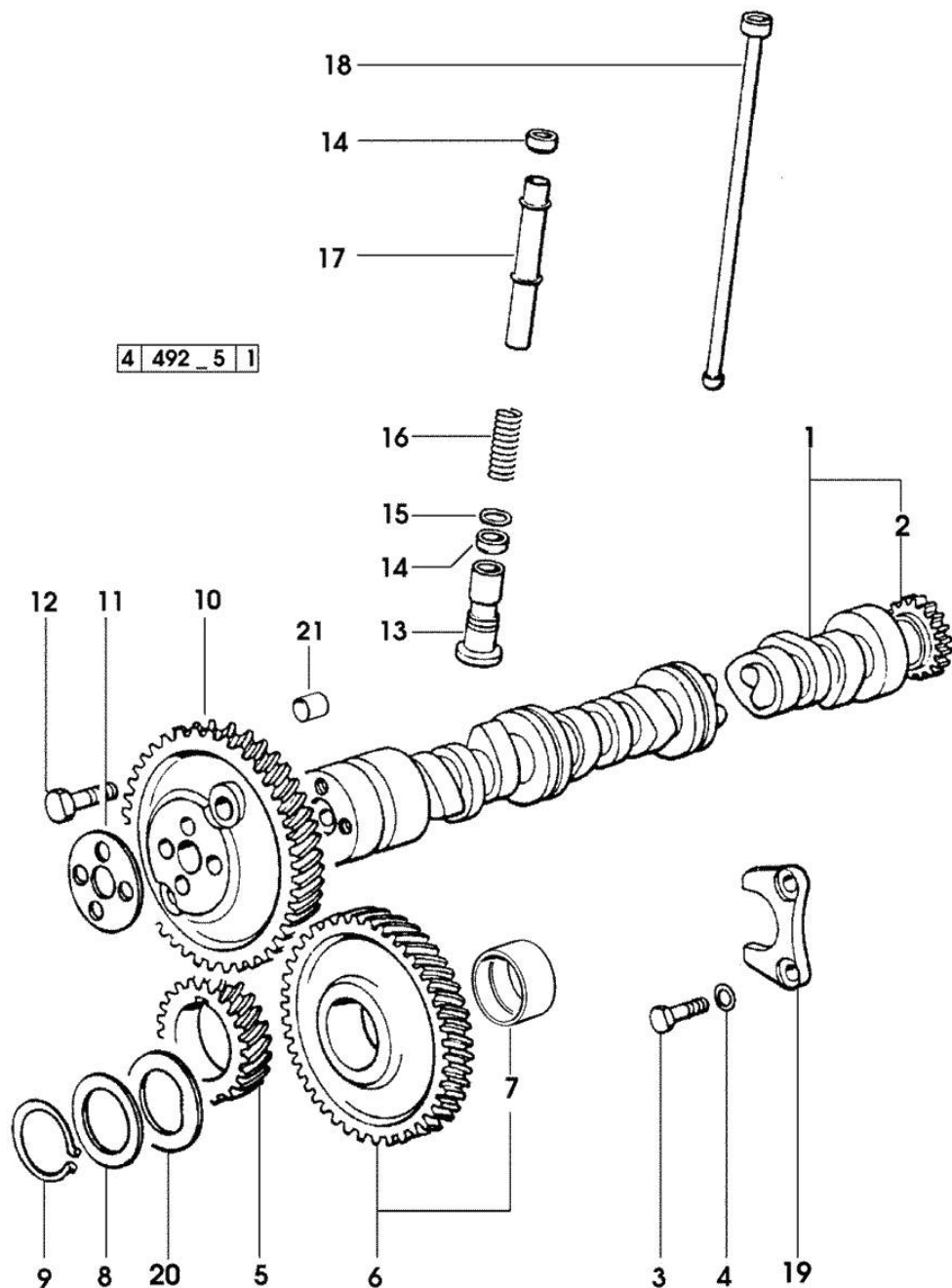

Fig.	P/n	QTY	Name
------	-----	-----	------

Notes:
[SILVER 100.4]

1	0.007.1712.3/10	1	camshaft - EXPORT U.S.A.
1	0.066.1310.3/40	1	camshaft
2	0.065.1324.0/10	1	gear Z = 32
3	2.0312.206.2	2	screw m 8 p 1.25 x 20
4	2.1480.014.1	2	washer 8
5	0.065.1323.0/30	1	gear Z = 29
6	0.007.1177.3/10	1	gear z = 57 - WITH RED IDENTIFICATION STAMP
6	0.007.1178.3/10	1	gear z = 57 - WITH YELLOW IDENTIFICATION STAMP
6	0.007.1179.3/10	1	gear z = 57 - WITH GREEN IDENTIFICATION STAMP
7	2.1559.185.0/10	1	bushing
8	0.065.1352.0	1	shim
9	2.1410.016.1	1	circlip 40
10	0.065.1354.0/20	1	gear z=58
11	0.065.1350.0	1	small disc
12	2.0132.207.2	4	screw m 10 p.1 x 25
13	0.065.1330.0	8	tappets
14	2.1569.114.0/10	16	gasket 14x18.5x8
15	2.1599.437.0	8	shoulder ring
16	2.4019.300.1/10	8	spring 18.5x52x2
17	0.065.1332.0	8	sleeve
18	0.065.1331.2	8	rod
19	0.065.1353.0	1	small plate
20	0.065.1351.0	2	shoulder ring
21	2.1559.398.0	1	bushing 10.5x13x12

Section: ENGINE
CYLINDER HEAD

Fig.	P/n	QTY	Name
------	-----	-----	------

Notes:
[SILVER 100.4]

1	2.0399.130.2/10	4	screw m 8x36x44
2	2.1569.170.0/10	4	gasket 8.2 x 14
3	0.007.1139.0/10	4	small cap
4	0.065.1450.0/30	1	tappet gasket
5	2.1011.421.2	8	nut m 10 p.1.25
6	2.0432.163.7	8	stud bolt m 10 p.1.5 / p.1.25 x 45
7	0.066.1430.0/10	4	support
8	0.066.1432.3	8	rocker arm
9	2.1559.021.0/40	8	bushing 15x19x22
10	2.1410.055.1	8	circlip 19
11	2.1011.405.2	8	nut m 8 p.1
12	0.021.1434.0	8	screw
13	0.074.1423.0	16	conical valve cotter
14	0.066.1425.0	8	cup
15	2.4019.287.0	8	spring
16	0.007.1122.0/10	4	bush L = mm 6.4
17	2.0432.161.7	4	stud bolt m 10 p.1.5 / p.1.25 x 40
18	0.065.1443.0/20	16	screw
20	2.0432.007.2	8	stud bolt m 8 p.1.25 / p.1 x 30
21	0.085.1450.0		head gasket mm 0.5 -A-
21	0.085.1451.0		head gasket mm 0.7 -B-
21	0.085.1452.0		head gasket mm 1.0 -C-
21	0.085.1453.0		head gasket mm 0.8 -D-
22	0.010.6022.0	4	exhaust valve mm 39.1 / Ø mm 9 - X SILVER 90 - 100.4 -> (...) = B
22	0.066.1421.0	4	exhaust valve - X SILVER 80 - X SILVER 90 - 100.4 (...) <- = A
23	0.010.6016.0	4	inlet valve mm 43.63 / Ø mm 9 - X SILVER 80
23	0.010.6017.0	4	inlet valve mm 43.63 / Ø mm 9 - X SILVER 90 - 100.4 -> (...) = B
23	0.081.1420.0	4	inlet valve Ø mm 9 - X SILVER 90 - 100.4 (...) <- = A
24	0.007.1110.3/50	4	engine head - X SILVER 80 - X SILVER 90 - 100.4 (...) <- = A
24	0.007.1359.3/50	4	engine head - X SILVER 90 - 100.4 -> (...) = B
25	0.066.1427.0	4	valve seat
26	0.078.1426.0	4	valve seat

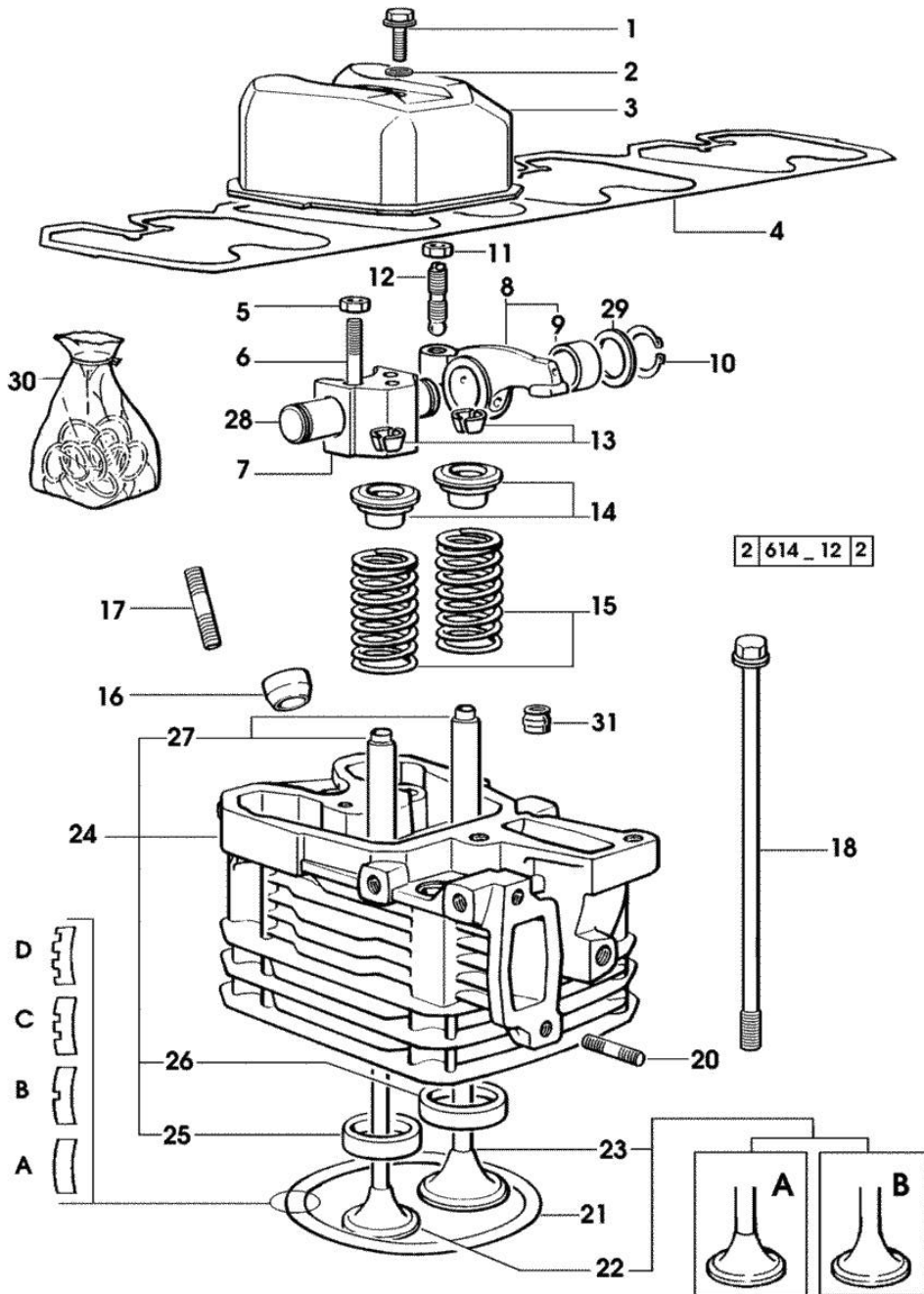

Section: ENGINE
CYLINDER HEAD

Fig.	P/n	QTY	Name
27	0.007.1779.0/10	8	valve guide
28	0.066.1431.0	4	pin
29	2.1599.432.0	8	shoulder ring
30	0.336.0057.6		gasket set - FOR 1 CYLINDER VALVE GRINDING AND PISTON RINGS REPLACEMENT
31	2.1519.117.0	8	special oil seal

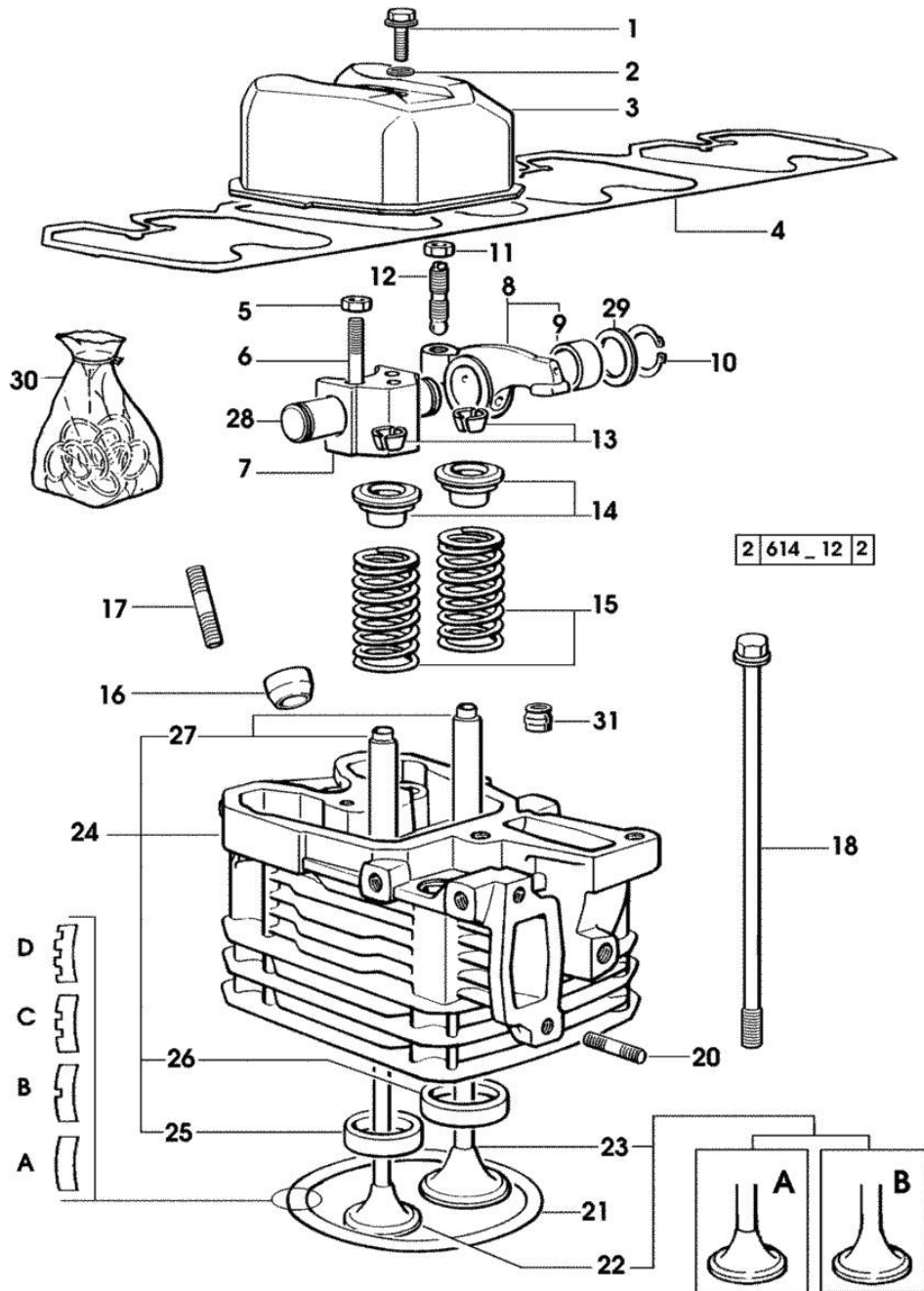

Section: ENGINE
LUBRICATION

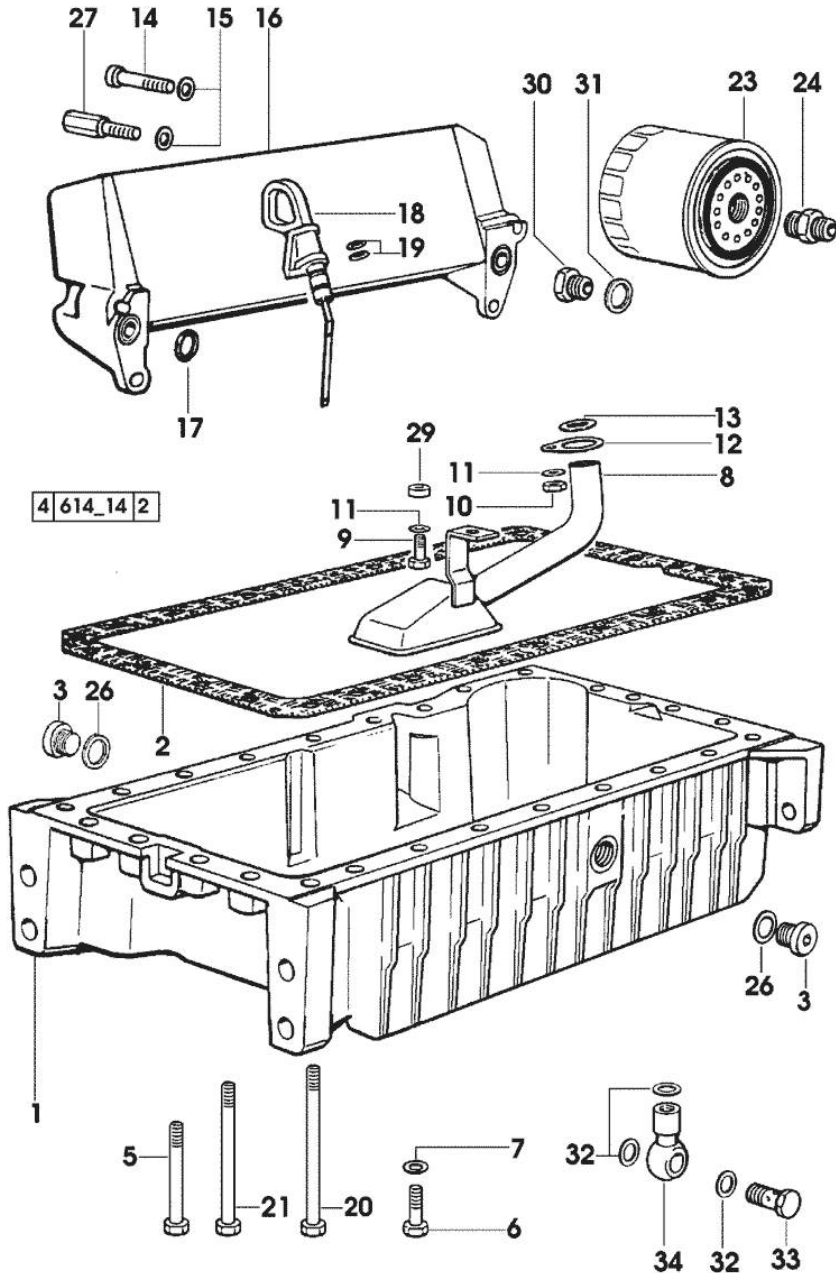

Fig.	P/n	QTY	Name
------	-----	-----	------

Notes:
[SILVER 100.4]

1	0.007.1277.0/40	1	oil sump
2	0.065.1550.0/10	1	gasket
3	2.3199.001.2	2	plug 1/2" gas
5	2.0112.226.2	4	screw m 8 p.1.25 x 85
6	2.0112.215.2	17	screw m 8 p.1.25 x 40
7	2.1470.004.2	26	lock washer 8
8	0.065.1531.3/20	1	tube
9	2.0112.209.2	1	screw m 8 p 1.25 x 25
10	2.1011.105.2	1	nut m 8 p.1.25
11	2.1470.004.2	2	lock washer 8
12	0.065.1538.0	1	flange
13	2.1539.040.0	1	special oil seal 21.82 x 3.53
14	2.0112.219.2	2	screw m 8 p.1.25x55
15	2.1480.014.1	4	washer 8
16	0.007.1679.3	1	radiator
17	2.1539.048.0	2	special oil seal 20.35x1.78
18	0.086.1513.2/20	1	dipstick
19	2.1539.065.0	2	special oil seal 8.73 x 1.78
20	2.0112.239.2	2	screw m 8 p.1.25 x 150
21	2.0112.235.2	3	screw m 8 p.1.25 x 130
23	0.044.1567.0	1	oil filter element - X SILVER 80
23	2.4419.340.0	1	oil filter element - X SILVER 90 - 100.4
24	2.3339.307.0	1	pipe fitting m 22 p.1.5-3/4"
26	2.1560.054.0	2	gasket 21 x 26
27	2.0399.200.2	2	screw
29	2.1579.766.2	1	spacer 8.5x16x10
30	2.3339.353.2/20	1	pipe fitting 12 p.1.5-18 p.1.5 - X SILVER 80
31	2.1560.014.0	1	washer 18.2 x 24 - X SILVER 80
32	2.1560.008.0	3	gasket 12.2 x 18 - X SILVER 80
33	2.3335.052.2	1	pipe union m 12 p.1.5 - X SILVER 80
34	2.3249.014.2	1	pipe fitting m 12 p.1.5 - X SILVER 80

Section: ENGINE
LUBRICATION

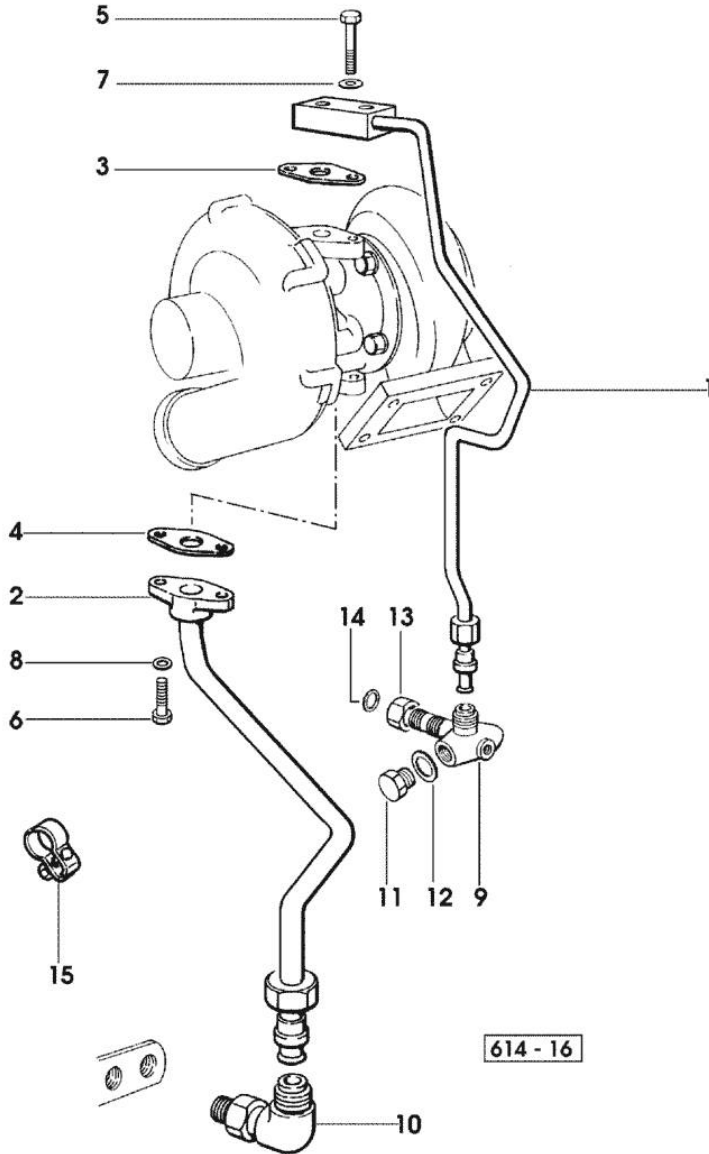

Fig.	P/n	QTY	Name
------	-----	-----	------

Notes:
 [SILVER 100.4]

1	0.008.9090.3/10	1	tube
2	0.008.9091.3/20	1	tube
3	0.052.1557.0	1	gasket
4	0.052.1558.0/10	1	gasket
5	2.0112.215.2	2	screw m 8 p.1.25 x 40
6	2.0112.207.2	2	screw m 8 p 1.25 x 20
7	2.1470.004.2	2	lock washer 8
8	2.1470.004.2	2	lock washer 8
9	2.3339.673.0/10	1	pipe fitting
			* (...) <=
			- N.1 2.1019.129.2/10 - 2.1530.038.0
10	2.3264.021.2	1	pipe fitting m 22 p.1.5 - 1" 1/16
11	2.3110.403.1	1	plug m 14 p.1.5x12
12	2.1560.010.0	1	gasket 14.2 x 20
13	2.1011.510.2	1	nut m 18 p.1.5
			(...) <=
13	2.1019.129.2/10	1	nut m 18 p.1.5x12
			=> (...)
14	2.1530.038.0	1	oil seal 15.54x2.62
15	0.007.1317.4	1	bracket



Suggest:

For more complete manuals. Please go to the home page.

<https://www.ebooklibonline.com>

If the above button click is invalid. Please download this document first, and then click the above link to download the complete manual.

Thank you so much for reading

Section: ENGINE
LUBRICATION

Fig.	P/n	QTY	Name
------	-----	-----	------

Notes:
[SILVER 100.4]

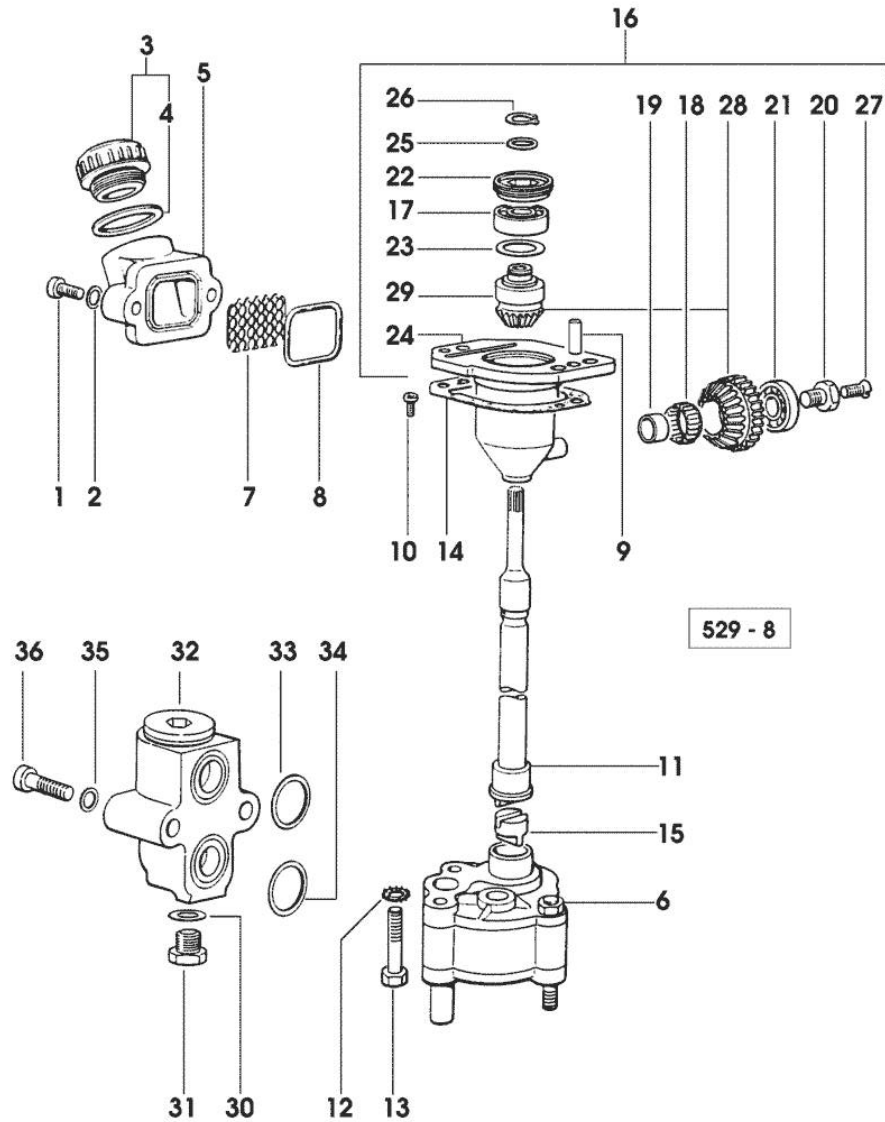

1	2.0312.206.2	2	screw m 8 p 1.25 x 20
2	2.1480.014.1	2	washer 8
3	0.041.1135.4	1	plug 1" gas
4	2.1569.072.0	1	gasket 32 x 39.5 x 2
5	0.065.1565.0/10	1	pipe union
6	0.010.5441.4/10	1	oil pump
7	0.065.1567.0/10	1	filter
8	2.1539.042.0	1	special oil seal 47.35x1.78
9	2.1651.711.0	2	pin 8 x 14
10	2.0169.005.2	2	screw m 6 p.1 x 12
11	0.065.1569.0/40	1	shaft
12	2.1470.006.2	2	lock washer 10
13	2.0112.324.2	2	screw m 10 p.1.5x75
14	0.065.1560.0/20	2	gasket
15	0.065.1562.0/10	1	joint
16	0.075.1551.4/20	1	support
17	2.2020.001.0	1	ball bearing 15 x 32 x 8.00
18	2.2725.016.0	1	roller cage 15 x 21 x 12
19	2.2680.020.0	1	ring 12 x 15 x 12
20	2.0399.128.2/10	1	screw m 8 p.1 x 8
21	2.2030.002.0	1	ball bearing 12 x 28 x 8
22	2.1219.025.2/10	1	ring nut m 36 p.1.5
23	2.1589.148.0	1	shoulder ring 28.2 x 31.8 x 0.5
23	2.1589.150.0	2	shoulder ring 28.2 x 31.8 x 0.1
23	2.1589.151.0	2	shoulder ring 28.2 x 31.8 x 0.15
24	0.075.1551.3/30	1	support
25	2.1589.146.0	2	shoulder ring 15.2 x 19 x 0.15
25	2.1589.147.0	2	shoulder ring 15.2 x 19 x 0.10
25	2.1589.153.0	1	shoulder ring 15.2 x 19 x 1.00
26	2.1410.057.1	1	circlip 15
27	2.0342.007.2	1	screw m 4 p.0.7x25
28	0.065.1558.6/10	1	bevel drive
29	0.065.1559.0	1	bush
30	2.1560.010.0	1	gasket 14.2 x 20
31	2.3110.403.1	1	plug m 14 p.1.5x12
32	0.065.1581.4/20	1	valve
33	2.1539.048.0	1	special oil seal 20.35x1.78
34	2.1539.072.0	1	special oil seal 23.52 x 1.78
35	2.1480.014.1	2	washer 8
36	2.0312.215.1	2	screw m 8 p.1.25 x 45

Section: ENGINE
LUBRICATION

Fig.	P/n	QTY	Name
------	-----	-----	------

Notes:
[SILVER 100.4]

1	0.009.7169.2/20	1	oil cooler
2	0.007.1842.3/50	1	tube
3	0.007.1843.3/50	1	tube
4	0.007.7894.0	1	plate
5	2.3261.010.2	2	pipe fitting m 18 p.1.5 - 7/8" 14
6	2.1539.072.0	1	special oil seal 23.52 x 1.78
7	2.1539.048.0	1	special oil seal 20.35x1.78
8	2.0312.221.2	2	screw m 8 p.1.25x75
9	2.1560.014.0	2	washer 18.2 x 24
10	2.3339.697.2	2	pipe fitting m 20x2x20x27
11	2.3359.021.0	2	nosepiece
12	2.0112.207.2	2	screw m 8 p 1.25 x 20
13	2.1470.004.2	2	lock washer 8

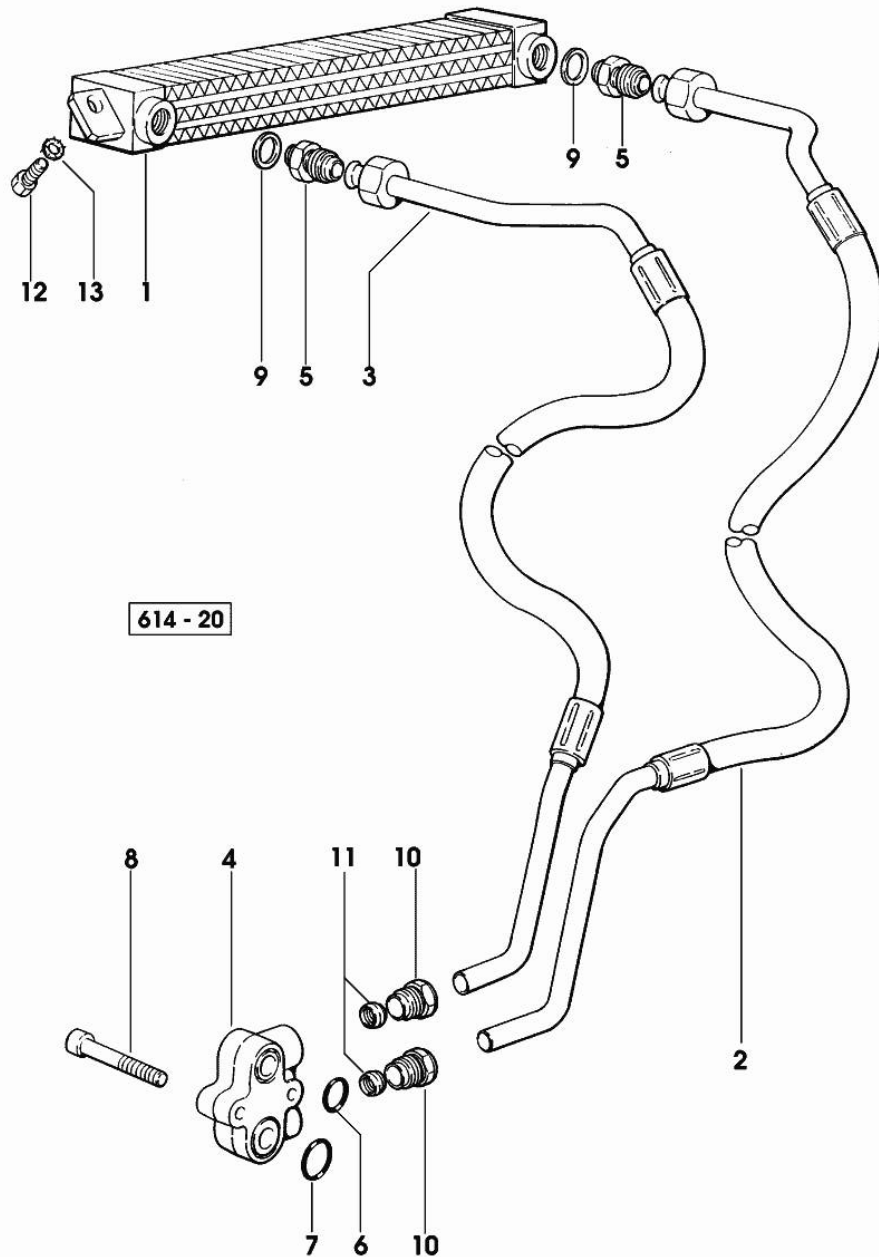

<https://www.ebooklibonline.com>

Hello dear friend!

Thank you very much for reading.

Enter the link into your browser.

The full manual is available for immediate download.

<https://www.ebooklibonline.com>