

Section: ENGINE
CRANKCASE

9_33211_00_0_A

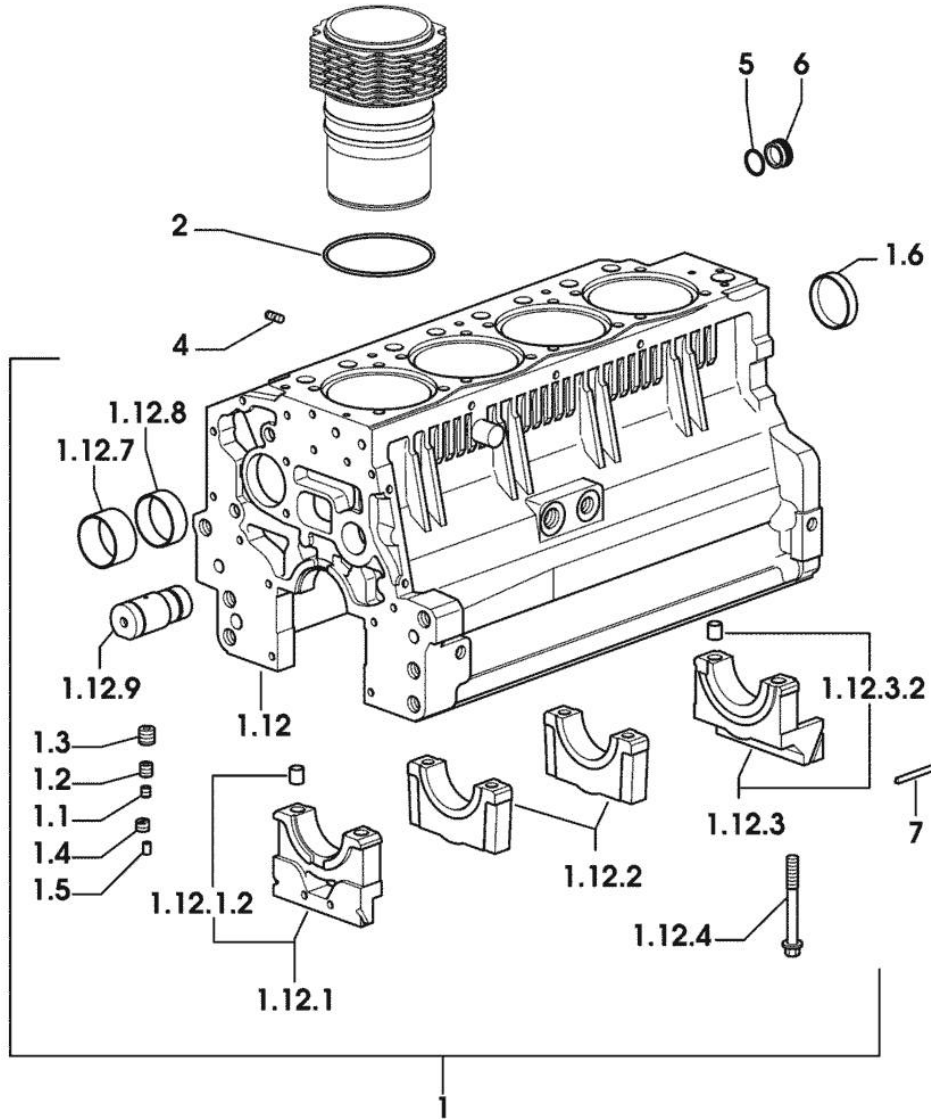

Fig.	P/n	QTY	Name
------	-----	-----	------

Notes:
[ROCK 70 M]

1	0.007.1140.6/10	1	crankcase
1.1	2.3130.001.1	11	plug 1/8" gas
1.2	2.3130.002.1	2	plug 1/4" gas
1.3	2.3130.003.1	7	plug 3/8" gas
1.4	2.1324.011.0	1	plug
1.5	2.3199.092.0	4	plug 8 x 12
1.6	2.3179.012.0	1	plug 60
1.12	0.000.0000.1		cannot be supplied
1.12.1	0.065.1112.7	1	support
1.12.1.2	2.1699.165.0	1	bush 12.3x15x16
1.12.2	0.065.1114.0/10	3	support
1.12.3	0.065.1116.3	1	support
1.12.3.2	2.1699.165.0	1	bush 12.3x15x16
1.12.4	0.065.1117.0	10	screw m 12 x 100
1.12.7	0.065.1141.0	1	special bushing 59X55X30
1.12.8	0.065.1140.0	4	special bushing 59X55X20
1.12.9	0.066.1151.0	1	pin
2	2.1539.130.0/10	4	special oil seal 117.07x3.53
4	2.0432.003.7	12	stud bolt m 8 p.1.25 / p.1 x 20
5	2.1532.072.0	1	oil seal 26.70x1.78
6	2.3199.405.2	1	plug m 28 p.1.5
7	0.066.1152.0/10	4	gasket

Fig.	P/n	QTY	Name
------	-----	-----	------

Notes:
 [ROCK 70 M]

1	0.007.1262.3/50	1	guard
2	0.007.1271.0/10	1	small column m 8 p.1.25 / L = mm 60
3	0.007.1272.0/10	2	small column m 8 p.1.25 / L = mm 50
5	2.1310.004.2	3	flat washer 8.4x17
7	2.0112.203.2	3	screw m 8 p.1.25 x 12

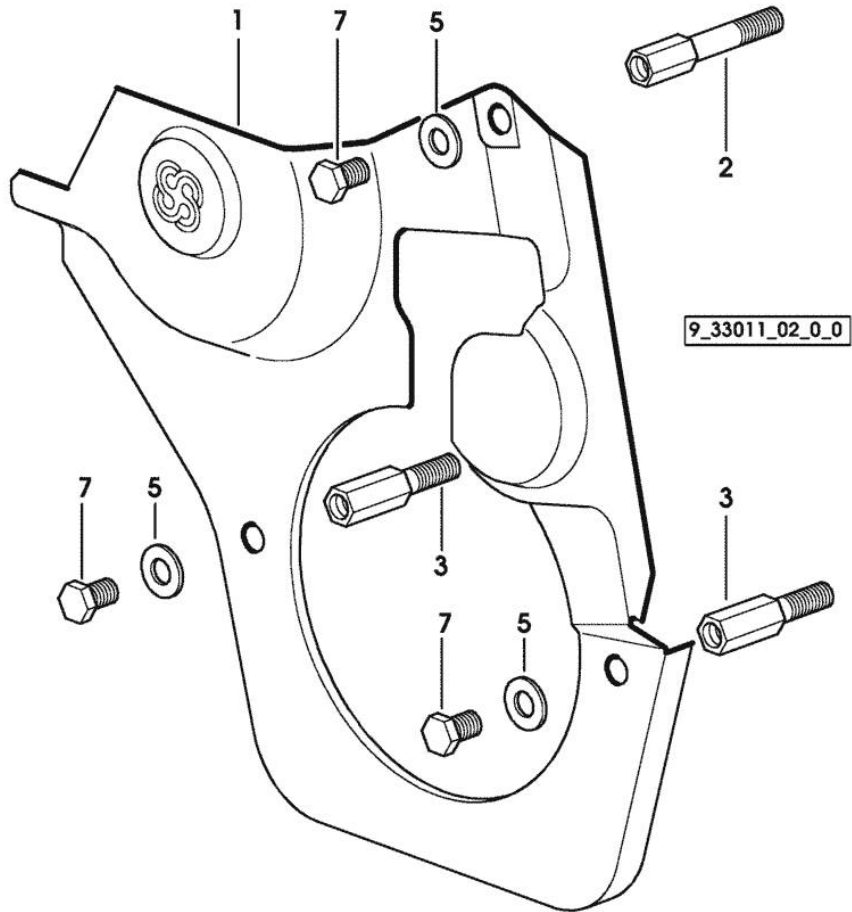

TIMING CASE

9_33211_00_0_B

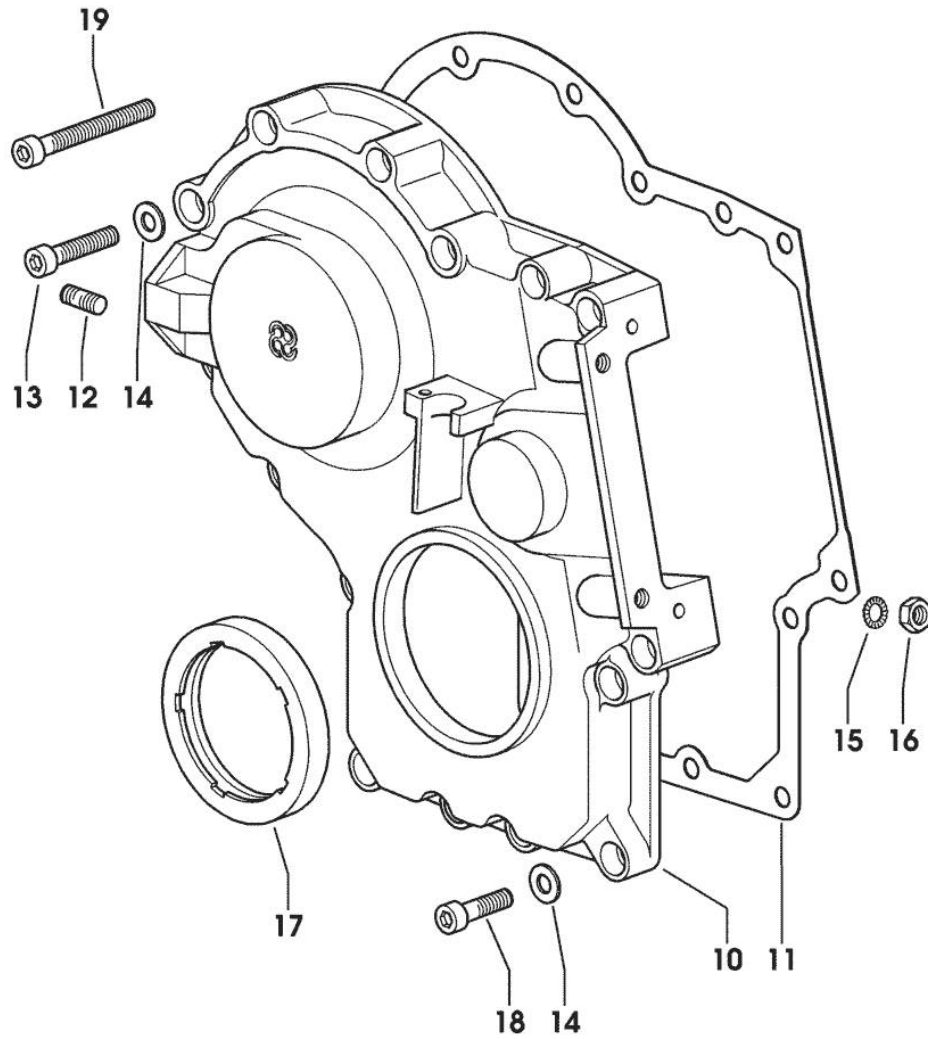

Notes:
[ROCK 70 M]

Fig.	P/n	QTY	Name
10	0.013.4981.0	1	guard -> 1156 X ROCK 70
10	0.065.1132.0/50	1	guard 1155 <- X ROCK 70
11	0.065.1150.0/30	1	gasket
12	2.0432.003.7	2	stud bolt m 8 p.1.25 / p.1 x 20
13	2.0312.214.2	3	screw m 8 p.1.25 x 40
14	2.1480.014.1	15	washer 8
15	2.1470.004.2	4	lock washer 8
16	2.1011.405.2	2	nut m 8 p.1
17	2.1529.141.0	1	special oil seal
18	2.0312.208.2	8	screw m 8 p.1.25 x 25
19	2.0312.219.2	4	screw m 8 p.1.25x65

<https://www.ebooklibonline.com>

Hello dear friend!

Thank you very much for reading.

Enter the link into your browser.

The full manual is available for immediate download.

<https://www.ebooklibonline.com>

Section: ENGINE
CRANKCASE

Fig.	P/n	QTY	Name
------	-----	-----	------

Notes:
 [ROCK 70 M]

6	2.0439.250.7	1	stud bolt m 12 / m 10 x 30
7	0.011.9294.0/10	1	bush
30	2.0112.511.2	8	screw m 14 p.2 x 30
31	2.1651.912.0	2	cylindrical plug 12x28
32	2.1651.917.0	1	cylindrical plug 12x40
33	2.0432.257.7	1	stud bolt m 12 p.1.75 - 1.25 x 30
34	0.007.9745.0/10	1	flange

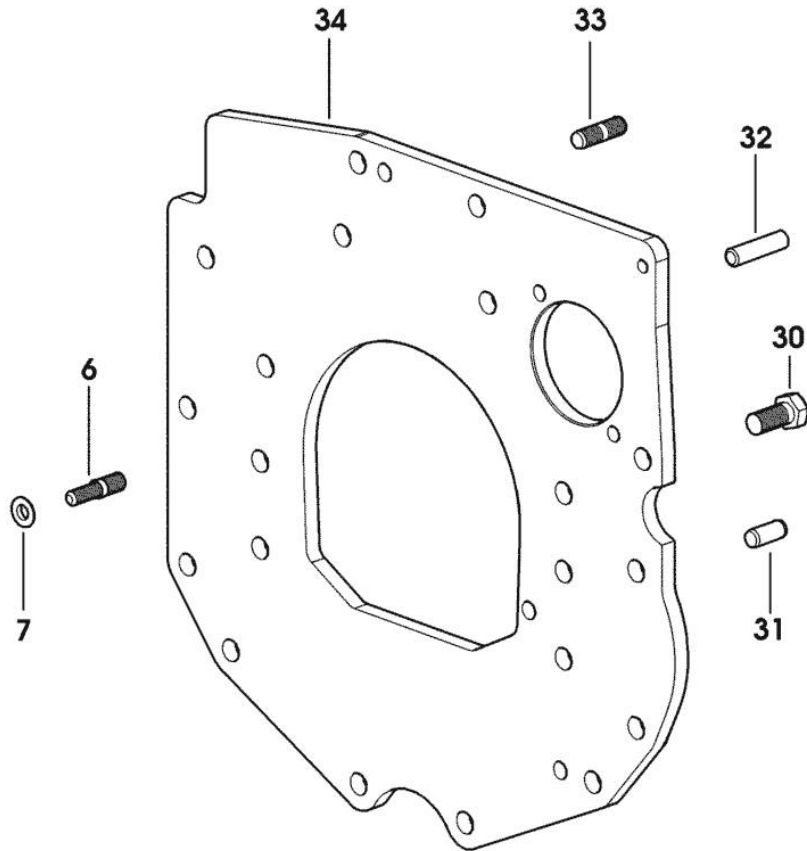

9_33311_02_0_0

Section: ENGINE

SIDE PLUG FOR CYLINDER BLOCK

Fig.	P/n	QTY	Name
------	-----	-----	------

Notes:

[ROCK 70 M]

22	2.1560.017.0	1	gasket 22.2 x 27
23	2.3120.002.4	1	plug m 22 x 1.5

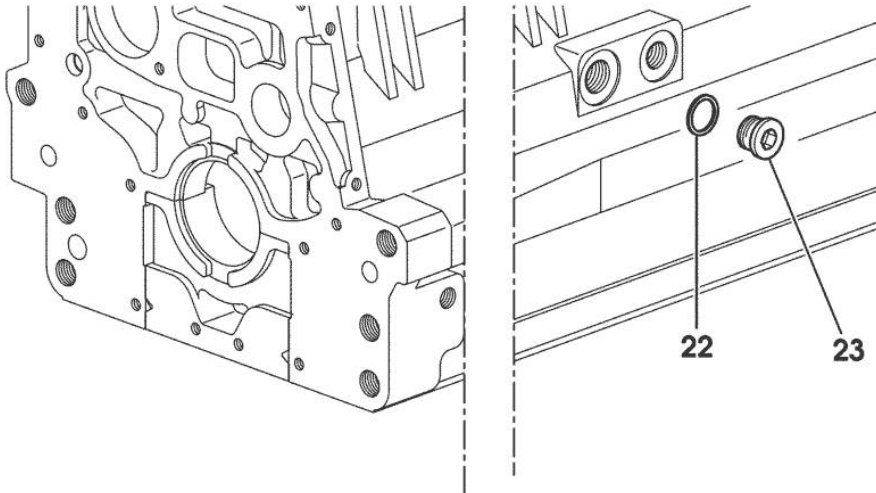

9_33211_07_0_0

Section: ENGINE

CRANKSHAFT

9_33212_00_0_0

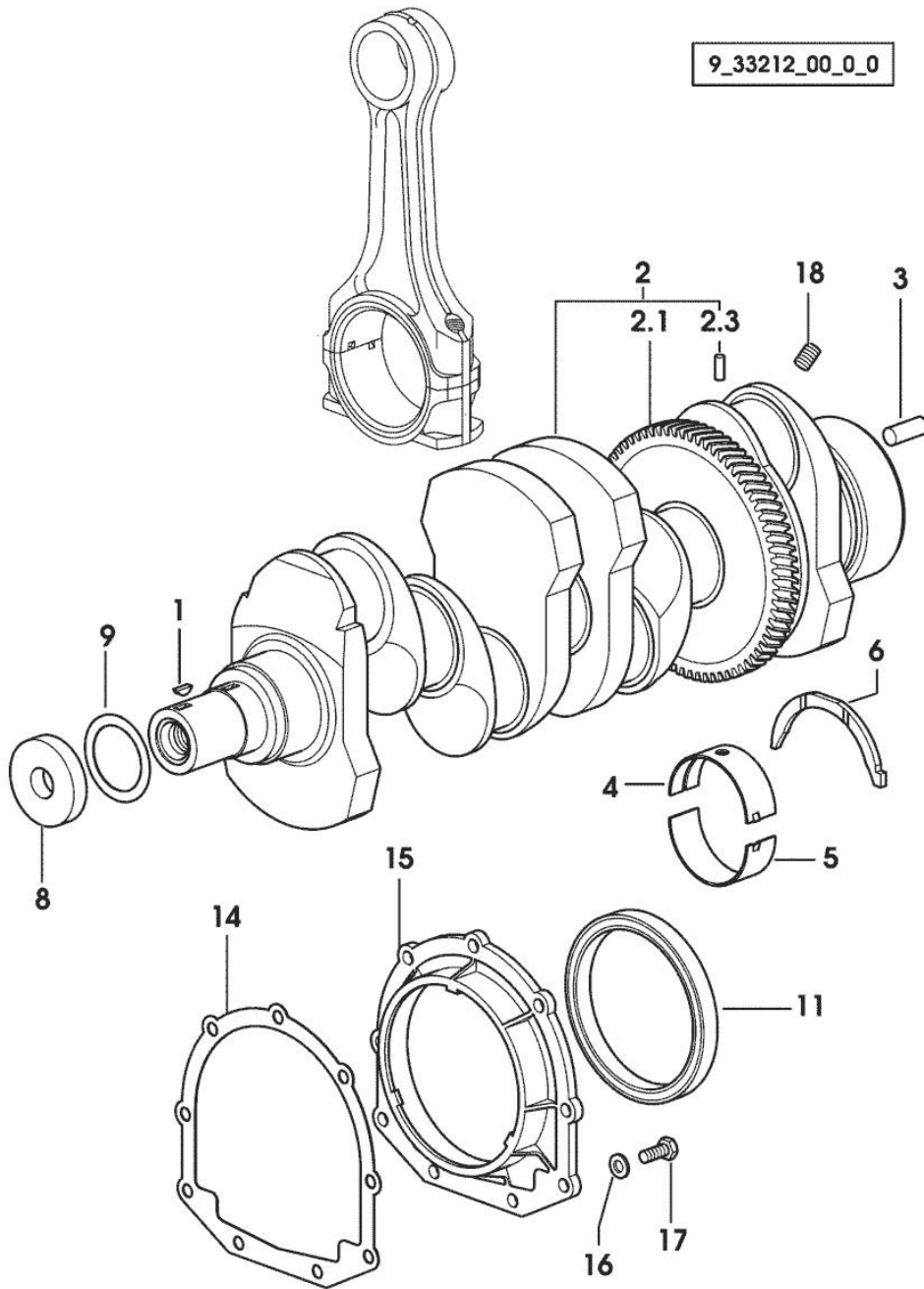

Fig.	P/n	QTY	Name
------	-----	-----	------

Notes:
[ROCK 70 M]

1	2.1720.006.0	1	key 4x6.5
2	0.086.1210.3/30	1	crankshaft
2.1	0.065.1211.0/10	1	crown wheel
2.3	2.1630.608.0	1	pin 6x16
3	2.1651.915.0	1	pin 12x35
4	0.065.1215.0	5	main half bushing STANDARD
4	0.065.1215.7		main half bushing - mm 0.25
4	0.065.1215.8		main half bushing - mm 0.50
5	0.065.1216.0	5	main half bushing
5	0.065.1216.7		main half bushing - mm 0.25
5	0.065.1216.8		main half bushing - mm 0.50
6	0.065.1218.0	4	shim STANDARD
6	0.065.1218.7		shim + mm 0.10
6	0.065.1218.8		shim + mm 0.15
8	2.1599.524.7	1	washer 21x60x12
9	2.1589.189.0	2	shoulder ring mm 1.00
11	2.1529.073.0	1	special oil seal 110x130x13
14	0.065.1254.0/20	1	gasket
15	0.007.1711.0/10	1	cover
16	2.1475.002.2	9	conical washer 8
17	2.0112.207.2	9	screw m 8 p 1.25 x 20
18	2.3130.001.1	4	plug 1/8" gas

CYLINDER - PISTON - CONNECTING ROD

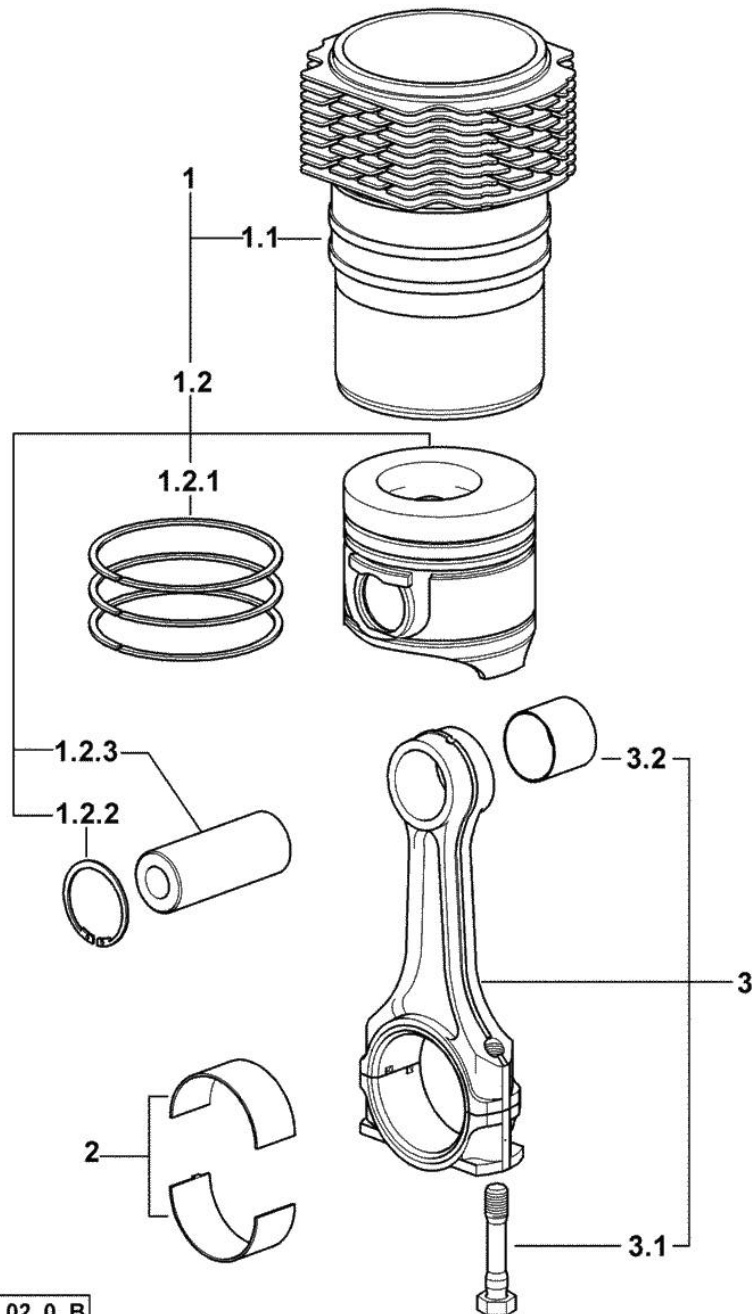

Fig.	P/n	QTY	Name
------	-----	-----	------

Notes:

71504 <= X ROCK 70 [ROCK 70 M]

1	0.336.0065.A	4	cyl. piston assembly "A" - CLASS A
1	0.336.0065.B	4	cyl. piston assembly "B" - CLASS B
1.1	0.A13.0355.0	1	engine cylinder "A" - CLASS A
1.1	0.B13.0355.0	1	engine cylinder "B" - CLASS B
1.2	0.086.0060.A	1	complete piston "A" - CLASS A
1.2	0.086.0060.B	1	complete piston "B" - CLASS B
1.2.1	0.086.0052.6/10	1	piston ring set
1.2.2	2.1411.014.1	2	circlip 35
1.2.3	0.078.1236.0	1	piston pin Ø 18 / Ø 35 / L = mm 86
2	0.065.1225.0	8	con.rod half bushing STANDARD - A = 28.75 -> 29.00
2	0.065.1225.7	8	con.rod half bushing - mm 0.25
2	0.065.1225.8	8	con.rod half bushing - mm 0.50
3	0.078.1220.3/30	4	engine connecting rod
3.1	2.0399.213.0	2	screw m 12 p.1.25x61.5
3.2	2.1559.114.0/10	1	special bushing

CYLINDER - PISTON - CONNECTING ROD

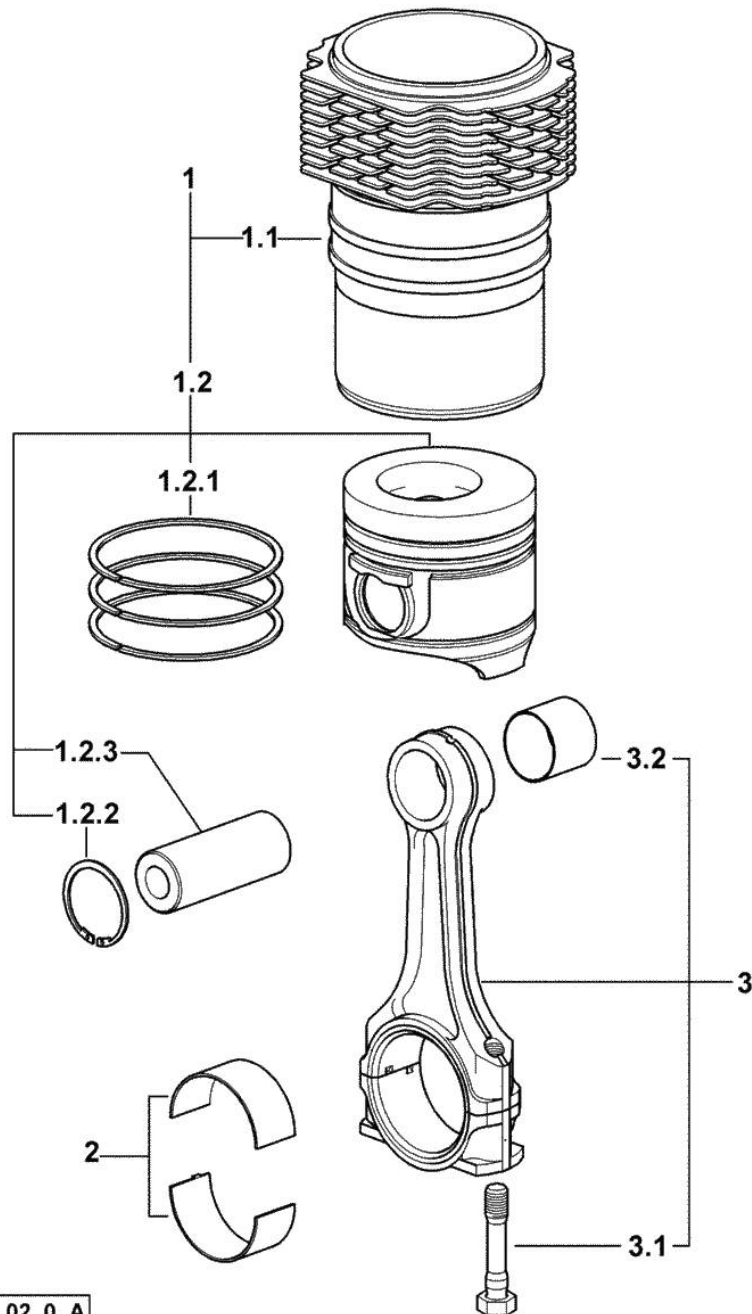

Fig.	P/n	QTY	Name
------	-----	-----	------

Notes:

=> 71505 X ROCK 70 [ROCK 70 M]

1	0.379.0065.A	4	cyl. piston assembly "A" - CLASS A
1	0.379.0065.B	4	cyl. piston assembly "B" - CLASS B
1.1	0.A13.0355.0	1	engine cylinder "A" - CLASS A
1.1	0.B13.0355.0	1	engine cylinder "B" - CLASS B
1.2	0.379.0060.A	1	complete piston "A" - CLASS A
1.2	0.379.0060.B	1	complete piston "B" - CLASS B
1.2.1	0.086.0052.6/10	1	piston ring set
1.2.2	2.1411.014.1	2	circlip 35
1.2.3	0.078.1236.0	1	piston pin Ø 18 / Ø 35 / L = mm 86
2	0.065.1225.0	8	con.rod half bushing STANDARD - A = 28.75 -> 29.00
2	0.065.1225.7	8	con.rod half bushing - mm 0.25
2	0.065.1225.8	8	con.rod half bushing - mm 0.50
3	0.078.1220.3/30	4	engine connecting rod
3.1	2.0399.213.0	2	screw m 12 p.1.25x61.5
3.2	2.1559.114.0/10	1	special bushing

Section: ENGINE

ENGINE FLYWHEEL

Fig.	P/n	QTY	Name
------	-----	-----	------

Notes:
[ROCK 70 M]

1	0.007.9562.3/10	1	flywheel
1.2	0.065.1242.0	1	crown wheel Z = 123
2	2.0119.174.0/10	6	screw m 12 p.1.25x45
3	2.2041.008.0	1	ball bearing 20x47x14

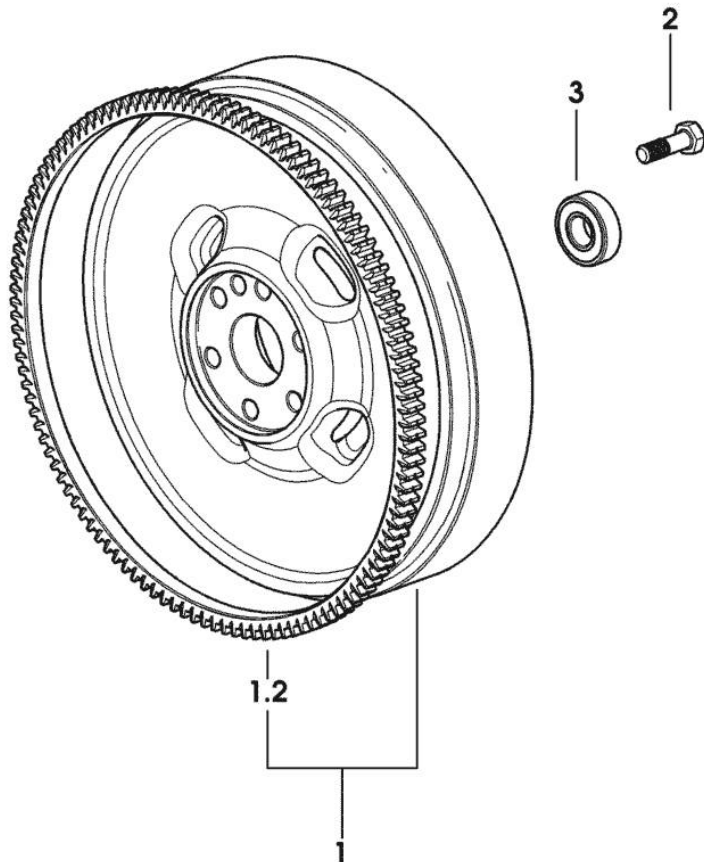

Section: ENGINE

CRANKSHAFT PULLEY

Fig.	P/n	QTY	Name
------	-----	-----	------

Notes:
[ROCK 70 M]

1	0.007.1330.0/40	1	pulley
2	2.1589.189.0	2	shoulder ring mm 1.00
3	0.085.1248.0/20	1	hub
4	2.0399.144.7/10	1	screw m 20 p.1.5x51
6	2.1720.006.0	1	key 4x6.5

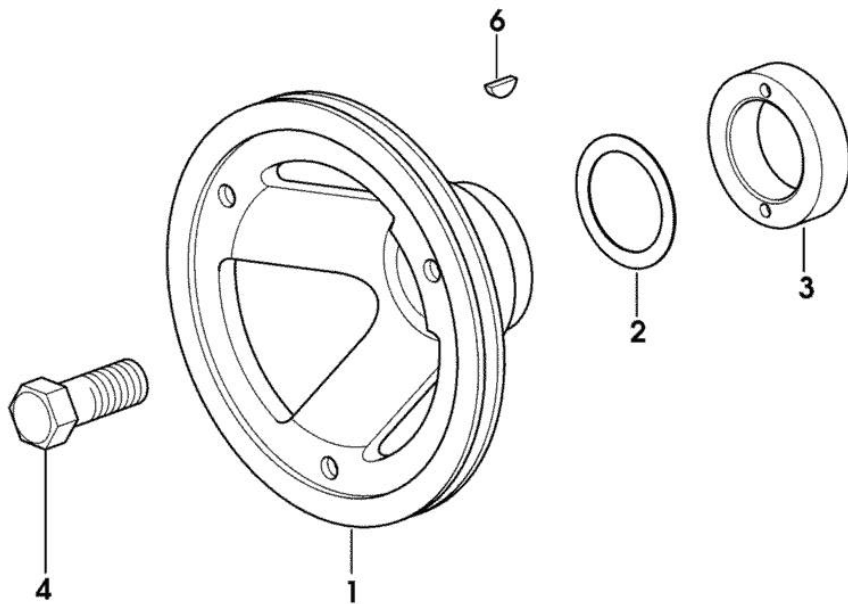

9_33012_02_0_0

Section: ENGINE
COUNTERWEIGHTS

Fig.	P/n	QTY	Name
------	-----	-----	------

Notes:
 [ROCK 70 M]

25	2.1589.139.0	1	shoulder ring mm 0.3
26	2.1589.140.0	3	shoulder ring mm 0.1
29	2.1579.628.0	3	spacer 16.5x26x0.1
33	2.1579.629.0	6	spacer 12.5x26x0.1
34	2.1589.048.0	1	shoulder ring 16.5x26x0.3
35	2.1589.049.0	1	shoulder ring 12.5x26x0.3
40	0.086.1233.3/30	1	mass sx/lh/li
40.2	2.1559.115.0	2	special bushing 26x30x30
40.3	0.000.0000.1		cannot be supplied
40.4	2.1651.302.0	1	roll pin 4x6
41	0.065.1233.3/30	1	mass dx/rh/re
41.2	2.1559.115.0	2	special bushing 26x30x30
41.3	0.000.0000.1		cannot be supplied
41.99	0.000.0000.1		cannot be supplied
41.99.4	2.1651.302.0	1	roll pin 4x6
41.99.5	2.1410.018.1	1	circlip 45
42	0.000.0000.1		cannot be supplied
42.1	0.086.1231.0/10	1	box
42.2	2.3130.001.1	4	plug 1/8" gas
43	2.1631.717.0	2	roll pin 8 x 40
44	2.1579.626.0	2	spacer 13.2x16x11
45	2.0139.028.2	4	screw m 12
46	2.1699.191.0	1	bush 7x10x16
47	0.000.0000.1		cannot be supplied
47.1	0.065.1234.0/10	1	shaft
47.2	2.3130.001.1	1	plug 1/8" gas
48	2.1589.185.0	4	shoulder ring 26.1x34x1

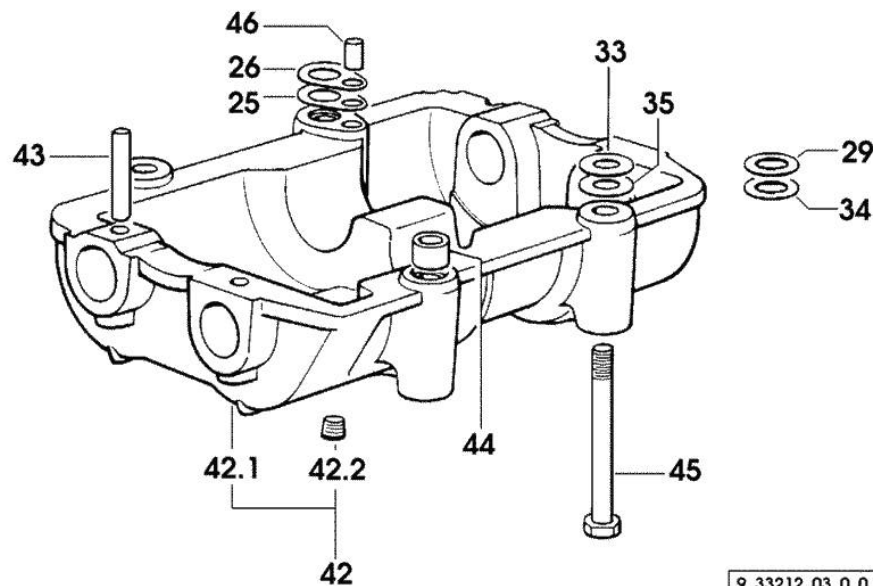
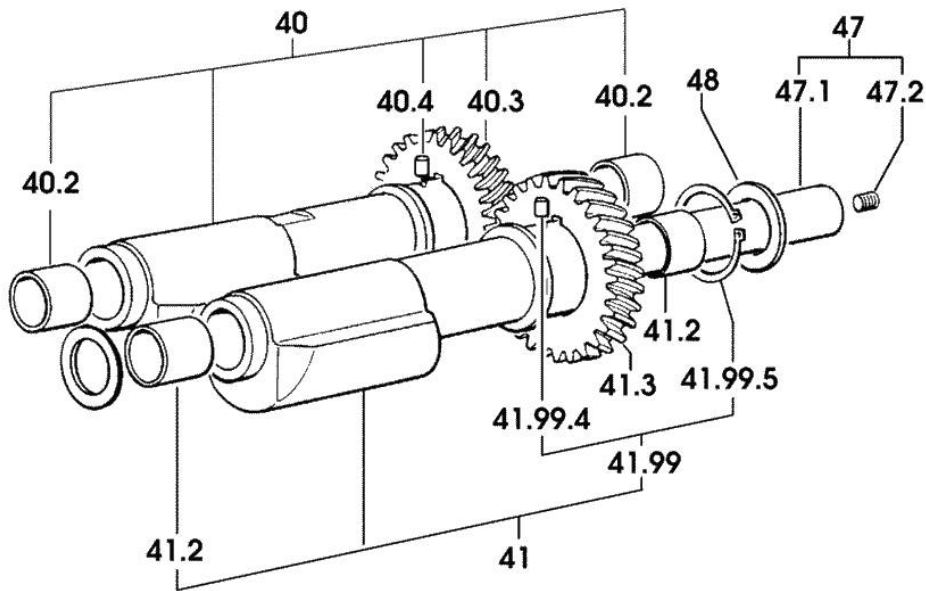

9_33212_03_0_0

Section: ENGINE

CAMSHAFT

Fig.	P/n	QTY	Name
------	-----	-----	------

Notes:

71504 <= X ROCK 70 [ROCK 70 M]

1	0.065.1331.2	8	rod
2	2.1569.114.0/10	16	gasket 14x18.5x8
3	0.065.1332.0	8	sleeve
4	2.4019.300.1/10	8	spring 18.5x52x2
5	2.1599.437.0	8	shoulder ring
6	0.065.1330.0	8	tappets
7	0.013.5017.0	1	gear z=58
8	2.0132.207.2	4	screw m 10 p.1 x 25
9	0.066.1310.3/40	1	camshaft
9.2	0.065.1324.0/10	1	gear Z = 32
10	0.065.1350.0	1	small disc
11	2.1410.016.1	1	circlip 40
12	0.065.1352.0	1	shim
13	0.065.1351.0	2	shoulder ring
14	0.065.1323.0/30	1	gear Z = 29
16	2.0312.205.2	2	screw
17	2.1480.014.1	2	washer 8
18	0.065.1353.0	1	small plate
19	0.007.1177.3/20		gear z = 57
			- WITH RED IDENTIFICATION STAMP
19.2	2.1559.185.0/10	1	bushing
20	0.007.1178.3/20		gear z = 57
			- WITH YELLOW IDENTIFICATION STAMP
20.2	2.1559.185.0/10	1	bushing
21	0.007.1179.3/20		gear z = 57
			- WITH GREEN IDENTIFICATION STAMP
21.2	2.1559.185.0/10	1	bushing
22	2.1559.398.0	1	bushing 10.5x13x12

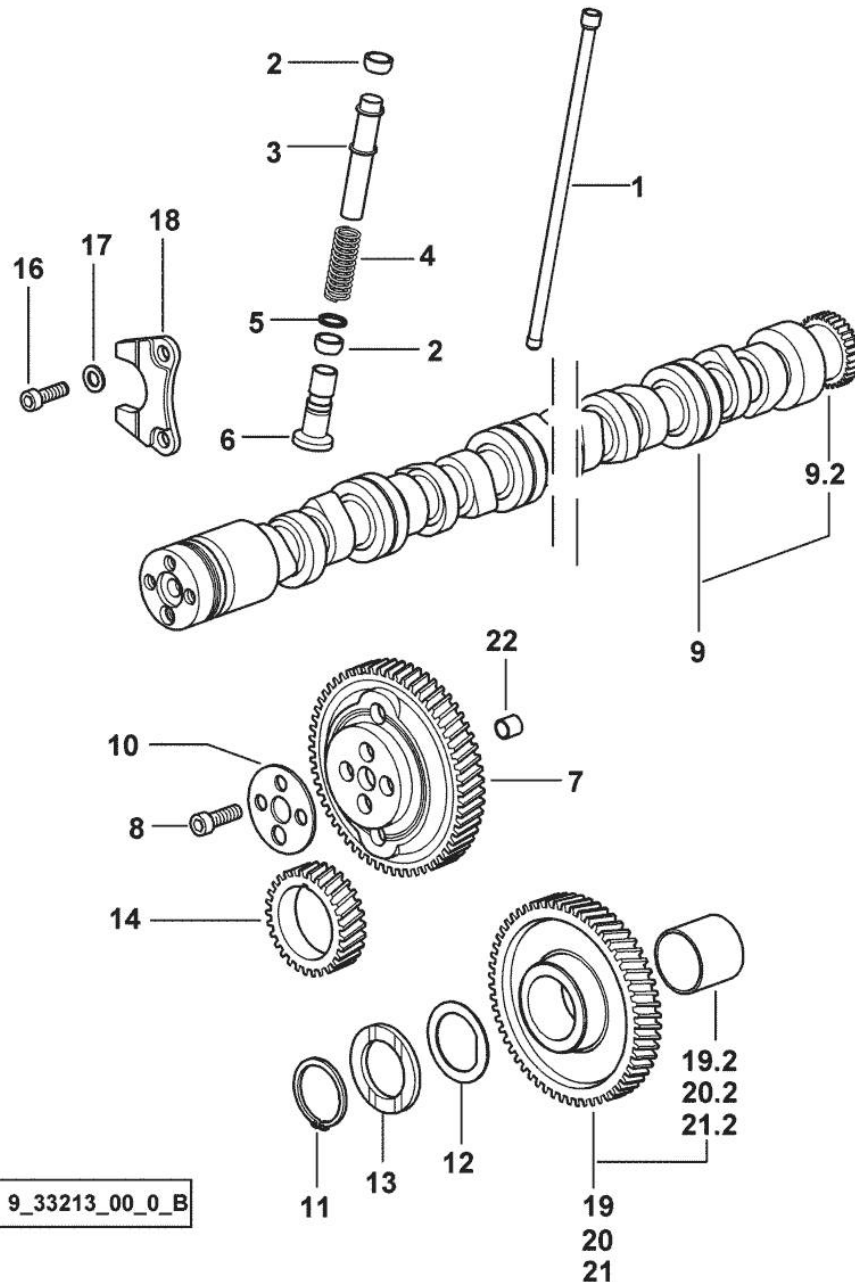



Suggest:

For more complete manuals. Please go to the home page.

<https://www.ebooklibonline.com>

If the above button click is invalid. Please download this document first, and then click the above link to download the complete manual.

Thank you so much for reading

Section: ENGINE

CAMSHAFT

Fig.	P/n	QTY	Name
------	-----	-----	------

Notes:

=> 71505 X ROCK 70 [ROCK 70 M]

1	0.065.1331.2	8	rod
2	2.1569.114.0/10	16	gasket 14x18.5x8
3	0.065.1332.0	8	sleeve
4	2.4019.300.1/10	8	spring 18.5x52x2
5	2.1599.437.0	8	shoulder ring
6	0.065.1330.0	8	tappets
7	0.013.5017.0	1	gear z=58
8	2.0132.207.2	4	screw m 10 p.1 x 25
9	0.007.1712.3/10	1	camshaft
9.2	0.065.1324.0/10	1	gear Z = 32
10	0.065.1350.0	1	small disc
11	2.1410.016.1	1	circlip 40
12	0.065.1352.0	1	shim
13	0.065.1351.0	2	shoulder ring
14	0.065.1323.0/30	1	gear Z = 29
16	2.0312.205.2	2	screw
17	2.1480.014.1	2	washer 8
18	0.065.1353.0	1	small plate
19	0.007.1177.3/20		gear z = 57
			- WITH RED IDENTIFICATION STAMP
19.2	2.1559.185.0/10	1	bushing
20	0.007.1178.3/20		gear z = 57
			- WITH YELLOW IDENTIFICATION STAMP
20.2	2.1559.185.0/10	1	bushing
21	0.007.1179.3/20		gear z = 57
			- WITH GREEN IDENTIFICATION STAMP
21.2	2.1559.185.0/10	1	bushing
22	2.1559.398.0	1	bushing 10.5x13x12

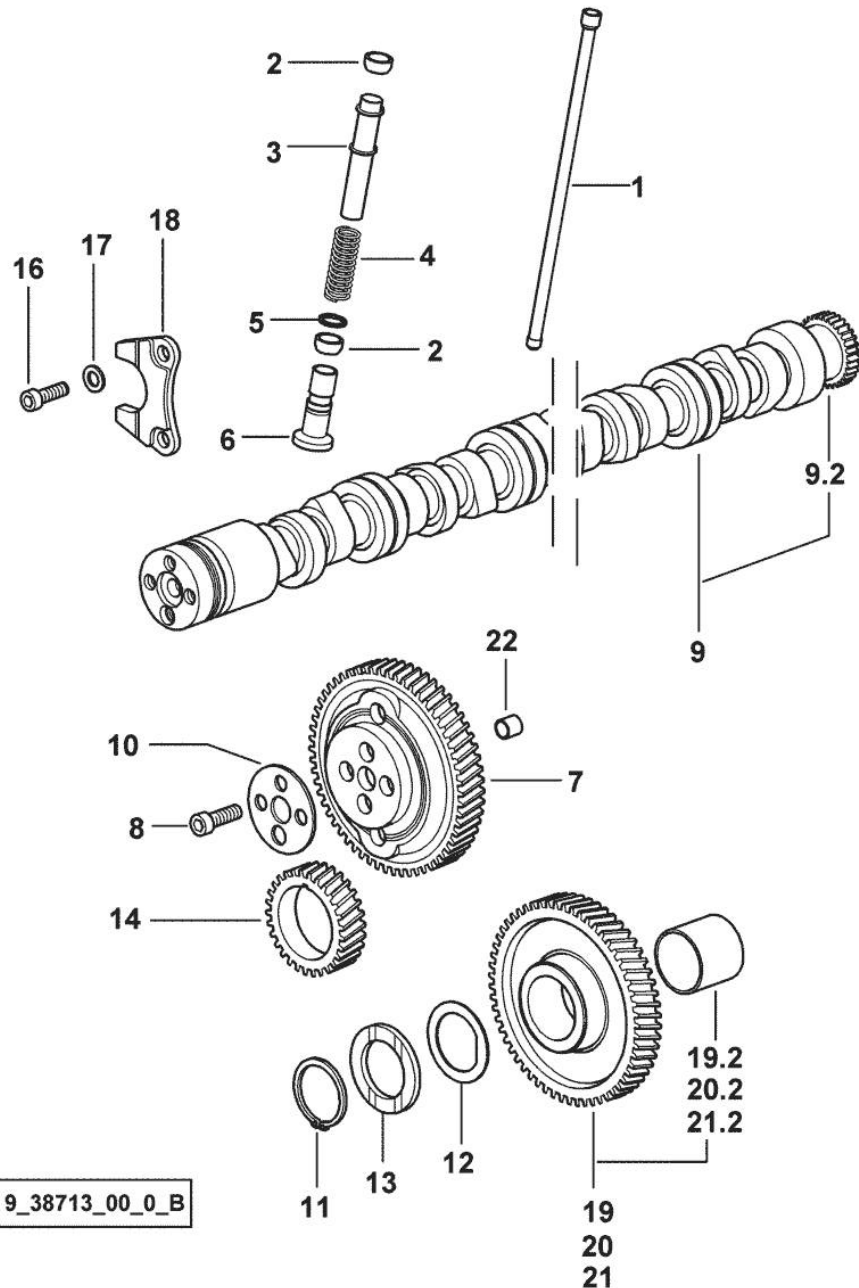

Section: ENGINE
CYLINDER HEAD

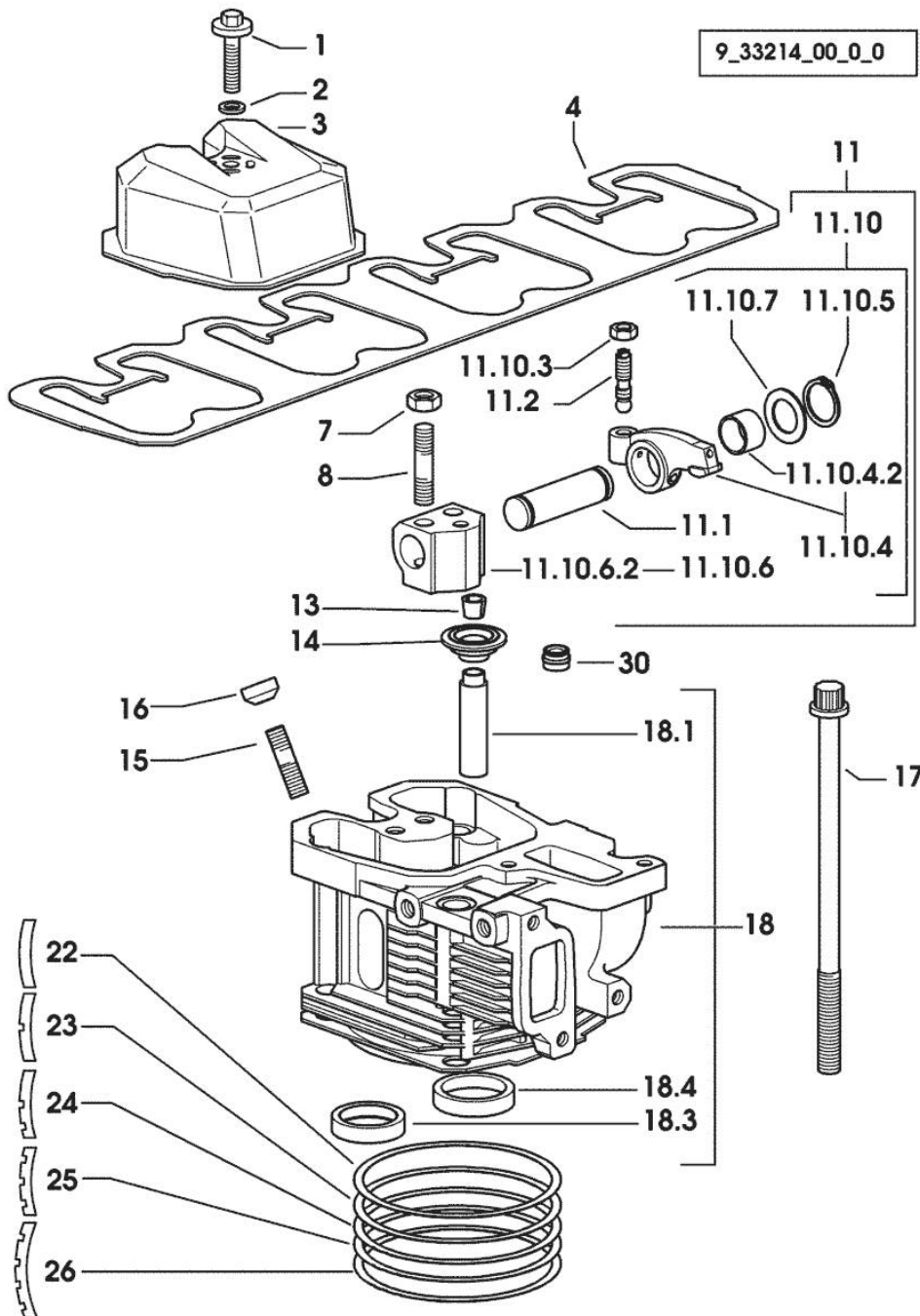

Fig.	P/n	QTY	Name
Notes: [ROCK 70 M]			
1	2.0399.130.2/10	4	screw m 8x36x44 1328 <- X ROCK 70
1	2.0399.288.2/10	4	screw m 8x36x46 -> 1329 X ROCK 70
2	2.1539.151.0	4	special oil seal 9.19 x 2.62 -> 1329 X ROCK 70
2	2.1569.170.0/10	4	gasket 8.2 x 14 1328 <- X ROCK 70
3	0.007.1139.0/10	4	small cap
4	0.065.1450.0/30	1	tappet gasket
7	2.1011.421.2	8	nut m 10 p.1.25
8	2.0432.163.7	8	stud bolt m 10 p.1.5 / p.1.25 x 45
11	0.000.0000.1		cannot be supplied
11.1	0.066.1431.0	1	pin
11.2	0.021.1434.0	2	screw
11.10	0.000.0000.1		cannot be supplied
11.10.3	2.1011.405.2	2	nut m 8 p.1
11.10.4	0.066.1432.3	2	rocker arm
11.10.4.2	2.1559.021.0/40	1	bushing 15x19x22
11.10.5	2.1410.055.7	2	circlip 19
11.10.6	0.000.0000.1		cannot be supplied
11.10.6.2	0.066.1430.0/10	1	support
11.10.7	2.1599.432.0	2	shoulder ring
13	0.074.1423.0	16	conical valve cotter
14	0.066.1425.0	8	cup
15	2.0432.161.7	4	stud bolt m 10 p.1.5 / p.1.25 x 40
16	0.007.1122.0/10	4	bush L = mm 6.4
17	0.065.1443.0/20	16	screw
18	0.007.1110.3/60	4	engine head
18.1	0.007.1779.0/20	2	valve guide
18.3	0.066.1427.0	1	valve seat
18.4	0.078.1426.0	1	valve seat
22	0.085.1450.0/10		head gasket mm 0.50
23	0.085.1451.0/10	3	head gasket mm 0.7
24	0.085.1452.0/10	1	head gasket mm 1.0
25	0.085.1453.0/10	3	head gasket mm 0.8
26	0.013.4598.0	3	head gasket mm 1.3
30	2.1519.117.0	8	special oil seal

<https://www.ebooklibonline.com>

Hello dear friend!

Thank you very much for reading.

Enter the link into your browser.

The full manual is available for immediate download.

<https://www.ebooklibonline.com>