

Section: ENGINE
CRANKCASE

Fig.	P/n	QTY	Name
------	-----	-----	------

Notes:
[MERCURY 85 EXPORT]

0	0.044.0050.6	1	gasket set
1	0.045.1110.4	1	crankcase
2	0.004.8774.3	1	support
3	2.1559.111.0/20	2	special bushing
4	2.1599.144.7	10	shoulder ring 12.5x23x4
5	0.004.8774.3	1	support
6	2.1559.090.0/10	1	bushing 14.24x19.06x27
7	0.037.1114.0	1	support
8	0.052.1113.0	2	support
9	0.052.1116.0	1	support
10	0.021.1157.0	4	stud bolt
11	2.1019.026.7	10	special nut m 12 p.1.5
12	0.029.1117.0	6	stud bolt
13	0.029.1154.0/10	4	gasket
14	2.1699.114.0	1	pin 8x55
15	2.1651.711.0	1	pin 8 x 14
16	2.0432.025.7	2	stud bolt m 8 p.1.25 - 1.00 x 100
17	0.044.1130.0	1	flange
18	2.1653.708.0	2	pin 8x18
19	2.1651.911.0	2	cylindrical plug
20	2.0432.153.7	2	stud bolt m 10 p.1.5 / p.1.25 x 20
21	2.0112.511.2	11	screw m 14 p.2 x 30
22	2.0432.257.7	2	stud bolt m 12 p.1.75 - 1.25 x 30
23	2.3170.022.1	1	expansion plug 60
24	2.3130.003.1	2	plug 3/8" gas
25	2.3130.002.1	1	plug 1/4" gas
26	0.044.1120.0/40	4	engine cylinder
27	2.1589.052.0	8	shoulder ring 115x123x0.2
28	2.1589.051.0	4	shoulder ring 116x123x0.1
29	2.1569.076.0	4	gasket 116x123x0.5
30	0.041.1123.0/10	4	stud bolt
31	0.039.1122.0	16	stud bolt m 12 p.1.5x310
32	0.044.1156.0	8	special bushing
33	0.071.1151.3/10	4	valve
34	2.3130.001.1	4	plug 1/8" gas
35	2.1651.507.0	2	pin 6 x 16
36	2.3139.001.1	5	plug
37	2.0432.003.7	4	stud bolt m 8 p.1.25 / p.1 x 20
38	0.044.1151.0	1	gasket
39	0.044.1164.2/10	1	small cover
39	0.045.1154.2	1	old part number

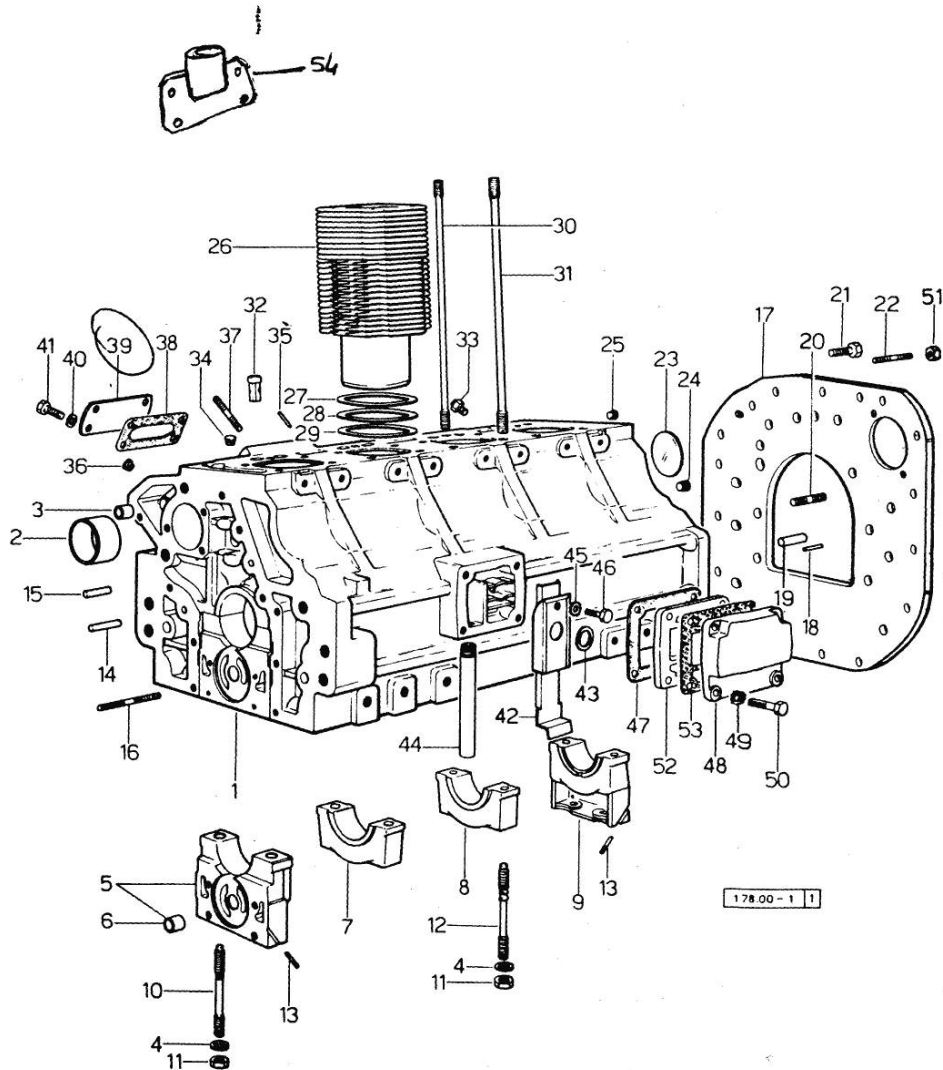

Section: ENGINE
CRANKCASE

Fig.	P/n	QTY	Name
			FOR TYPES WITH ELECTRICAL HEATING
40	2.1310.004.2	4	flat washer 8.4x17
41	2.0112.204.2	2	screw m 8 p.1.25x14
41	2.0112.211.2	2	screw m 8 p.1.25 x 30
			IN TYPES WITH ELECTRICAL HEATING
42	0.044.1162.2	1	small guard
43	0.071.1156.0	1	special oil seal
44	0.044.1152.0/10	1	tube
45	2.1474.009.2	1	spring washer 8
46	2.0312.206.2	1	screw m 8 p 1.25 x 20
47	0.044.1153.0/10	1	gasket
48	0.044.1163.0	1	cover
49	2.1474.009.2	4	spring washer 8
50	2.0112.211.2	4	screw m 8 p.1.25 x 30
51	2.1011.207.2	2	nut m 12 p.1.5
52	0.044.1160.0/10	1	container
53	0.044.1161.0	1	gasket
54	0.045.1153.0	1	flange

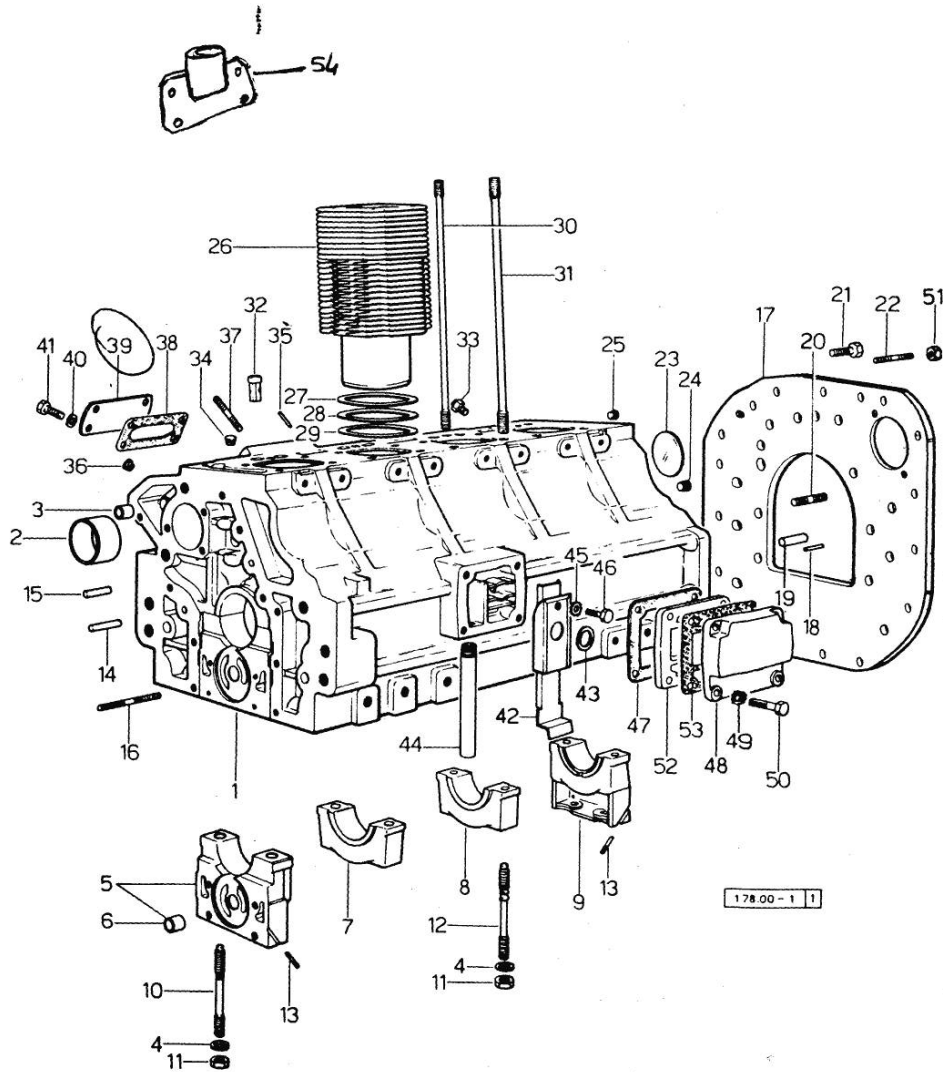

Section: ENGINE

TIMING CASE

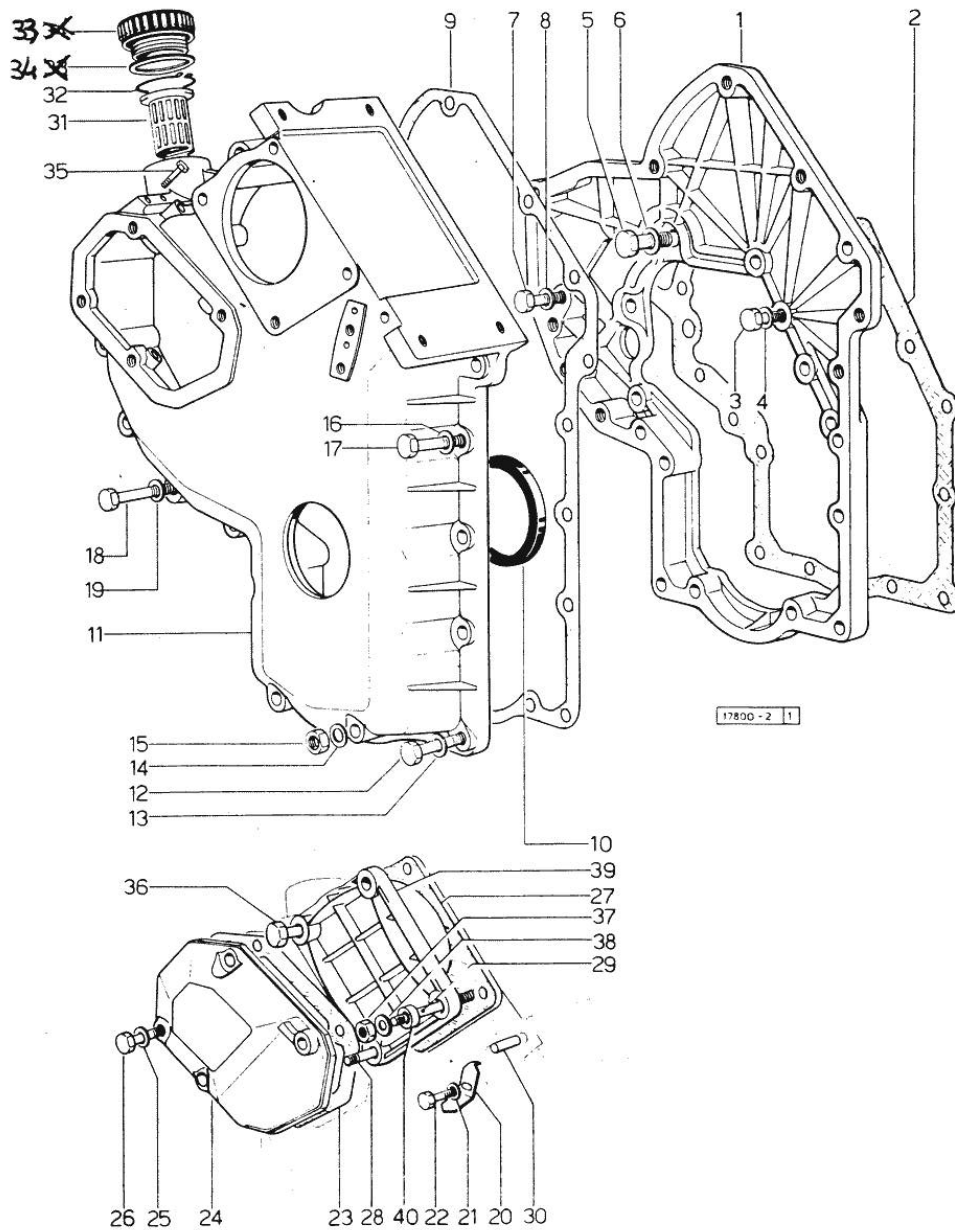

Fig.	P/n	QTY	Name
------	-----	-----	------

Notes:
[MERCURY 85 EXPORT]

1	0.048.1131.0	1	flange
2	0.041.1153.0/10	1	gasket
3	2.0112.209.2	5	screw m 8 p 1.25 x 25
4	2.1474.009.2	5	spring washer 8
5	2.0119.034.2	1	screw m 14 p.2x20
6	2.1560.010.0	1	gasket 14.2 x 20
7	2.0112.207.2	1	screw m 8 p 1.25 x 20
8	2.1474.009.2	1	spring washer 8
9	0.041.1152.0/10	1	gasket
10	2.1519.010.0	1	special oil seal 58x80x10
11	0.048.1132.0/40	1	guard
12	2.0112.217.2	5	screw m 8 p.1.25 x 45
13	2.1474.009.2	5	spring washer 8
14	2.1560.003.0	2	copper gasket 8.2 x 12
15	2.1011.405.2	2	nut m 8 p.1
16	2.1474.009.2	2	spring washer 8
17	2.0112.211.2	2	screw m 8 p.1.25 x 30
18	2.0112.222.2	4	screw m 8 p.1.25x65
19	2.1474.009.2	4	spring washer 8
20	0.041.1158.0	1	index
21	2.1310.004.2	1	flat washer 8.4x17
22	2.0112.204.2	1	screw m 8 p.1.25x14
23	0.048.1151.0/10	1	gasket
24	0.048.1150.0/20	1	cover
25	2.1560.006.0	4	gasket 10.2 x 16
26	2.0112.313.2	1	screw m 10 p.1.5 x 35
26	2.0112.315.2	3	screw m 10 p.1.5 x 40
27	0.041.1154.0	1	gasket
28	2.0432.015.7	1	stud bolt m 8 p.1.25-1x50
29	2.0432.028.7	2	stud bolt m 8 p.1.25-1x130
30	2.1653.717.0	1	pin 8 x 40
31	0.041.1159.0/10	1	filter
32	2.1411.012.1	1	circlip 30
33	0.041.1135.4	1	plug 1" gas
34	2.1569.072.0	1	gasket 32 x 39.5 x 2
35	2.0112.004.2	2	screw m 6 p.1 x 14
36	2.0112.235.2	1	screw m 8 p.1.25 x 130
37	2.1011.405.2	4	nut m 8 p.1
38	2.1310.004.2	4	flat washer 8.4x17
39	0.037.1151.0/10	1	cover
40	2.1579.191.2	4	spacer 8.5 x 18 x 20

<https://www.ebooklibonline.com>

Hello dear friend!

Thank you very much for reading.

Enter the link into your browser.

The full manual is available for immediate download.

<https://www.ebooklibonline.com>

Section: ENGINE

CRANKSHAFT

Fig.	P/n	QTY	Name
------	-----	-----	------

Notes:

[MERCURY 85 EXPORT]

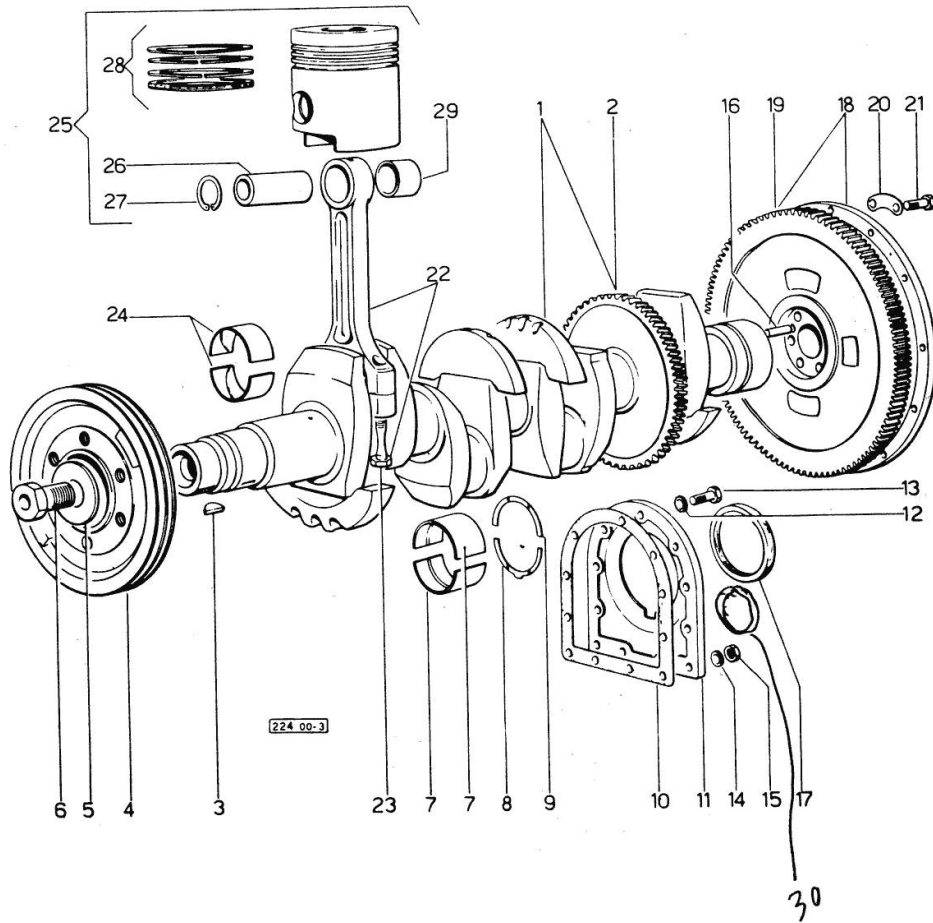

1	0.044.1267.4/30	1	crankshaft
1	2.1630.611.0	1	roll pin 6 x 24
2	0.044.1265.0/20	1	gear
3	2.1799.002.0	1	stick 10x13
4	0.062.1250.0	1	pulley
5	0.001.6020.0	1	shoulder
6	2.0129.032.2	1	screw m 24 p.2x45
7	0.073.0059.0	10	main half bushing - mm 1.00
7	0.073.1215.0	10	main half bushing STANDARD
7	0.073.1215.7	10	main half bushing - mm 0.25
7	0.073.1215.8	10	main half bushing - mm 0.50
7	0.073.1215.9	10	main half bushing - mm 0.75
8	0.001.4547.0	2	shoulder ring + mm 0.05
8	0.001.4548.0	2	shoulder ring + mm 0.10
8	0.001.4549.0	2	shoulder ring + mm 0.15
8	0.042.1219.0	2	shoulder ring STANDARD
9	0.001.4544.0	2	shoulder ring + mm 0.05
9	0.001.4545.0	2	shoulder ring + mm 0.10
9	0.001.4546.0	2	shoulder ring + mm 0.15
9	0.042.1218.0	2	shoulder ring STANDARD
10	0.029.1250.0/10	1	gasket
11	0.029.1240.0	1	flange
12	2.1474.010.2	7	washer 10
13	2.0112.309.2	7	screw m 10 p.1.5 x 25
14	2.1560.006.0	2	gasket 10.2 x 16
15	2.1011.421.2	2	nut m 10 p.1.25
16	2.1651.915.0	2	pin 12x35
17	2.1519.009.0/10	1	special oil seal
18	0.039.1241.3/10	1	flywheel
19	0.036.1242.0	1	crown wheel Z = 126, mm 15
20	2.1379.006.0	3	lock-tab 15x15x36,5
21	2.0122.515.7	6	screw
22	0.039.1220.3/30	4	engine connecting rod
23	0.039.1250.0	8	screw m 14 p.1.5x63
24	0.062.0059.0	8	con.rod half bushing - mm 1.00
24	0.062.1225.0	8	con.rod half bushing STANDARD
24	0.062.1225.7	8	con.rod half bushing - mm 0.25
24	0.062.1225.8	8	con.rod half bushing - mm 0.50
24	0.062.1225.9	8	con.rod half bushing - mm 0.75
25	0.073.0060.6	4	complete piston STANDARD
25	0.073.0061.6	4	complete piston + mm 0.50

Section: ENGINE
CRANKSHAFT

Fig.	P/n	QTY	Name
25	0.073.0062.6	4	complete piston + mm 1.0
26	0.038.1236.0/10	4	piston pin Ø 18 / Ø 35 / L = mm 90
27	2.1411.014.1	8	circlip 35
28	0.042.0052.6	4	piston ring set STANDARD
28	0.042.0053.6	4	piston ring set + mm 0.50
28	0.042.0054.6	4	piston ring set + mm 1.0
29	2.1559.114.0/10	4	special bushing

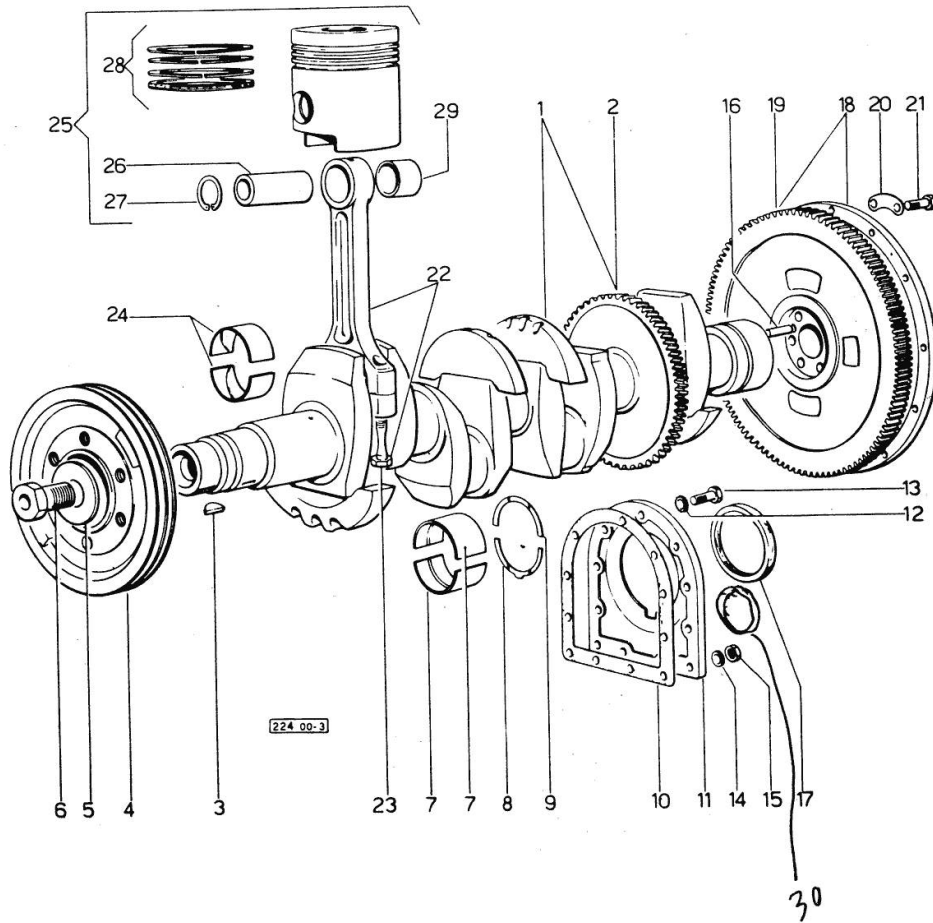

Section: ENGINE

CRANKSHAFT - HARMONIC BALANCER

Fig.	P/n	QTY	Name
------	-----	-----	------

Notes:
[MERCURY 85 EXPORT]

1	0.044.1263.3/20	1	mass sx/lh/li
1	2.1559.115.0	2	special bushing 26x30x30
2	0.044.1261.3/10	1	mass dx/rh/re
2	2.1559.115.0	2	special bushing 26x30x30
3	2.1589.050.0/10	4	shoulder ring 26.1x38x1
4	0.044.1266.0/20	2	shaft
5	0.044.1260.0/30	1	support
6	2.1589.049.0	2	shoulder ring 12.5x26x0.3
7	2.1579.629.0	2	spacer 12.5x26x0.1
8	2.1579.626.0	2	spacer 13.2x16x11
9	2.1579.628.0	1	spacer 16.5x26x0.1
10	2.1589.048.0	1	shoulder ring 16.5x26x0.3
11	2.1379.038.0	2	shim mm 0.1
12	2.1379.039.0	1	shim mm 0.3
13	2.0112.426.2	2	screw m 12 p.1.75x85
14	2.1631.717.0	2	roll pin 8 x 40
15	2.1310.004.2	1	flat washer 8.4x17
15	2.1474.009.2	2	spring washer 8
16	2.0112.204.2	3	screw m 8 p.1.25x14
17	2.3339.515.1/10	1	pipe union m 12 p.1.25x39
18	2.3319.041.1	1	pipe union m 12 p.1.25-p.1.75
19	2.1560.008.0	7	gasket 12.2 x 18
20	0.044.1562.2	1	tube
21	2.1019.048.1	1	special nut m 12 p.1.5
22	2.3332.003.1	1	pipe union m 12 p.1.25
23	0.319.1550.3	1	tube

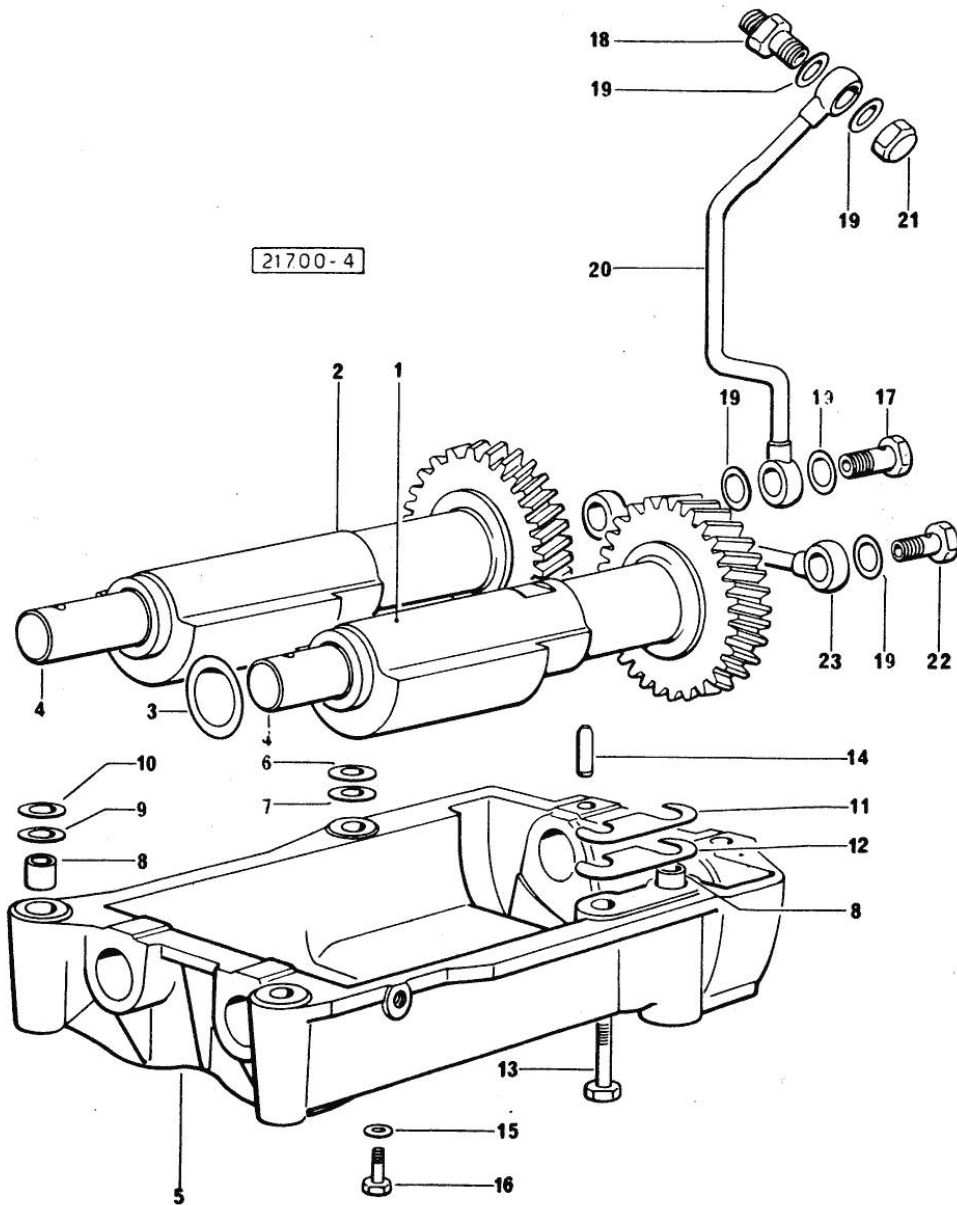

Section: ENGINE
CAMSHAFT

Fig.	P/n	QTY	Name
------	-----	-----	------

Notes:
 [MERCURY 85 EXPORT]

1	0.044.1310.0/40	1	camshaft
2	2.3130.001.1	1	plug 1/8" gas
3	0.027.1314.0/20	1	flange
4	2.1470.004.2	2	lock washer 8
5	2.0112.207.2	2	screw m 8 p 1.25 x 20
6	0.062.1321.0	1	gear z=66
7	2.0139.005.1	4	screw m 10 p.1 x 25
8	0.040.1320.0	1	gear z = 33
9	2.1720.010.0	1	key 5x9
10	0.040.1323.0/10	1	gear Z = 38
11	0.052.1330.0/20	8	tappets
12	0.041.1331.3	8	rod
13	0.041.1332.0	8	sleeve
14	2.1539.020.0	8	special oil seal 13.95x2.62
15	2.1539.022.0	8	special oil seal 12.37x2.62
16	2.4019.162.1/20	8	spring 17.2x46x1.8
17	0.041.1355.3	1	transmission
18	2.1560.014.0	1	washer 18.2 x 24

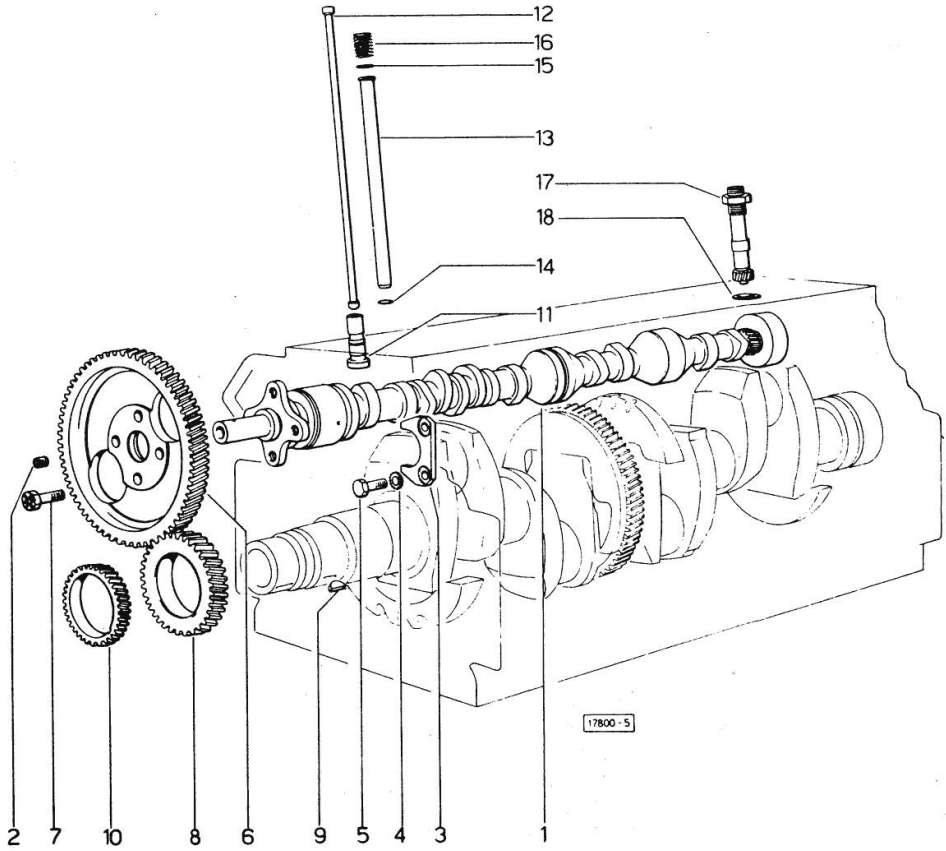

Section: ENGINE
CYLINDER HEAD

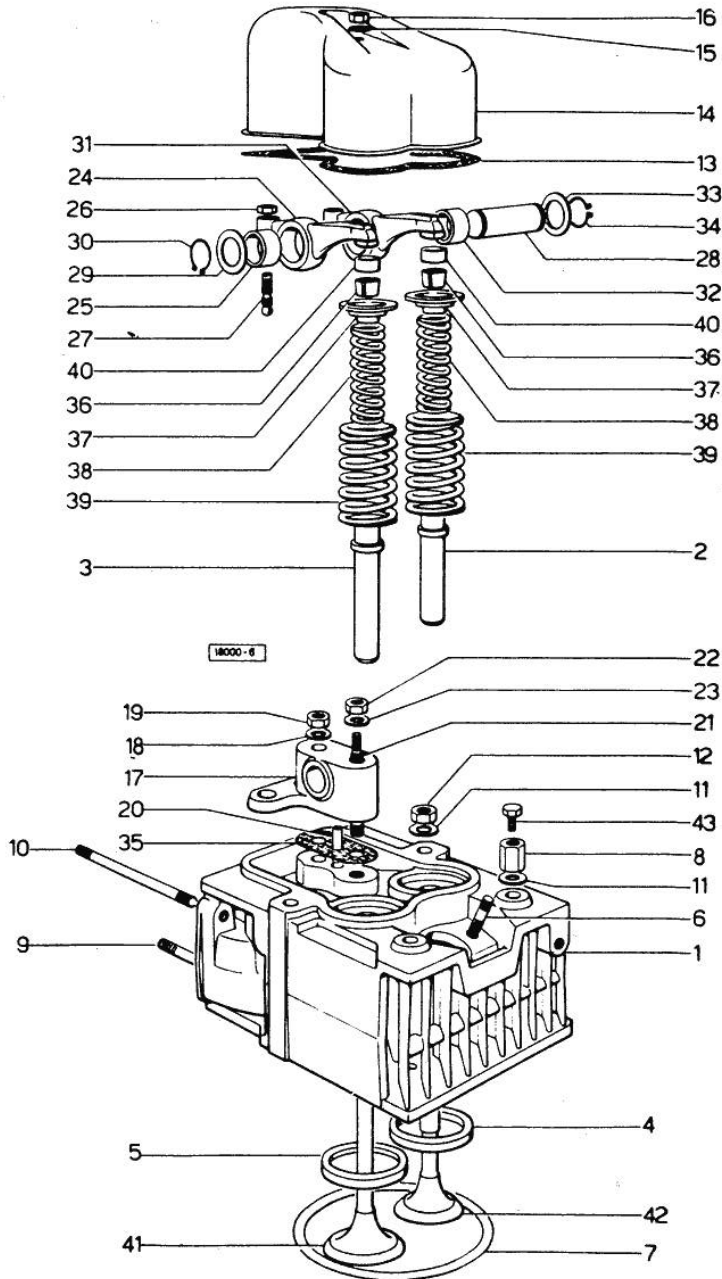

Fig.	P/n	QTY	Name
------	-----	-----	------

Notes:
[MERCURY 85 EXPORT]

0	0.073.0057.6	1	gasket set
1	0.044.1450.3/50	4	engine head
2	0.045.1417.0	4	valve guide
3	0.037.1416.0	4	valve guide
4	0.037.1452.0/10	4	valve seat
5	0.037.1451.0/10	4	valve seat
6	2.0439.087.1/20	8	stud bolt m 8 p.1.25 / p.1 x 40
7	2.1569.078.0/10	4	gasket 106x118x0.5
8	2.1019.037.0	4	special nut m 12 p.1.5
9	2.0432.007.2	7	stud bolt m 8 p.1.25 / p.1 x 30
10	2.0432.027.7	4	stud bolt m 8 p 1.25 - 1.00 x 120
11	2.1599.144.7	18	shoulder ring 12.5x23x4
12	2.1019.025.0	14	special nut m 12 p.1.5
13	0.029.1450.0/20	4	tappet gasket
14	0.039.1440.0	4	cap
15	2.1560.004.0	4	copper gasket 8.2 x 14
16	2.1099.056.2	4	special nut m 8 p.1 x 8
17	0.041.1430.0	4	support
18	2.1599.160.0	4	washer 10.5x19x4
19	2.1099.035.0	4	special nut m 10 p.1.25
20	0.029.1452.0	4	tube
21	0.039.1451.0	4	stud bolt
22	2.1011.421.2	4	nut m 10 p.1.25
23	2.1310.006.2	4	flat washer 10.5x21
24	002.5937.3/30	4	rocker arm
25	2.1559.021.0/40	4	bushing 15x19x22
26	2.1011.405.2	8	nut m 8 p.1
27	0.021.1434.0	8	screw
28	0.041.1431.0	4	pin
29	2.1599.019.0	4	shoulder ring 19.5x31x2
30	2.1410.055.7	4	circlip 19
31	0.002.5936.3/40	4	rocker arm
32	2.1559.021.0/40	4	bushing 15x19x22
33	2.1599.019.0	4	shoulder ring 19.5x31x2
34	2.1410.055.7	4	circlip 19
35	0.034.1450.0	4	tappet gasket
36	0.074.1423.0	8	conical valve cotter
37	0.002.9215.0/20	8	cup
38	2.4019.194.0	8	spring 22.70x50.7x2.1
39	2.4019.193.0	8	spring 36.15x55.2x3.2
40	0.021.1453.0/20	8	small cover



Suggest:

For more complete manuals. Please go to the home page.

<https://www.ebooklibonline.com>

If the above button click is invalid. Please download this document first, and then click the above link to download the complete manual.

Thank you so much for reading

Section: ENGINE
CYLINDER HEAD

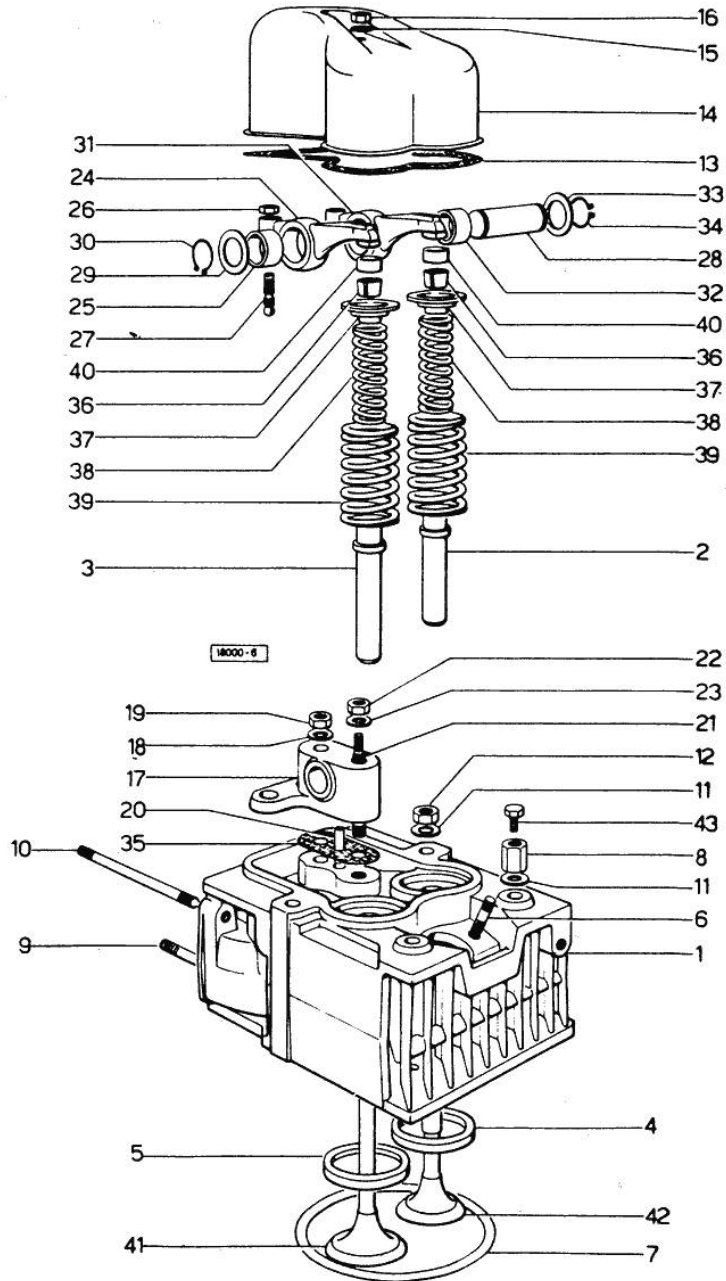

Fig.	P/n	QTY	Name
41	0.052.1420.0	4	inlet valve Ø mm 9
42	0.039.1421.0	4	exhaust valve Ø mm 9
43	2.0119.053.1	2	screw

Section: ENGINE
LUBRICATION

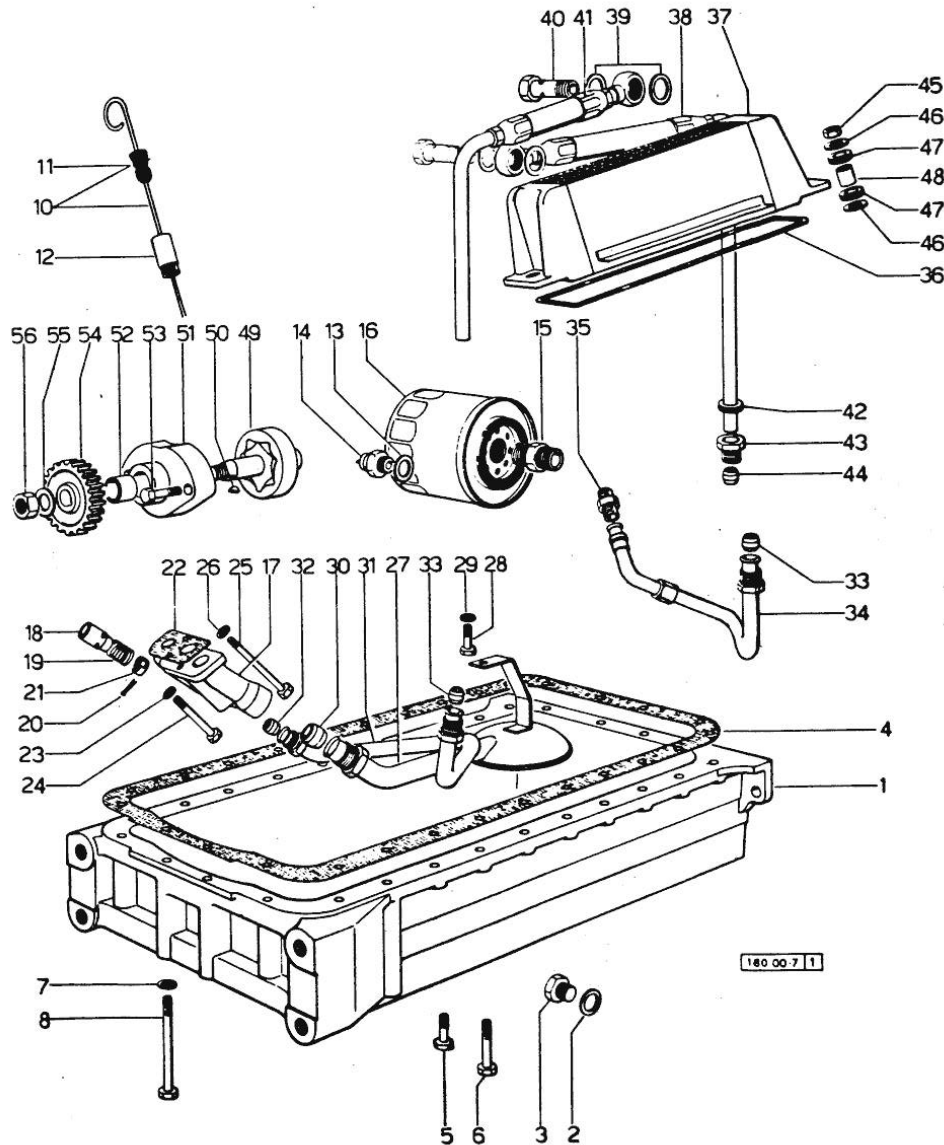

Fig.	P/n	QTY	Name
------	-----	-----	------

Notes:
[MERCURY 85 EXPORT]

1	0.045.1510.0	1	oil sump
2	2.1560.054.0	1	gasket 21 x 26
3	2.3199.001.2	1	plug 1/2" gas
4	0.036.1512.0	1	gasket
5	2.0112.211.2	2	screw m 8 p.1.25 x 30
6	2.0112.224.2	18	screw m 8 p.1.25x75
6	2.0112.229.2	2	screw m 8 p.1.25 x 100
7	2.1560.004.0	4	copper gasket 8.2 x 14
8	2.0112.217.2	2	screw m 8 p.1.25 x 45
8	2.0112.231.2	2	screw m 8 p.1.25 x 110
8	2.0112.235.2	2	screw m 8 p.1.25 x 130
10	0.045.1513.3	1	dipstick
11	0.034.1551.0	1	gasket
12	0.044.1555.0	1	spacer
13	2.1560.008.0	1	gasket 12.2 x 18
14	2.7099.460.0	1	pressure switch
15	2.3339.094.1/10	1	pipe fitting m 20 p.1.5-3/4 gas
16	0.044.1567.0	1	oil filter element
17	0.052.1530.0	1	tip
18	0.040.1550.0	1	small piston
18	0.052.1571.0	1	small piston => 42086
19	2.4019.241.1	1	spring
19	2.4019.270.1	1	spring 9.7x54x2 => 42086
20	2.1630.213.0	1	roll pin 3x32
21	0.040.1551.0	1	stop
21	0.054.1558.0/20	1	stop => 42086
22	0.037.1557.0/20	1	gasket
23	2.1474.009.2	1	spring washer 8
24	2.0112.225.2	1	screw m 8 p.1.25 x 80
25	2.0112.231.2	1	screw m 8 p.1.25 x 110
26	2.1474.009.2	1	spring washer 8
27	0.044.1556.3/10	1	tube
28	2.0112.204.2	1	screw m 8 p.1.25x14
29	2.1310.004.2	1	flat washer 8.4x17

<https://www.ebooklibonline.com>

Hello dear friend!

Thank you very much for reading.

Enter the link into your browser.

The full manual is available for immediate download.

<https://www.ebooklibonline.com>