

Section: ENGINE
CRANKCASE

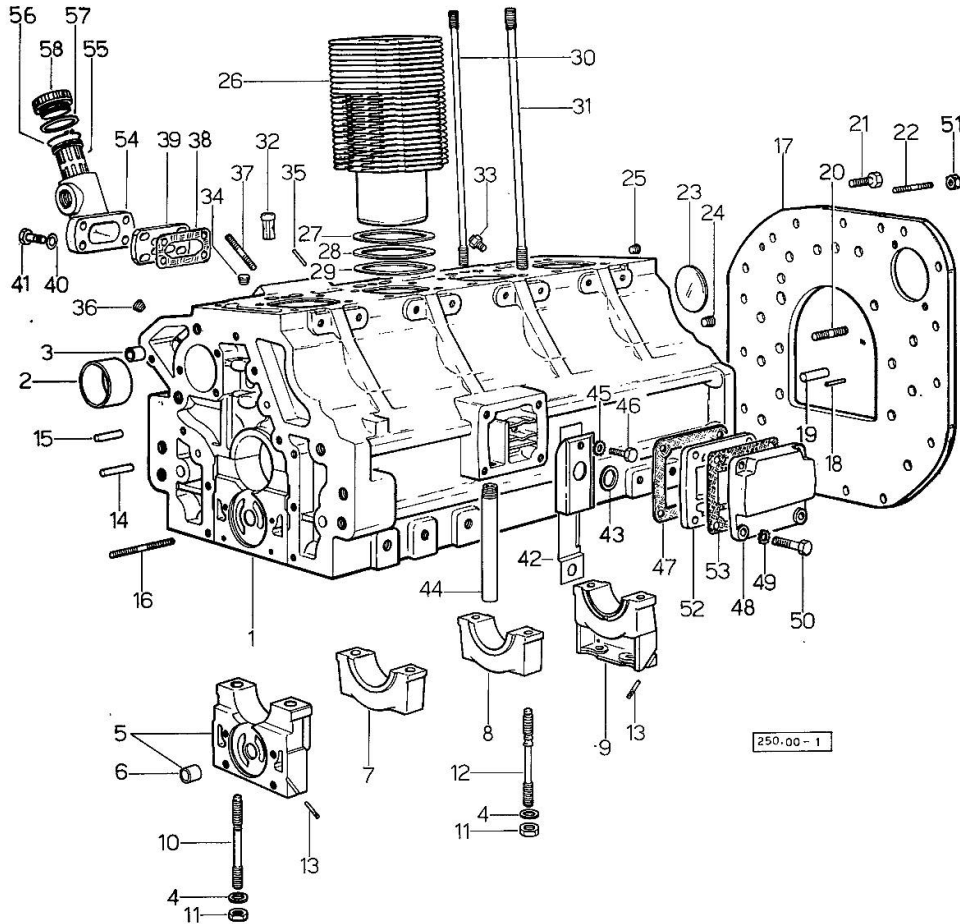

Fig.	P/n	QTY	Name
------	-----	-----	------

Notes:
[LEOPARD 90 Turbo]

0	0.062.0050.6	1	gasket set - FOR ENGINE MOUNTING
1	0.045.1110.4	1	crankcase
2	0.037.1155.0	1	bushing
3	2.1559.111.0	2	bushing 12x14x10
4	2.1599.144.7	10	shoulder ring 12.5x23x4
5	0.004.8775.0	1	support
6	2.1559.090.0/10	1	bushing 14.24x19.06x27
7	0.037.1114.0	1	support
8	0.029.1113.0	2	support
9	0.029.1116.0	1	support
10	0.021.1157.0	4	stud bolt
11	2.1019.026.7	10	special nut m 12 p.1.5
12	0.029.1117.0	6	stud bolt
13	0.029.1154.0	4	gasket
14	2.1699.114.0	1	pin 8x55
15	2.1653.711.0	1	pin
16	2.0432.025.1	2	stud bolt m 8 p 1.25-1x100
17	0.044.1159.0	1	flange
18	2.1653.708.0	2	pin 8x18
19	2.1652.911.0	2	cylindrical plug 12x25
20	2.0432.153.1	2	stud bolt m 10 p.1.5 / p.1.25 x 20
21	2.0112.513.1	11	screw m 14 p.2 x 35
22	2.0432.255.1	2	stud bolt m 12 p.1.75 - 12 p.1.25x25
23	2.3170.022.1	1	expansion plug 60
24	2.3130.003.1	2	plug 3/8" gas
25	2.3130.002.1	1	plug 1/4" gas
26	0.044.1120.0/10	4	engine cylinder
27	2.1589.052.0	8	shoulder ring 115x123x0.2
28	2.1589.051.0	4	shoulder ring 116x123x0.1
29	2.1569.076.0	4	gasket 116x123x0.5
30	0.041.1123.0	4	stud bolt m 10
31	0.039.1122.0	16	stud bolt m 12 p.1.5x310
32	0.044.1156.0	8	special bushing
33	0.052.1159.3	4	old part number
34	2.3130.001.1	4	plug 1/8" gas
35	2.1653.507.0	2	pin
36	2.3139.001.1	5	plug
37	2.0432.003.1	4	stud bolt m 8 p.1.25 / p.1 x 20
38	0.044.1151.0	2	gasket
39	0.045.1154.2	1	old part number

Section: ENGINE
CRANKCASE

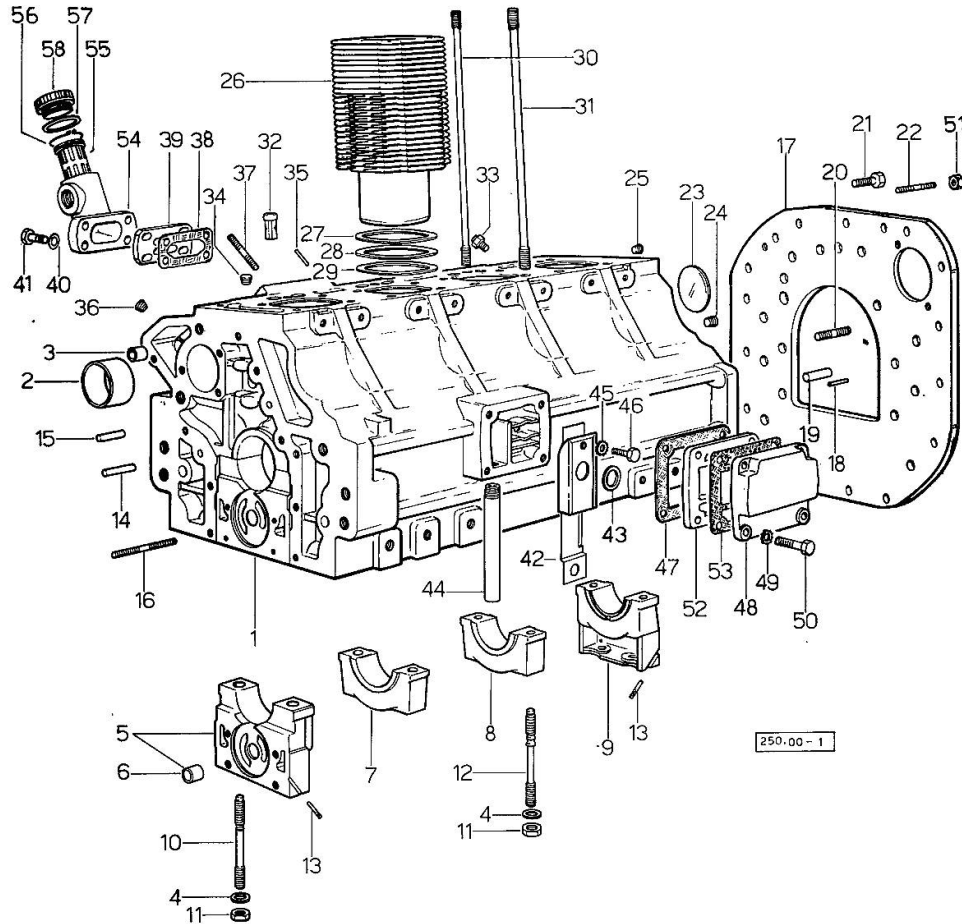

Fig.	P/n	QTY	Name
40	2.1310.004.2	4	flat washer 8.4x17
41	2.0112.211.2	4	screw m 8 p.1.25 x 30
42	0.044.1162.2	1	small guard
43	0.045.1150.0	1	oil seal
44	0.044.1152.0	1	tube
45	2.1474.009.1	1	spring washer 8
46	2.0312.206.2	1	screw m 8 p 1.25 x 20
47	0.044.1153.0/10	1	gasket
48	0.044.1163.0	1	cover
49	2.1474.009.1	4	spring washer 8
50	2.0112.211.2	4	screw m 8 p.1.25 x 30
51	2.1011.207.2	2	nut m 12 p.1.5
52	0.044.1160.0	1	container
53	0.044.1161.0	1	gasket
54	0.062.1150.0	1	old part number
55	0.041.1159.0/10	1	filter
56	2.1411.012.1	1	circlip 30
57	2.1569.072.0	1	gasket 32 x 39.5 x 2
58	0.041.1135.0	1	plug

Section: ENGINE

TIMING CASE

Fig.	P/n	QTY	Name
------	-----	-----	------

Notes:
[LEOPARD 90 Turbo]

1	0.048.1131.0	1	flange
2	0.041.1153.0	1	gasket
3	2.0112.209.2	5	screw m 8 p 1.25 x 25
4	2.1474.009.1	5	spring washer 8
5	2.0119.034.1	1	screw m 14 p.2x20
6	2.1560.010.0	1	gasket 14.2 x 20
7	2.0112.207.2	1	screw m 8 p 1.25 x 20
8	2.1474.009.1	1	spring washer 8
9	0.041.1152.0	1	gasket
10	2.1519.010.0	1	special oil seal 58x80x10
11	0.048.1132.0/30	1	guard
12	2.0112.217.2	5	screw m 8 p.1.25 x 45
13	2.1474.009.1	5	spring washer 8
14	2.1560.003.0	2	copper gasket 8.2 x 12
15	2.1011.405.2	2	nut m 8 p.1
16	2.1474.009.1	2	spring washer 8
17	2.0112.211.2	2	screw m 8 p.1.25 x 30
18	2.0112.222.2	4	screw m 8 p.1.25x65
19	2.1474.009.1	4	spring washer 8
20	0.041.1158.0	1	index
21	2.1310.004.2	1	flat washer 8.4x17
22	2.0112.204.2	1	screw m 8 p.1.25x14
23	0.048.1152.0	1	gasket
24	0.048.1150.0/20	1	cover
25	2.1560.005.0	4	copper gasket 10.2 x 14
26	2.0112.315.2	4	screw m 10 p.1.5 x 40
27	0.041.1154.0	1	gasket
28	2.0432.015.1	1	stud bolt m 8 p 1.25 - m 8 p. 1x50
29	2.0432.028.1	2	stud bolt m 8 p.1.25-1x130
30	2.1653.717.0	1	pin 8 x 40
31	2.3199.002.2	1	plug 1 gas
32	2.1569.072.0	1	gasket 32 x 39.5 x 2
33	0.037.1151.0	1	cover
34	2.1579.191.0	4	spacer 8.5 x 18 x 20
35	2.1310.004.2	4	flat washer 8.4x17
36	2.0112.235.2	1	screw m 8 p.1.25 x 130
37	2.1011.505.2	4	nut m 8 p.1

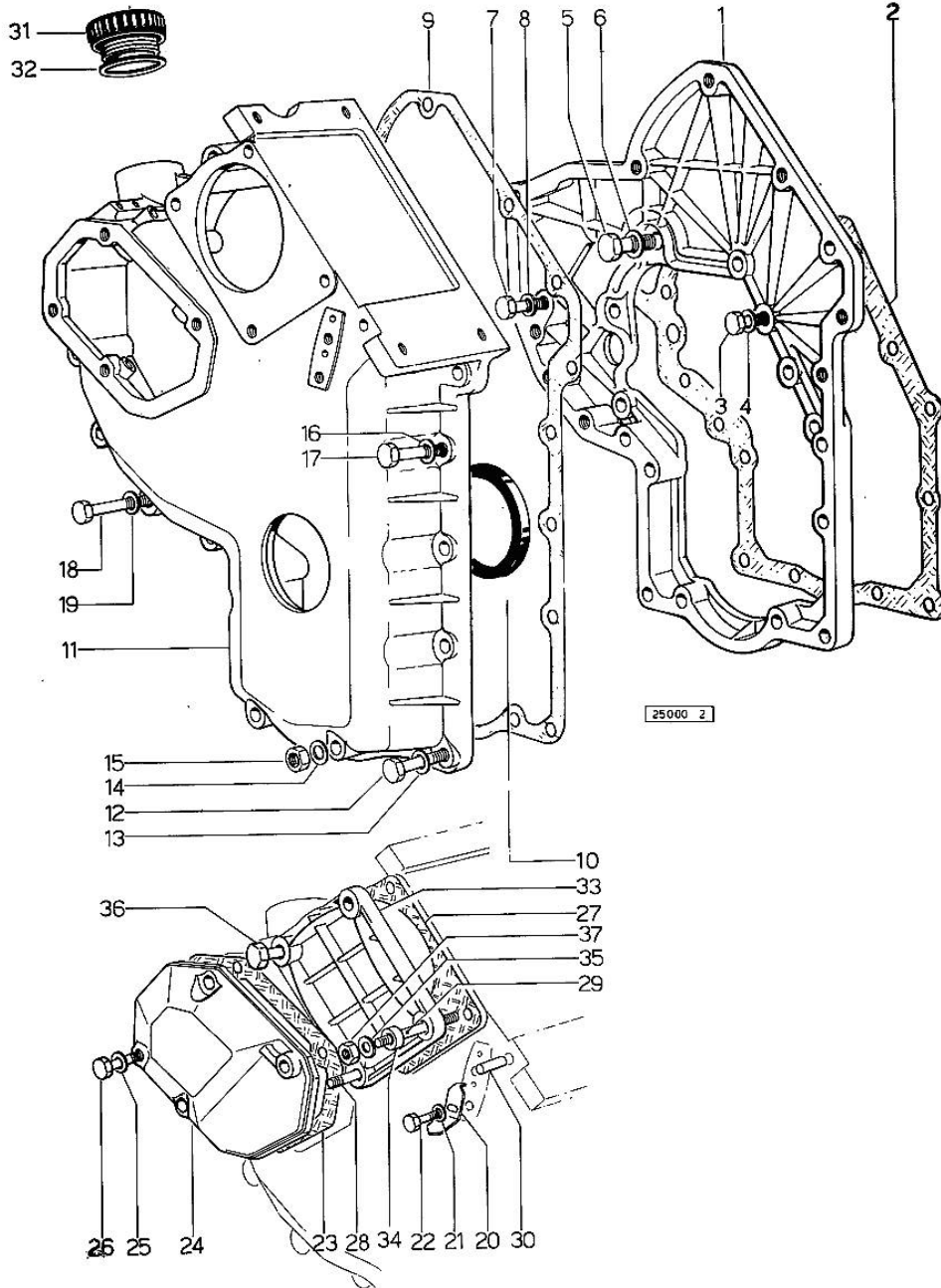

<https://www.ebooklibonline.com>

Hello dear friend!

Thank you very much for reading.

Enter the link into your browser.

The full manual is available for immediate download.

<https://www.ebooklibonline.com>

Section: ENGINE

CRANKSHAFT

Fig.	P/n	QTY	Name
------	-----	-----	------

Notes:

[LEOPARD 90 Turbo]

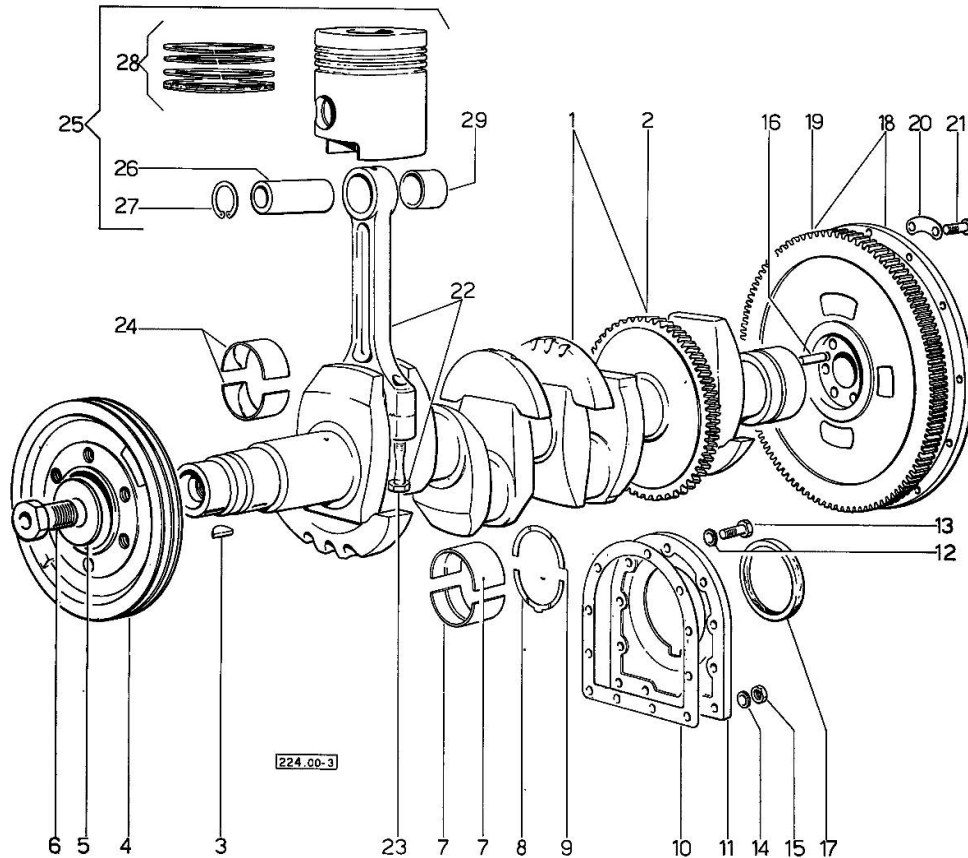

1	0.044.1267.3/20	1	crankshaft
1	0.044.1267.4/20	1	crankshaft
1	2.1630.611.0	1	roll pin 6 x 24
2	0.044.1265.0/10	1	gear
3	2.1799.002.0	1	stick 10x13
4	0.054.1250.0	1	pulley
5	0.001.6020.0	1	shoulder
6	2.0129.032.2	1	screw m 24 p.2x45
7	0.029.0066.0	10	main half bushing - mm 1.00
7	0.029.1215.0/10	10	main half bushing
7	0.029.1215.7	10	main half bushing - mm 0.25
7	0.029.1215.8	10	main half bushing - mm 0.50
7	0.029.1215.9	10	main half bushing - mm 0.75
8	0.001.4547.0	2	shoulder ring + mm 0.05
8	0.001.4548.0	2	shoulder ring + mm 0.10
8	0.001.4549.0	2	shoulder ring + mm 0.15
8	0.042.1219.0	2	shoulder ring STANDARD
9	0.001.4544.0	2	shoulder ring + mm 0.05
9	0.001.4545.0	2	shoulder ring + mm 0.10
9	0.001.4546.0	2	shoulder ring + mm 0.15
9	0.042.1218.0	2	shoulder ring STANDARD
10	0.029.1250.0	1	gasket
11	0.029.1240.0	1	flange
12	2.1474.010.1	7	spring washer 10
13	2.0112.309.2	7	screw m 10 p.1.5 x 25
14	2.1560.006.0	2	gasket 10.2 x 16
15	2.1011.421.2	2	nut m 10 p.1.25
16	2.1652.915.0	2	cylindrical plug 12x35
17	2.1519.009.0	1	special oil seal
18	0.042.1241.3	1	flywheel
18	0.052.1258.3/10	1	FOR BORG & BECK CLUTCH old part number
19	0.036.1242.0	1	FOR VALEO CLUTCH crown wheel Z = 126, mm 15
20	2.1379.006.0	3	lock-tab 15x15x36,5
21	2.0122.515.7	6	screw
22	0.052.1220.3	4	engine connecting rod
23	0.039.1250.0	8	screw m 14 p.1.5x63
24	0.039.0068.0	8	con.rod half bushing - mm 1.016
24	0.039.1225.0	8	con.rod half bushing
24	0.039.1225.7	8	con.rod half bushing -mm 0.254

CRANKSHAFT

Fig.	P/n	QTY	Name
24	0.039.1225.8	8	con.rod half bushing -mm 0.508
24	0.039.1225.9	8	con.rod half bushing -mm 0.762
25	0.062.0060.6	4	old part number
25	0.062.0061.6	4	old part number
25	0.062.0062.6	4	old part number
26	0.038.1236.0	4	piston pin
27	2.1411.014.1	8	circlip 35
28	0.062.0052.6	4	old part number
28	0.062.0053.6	4	old part number
28	0.062.0054.6	4	old part number
29	0.002.4168.0	4	bearing

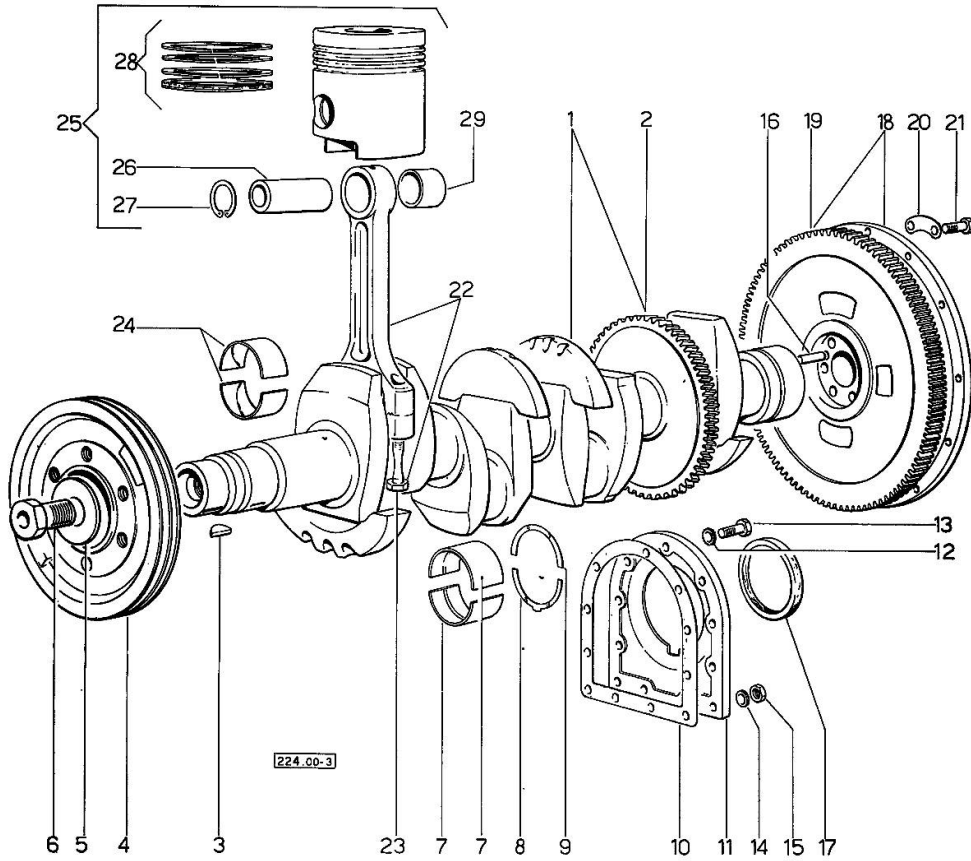

Section: ENGINE

CRANKSHAFT - HARMONIC BALANCER

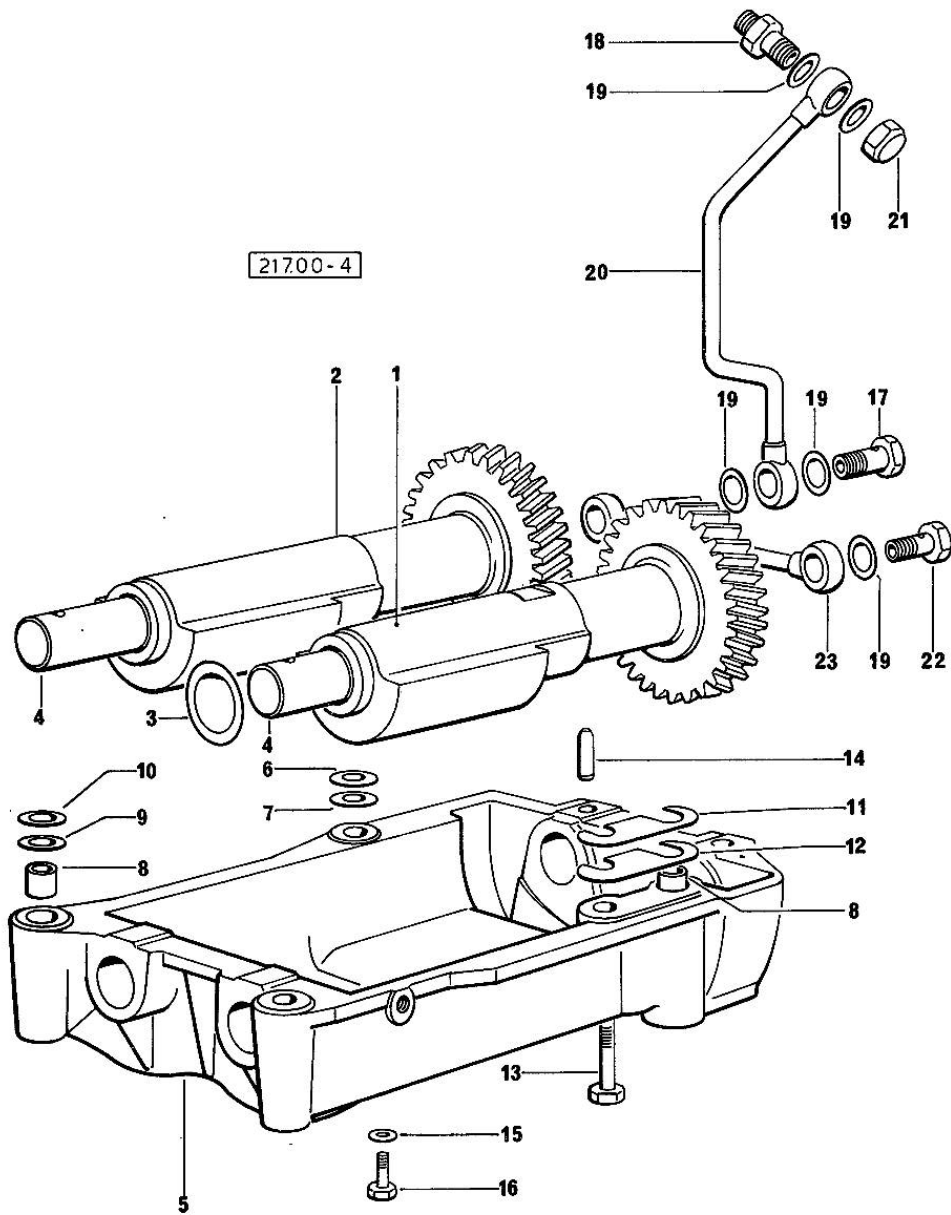

Fig.	P/n	QTY	Name
------	-----	-----	------

Notes:
[LEOPARD 90 Turbo]

1	0.044.1263.3/20	1	mass sx/lh/li
1	2.1559.115.0	2	special bushing 26x30x30
2	0.044.1261.3/10	1	mass dx/rh/re
2	2.1559.115.0	2	special bushing 26x30x30
3	2.1589.050.0	4	shim
4	0.044.1266.0/20	2	shaft
5	0.044.1260.0/30	1	support
6	2.1589.049.0	2	shoulder ring 12.5x26x0.3
7	2.1579.629.0	2	spacer 12.5x26x0.1
8	2.1579.626.0	2	spacer 13.2x16x11
9	2.1579.628.0	1	spacer 16.5x26x0.1
10	2.1589.048.0	1	shoulder ring 16.5x26x0.3
11	2.1379.038.0	2	shim mm 0.1
12	2.1379.039.0	1	shim mm 0.3
13	2.0112.426.1	4	screw m 12 p.1.75x85
14	2.1631.717.0	2	roll pin 8 x 40
15	2.1310.004.2	1	flat washer 8.4x17
15	2.1474.009.1	1	spring washer 8
16	2.0112.204.2	2	screw m 8 p.1.25x14
17	2.3339.515.1	1	pipe union m 12 p.1.25
18	2.3319.041.1	1	pipe union m 12 p.1.25-p.1.75
19	2.1560.007.0	7	gasket 12.2x16
20	0.044.1562.2	1	tube
21	2.1019.048.1	1	special nut m 12 p.1.5
22	2.3332.003.1	1	pipe union m 12 p.1.25
23	0.319.1550.3	1	tube

Section: ENGINE

CAMSHAFT

Fig.	P/n	QTY	Name
------	-----	-----	------

Notes:

[LEOPARD 90 Turbo]

1	0.044.1310.0/30	1	camshaft
2	2.3130.001.1	1	plug 1/8" gas
3	0.027.1314.0	1	flange
4	2.1470.004.2	2	lock washer 8
5	2.0112.207.2	2	screw m 8 p 1.25 x 20
6	0.041.1321.0	1	gear z = 66
7	2.0139.005.1	4	screw m 10 p.1 x 25
8	0.040.1320.0	1	gear z = 33
9	2.1720.010.0	1	key 5x9
10	0.040.1323.0/10	1	gear Z = 38
11	0.044.1330.0/10	8	tappets
12	0.041.1331.3	8	rod
13	0.041.1332.0	8	sleeve
14	2.1539.020.0	8	special oil seal 13.95x2.62
15	2.1539.022.0	8	special oil seal 12.37x2.62
16	2.4019.162.1/20	8	spring 17.2x46x1.8
17	0.041.1355.3	1	transmission
18	2.1560.013.0	1	gasket 18.2x22

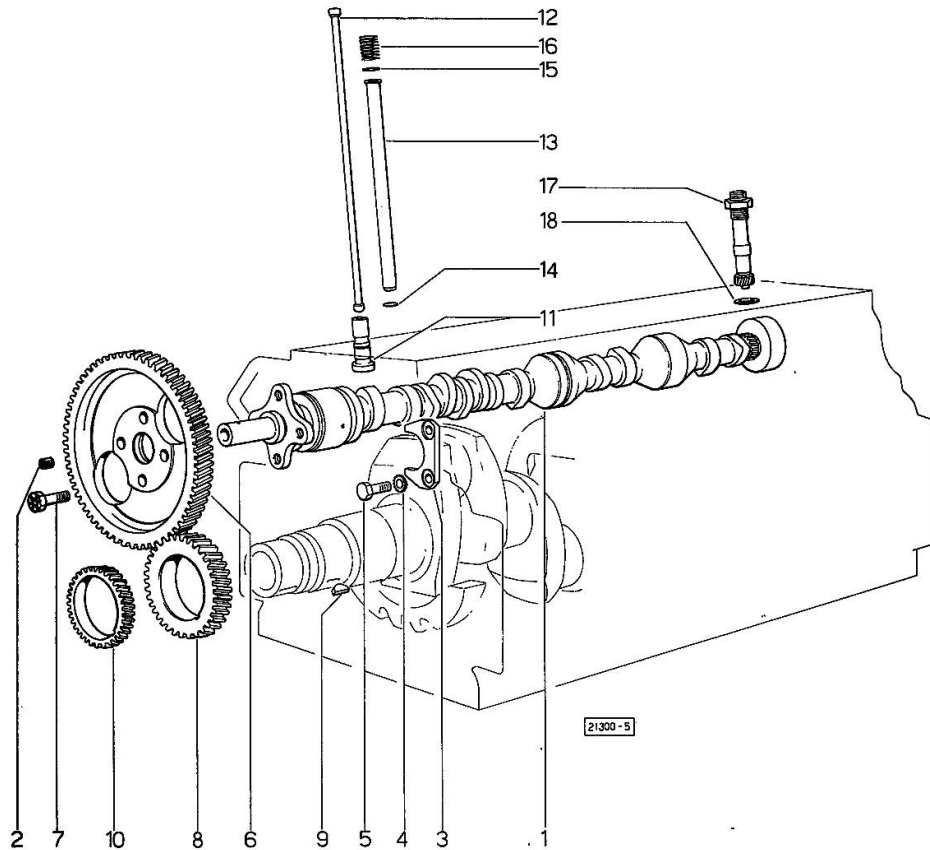

Section: ENGINE
CYLINDER HEAD

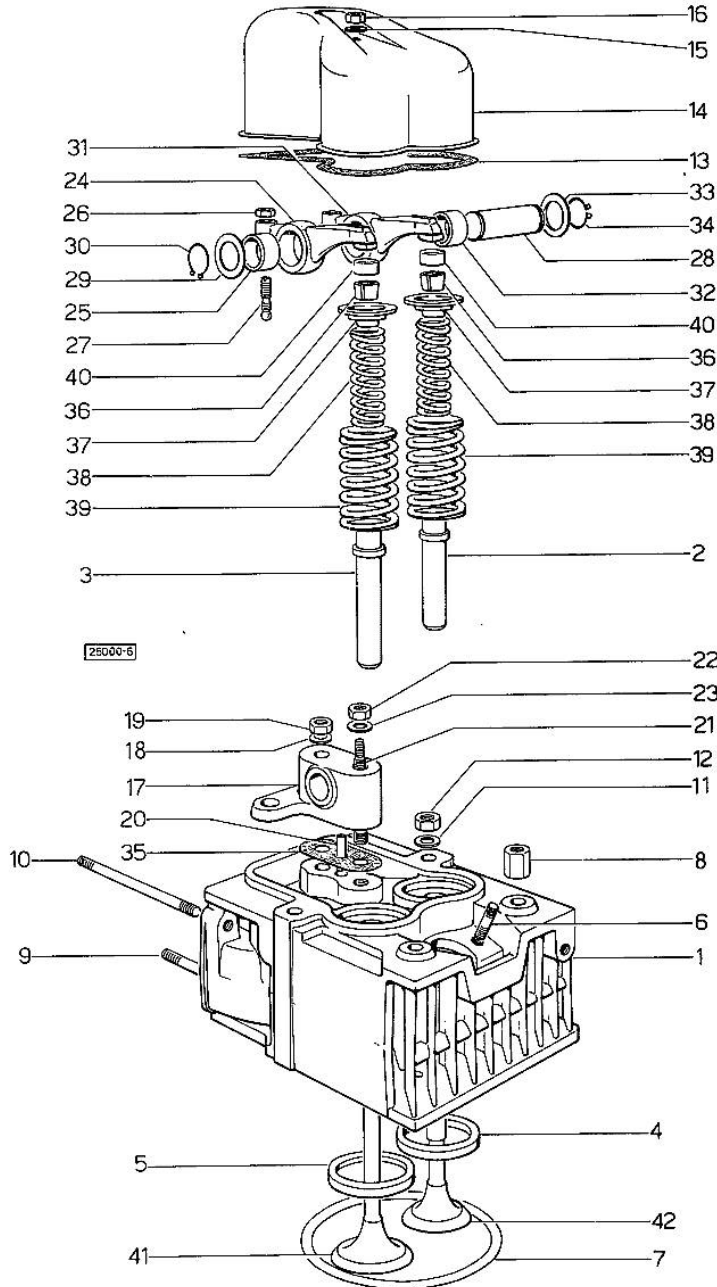

Fig.	P/n	QTY	Name
------	-----	-----	------

Notes:
[LEOPARD 90 Turbo]

0	0.062.0057.6	1	gasket set - FOR 1 CYLINDER VALVE GRINDING AND PISTON RINGS REPLACEMENT
1	0.062.1410.3	4	old part number
2	0.062.1417.0	4	old part number
3	0.062.1416.0	4	valve guide
4	0.062.1450.0	4	old part number
5	0.062.1451.0	4	old part number
6	2.0439.087.1	8	stud bolt
7	2.1569.078.0/10	4	gasket 106x118x0.5
8	2.1019.037.0	2	special nut m 12 p.1.5
9	2.0432.007.1	8	stud bolt m 8 p.1.25 / p.1 x 30
10	2.0432.026.1	4	stud bolt m 8 p.1.25 - 1.00 x 110
11	2.1599.406.0	16	shoulder ring
12	2.1019.025.0	14	special nut m 12 p.1.5
13	0.029.1450.0	4	gasket
14	0.039.1440.0	4	cap
15	2.1560.004.0	4	copper gasket 8.2 x 14
16	2.1099.056.1	4	special nut m8 p.1
17	0.041.1430.0	4	support
18	2.1599.160.0	4	washer 10.5x19x4
19	2.1099.035.0	4	special nut m 10 p.1.25
20	0.029.1452.0	4	tube
21	0.039.1451.0	4	stud bolt
22	2.1011.421.2	4	nut m 10 p.1.25
23	2.1310.006.2	4	flat washer 10.5x21
24	002.5937.3/30	4	rocker arm
25	2.1559.021.0/40	4	bushing 15x19x22
26	2.1011.405.2	8	nut m 8 p.1
27	0.021.1434.0	8	screw
28	0.041.1431.0	4	pin
29	2.1599.019.0	4	shoulder ring 19.5x31x2
30	2.1410.055.1	4	circlip 19
31	0.002.5936.3/40	4	rocker arm
32	2.1559.021.0/40	4	bushing 15x19x22
33	2.1599.019.0	4	shoulder ring 19.5x31x2
34	2.1410.055.1	4	circlip 19
35	0.034.1450.0	4	tappet gasket
36	0.002.9193.0/10	8	conical valve cotter
37	0.002.9215.0/10	8	cup
38	2.4019.194.0	8	spring 22.70x50.7x2.1



Suggest:

For more complete manuals. Please go to the home page.

<https://www.ebooklibonline.com>

If the above button click is invalid. Please download this document first, and then click the above link to download the complete manual.

Thank you so much for reading

CYLINDER HEAD

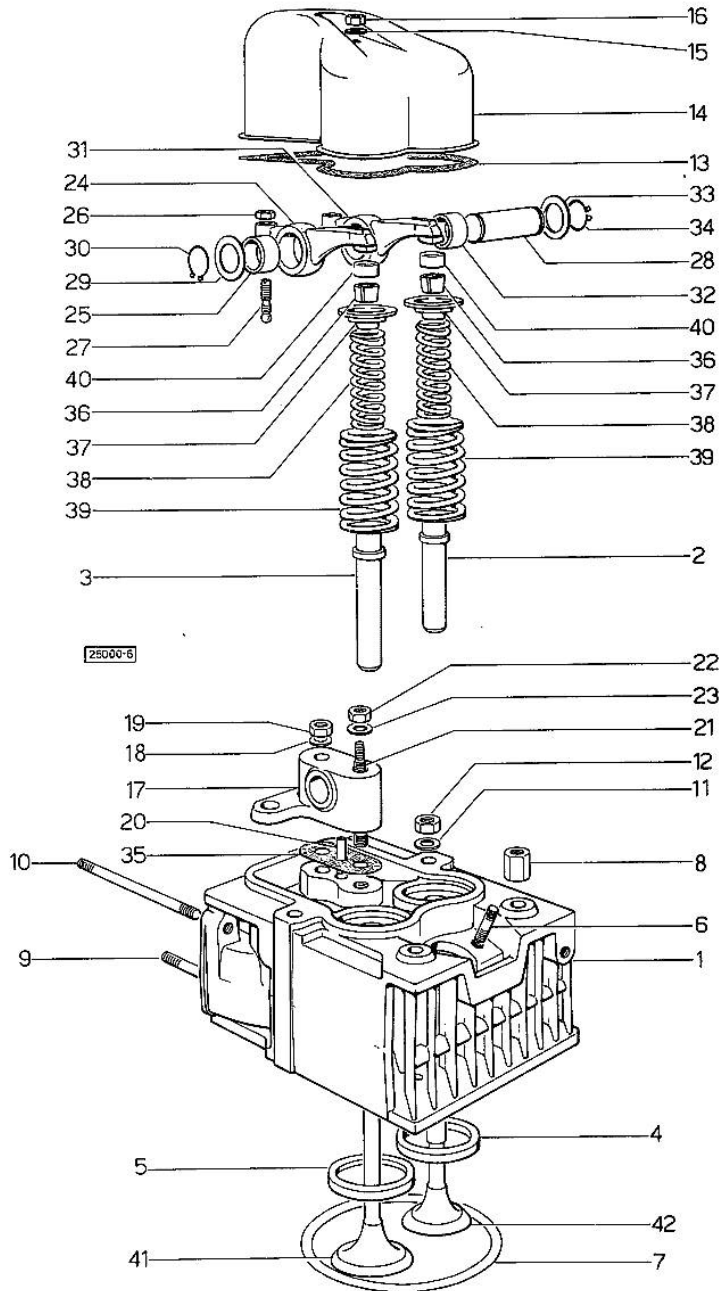

Fig.	P/n	QTY	Name
39	2.4019.193.0	8	spring 36.15x55.2x3.2
40	0.021.1453.0/20	8	small cover
41	0.062.1420.0	4	old part number
42	0.062.1421.0	4	old part number

Section: ENGINE
LUBRICATION

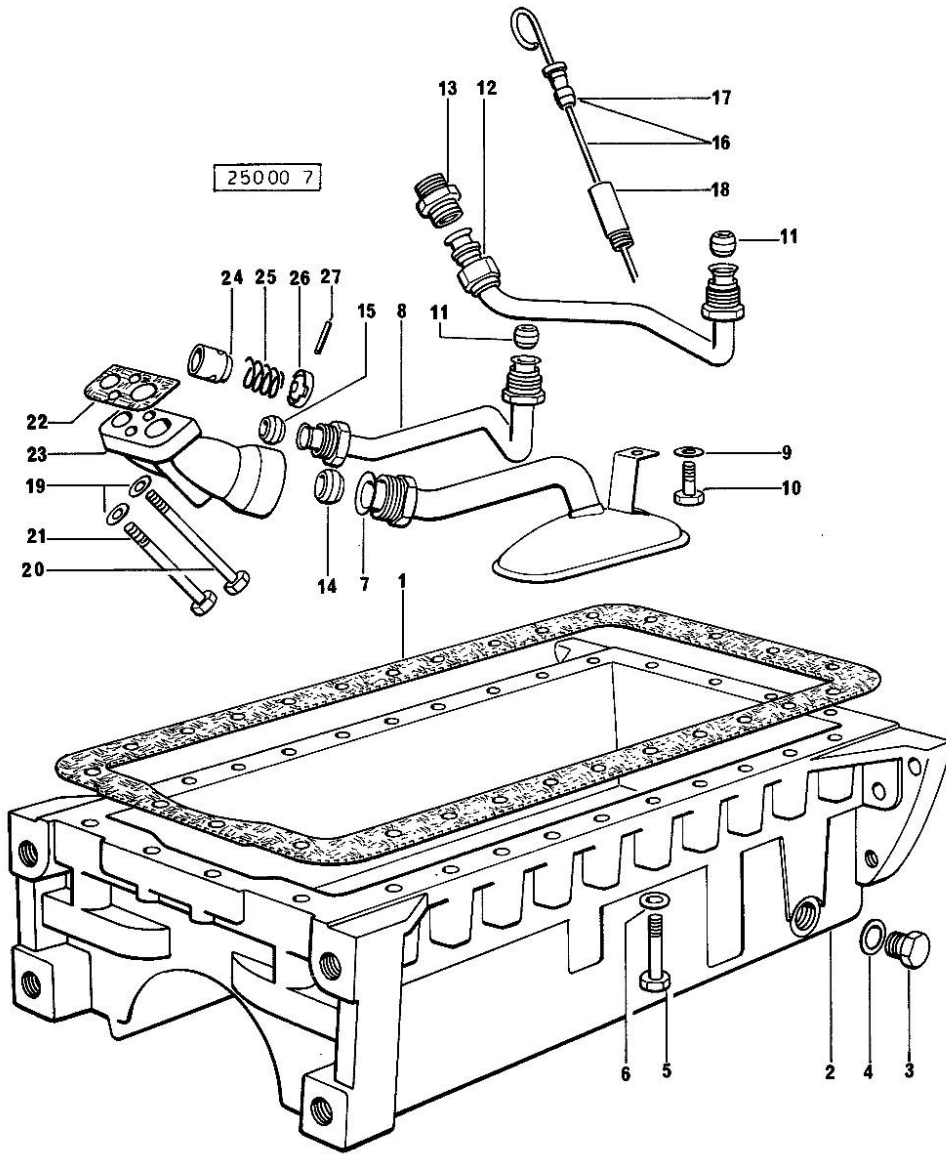

Fig.	P/n	QTY	Name
------	-----	-----	------

Notes:
[LEOPARD 90 Turbo]

1	0.036.1512.0	1	gasket
2	0.045.1559.0	1	oil sump
3	2.3199.001.2	1	plug 1/2" gas
4	2.1560.054.0	1	gasket 21 x 26
5	2.0112.217.2	2	screw m 8 p.1.25 x 45
5	2.0112.224.2	20	screw m 8 p.1.25x75
5	2.0112.231.1	2	screw m 8 p 1.25x110
5	2.0112.237.2	4	screw m 8 p.1.25x140
6	2.1560.004.0	4	copper gasket 8.2 x 14
7	0.044.1556.3/10	1	tube
8	0.044.1560.2	1	tube
9	2.1310.004.2	1	flat washer 8.4x17
10	2.0112.204.2	1	screw m 8 p.1.25x14
11	2.3359.015.1	2	nosepiece
12	0.044.1561.2/10	1	tube
13	0.045.1557.0	1	pipe fitting
14	2.3359.014.1	1	nosepiece
15	2.3359.016.1	1	nosepiece
16	0.045.1513.3	1	dipstick
17	0.034.1551.0	1	gasket
18	0.044.1555.0	1	spacer
19	2.1474.009.1	2	spring washer 8
20	2.0112.231.1	1	screw m 8 p 1.25x110
21	2.0112.225.2	1	screw m 8 p.1.25 x 80
22	0.037.1557.0/20	1	gasket
23	0.052.1530.0	1	tip
24	0.054.1557.0	1	small piston
25	2.4019.229.1	1	spring
26	0.054.1558.0	1	stop
27	2.1630.213.0	1	roll pin 3x32

<https://www.ebooklibonline.com>

Hello dear friend!

Thank you very much for reading.

Enter the link into your browser.

The full manual is available for immediate download.

<https://www.ebooklibonline.com>