

ENGINE

Fig.	P/n	QTY	Name
------	-----	-----	------

Notes:

[LASER 150 -> 10001]

1	6.N6303.00.0	1	engine ON ORDERING PLEASE ENGINE NO. REQUIRED
---	--------------	---	---

9_MOT00_00_M-A-001

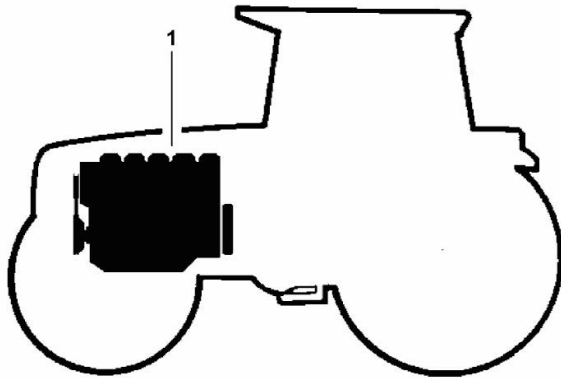

CRANKCASE

Fig.	P/n	QTY	Name
------	-----	-----	------

Notes:

[LASER 150 -> 10001]

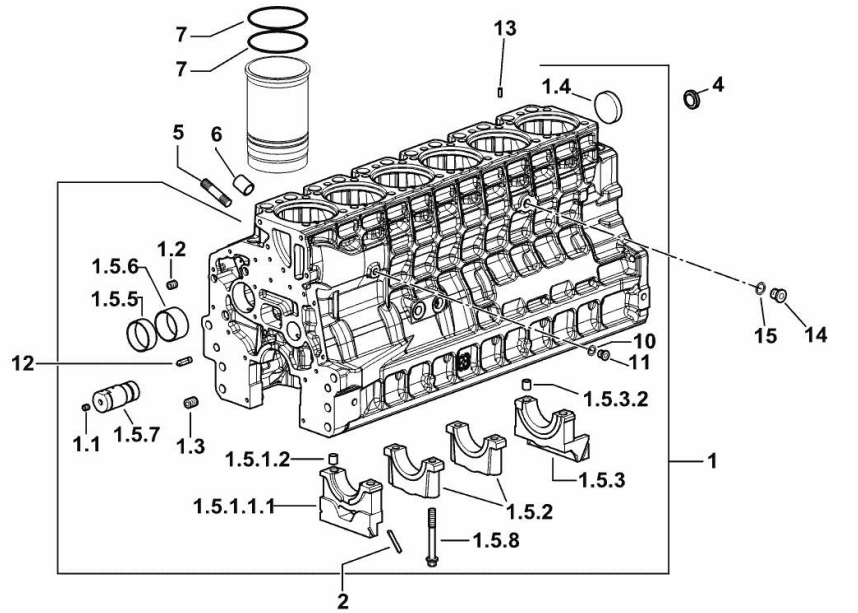

9_N6311_00_0-A-001

1	0.015.3558.4/10	1	crankcase
1.1	2.3130.001.1	20	plug 1/8" gas
1.2	2.3130.002.1	4	plug 1/4" gas
1.3	2.3130.003.1	6	plug 3/8" gas
1.4	2.3179.012.0	1	plug 60
1.5.1.1.1	0.065.1112.7/10	1	support
1.5.1.2	2.1699.165.0	1	bush 12.3x15x16
1.5.2	0.065.1114.0/10	5	support
1.5.3	0.007.0848.3/20	1	support
1.5.3.2	2.1699.165.0	1	bush 12.3x15x16
1.5.5	0.065.1140.0	6	special bushing 59X55X20
1.5.6	0.065.1141.0	1	special bushing 59X55X30
1.5.7	0.014.1340.0/10	1	pin mm 85
1.5.8	0.065.1117.0	14	screw m 12 x 100
2	0.066.1152.0/10	4	gasket
4	2.3199.312.2/20	1	plug m 35x1.5x9.5
5	2.0439.279.7	12	stud bolt m 8 p.1 x 25
6	2.1559.188.2	6	bush 11.4 x 14 x16
7	2.1539.259.0	12	special oil seal 107.62x2.62
10	2.1560.010.0	1	gasket 14.2 x 20
11	2.3199.292.0	1	plug 1/4" gas
12	0.013.4946.0/10	1	sprayer nozzle
13	2.1549.154.2	6	bush 4.8x5.8x16
14	2.3120.101.0	1	plug m 18 p.1.5
15	2.1560.014.0	1	washer 18.2 x 24

MONOBLOC ENGINE-GEARBOX CONNECTING FLANGE

Fig.	P/n	QTY	Name
------	-----	-----	------

Notes:

[LASER 150 -> 10001]

1	2.3131.003.2	1	plug m 16 p.1.5
6	2.0439.250.7	1	stud bolt m 12 / m 10 x 30
7	0.011.9294.0/10	1	bush
8	0.007.0809.0/20	1	flange
9	2.0112.513.2	11	screw m 14 p.2 x 35
13	2.1651.911.0	2	cylindrical plug
15	2.0432.257.7	1	stud bolt m 12 p.1.75 - 1.25 x 30
16	2.0312.520.2	2	screw m 14 p.2x70

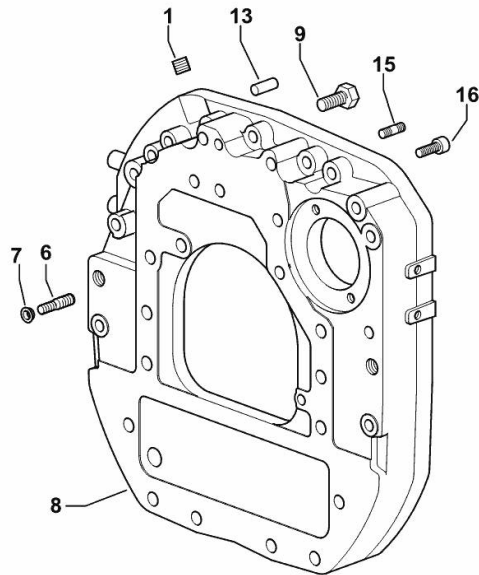

9_N0411_01_0-A-001

<https://www.ebooklibonline.com>

Hello dear friend!

Thank you very much for reading.

Enter the link into your browser.

The full manual is available for immediate download.

<https://www.ebooklibonline.com>

ENGINE OIL AND TURBO PRESSURE SWITCH UNION

Fig.	P/n	QTY	Name
------	-----	-----	------

Notes:

[LASER 150 -> 10001]

23	2.3339.673.0/10	1	pipe fitting
26	2.3110.403.1	1	plug m 14 p.1.5x12
27	2.1560.010.0	1	gasket 14.2 x 20
28	2.1019.129.2/10	1	nut m 18 p.1.5x12
29	2.1533.038.0	1	oil seal 15.45x2.62

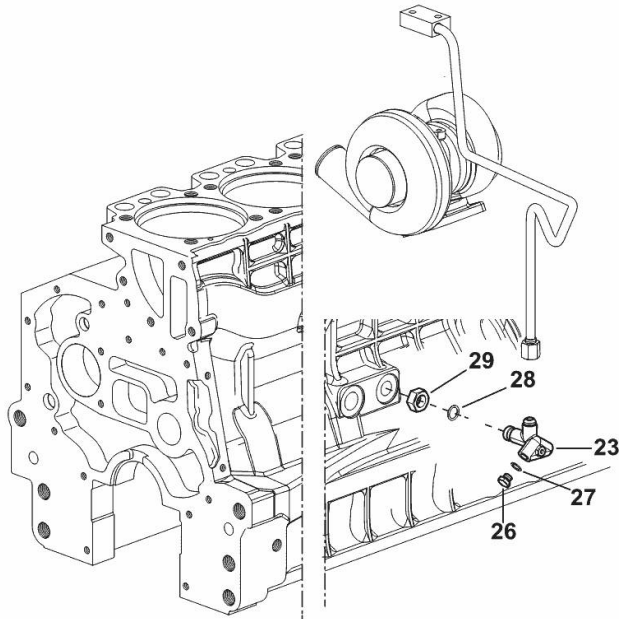

9_N6315_03_0-B-001

ENGINE LIFTING BRACKET

Fig.	P/n	QTY	Name
------	-----	-----	------

Notes:

[LASER 150 -> 10001]

31	2.1310.004.2	2	flat washer 8.4x17
32	2.0112.207.2	2	screw m 8 p 1.25 x 20
36	0.008.9433.0	1	bracket

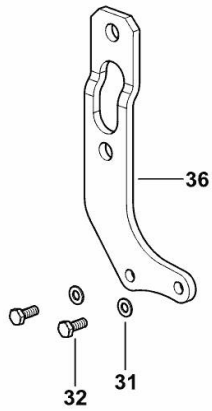

9_N6318_01_0-C-001

ENGINE FLYWHEEL

Fig.	P/n	QTY	Name
------	-----	-----	------

Notes:

[LASER 150 -> 10001]

1	0.078.1241.3	1	flywheel
1.2	0.065.1242.0	1	crown wheel Z = 123
2	0.288.3625.0	1	flange
3	2.0139.023.2	6	screw
4	2.1651.915.0	1	pin 12x35

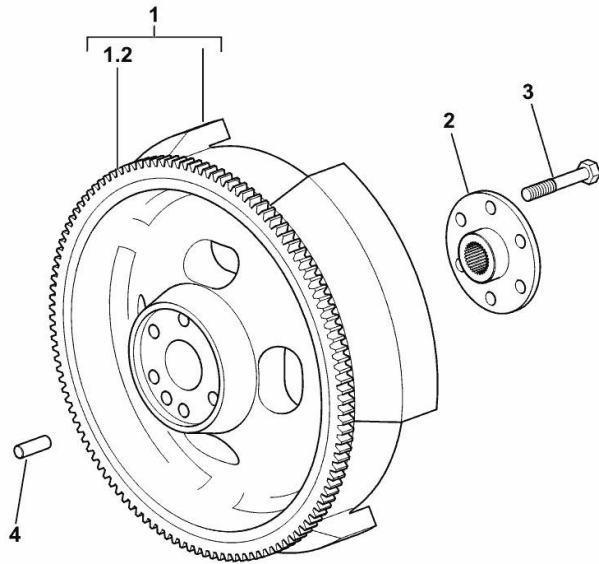

9_N0412_01_0-A-001

CRANKSHAFT

Fig.	P/n	QTY	Name
------	-----	-----	------

Notes:

[LASER 150 -> 10001]

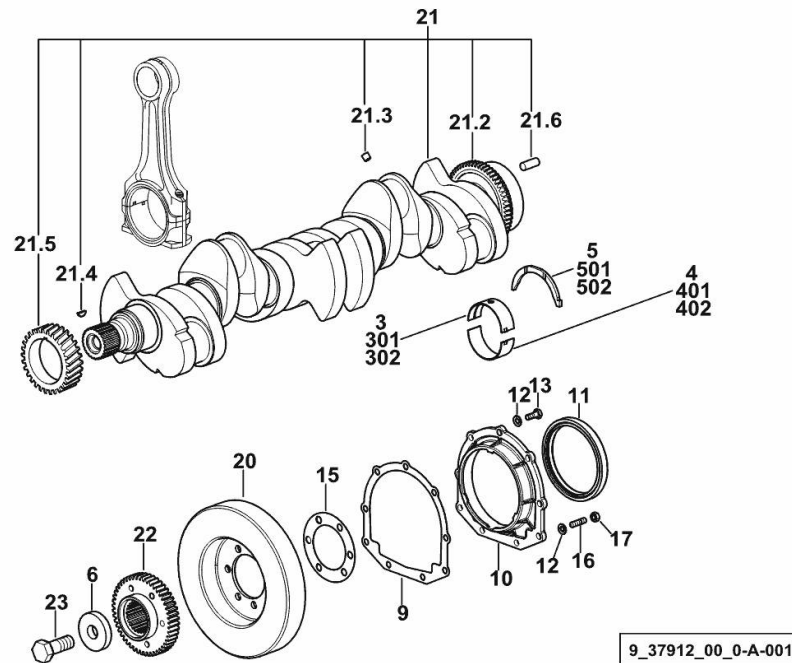

3	0.065.1215.0/10	7	main half bushing STANDARD
4	0.065.1216.0/10	7	main half bushing STANDARD
5	0.065.1218.0	4	shim STANDARD
6	2.1599.524.7	1	washer 21x60x12
9	0.065.1254.0/20	1	gasket
10	0.007.0851.0/10	1	cover
11	2.1529.073.0	1	special oil seal 110x130x13
12	2.1475.002.2	9	conical washer 8
13	2.0112.207.2	7	screw m 8 p 1.25 x 20
15	2.1589.137.0	2	shoulder ring 71x110x1
16	2.0432.003.7	2	stud bolt m 8 p.1.25 / p.1 x 20
17	2.1011.105.2	2	nut m 8 p.1.25
20	0.009.3704.3	1	antivibration pulley
21	0.010.4320.3/30	1	crankshaft
21.2	0.007.0855.0/10	1	gear
21.3	2.3130.001.1	6	plug 1/8" gas
21.4	2.1720.006.0	1	key 4x6.5
21.5	0.007.1188.0/30	1	gear Z = 29
21.6	2.1651.915.0	1	pin 12x35
22	0.011.2206.0/20	1	hub
23	2.0399.144.7/10	1	screw m 20 p.1.5x51
301	0.065.1215.7		main half bushing - mm 0.25
302	0.065.1215.8		main half bushing - mm 0.50
401	0.065.1216.7		main half bushing - mm 0.25
402	0.065.1216.8		main half bushing - mm 0.50
501	0.065.1218.7		shim + mm 0.10
502	0.065.1218.8		shim + mm 0.15

CRANKSHAFT PULLEY

Fig.	P/n	QTY	Name
------	-----	-----	------

Notes:

[LASER 150 -> 10001]

1	0.007.0962.0/30	1	pulley
2	2.0112.322.2	6	screw m 10 p.1.5x65
3	2.1470.006.2	6	lock washer 10

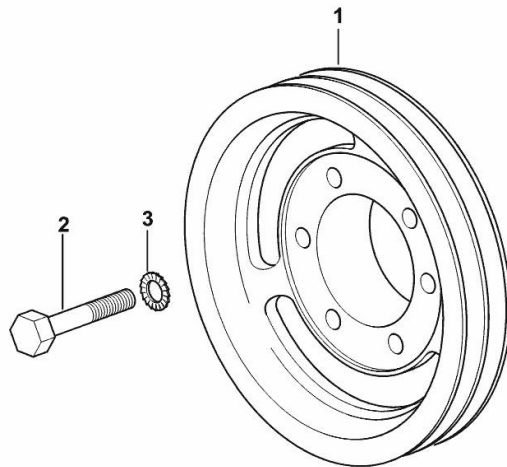

9_33712_01_0-A-001

COOLANT PUMP AND ALTERNATOR DRIVEBELT

Fig.	P/n	QTY	Name
------	-----	-----	------

Notes:

[LASER 150 -> 10001]

1	2.4119.099.0	2	belt AV 13x1437 mm
---	--------------	---	--------------------

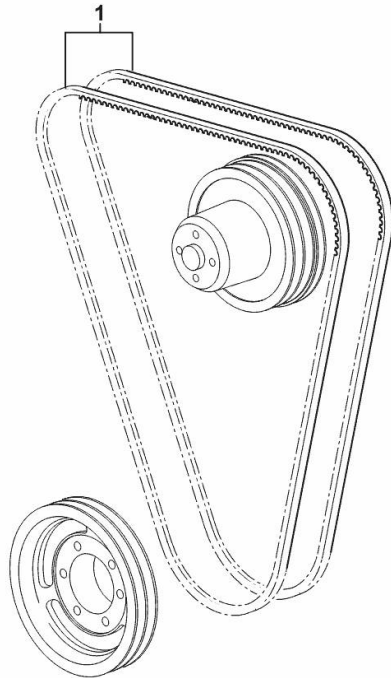

9_33717_01_0-A-001

COOLANT PUMP AND ALTERNATOR DRIVEBELT

Fig.	P/n	QTY	Name
------	-----	-----	------

Notes:

- FOR MODELS WITH COMPRESSOR [LASER 150 -> 10001]

1	0.007.0967.0	2	belt AV 12.7x1470 mm
2	2.4119.134.0	1	belt AV 10x794 mm

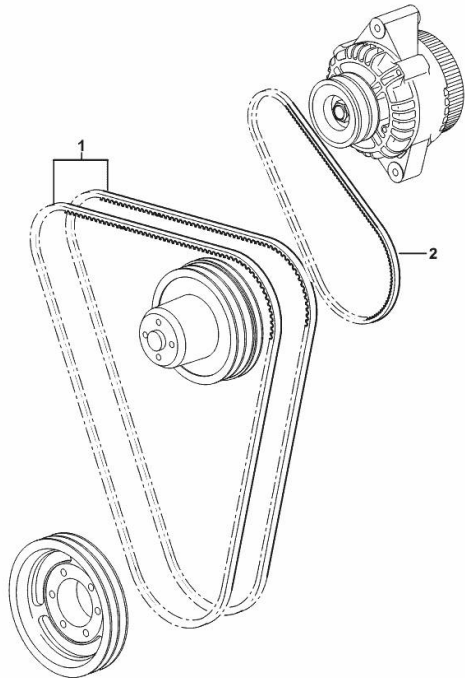

9_M9917_02_0-A-001

CYLINDER - PISTON - CONNECTING ROD

Fig.	P/n	QTY	Name
------	-----	-----	------

Notes:

1162 <= [LASER 150 -> 10001]

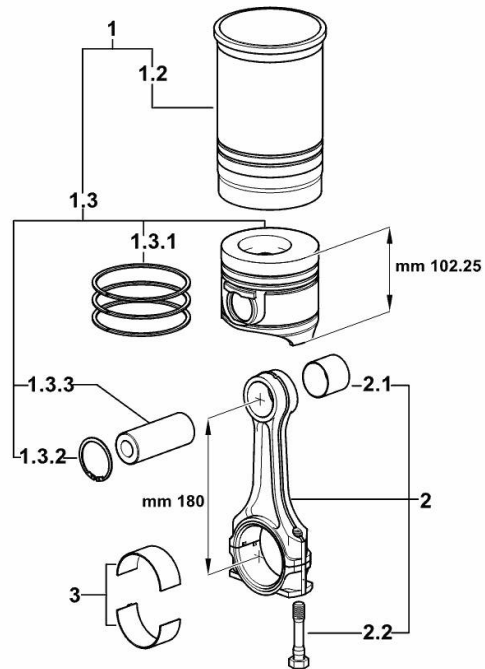

9_N6312_02_M-A-001

1	0.050.0065.A	6	cyl. piston assembly "A" - CLASS A
1	0.050.0065.B	6	cyl. piston assembly "B" - CLASS B
1.2	0.A12.2675.0	1	engine cylinder "A" - CLASS A
1.2	0.B12.2675.0	1	engine cylinder "B" - CLASS B
1.3	0.050.0060.A	1	complete piston "A" - CLASS A
1.3	0.050.0060.B	1	complete piston "B" - CLASS B
1.3.1	0.338.0052.6/20	1	piston ring set
1.3.2	2.1411.014.1	2	circlip 35
1.3.3	0.038.1236.0/10	1	piston pin Ø 18 / Ø 35 / L = mm 90
2	0.007.1395.3/20	6	engine connecting rod
2.1	2.1559.255.0	1	special bushing 34.60x39.130x34.65
2.2	2.0399.213.0	2	screw m 12 p.1.25x61.5
3	0.065.1225.0	12	con.rod half bushing STANDARD - A = 28.75 -> 29.00
3	0.065.1225.7	12	con.rod half bushing - mm 0.25
3	0.065.1225.8	12	con.rod half bushing - mm 0.50

CYLINDER - PISTON - CONNECTING ROD

Fig.	P/n	QTY	Name
------	-----	-----	------

Notes:

=> 1163 [LASER 150 -> 10001]

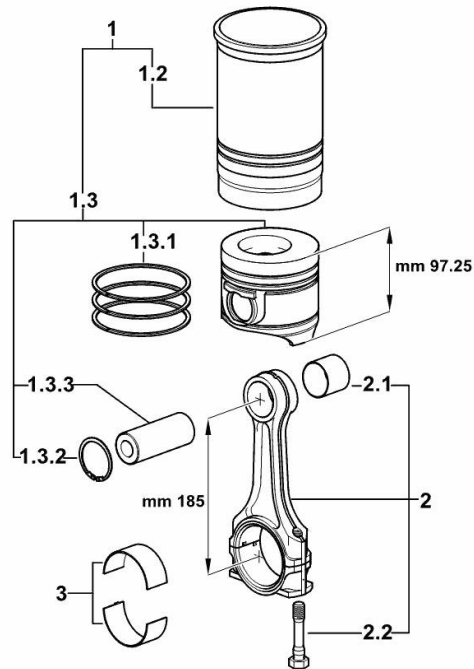

1	0.O55.0065.A	6	cyl. piston assembly "A" - CLASS A
1	0.O55.0065.B	6	cyl. piston assembly "B" - CLASS B
1.2	0.A12.2675.0	1	engine cylinder "A" - CLASS A
1.2	0.B12.2675.0	1	engine cylinder "B" - CLASS B
1.3	0.O55.0060.A	1	complete piston "A" - CLASS A
1.3	0.O55.0060.B	1	complete piston "B" - CLASS B
1.3.1	0.338.0052.6/20	1	piston ring set
1.3.2	2.1411.014.1	2	circlip 35
1.3.3	0.078.1236.0	1	piston pin Ø 18 / Ø 35 / L = mm 86
2	0.014.5175.3	6	engine connecting rod
2.1	2.1559.255.0	1	special bushing 34.60x39.130x34.65
2.2	2.0399.213.0	2	screw m 12 p.1.25x61.5
3	0.065.1225.0	12	con.rod half bushing STANDARD - A = 28.75 -> 29.00
3	0.065.1225.7	12	con.rod half bushing - mm 0.25
3	0.065.1225.8	12	con.rod half bushing - mm 0.50

9_Q7512_01_M-A-001

CAMSHAFT

Fig.	P/n	QTY	Name
------	-----	-----	------

Notes:

[LASER 150 -> 10001]

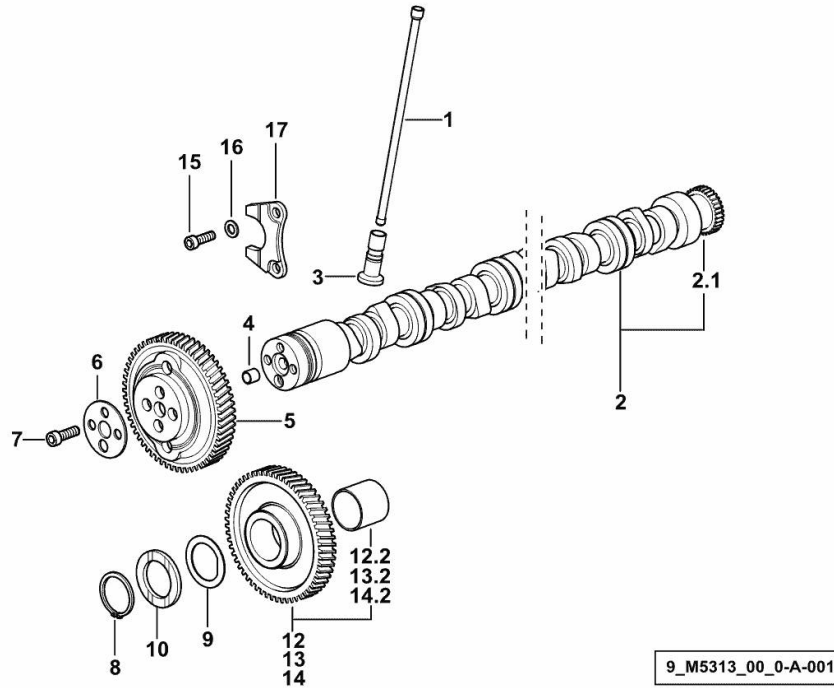

1	0.065.1331.2	12	rod
2	0.013.1647.3/10	1	camshaft
2.1	0.065.1324.0/10	1	gear Z = 32
3	0.065.1330.0	12	tappets
4	2.1559.398.0	1	bushing 10.5x13x12
5	0.013.5017.0	1	gear z=58
6	0.065.1350.0	1	small disc
7	2.0132.207.2	4	screw m 10 p.1 x 25
8	2.1410.016.1	1	circlip 40
9	0.065.1352.0	1	shim
10	0.018.2233.0	2	shoulder ring
12	0.007.1177.3/20	0.5	gear z = 57 - WITH RED IDENTIFICATION STAMP
12.2	2.1559.185.0/10	1	bushing
13	0.007.1178.3/20	0.5	gear z = 57 - WITH YELLOW IDENTIFICATION STAMP
13.2	2.1559.185.0/10	1	bushing
14	0.007.1179.3/20		gear z = 57 - WITH GREEN IDENTIFICATION STAMP
14.2	2.1559.185.0/10	1	bushing
15	2.0312.205.2	2	screw
16	2.1480.014.1	2	washer 8
17	0.065.1353.0	1	small plate



Suggest:

For more complete manuals. Please go to the home page.

<https://www.ebooklibonline.com>

If the above button click is invalid. Please download this document first, and then click the above link to download the complete manual.

Thank you so much for reading

GUARD PLATE

Fig.	P/n	QTY	Name
------	-----	-----	------

Notes:

[LASER 150 -> 10001]

1	0.007.1262.3/50	1	guard
2	0.007.1271.0/10	1	small column m 8 p.1.25 / L = mm 60
3	0.007.1272.0/10	2	small column m 8 p.1.25 / L = mm 50
5	2.1310.004.2	3	flat washer 8.4x17
7	2.0112.203.2	3	screw m 8 p.1.25 x 12

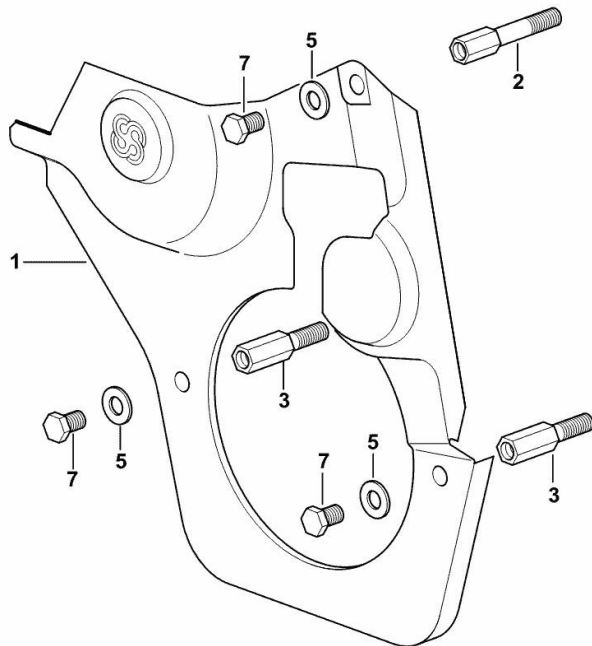

9_33011_02_0-A-001

TIMING CASE

Fig.	P/n	QTY	Name
------	-----	-----	------

Notes:

[LASER 150 -> 10001]

1	0.013.4981.0	1	guard
11	0.065.1150.0/30	1	gasket
12	2.0432.003.7	2	stud bolt m 8 p.1.25 / p.1 x 20
13	2.0312.219.2	4	screw m 8 p.1.25x65
14	2.1480.014.1	15	washer 8
15	2.1470.004.2	4	lock washer 8
16	2.1011.405.2	2	nut m 8 p.1
17	2.1529.167.0	1	oil seal
18	2.0312.214.2	3	screw m 8 p.1.25 x 40
19	2.0312.208.2	8	screw m 8 p.1.25 x 25

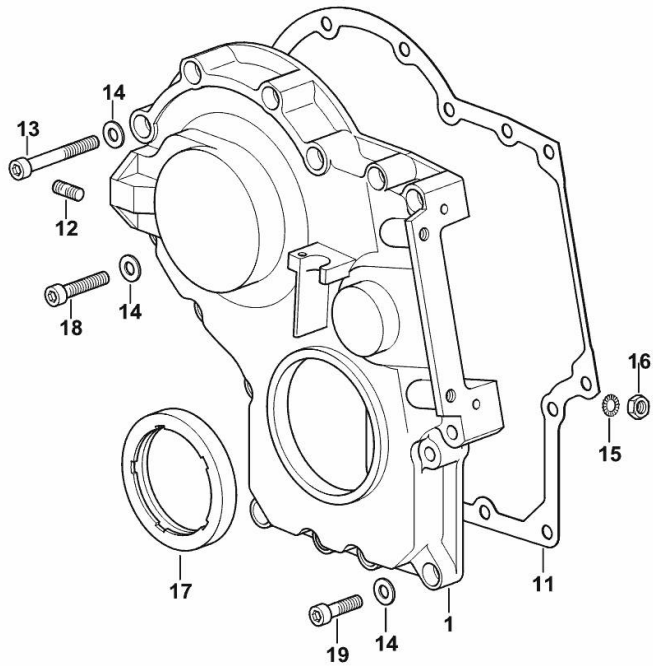

9_M3711_01_0-A-001

<https://www.ebooklibonline.com>

Hello dear friend!

Thank you very much for reading.

Enter the link into your browser.

The full manual is available for immediate download.

<https://www.ebooklibonline.com>