

Section: ENGINE
CRANKCASE

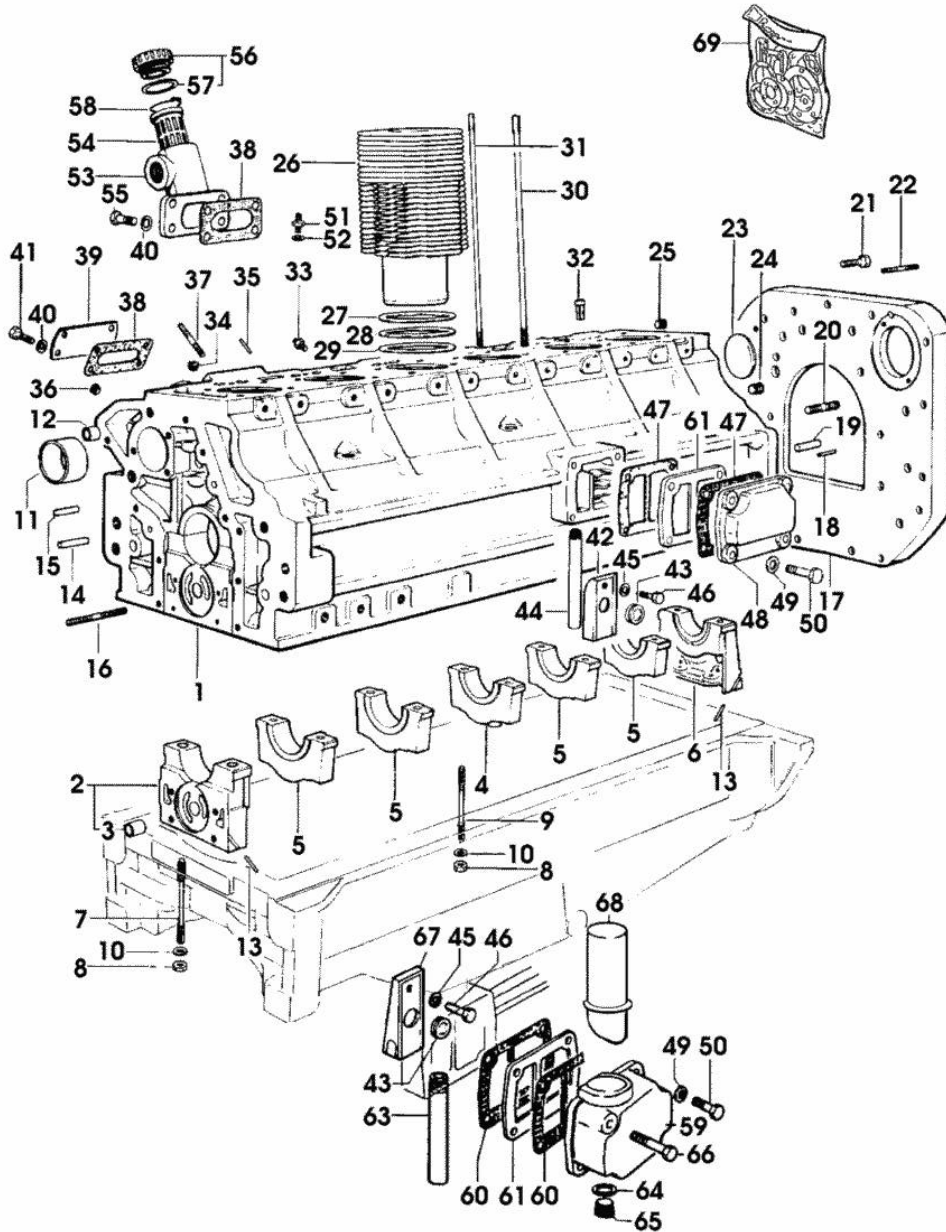

Fig.	P/n	QTY	Name
Notes: [LASER 130]			
1	0.047.1110.4/80	1	crankcase * 10564 <= X 110HP * 20306 <= X 130HP - N.1 045.1240.0 - N.2 2.0112.309.2 - N.2 2.1474.010.0
1	0.047.1150.4/20	1	crankcase - EXPORT U.S.A. * 10564 <= X 110HP - N.1 045.1240.0 - N.2 2.0112.309.2 - N.2 2.1474.010.0 * => 10565 - (...) <= X 110HP - N.1 071.1153.0 - N.1 071.1154.0 - N.1 044.1153.0/10 - N.1 071.1156.0 - N.1 071.1155.2 - N.4 2.0112.211.2 * (...) <= X 130
2	0.004.8774.3	1	support
3	2.1559.090.0/10	1	bushing 14.24x19.06x27
4	0.037.1114.0	2	support
5	0.029.1113.0	3	support
6	0.029.1116.0	1	support
7	0.021.1157.0	4	stud bolt
8	2.1019.026.7	14	special nut m 12 p.1.5
9	0.029.1117.0	10	stud bolt
10	2.1599.144.7	14	shoulder ring 12.5x23x4
11	0.037.1155.0	1	bushing
12	2.1559.111.0/10	2	special bushing 11.5x14.1x10 - EXPORT U.S.A.
12	2.1559.149.0	1	special bushing
13	0.029.1154.0/10	4	gasket
14	2.1699.114.0	1	pin 8x55
15	2.1651.711.0	1	pin 8 x 14
16	2.0432.025.7	2	stud bolt m 8 p.1.25 - 1.00 x 100
17	0.071.1150.0	1	flange
18	2.1653.708.0	2	pin 8x18 20306 <= X 130HP 10564 <= X 110HP
19	2.1651.911.0	2	cylindrical plug
20	2.0432.153.7	2	stud bolt m 10 p.1.5 / p.1.25 x 20
21	2.0112.513.2	11	screw m 14 p.2 x 35
22	2.0432.257.7	2	stud bolt m 12 p.1.75 - 1.25 x 30
23	2.3170.022.1	1	expansion plug 60
24	2.3130.003.1	2	plug 3/8" gas
25	2.3130.002.1	1	plug 1/4" gas
26	0.044.1120.0/40	6	engine cylinder

258_002

Section: ENGINE
CRANKCASE

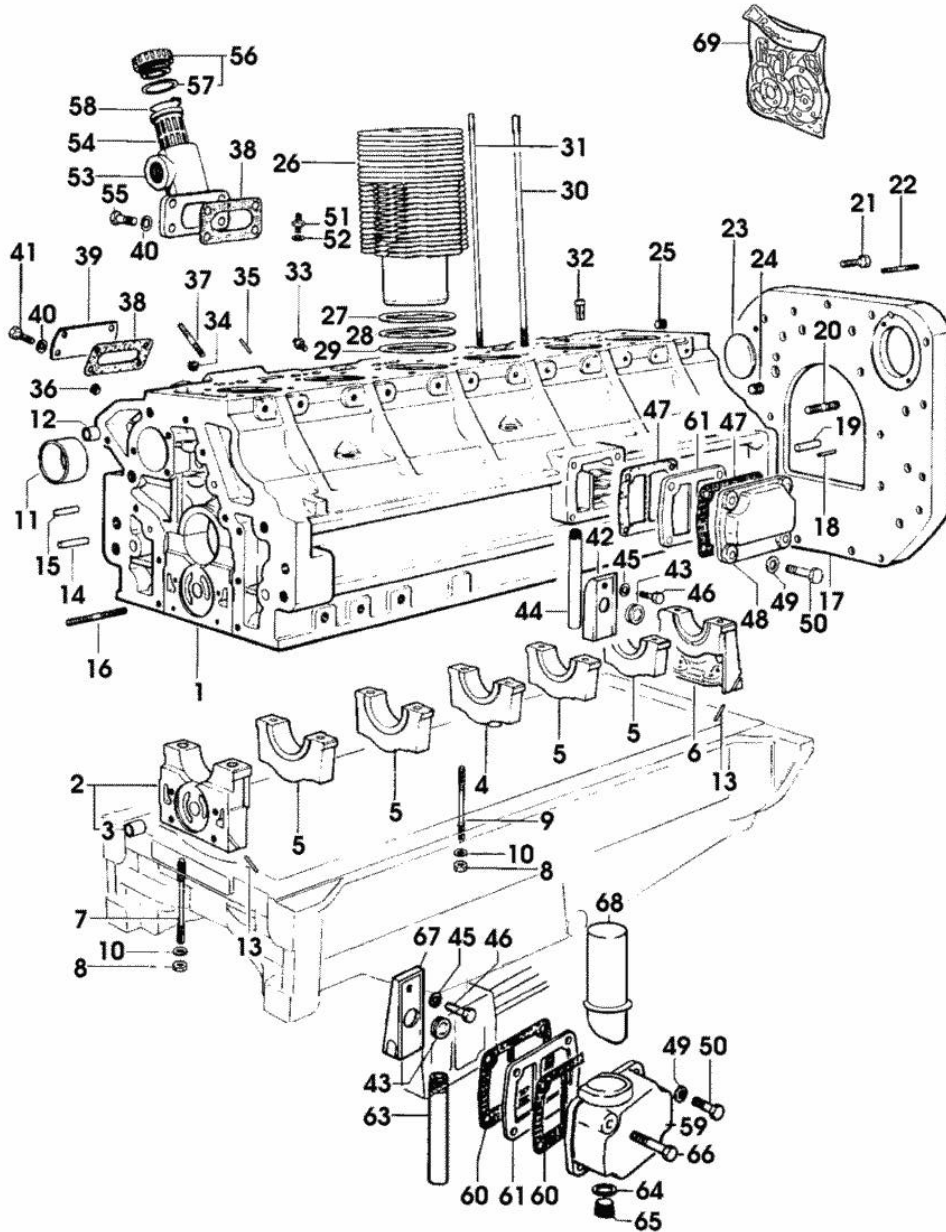

Fig.	P/n	QTY	Name
			- X 130HP
26	0.063.1120.0/30	6	engine cylinder
			- X 110HP
27	2.1589.052.0	12	shoulder ring 115x123x0.2
28	2.1589.051.0	6	shoulder ring 116x123x0.1
29	2.1569.076.0	6	gasket 116x123x0.5
30	0.039.1122.0	24	stud bolt m 12 p.1.5x310
31	0.041.1123.0/10	6	stud bolt
32	0.044.1156.0	12	special bushing
33	0.071.1151.3/10	6	valve
34	2.3130.001.1	3	plug 1/8" gas
35	2.1651.306.0	2	cylindrical plug
36	2.3139.001.1	6	plug
37	2.0432.003.7	8	stud bolt m 8 p.1.25 / p.1 x 20
38	0.044.1151.0	2	gasket
39	0.044.1164.2/10	1	small cover
40	2.1310.004.2	8	flat washer 8.4x17
41	2.0112.205.2	1	screw m 8 p.1.25 x 16
41	2.0112.209.2	3	screw m 8 p 1.25 x 25
42	0.044.1155.2/20	1	cover (...) <=
43	0.071.1156.0	1	special oil seal
44	0.044.1152.0/10	1	tube (...) <=
45	2.1480.014.1	2	washer 8
46	2.0312.206.2	1	screw m 8 p 1.25 x 20
47	0.044.1153.0/10	1	gasket (...) <=
48	0.044.1154.0	1	cover (...) <=
48	0.071.1154.0	1	small cover => (...) - (...) <=
49	2.1480.014.1	4	washer 8
50	2.0112.209.2	1	screw m 8 p 1.25 x 25
50	2.0112.211.2	3	screw m 8 p.1.25 x 30
51	0.054.1150.0	2	pipe fitting
52	2.1560.006.0	2	gasket 10.2 x 16
53	0.045.1153.0	1	flange
54	0.041.1159.0/10	1	filter
55	2.0112.205.2	1	screw m 8 p.1.25 x 16
55	2.0112.209.2	4	screw m 8 p 1.25 x 25
56	0.041.1135.4	1	plug 1" gas
57	2.1569.072.0	1	gasket 32 x 39.5 x 2
58	2.1411.012.1	1	circlip 30

258_002

Section: ENGINE
CRANKCASE

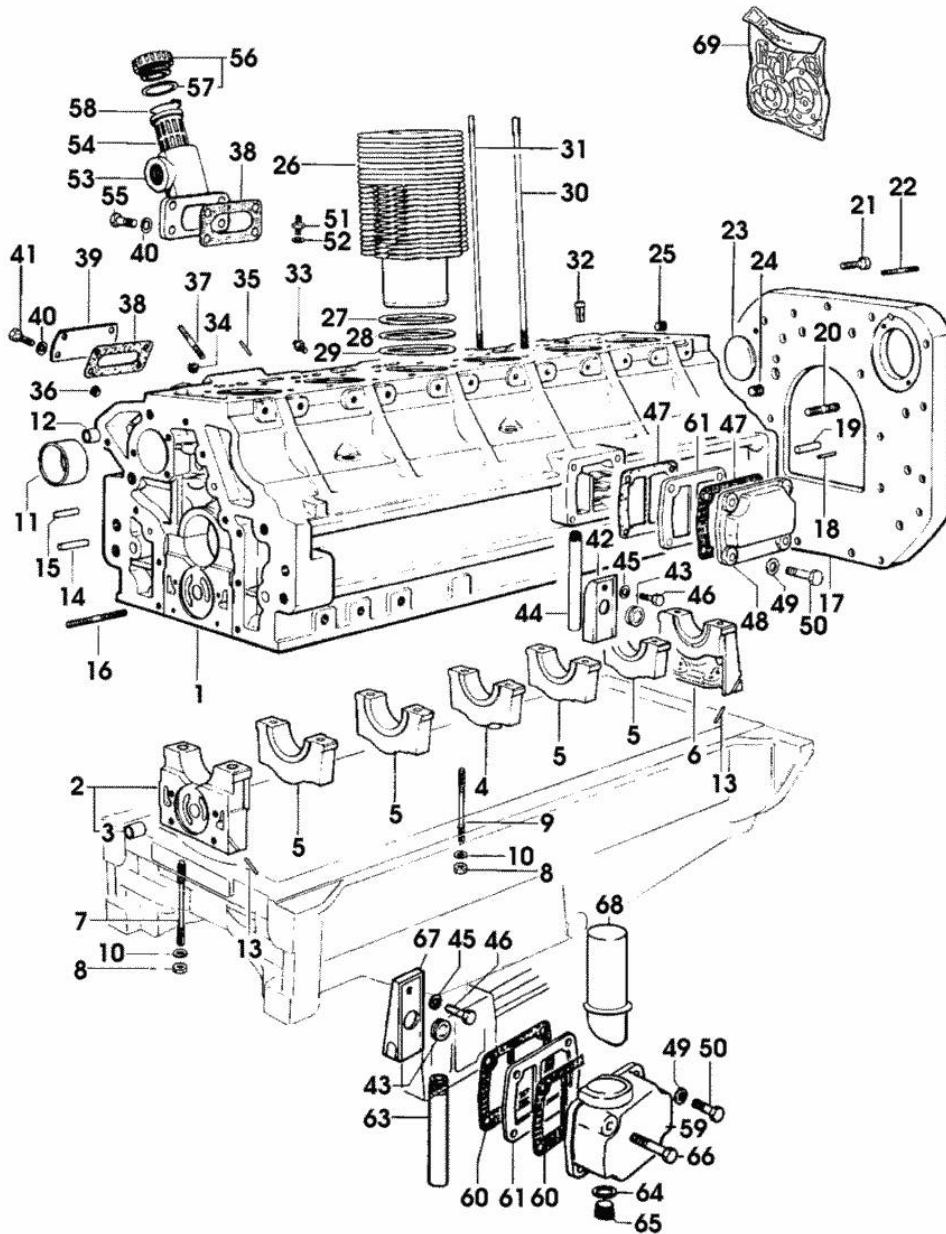

Fig.	P/n	QTY	Name
59	0.074.1153.0	1	flange => (...)
60	0.044.1153.0/10	2	gasket => (...)
61	0.071.1153.0	1	small cover => (...)
63	0.074.1155.2	1	tube => (...)
64	2.1560.055.0	1	gasket 27.3x31.9 => (...)
65	2.3130.004.1	1	plug 1/2 gas => (...)
66	2.0112.225.2	1	screw m 8 p.1.25 x 80 => (...)
67	0.071.1155.2	1	small guard => (...)
68	0.074.1154.2	1	tube => (...)
69	0.072.0050.6	1	gasket set - X 110HP
69	0.073.0050.6	1	gasket set - X 130HP - FOR ENGINE MOUNTING

258_002

<https://www.ebooklibonline.com>

Hello dear friend!

Thank you very much for reading.

Enter the link into your browser.

The full manual is available for immediate download.

<https://www.ebooklibonline.com>

Section: ENGINE
TIMING CASE

Fig.	P/n	QTY	Name
------	-----	-----	------

Notes:
[LASER 130]

1	0.048.1131.0	1	flange
2	0.041.1153.0/10	1	gasket
3	2.0112.209.2	2	screw m 8 p 1.25 x 25
4	2.1470.009.2	2	lock washer 16
5	2.0119.034.1	1	screw m 14 p.2x20
6	2.1560.010.0	1	gasket 14.2 x 20
7	2.0112.207.2	1	screw m 8 p 1.25 x 20
8	2.1470.009.2	1	lock washer 16
9	0.041.1152.0/10	1	gasket
10	2.1519.010.0	1	special oil seal 58x80x10
11	0.048.1132.0/40	1	guard
12	2.0112.219.2	5	screw m 8 p.1.25x55
13	2.1470.009.2	5	lock washer 16
14	2.1560.003.0	2	copper gasket 8.2 x 12
15	2.1011.405.2	2	nut m 8 p.1
16	2.1470.009.2	5	lock washer 16
17	2.0112.211.2	5	screw m 8 p.1.25 x 30
18	2.0112.223.2	4	screw m 8 p.1.25x70
19	2.1470.009.2	4	lock washer 16
20	0.041.1158.0	1	index
21	2.1310.004.2	1	flat washer 8.4x17
22	2.0112.205.2	1	screw m 8 p.1.25 x 16
23	0.048.1151.0/10	1	gasket
24	0.048.1150.0/20	1	cover
25	2.1560.006.0	4	gasket 10.2 x 16
26	2.0112.315.2	4	screw m 10 p.1.5 x 40
27	0.041.1154.0	1	gasket
28	2.0432.015.7	1	stud bolt m 8 p.1.25-1x50
29	2.0432.028.7	3	stud bolt m 8 p.1.25-1x130
30	2.1653.717.0	1	pin 8 x 40
31	0.041.1135.4	1	plug 1" gas
32	2.1569.072.0	1	gasket 32 x 39.5 x 2
33	0.037.1151.0/10	1	cover
35	2.1310.004.2	4	flat washer 8.4x17
36	2.0112.235.2	1	screw m 8 p.1.25 x 130
37	2.1011.505.2	3	nut m 8 p.1
38	2.1411.012.1	1	circlip 30
39	0.041.1159.0/10	1	filter
40	2.0112.209.2	2	screw m 8 p 1.25 x 25

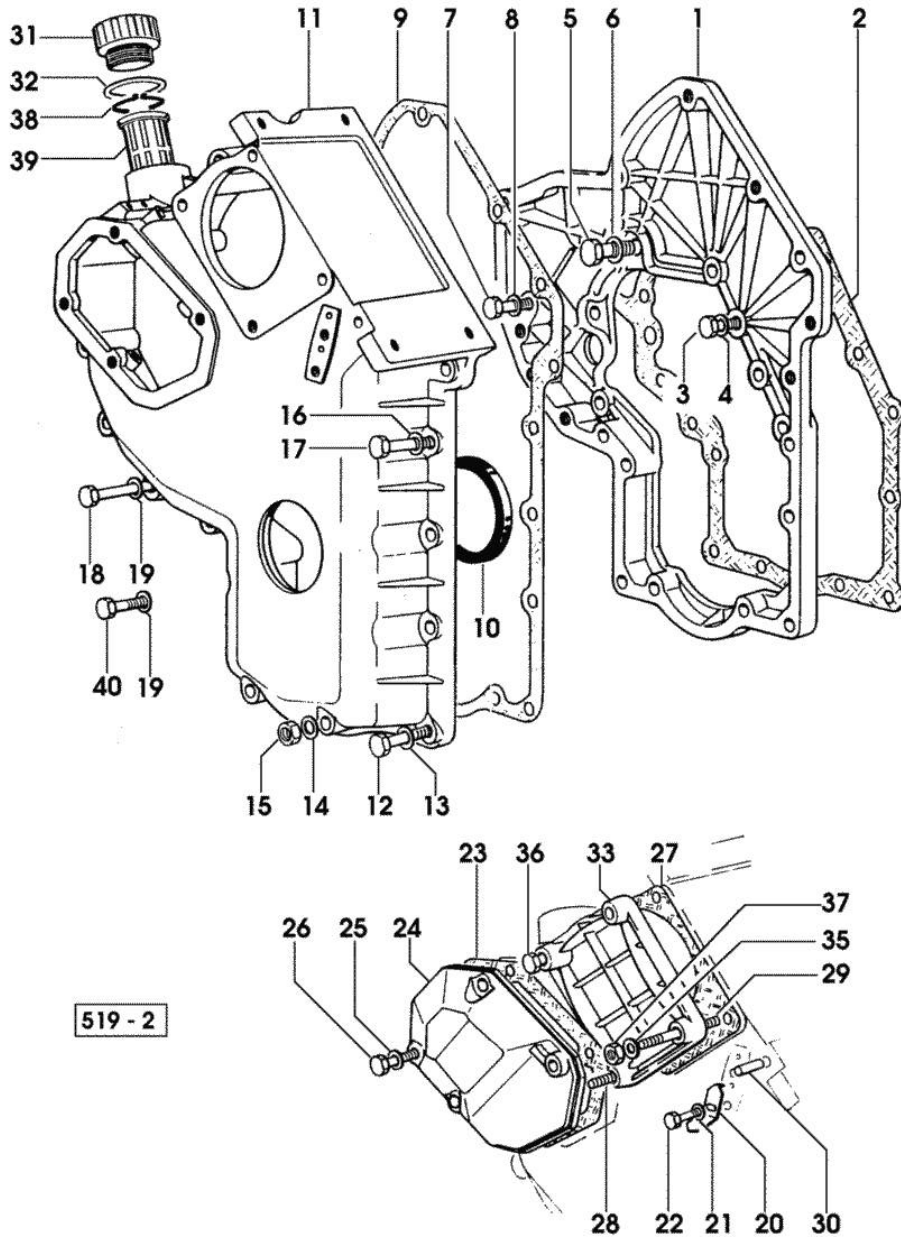

Section: ENGINE

CRANKSHAFT

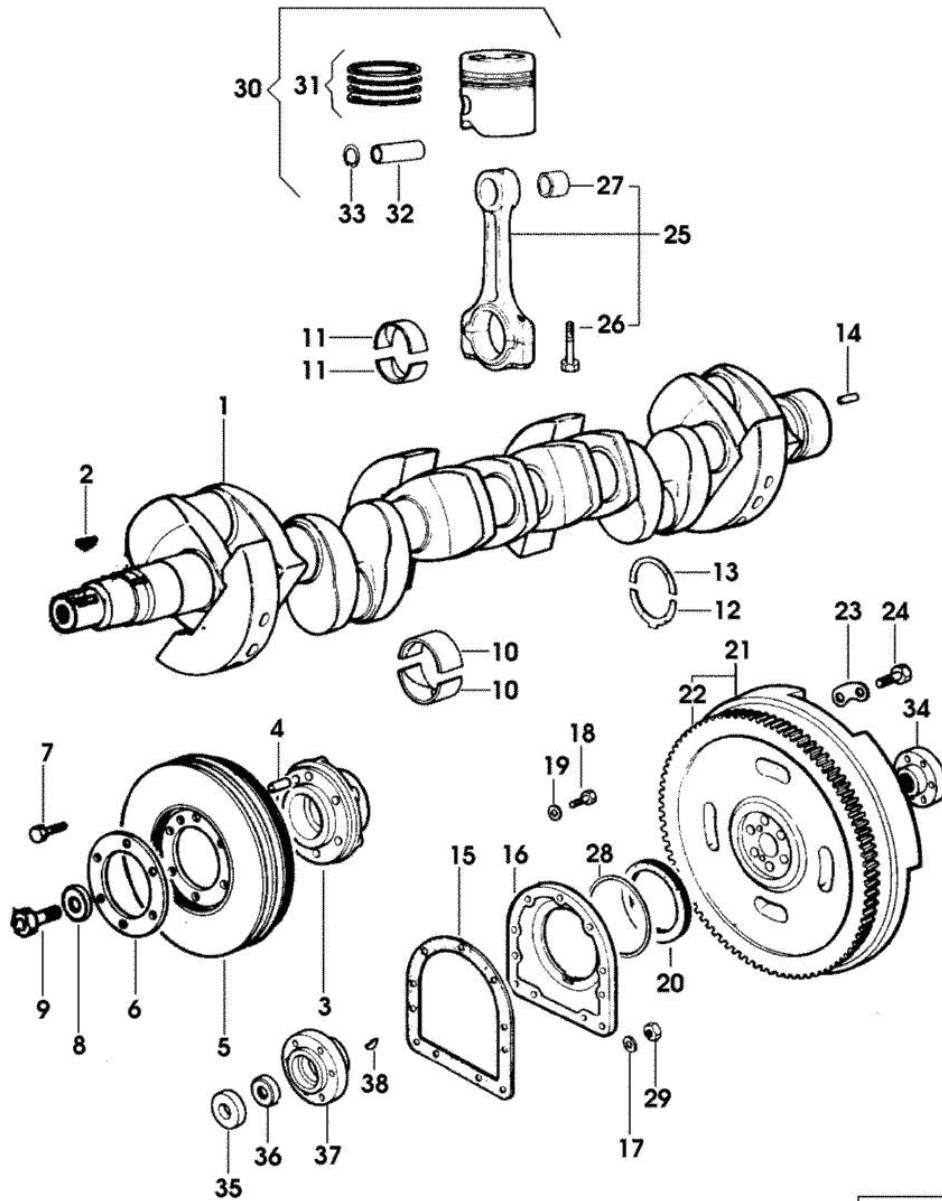

258_006

Fig.	P/n	QTY	Name
Notes:			
[LASER 130]			
1	0.037.1210.4/30	1	crankshaft * 10975 <= X 110HP * 20585 <= X 130HP * 10407 <= X 150HP - N 1 2.1799.026.0
2	2.1799.002.0	1	stick 10x13 10975 <= X 110HP 20585 <= X 130HP 10407 <= X 150HP
2	2.1799.026.0	1	key 10x10 => 10976 X 110HP => 20586 X 130HP => 10408 X 150HP
3	0.037.1250.0/10	1	hub
4	2.1651.909.0	1	cylindrical plug 12 x 20
5	0.046.1246.3	1	antivibration pulley - X 110HP - X 130HP
5	0.071.1246.3/10	1	antivibration pulley - X 150HP
6	0.037.1255.0	1	flange
7	2.0122.461.1	6	screw m 12 p.1.25x30
8	0.001.6020.0	1	shoulder
9	2.0129.032.2	1	screw m 24 p.2x45
10	0.073.0059.0		main half bushing - mm 1.00
10	0.073.1215.0	14	main half bushing STANDARD
10	0.073.1215.7		main half bushing - mm 0.25
10	0.073.1215.8		main half bushing - mm 0.50
10	0.073.1215.9		main half bushing - mm 0.75
11	0.062.0059.0		con.rod half bushing - mm 1.00
11	0.062.1225.0	12	con.rod half bushing STANDARD
11	0.062.1225.7		con.rod half bushing - mm 0.25
11	0.062.1225.8		con.rod half bushing - mm 0.50
11	0.062.1225.9		con.rod half bushing - mm 0.75
12	0.001.4547.0		shoulder ring + mm 0.05
12	0.001.4548.0		shoulder ring + mm 0.10
12	0.001.4549.0		shoulder ring + mm 0.15
12	0.042.1219.0	2	shoulder ring STANDARD
13	0.001.4544.0		shoulder ring + mm 0.05
13	0.001.4545.0		shoulder ring + mm 0.10
13	0.001.4546.0		shoulder ring + mm 0.15

Section: ENGINE

CRANKSHAFT

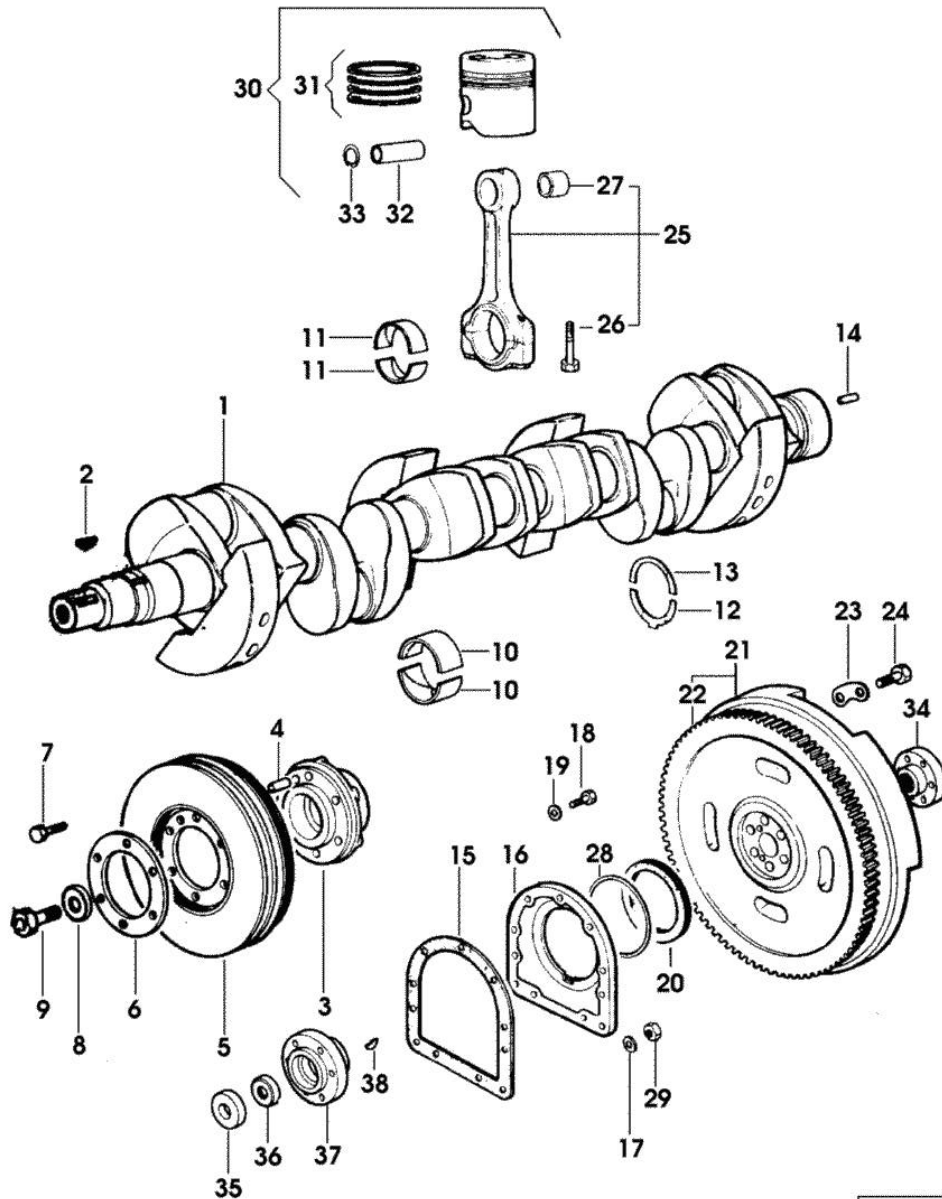

258_006

Fig.	P/n	QTY	Name
13	0.042.1218.0	2	shoulder ring STANDARD
14	2.1652.915.0	2	cylindrical plug 12x35
15	0.029.1250.0/10	1	gasket
16	0.029.1240.0/10	1	flange
			10564 <= X 110HP
			20306 <= X 130HP
			10173 <= X 150HP
16	0.045.1240.0	1	flange
			=> 10565 X 110HP
			=> 20307 X 130HP
			=> 10174 X 150HP
17	2.1560.006.0	2	gasket 10.2 x 16
18	2.0112.309.2	9	screw m 10 p.1.5 x 25
19	2.1474.010.2	2	washer 10
19	2.1480.015.1	7	washer 10
20	2.1519.009.0/10	1	special oil seal
21	0.046.1256.3	1	flywheel
22	0.047.1242.0	1	crown wheel z=128
23	2.1379.006.0	3	lock-tab 15x15x36,5
24	2.0122.517.7	6	screw m 14 p.1.5x45
25	0.039.1220.3/30	6	engine connecting rod
26	0.039.1250.0	12	screw m 14 p.1.5x63
27	2.1559.114.0/10	6	special bushing
28	2.1599.404.0	1	shoulder ring
29	2.1011.321.2	2	nut m 10 p.1.25
30	0.052.0060.6/30	6	complete piston STANDARD
			- X 150HP
30	0.052.0061.6/30		complete piston + mm 0.50
			- X 150HP
30	0.052.0062.6/30		complete piston + mm 1.0
			- X 150HP
30	0.072.0060.6	6	complete piston STANDARD
			- X 110HP
30	0.072.0061.6		complete piston + mm 0.50
			- X 110HP
30	0.072.0062.6		complete piston + mm 1.0
			- X 110HP
30	0.073.0060.6	6	complete piston STANDARD
			- X 130HP
30	0.073.0061.6		complete piston + mm 0.50
			- X 130HP
30	0.073.0062.6		complete piston + mm 1.0
			- X 130HP
31	0.042.0052.6	6	piston ring set STANDARD

Section: ENGINE
CRANKSHAFT

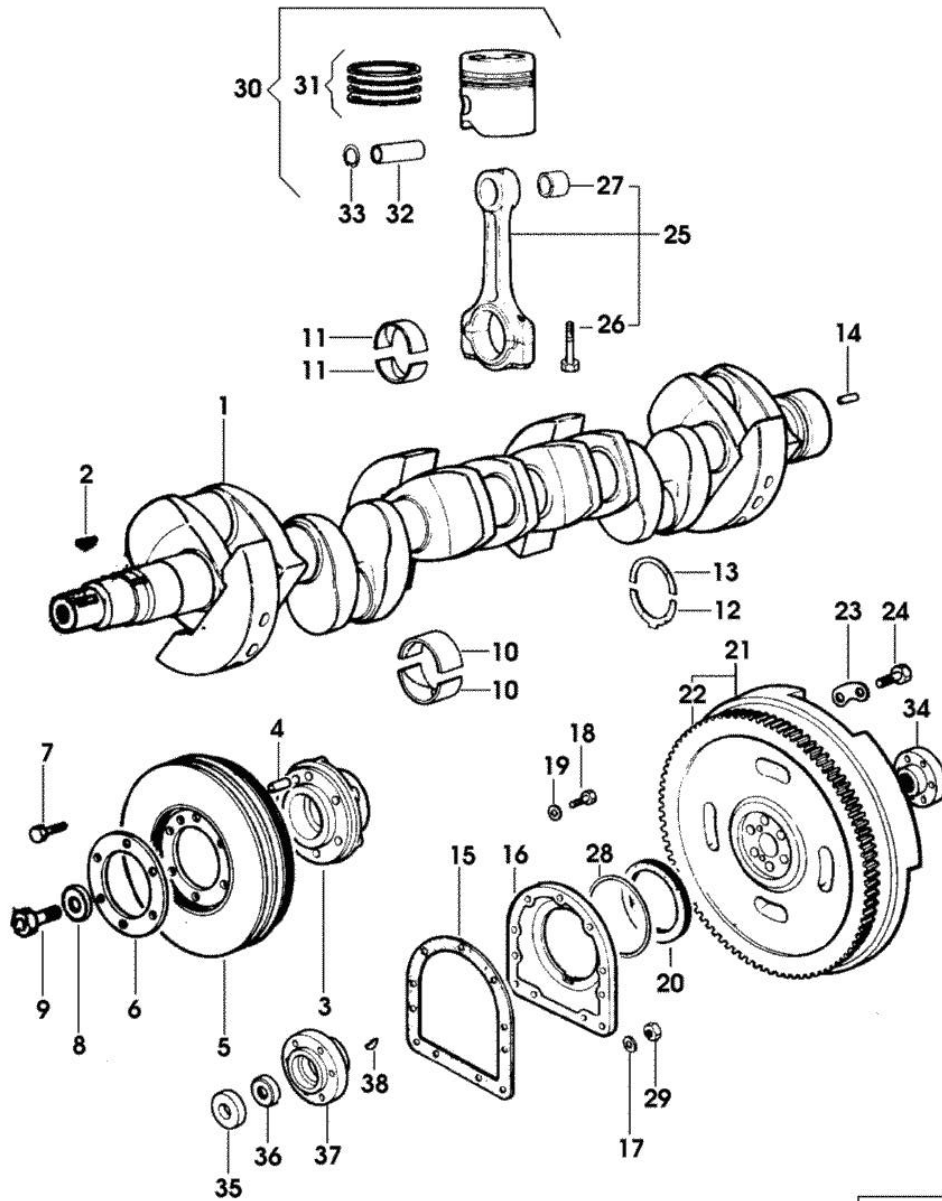

258_006

Fig.	P/n	QTY	Name
31	0.042.0053.6		- X 130HP piston ring set + mm 0.50
31	0.042.0054.6		- X 130HP piston ring set + mm 1.0
31	0.071.0052.6/30	6	- X 130HP piston ring set
31	0.071.0053.6/30		- X 150HP piston ring set + mm 0.50
31	0.071.0054.6/30		- X 150HP piston ring set + mm 1.0
31	0.072.0052.6	6	- X 150HP piston ring set STANDARD
31	0.072.0053.6		- X 110HP piston ring set + mm 0.50
31	0.072.0054.6		- X 110HP piston ring set + mm 1.0
32	0.002.4167.0	6	- X 110HP piston pin
32	0.038.1236.0/10	6	- X 110HP piston pin Ø 18 / Ø 35 / L = mm 90
33	2.1411.014.1	12	- X 130HP circlip 35
34	0.170.3650.0	1	flange
35	0.035.1263.0	1	ring
36	0.035.1262.0	1	- X 130HP spacer
37	0.037.1256.0/10	1	- X 130HP hub
38	2.1799.027.0	1	- X 130HP key

Section: ENGINE

CAMSHAFT

Fig.	P/n	QTY	Name
------	-----	-----	------

Notes:
[LASER 130]

1	0.046.1310.0/10	1	camshaft - EXPORT U.S.A. - X 110HP - X 130HP
1	0.047.1310.0/40	1	camshaft - X 110HP - X 130HP
1	0.071.1310.0	1	camshaft - X 150HP
2	2.3130.001.1	1	plug 1/8" gas
3	0.027.1314.0/10	1	plate
4	2.1470.004.2	2	lock washer 8
5	2.0112.207.2	2	screw m 8 p 1.25 x 20
6	0.062.1321.0	1	gear z=66
7	2.0139.005.1	4	screw m 10 p.1 x 25
8	0.040.1320.0	1	gear z = 33
9	2.1720.010.0	1	key 5x9
10	0.040.1323.0/10	1	gear Z = 38
11	0.052.1330.0/20	12	tappets
12	0.041.1331.3	12	rod - X 110HP - X 130HP
12	0.052.1331.3	12	rod - X 150HP
13	0.041.1332.0	12	sleeve
14	2.1539.020.0	12	special oil seal 13.95x2.62
15	2.1539.022.0	12	special oil seal 12.37x2.62
16	2.4019.162.1/20	12	spring 17.2x46x1.8
17	0.041.1355.3	1	transmission
18	2.1560.014.0	1	washer 18.2 x 24

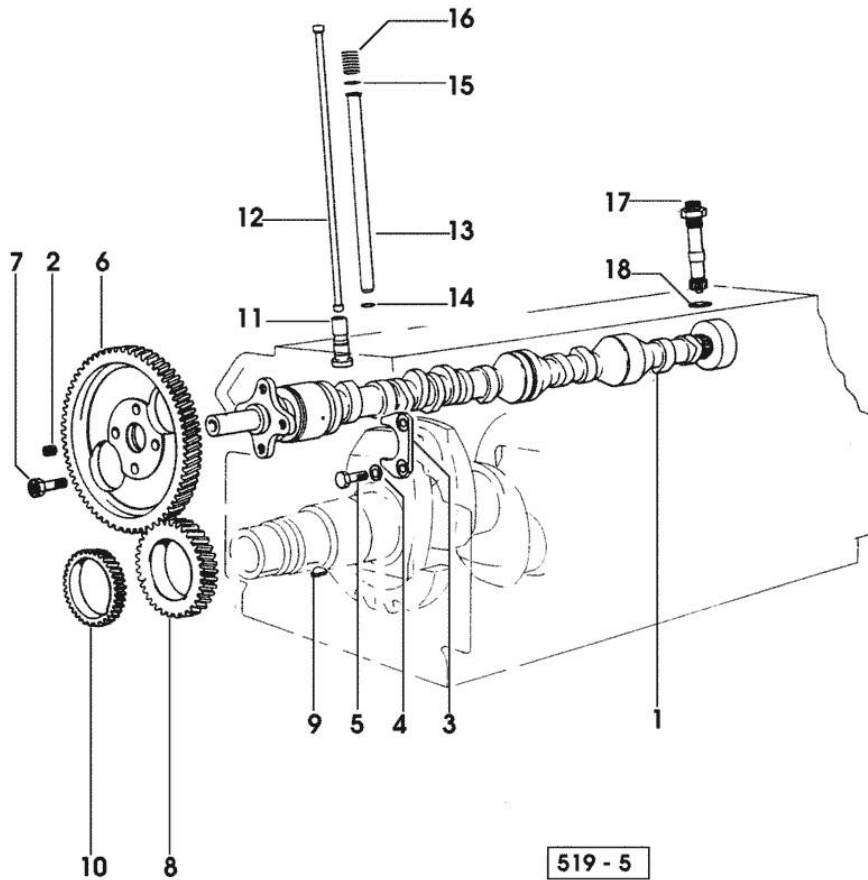

Section: ENGINE
CYLINDER HEAD

Fig.	P/n	QTY	Name
------	-----	-----	------

Notes:
[LASER 130]

1	0.062.1410.3/10	6	engine head - X 130HP
1	0.063.1410.3	6	engine head - X 110HP
2	0.062.1417.0/10	6	valve guide
3	0.062.1416.0/10	6	valve guide
4	0.062.1450.0/10	6	valve seat
5	0.062.1451.0/10	6	valve seat - X 130HP
5	0.063.1426.0	6	valve seat - X 110HP
6	2.0439.087.1/20	12	stud bolt m 8 p.1.25 / p.1 x 40
7	2.1569.077.0/10	6	gasket - X 110HP
7	2.1569.078.0/10	6	gasket 106x118x0.5 - X 130HP
8	2.1019.037.0	3	special nut m 12 p.1.5
9	2.0432.007.2	13	stud bolt m 8 p.1.25 / p.1 x 30
10	2.0432.026.7	6	stud bolt m 8 p.1.25 - 1.00 x 110
11	2.1599.144.7	24	shoulder ring 12.5x23x4
12	2.1019.025.0	21	special nut m 12 p.1.5
13	0.029.1450.0/20	6	tappet gasket
14	0.039.1440.0	6	cap
15	2.1560.004.0	6	copper gasket 8.2 x 14
16	2.1099.056.2	6	special nut m 8 p.1 x 8
17	0.041.1430.0	6	support
18	2.1599.160.0	6	washer 10.5x19x4
19	2.1099.035.0	6	special nut m 10 p.1.25
20	0.029.1452.0	6	tube
21	0.039.1451.0	6	stud bolt
22	2.1011.321.2	6	nut m 10 p.1.25
23	2.1310.006.2	6	flat washer 10.5x21
24	0.002.5937.3/30	6	rocker arm
25	2.1559.021.0/40	6	bushing 15x19x22
26	2.1011.405.2	12	nut m 8 p.1
27	0.021.1434.0	12	screw
28	0.041.1431.0	6	pin
29	2.1599.019.0	6	shoulder ring 19.5x31x2
30	2.1410.055.1	6	circlip 19
31	0.002.5936.3/40	6	rocker arm
32	2.1559.021.0/40	6	bushing 15x19x22

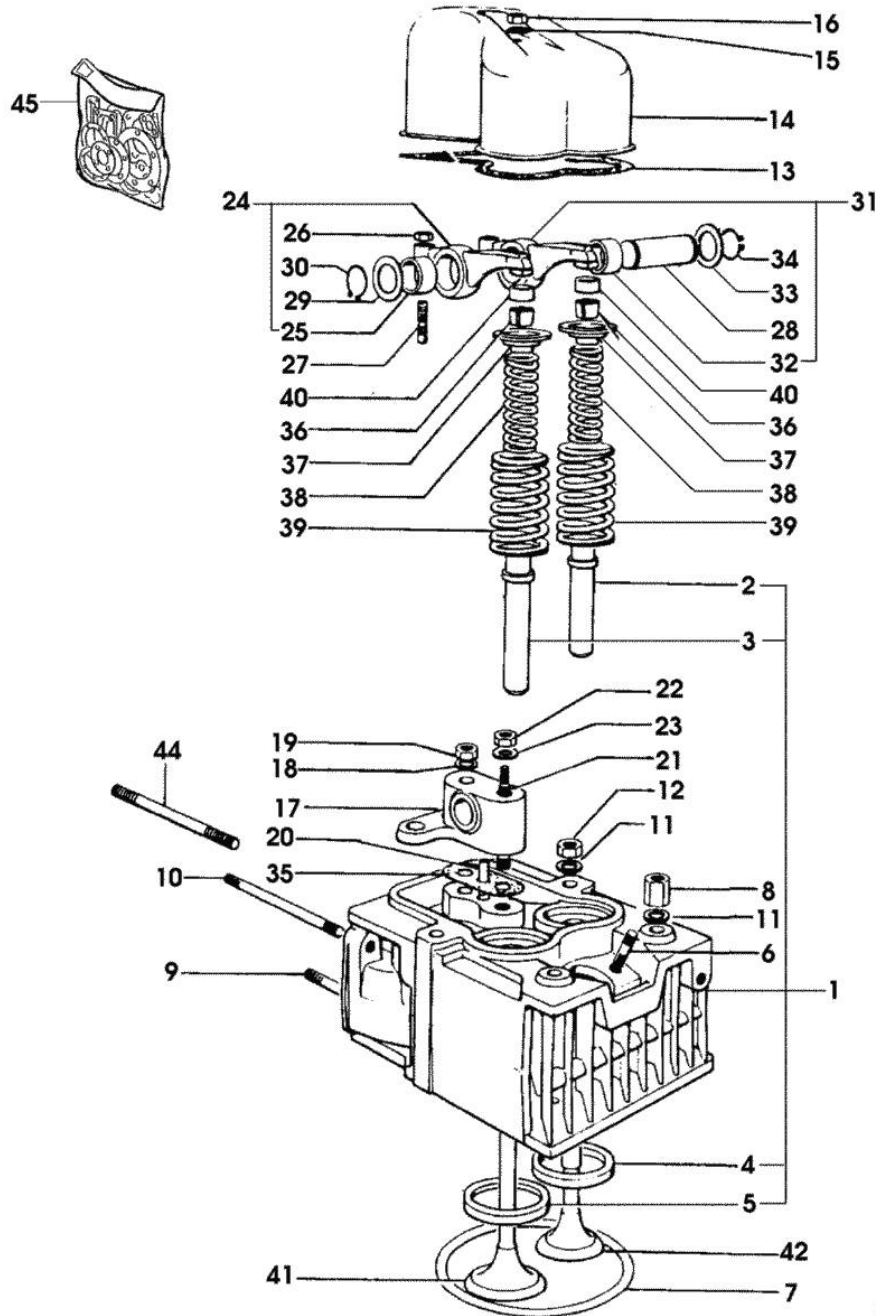

258_009

Section: ENGINE
CYLINDER HEAD

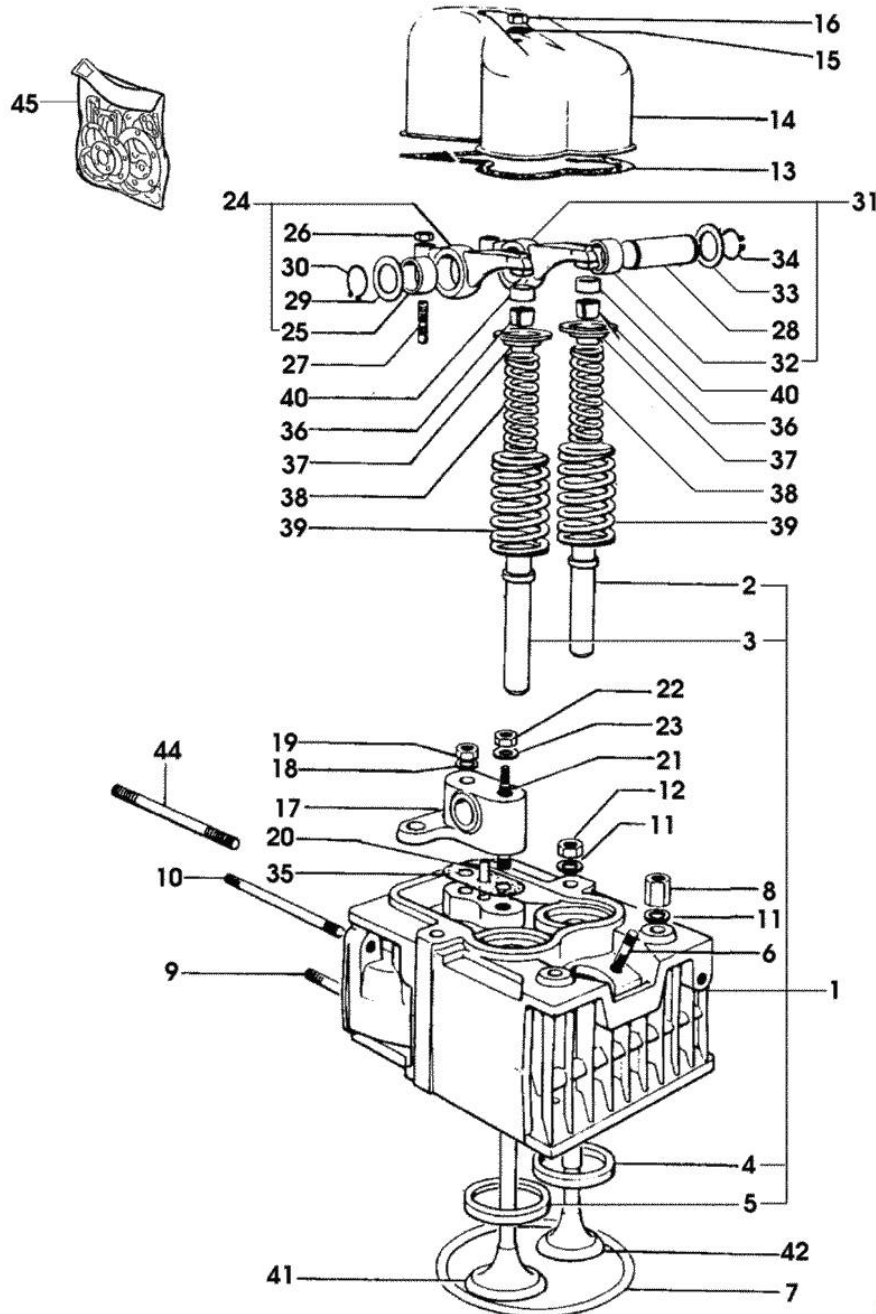

Fig.	P/n	QTY	Name
33	2.1599.019.0	6	shoulder ring 19.5x31x2
34	2.1410.055.1	6	circlip 19
35	0.034.1450.0	6	tappet gasket
36	0.062.1423.0/10	12	conical valve cotter
37	0.062.1425.0	12	cup
38	2.4019.194.0	12	spring 22.70x50.7x2.1
39	2.4019.193.0	12	spring 36.15x55.2x3.2
40	0.062.1452.0	12	small cover
41	0.042.1420.2	6	inlet valve Ø mm 8 - X 130HP
41	0.071.1420.2	6	exhaust valve Ø mm 8 - X 110HP
42	0.071.1420.2	6	exhaust valve Ø mm 8
44	2.0439.143.7	5	stud bolt m 8 p.1.25 x 90 -> 1651 X 130HP
44	2.0439.157.7	5	stud bolt m 8 p.1.25 - 1.00 x 100 -> 1446 - 1650 <- X 130HP
45	0.072.0057.6		gasket set - X 110HP - FOR 1 CYLINDER VALVE GRINDING AND PISTON RINGS REPLACEMEN
45	0.073.0057.6		gasket set - X 130HP - FOR 1 CYLINDER VALVE GRINDING AND PISTON RINGS REPLACEMEN

258_009

Section: ENGINE
LUBRICATION

Fig.	P/n	QTY	Name
------	-----	-----	------

Notes:
[LASER 130]

1	0.047.1510.0	1	oil sump
2	2.1560.054.0	1	gasket 21 x 26
3	2.3199.001.2	1	plug 1/2" gas
4	0.037.1512.0	1	gasket
5	2.0112.244.2	2	screw m 8 p.1.25 x 180
6	2.0112.215.2	30	screw m 8 p.1.25 x 40
7	2.0112.237.2	4	screw m 8 p.1.25x140
8	2.0112.219.2	2	screw m 8 p.1.25x55
9	2.1560.004.0	4	copper gasket 8.2 x 14
10	2.0112.231.2	2	screw m 8 p.1.25 x 110
11	2.0122.213.2	2	screw m 8 p.1x35
12	0.042.1513.2	1	dipstick
13	0.034.1551.0	1	gasket (...) <-
14	0.044.1555.0	1	spacer
15	2.1560.008.0	2	gasket 12.2 x 18
16	2.7099.460.0	1	pressure switch
17	2.3339.094.1/10	1	pipe fitting m 20 p.1.5-3/4 gas
18	0.041.1556.0	1	oil filter element
19	0.052.1530.0	1	tip
20	0.052.1571.0	1	small piston
21	2.4019.270.1	1	spring 9.7x54x2
22	2.1630.213.0	1	roll pin 3x32
23	0.054.1558.0/10	1	stop
24	0.037.1557.0/20	1	gasket
25	2.1480.014.1	2	washer 8
26	2.0112.225.2	1	screw m 8 p.1.25 x 80
27	2.0112.231.2	1	screw m 8 p.1.25 x 110
28	2.7099.270.0	1	device
29	0.046.1531.3	1	tube
30	2.3359.017.1	1	nosepiece
31	2.3359.016.1	1	nosepiece
32	0.044.1560.2	1	tube
33	2.3359.015.1	2	nosepiece
34	2.0112.205.2	1	screw m 8 p.1.25 x 16
35	2.1310.004.2	1	flat washer 8.4x17
36	0.046.1543.2/10	1	tube
37	2.3339.159.1/10	1	pipe fitting
38	0.040.1524.3/50	1	oil pump => 14218 X 110HP => 25099 X 130HP

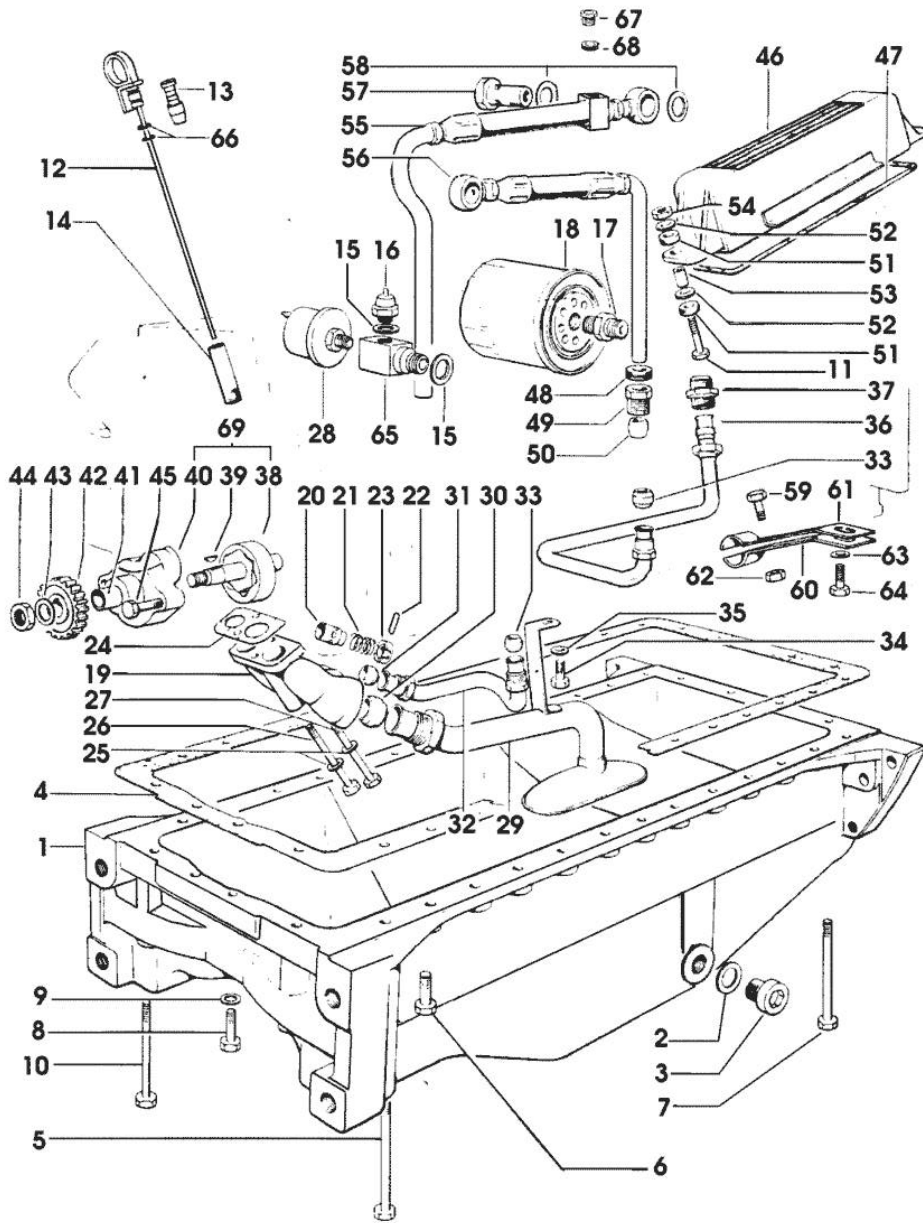

258_012

Section: ENGINE
LUBRICATION

Fig.	P/n	QTY	Name
39	2.1720.005.0	1	key 4x5
40	0.047.1520.3/20	1	pump casing => 14218 X 110HP => 25099 X 130HP
41	2.1559.166.0	1	special bushing
42	0.040.1521.0/10	1	gear z = 27
43	2.1310.007.2	1	flat washer 13 x 24
44	2.1121.109.2	1	self-locking nut m 12 p.1.25
45	2.0112.219.2	2	screw m 8 p.1.25x55
46	0.071.1540.2/10	1	oil cooler - X 130HP
46	0.072.1540.2/10	1	radiator - X 110HP
47	0.047.1552.0	1	gasket - X 110HP
47	0.052.1541.0	1	gasket - X 130HP
48	2.6560.013.0	2	wire guide 18x1.5
49	2.3339.167.2	2	pipe fitting
50	2.3359.012.0	2	nosepiece 10x16.8
51	0.021.1560.0	4	rubber plug
52	2.1599.006.2	4	shoulder ring 8.4x25x2
53	2.1579.159.2	2	spacer 8.8x12x16
54	2.1011.405.2	2	nut m 8 p.1
55	0.007.1770.3/30	1	tube * (...) <- - N.1 2.1560.010.0 - N.1 2.3110.403.1
56	0.047.1551.2/30	1	tube
57	2.3339.107.1	2	pipe union m 22
58	2.1560.018.0	6	gasket 22.2 x 29
59	2.0112.207.2	1	screw m 8 p 1.25 x 20
60	0.046.1551.0	1	bracket
61	0.046.1550.0	1	bracket
62	2.1011.105.2	1	nut m 8 p.1.25
63	2.1310.004.2	1	flat washer 8.4x17
64	2.0112.207.2	1	screw m 8 p 1.25 x 20
65	0.071.1554.0	1	pipe fitting
66	2.1539.065.0	2	special oil seal 8.73 x 1.78 -> (...)
67	2.3110.403.1	1	plug m 14 p.1.5x12
68	2.1560.010.0	1	gasket 14.2 x 20
69	0.040.1524.6	1	oil pump 14217 <= X 110HP 25098 <= X 130HP

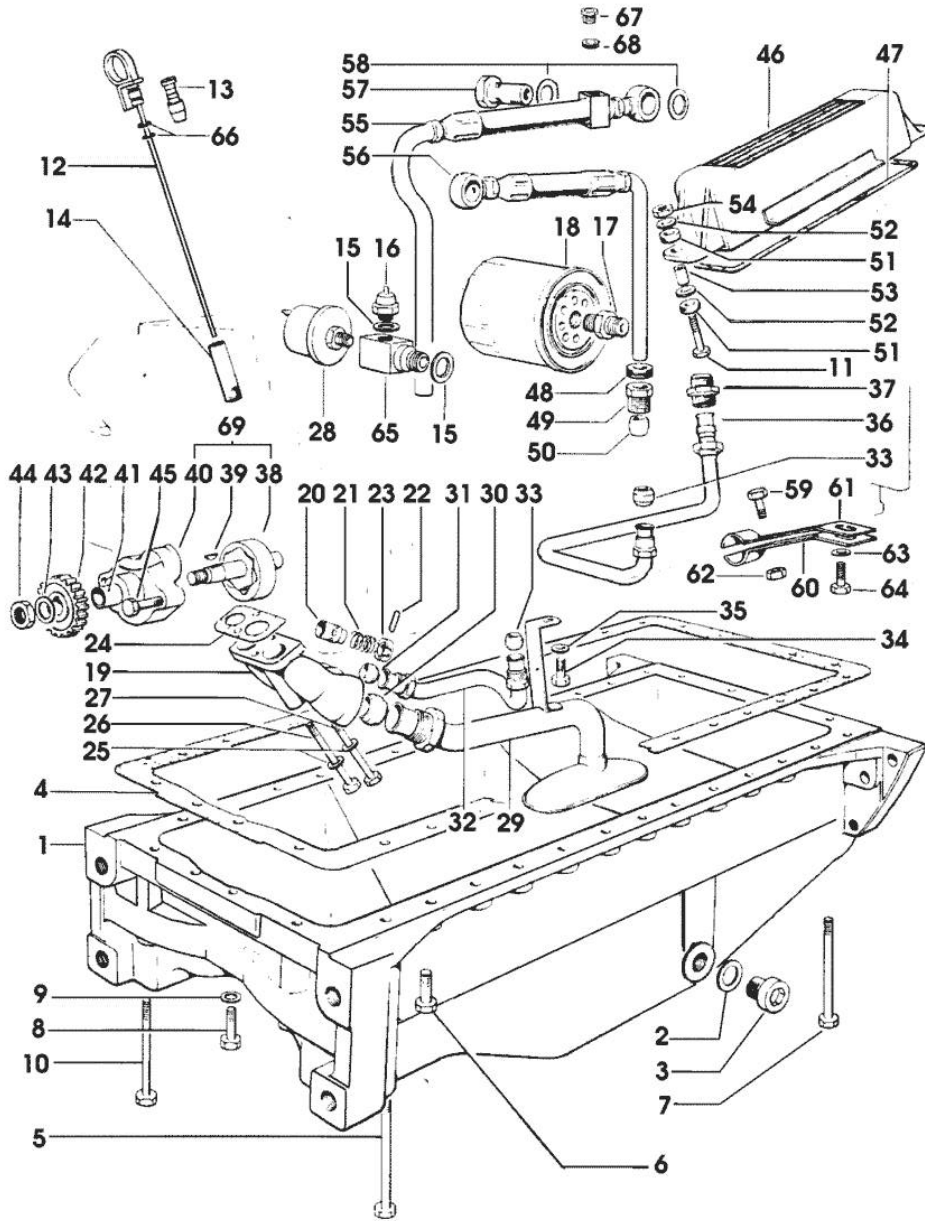

258_012

Section: ENGINE
FUEL SUPPLY SYSTEM

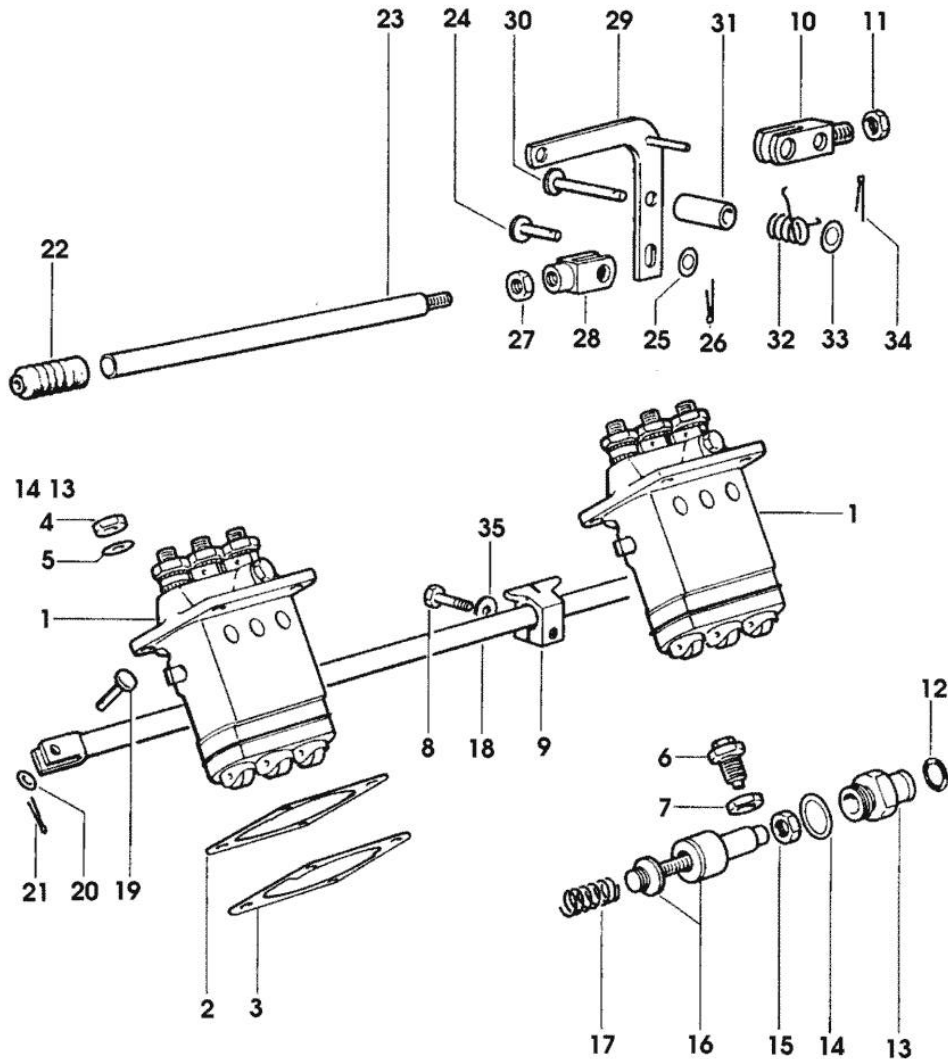

258_017

Fig.	P/n	QTY	Name
Notes: [LASER 130]			
1	2.4639.090.0/10	2	injector pump F 27 ☞ 2.4639.090.0/10 ☞ 01.00.54
2	0.041.1658.0	4	shim mm 0.20
2	0.041.1659.0	2	shim mm 0.1
2	0.044.1672.0	2	shim mm 0.50
3	0.041.1694.0	4	gasket mm 0.1
3	0.041.1695.0	2	gasket mm 0.20
4	2.1099.056.2	8	special nut m 8 p.1 x 8
5	2.1311.006.2	8	flat washer 8
6	0.044.1669.3/20	1	adapter
7	2.1099.066.1	1	special nut
8	2.0112.007.2	1	screw m 6 p.1 x 20
8	2.0112.015.2	1	screw m 6 p.1x40
9	0.074.1653.0	2	bracket
10	0.044.1656.0	1	support
11	2.1011.506.2	1	nut m 10 p.1
12	2.1530.015.0	1	oil seal 8.30x2.40
13	0.041.1666.0/40	1	plug
14	2.1560.019.0	1	copper gasket 24.3x30
15	2.1011.505.2	1	nut m 8 p.1
16	0.041.1678.6/10	1	adapter - X 150HP
16	0.062.1652.6	1	adapter => 20162 X 130HP
17	2.4019.178.1/10	1	spring 14.6x34x0.8
18	0.041.1613.2	1	rod
19	2.1679.065.2	1	pin 6x18x15
20	2.1311.004.2	1	flat washer 6, d128
21	2.1690.206.2	1	split pin A2x15
22	0.000.5617.0	1	guard
23	0.044.1651.0/30	1	ferrule
24	2.1679.065.2	1	pin 6x18x15 - X 130HP - X 150HP
25	2.1310.002.3	1	flat washer 6.4 x 12 x 1.6
26	2.1690.206.2	1	split pin A2x15
27	2.1011.103.2	1	nut m 6 p.1
28	2.3510.003.2	1	fork m 6
29	0.048.1666.2	1	lever



Suggest:

For more complete manuals. Please go to the home page.

<https://www.ebooklibonline.com>

If the above button click is invalid. Please download this document first, and then click the above link to download the complete manual.

Thank you so much for reading

FUEL SUPPLY SYSTEM

Fig.	P/n	QTY	Name
30	2.1670.311.2	1	pin 8x38x35
31	2.1579.159.2	1	spacer 8.8x12x16
32	2.4099.017.7	1	spring
33	2.1310.004.2	1	flat washer 8.4x17
34	2.1690.206.2	1	split pin A2x15
35	2.1579.455.1	1	spacer 6.2x12x14

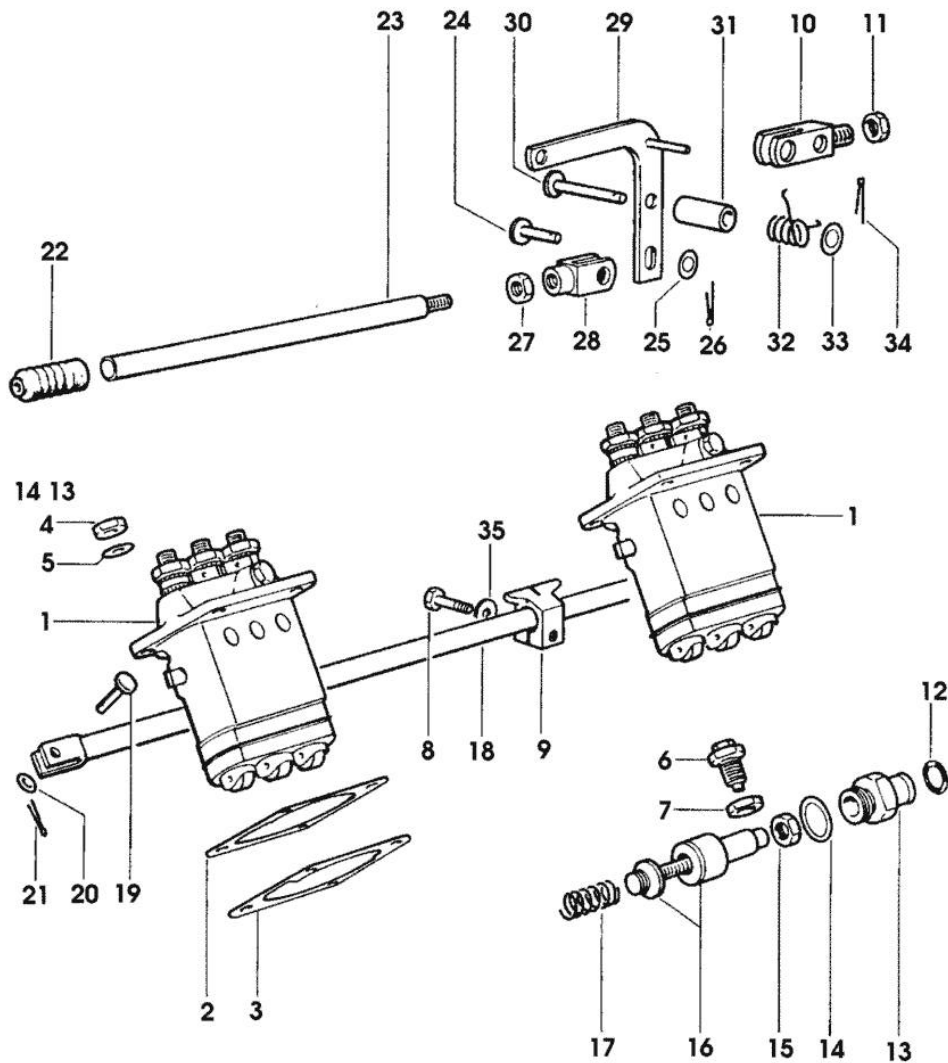

258_017

Section: ENGINE
FUEL SUPPLY SYSTEM

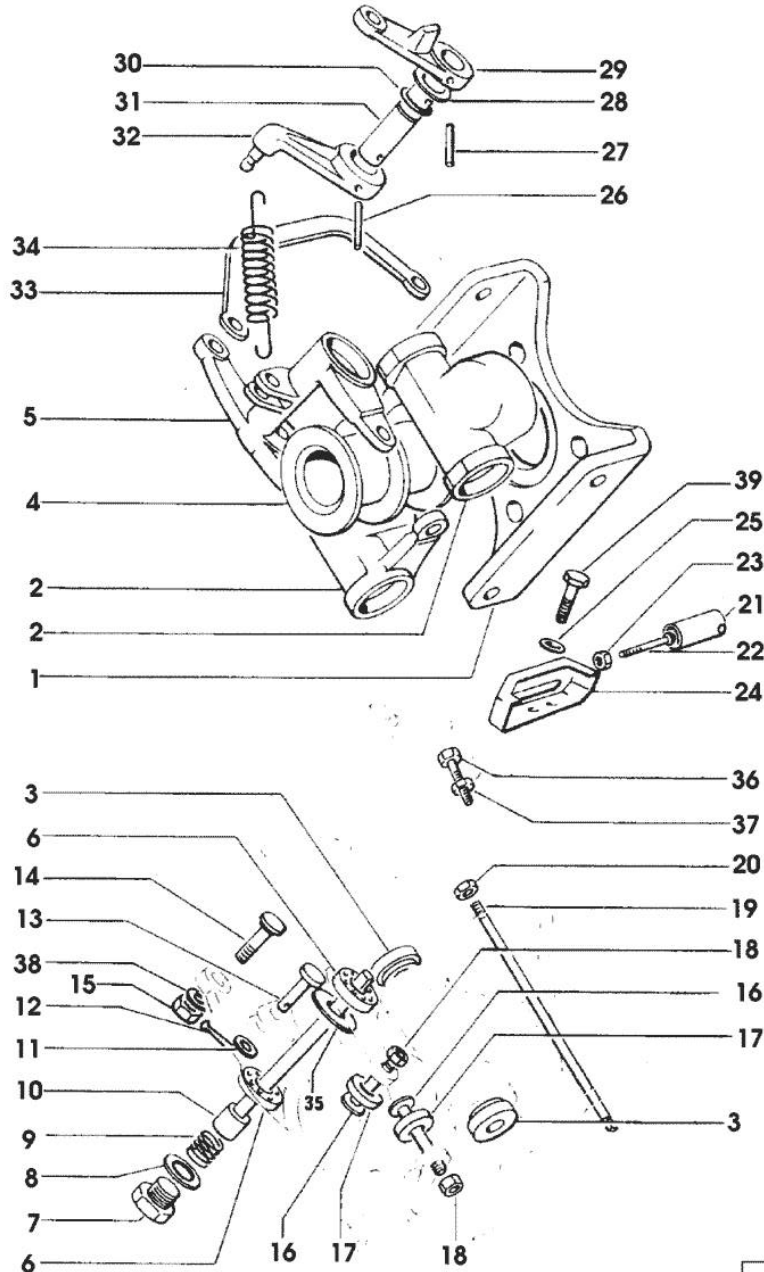

258_018

Fig.	P/n	QTY	Name
Notes:			
[LASER 130]			
1	0.053.1615.0	1	bracket 20161 <= X 130HP
1	0.062.1615.0	1	bracket => 20162 X 130HP - X 150HP
2	0.052.1616.0	2	adjust.rocker 20161 <= X 130HP
2	0.062.1616.0	2	adjust.rocker => 20162 X 130HP - X 150HP
3	0.053.1654.0	4	roller 20161 <= X 130HP
3	0.062.1653.0	2	roller - X 150HP
4	0.071.1618.0	1	sleeve
5	0.042.1619.0/10	1	lever 20161 <= X 130HP
5	0.062.1619.0	1	lever => 20162 X 130HP - X 150HP
6	2.2999.066.0	2	special bearing 7x19x6 20161 <= X 130HP
6	2.2999.158.0	2	special bearing => 20162 X 130HP - X 150HP
7	2.3110.302.1	1	plug m 12 p.1.75 x 10
8	2.1560.008.0	1	gasket 12.2 x 18
9	2.4019.283.1	1	spring
10	0.041.1620.0	1	pin
11	2.1310.001.2	1	flat washer 5.3 x 10
12	2.1690.104.2	1	split pin 1.6x10
13	2.1670.005.2	1	pin 5x22x20
14	0.074.1655.0	1	pin
15	2.1011.103.2	2	nut m 6 p.1
16	0.054.1654.0/10	4	pin
17	0.062.1653.0	4	roller
18	2.1019.007.1	4	special nut m 6 p.1
19	0.053.1617.0	2	pin 20161 <= X 130HP
19	0.062.1617.0/10	2	pin => 20162 X 130HP

<https://www.ebooklibonline.com>

Hello dear friend!

Thank you very much for reading.

Enter the link into your browser.

The full manual is available for immediate download.

<https://www.ebooklibonline.com>